

WIRELESS SENDER C11

TECHNICAL HANDBOOK - TECHNICAL DESCRIPTION

Tels D 122 Part 2 must be read in conjunction
with this Part 1 which contains references to
figures and tables in the Part 2.

SUBJECT INDEX

	<u>Para</u>
SENDER C11	1-40
Introduction	1-4
BRIEF TECHNICAL DESCRIPTION	5-18
Principles of operation	5-6
Power supplies	7-9
Construction	10-17
Controls	18
DETAILED TECHNICAL DESCRIPTION	19-40
R.F. chassis	19-27
Master Oscillator	19-21
R.F. amplifiers	22-23
R.F. power amplifier	24-26
Metering	27
A.F. chassis	28-33
Modulation	28-30
Automatic modulation control	31
C.W. sidetone oscillator	32
Calibrator	33
Systems switch operation	34
Relay operation	35-37
Intercommunication amplifier	38-40
 SUPPLY UNIT, TRANSFORMER, ROTARY, 24V	 41-48
BRIEF TECHNICAL DESCRIPTION	41-42
Construction	41
Controls	42
DETAILED TECHNICAL DESCRIPTION	43-48
Sender supplies	43-45
Voltage control	46-47
Receiver connections	48
 SUPPLY UNIT, RECTIFIER, NO 30	 49-55
BRIEF TECHNICAL DESCRIPTION	49-51
Introduction	49
Construction	50
Controls	51

	<u>Para</u>
DETAILED TECHNICAL DESCRIPTION	52-55
Sender supplies	53
Receiver supplies	54-55
 AERIAL TUNING UNIT NO 7	 56-64
Introduction	56
BRIEF TECHNICAL DESCRIPTION	57-59
Principles of operation	57
Construction	58
Controls	59
DETAILED TECHNICAL DESCRIPTION	60-64
 FILTER UNIT, R.F., NO 15	 65-66

INDEX TO FIGURES

<u>Fig No</u>		<u>Page No</u>
1	Block diagram of sender C11	3
2	Sender front panel controls	7
3	P.A. stage - simplified circuit	9
4	D.C. p.s.u. front panel controls	13
5	A.C. p.s.u. front panel controls	16
6	A.T.U. front panel controls	18

SENDER C11

Introduction

1. The Wireless sender No C11 is designed for use as a ground station or as part of a vehicle installation. The set is an h.f. transmitter giving an output of 50W over a frequency range of 2 - 16Mc/s in three bands. Facilities are provided for a.m., c.w., or, with a separate adaptor carrier frequency shift telegraphy. An intercomm amplifier is incorporated for use when the set is part of a vehicle installation.

2. The set can be used in conjunction with the Receiver R210 using standard Harness type A or B. The h.t. and l.t. for the intercomm amplifier are derived from the receiver power supplies.

3. The set is connected, through Aerial tuning unit No 7, to a rod or wire aerial, or a telescopic mast and directly from the set to a dipole.

4. Details of harness, audio equipment and control boxes are contained in Tels L 772 or L 782.

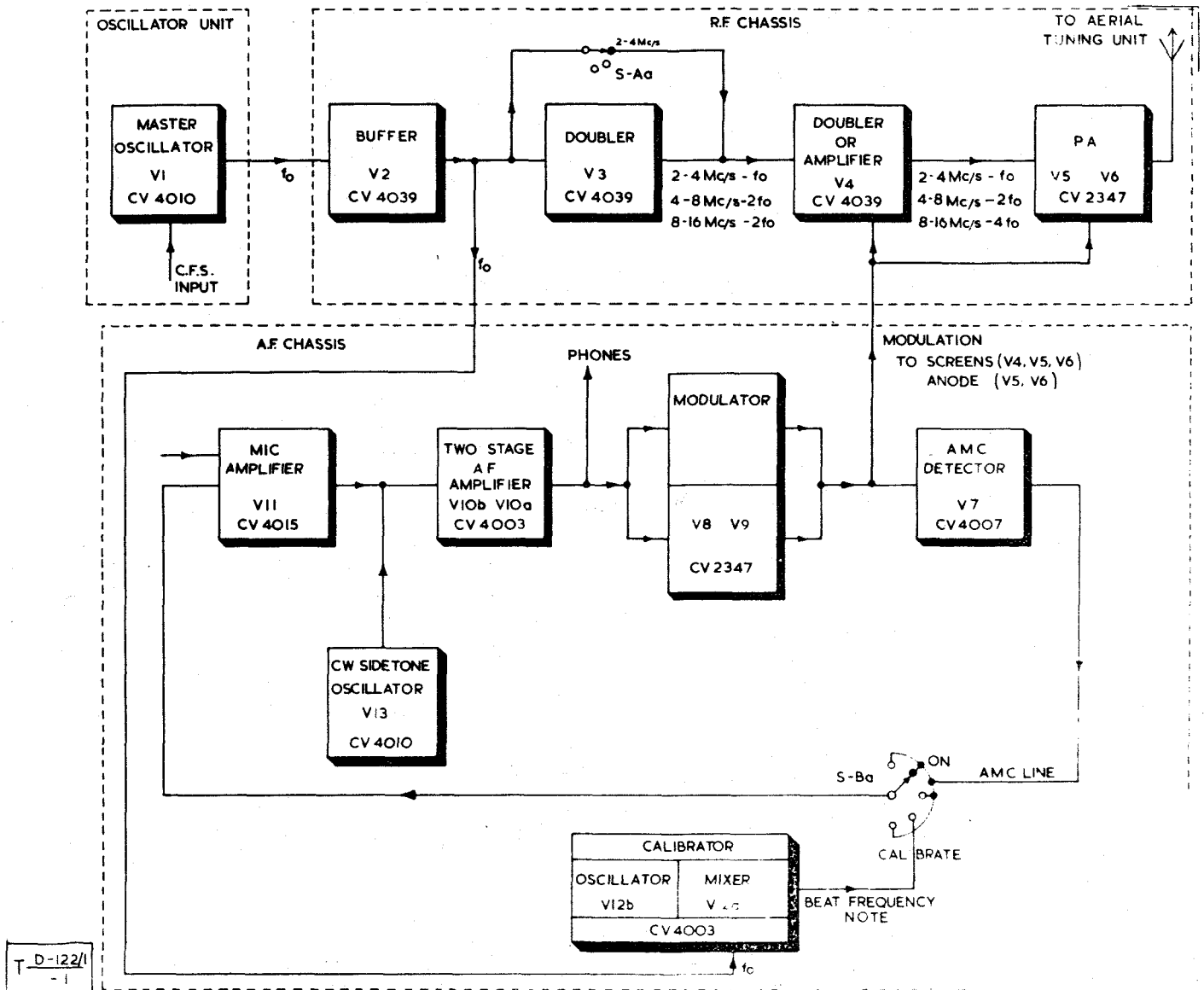

Fig 1 - Block diagram of Sender C11

BRIEF TECHNICAL DESCRIPTION

Principles of operation

5. A block diagram of the sender is shown in Fig 1.
6. The set uses thirteen valves, one germanium diode, and a voltage stabiliser (V14) the line up being: master oscillator (V1), untuned buffer amplifier (V2), a doubler stage (V3) (which is bypassed on the lowest frequency range) an amplifier (V4) (acting as a second doubler on the highest frequency range) and a power

amplifier (V5, V6). The a.f. input is fed to microphone amplifier (V11), through a two stage amplifier (V10b, V10a), to the push-pull modulator stage (V8, V9) the output of which modulates the screen of V4 and the anodes and screens of V5 and V6. Part of the modulator output is fed via a detector (V7) as an automatic modulation control voltage to microphone amplifier (V11). The output of the crystal calibrator (V12b) and a portion of that of the buffer amplifier (V2) are mixed in V12a; the resulting beat note, amplified by V11, V10b and V10a, is fed to the headphones. On c.w. sidetone is provided by an R-C oscillator (V13) which gives a note in the phones via the a.f. amplifier (V10a and b) as a keying aid to the operator.

Power supplies

7. Power for the sender is normally obtained from a Supply unit, transformer, rotary, 24V (d.c. p.s.u.). Input for this unit is nominally 24V at 20A and outputs are:-

- (a) +530V d.c. at 450mA. The negative of this supply is returned to earth via resistors in the sender across which bias voltages are developed. A stabilised supply of +300V to earth is derived from the +530V supply.
- (b) +19V d.c. at 3A as heater supply.
- (c) +24V d.c. as relay voltage supply.

8. Supplies for the intercomm amplifier are provided by the Receiver R210 power pack but are coupled to the sender via the d.c. p.s.u. For a detailed description see paras 41 to 48.

9. When the Sender C11/Receiver R210 combination is used where a mains supply is available power may be obtained from the Supply unit, rectifier, No 30 (a.c. p.s.u.). This unit is designed to operate from 100-120V and 200-240V a.c. and supplies (in addition to the sender voltages listed in para 7) +175V d.c., 6.3V a.c. and -30V d.c. for the Receiver R210 and the intercomm amplifier. For a detailed description see paras 49 to 55.

Construction

10. The sender is secured in a steel case by four knurled screws, captive to the case rear panel. Two collapsible carrying handles are fitted to the sides of the case.

11. Ventilation is provided by a blower motor which operates through two filtered air intakes on the front panel and an outlet on the rear of the case. Flaps are provided for the intakes and a screwed cover for the outlet to make the equipment waterproof.

12. The sender is constructed in four main units:-

- (a) The front panel and oscillator assembly
- (b) The r.f. chassis
- (c) The modulator or a.f. chassis
- (d) The ventilator or blower assembly

13. The front panel, of cast alloy, has a raised fence to protect plugs etc should the set be stood face downwards. All knobs are of heavy duty type. The oscillator assembly and the condenser gearing are mounted behind the front panel.

14. The oscillator circuits are fitted in a sealed box to increase frequency stability and fitted with a desiccator. Access to the adjustable circuits is allowed when the desiccator and seal testing plugs are unscrewed, and the top and bottom of the box are removable for servicing, since the complete unit cannot be easily disconnected from the gearing. The oscillator capacitor is driven through spragged gears and tuning indication consists of two circular plates, each engraved with three concentric scales, rotating angularly with the linear-law capacitor past the cursor on the front panel window. On each frequency range two scales are used; one (Mc/s) indicates to the nearest 100kc/s points and the other (Kc/s) is so geared that frequencies can be set to 2.5kc/s points, eg for a frequency of 2.1725Mc/s the Mc/s dial is set to 2.1 and the Kc/s dial to 72.5. The unwanted scales are blanked by a shutter operated by the range switch.

15. The ganged capacitors in the r.f. chassis are driven through further antibacklash gearing. This chassis is mounted to the right of the oscillator assembly, viewed from the rear, and is hinged on the outer edge of the front panel. When the chassis is swung outwards the drive gear connection, consisting of a spring-loaded two-pronged coupler, and the range switch coupler, consisting of a forked plate and pin, are disconnected. All connections to the chassis are made to a coded soldered tag panel, easily accessible on the top of the chassis, except for the modulation voltage to the p.a. which is fed via two leads plugged into the ventilator sub chassis.

16. The a.f. chassis, mounted on the opposite side of the oscillator assembly, hinges in a similar manner to the r.f. chassis. The method of connection is also identical and the systems switch is coupled to the front panel in the same manner as the range switch.

17. The ventilator sub chassis normally hinges with the a.f. chassis but can be unscrewed for servicing. It is connected to the a.f. chassis by a cableform of sufficient length to allow this. In addition to the blower motor this chassis contains the modulation transformer.

Controls

18. The controls on the front panels consist of the following:-

SA	Range selector	Selects one of the three frequency bands.
SB	Systems switch	
	C.W.	Rotary transformer is held on by SB and p.a. bias controlled by key. A sidetone oscillator is brought into circuit as an operator's keying aid.
	VOICE/CFS	Rotary transformer and p.a. bias are controlled by pressel for R/T use. Frequency shift keying can be used with an additional adaptor unit.
	SENDER ON	The sender is held on send by SB.

INT. CAL.	The crystal calibrator is in circuit and the m.o. frequency can be adjusted.
ADJ. TO REC.	The sender frequency can be compared with that of its associated receiver.
SC POWER LOW-HIGH	
HIGH	Sender delivers full output.
LOW	Sender output reduced to about one tenth of normal output.
SD Meter switch	
LT.X5	Indicates relay supply voltages (battery volts when using d.c. p.s.u.).
HT.X100	Indicates +530V h.t. voltage.
GRID P.A. X1	Indicates r.f. drive.
CATH. P.A. X30	Indicates p.a. cathode current.
Tuning control	Varies the master oscillator and power amplifier capacitors.
L2 CALIBRATE	Alters part of master oscillator inductance to allow alignment at crystal calibrator check points.
SE LOCK	Locks the tuning drive and switches off the dial light in locked position.
PLA	Connects supply voltages to the sender from the p.s.u. (12-way Mk 4B plug).
SKTB	Carries connections to Wireless Control Harness A or B (12-way Mk 4B socket).
PLC AERIAL	Connects the aerial or A.T.U. No 7 (Burndept pattern 4 coaxial plug).
SKTD REC. AE.	Used (with PIC) to interconnect the aerial to the associated receiver (Belling Lee bayonet coaxial socket).
SKTG C.F.S.	Connects the d.c. voltage on c.f.s. telegraphy (Belling Lee bayonet coaxial socket).

DETAILED TECHNICAL DESCRIPTIONR.F. Chassis
(Fig 2002)Master oscillator

19. The master oscillator is designed to be very stable and to have a high setting and resetting accuracy. These qualities are achieved by:-

- (a) operating over a restricted frequency range (2-4 Mc/s); ie no range switching of the m.o.
- (b) using a precision tuning capacitor (C3) temperature compensated by a bimetal vane and driven through antibacklash gearing.
- (c) further minimising frequency drift due to inductance variations with changes of temperature by the use of negative temperature coefficient capacitors (C5 and C7).
- (d) stabilising the oscillator h.t. supply by V14.
- (e) fitting all the m.o. circuitry in a hermetically sealed unit.

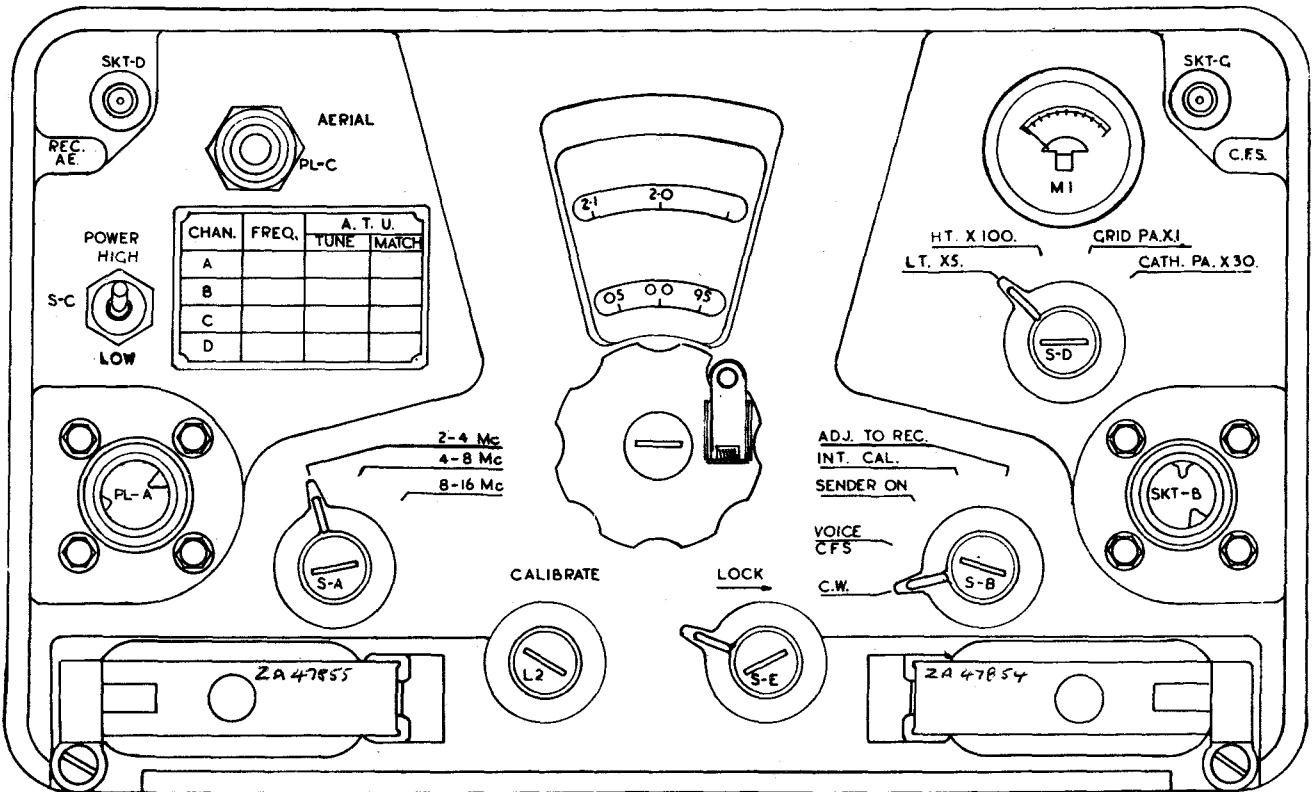

D122-1
1-2

Fig 2 - Sender front panel controls

20. The circuit employed is an inverted Colpitts type, the tap formed by C8 and C10 across the tuned circuit being connected to V1 cathode. L3 provides a c.d. return for the cathode to earth. A small inductor L2 (in series with the main tuning inductor L1) has a dust core variable from the front panel (CALIBRATE) so that the m.o. frequency can be adjusted to the crystal calibrator or to the associated receiver.

21. A ferrite reactor (X1) provides oscillator frequency-shift for c.f.s. telegraphy. The primary or d.c. winding of X1 is supplied from the 80-0-80 d.c. keying supply via SKTG. Changes in current through this d.c. winding alter the permeability of the ferroxcube core and thus the inductance of the secondary or r.f. winding which is on the core. This winding is in series with m.o. inductors L1 and L2 and so the m.o. frequency is varied. The amount of frequency shift can be adjusted by RV1 which, in series with R3, is connected across the d.c. input developed across R91. R2 and R7 are switched to form a potential divider with R91 on the two higher frequency ranges. Less m.o. shift is required on these ranges because the m.o. frequency, and hence the shift, is doubled or quadrupled by the r.f. stages which follow. A standing current to set the mean operating point of X1 is obtained through R1a and R1b from the h.t. supply.

R.F. amplifiers (V2, V3 and V4)

22. The output from the m.o. is taken via C9 to the grid of V2, an untuned buffer amplifier. The output from the anode load of this stage (L4 and R12) is taken via C12 to the grid of amplifier V4 on the 2-4Mc/s range and to grid of doubler stage V3 on the two other ranges. V3 has a parallel-fed tuned anode load consisting of L6 and C18 (driven via gearing from oscillator capacitor C3) and trimmed by a tuning slug on L6 and variable capacitor C19. The output of the doubler stage is fed via C23 to V4, which is an amplifier on the bottom two ranges and a doubler on the highest range. The action of V3 and V4 is shown below; it must be remembered that V3 input is always between 2 and 4Mc/s.

Range	V3	V4
2-4Mc/s	Out of circuit	Amplifier
4-8Mc/s	Doubler	Amplifier
8-16Mc/s	Doubler	Doubler

23. V3 anode and screen voltages and V4 anode voltage are taken from the +530V line via R19 but V4 screen voltage is fed via SC and modulation transformer T1 on HIGH power and via R29 and T1 on LOW power. Bias for V3 and V4 is obtained by cathode resistors R18 and R24 but valves are cut off on stand-by due to the grids being returned to junction of R63 and R64 (Fig 2003). A voltage of about -100V will be developed across R63 with RLD1 open due to the currents flowing to the 530V -ve line. The tuning capacitor C32 for V4 stage is ganged to C18 and the inductors L8, L9, L10, with their respective trimmers (C28, C29, C30), are switched across C32 by SAb which simultaneously shorts the two unused inductors to earth.

R.F. power amplifier (V5, V6)

24. The output from V4 is fed via C46 to the r.f. power amplifier which consists of two valves (V5 and V6) in parallel. The anode and screen volts are obtained from the +530V line through the secondary of modulation transformer T1 so modulating the stage. On LOW power R30 is shunted across T1 and R29 is switched in series with the screen voltage to V4, V5 and V6. A simplified diagram is shown in Fig 3. L11, R32, L18, R33 are inserted to prevent parasitic oscillation of the stage.

25. The anode tuned circuits consist of C79, a variable capacitor flexibly coupled to C18 and C32, and the switched inductors and trimmer capacitors L12, C49, L13, C50, L14 and C51. The coils are tapped to give a 70Ω output through R1B1 to the aerial plug on send, while on stand-by the aerial is connected, through R1B1 R1B2 and SKTD, to the associated receiver input. L19 is an r.f. choke and R34 drops the 24V relay supply used to light the dial lamp on the aerial tuning unit. C22 feeds a small voltage at the m.o. frequency to the receiver via SKTD to check sender frequency on ADJ. TO REC., while C82 feeds a similar voltage to the calibrator mixer (V12a) for use on INT. CAL.

26. The p.a. stage is cut off on stand-by since the grids are taken to the same point as the grids of V3 and V4 (see para 23). Bias, when operating, is developed partly by the auto bias effect of C46 and R25, since grid current flows, and partly by common cathode resistor R31.

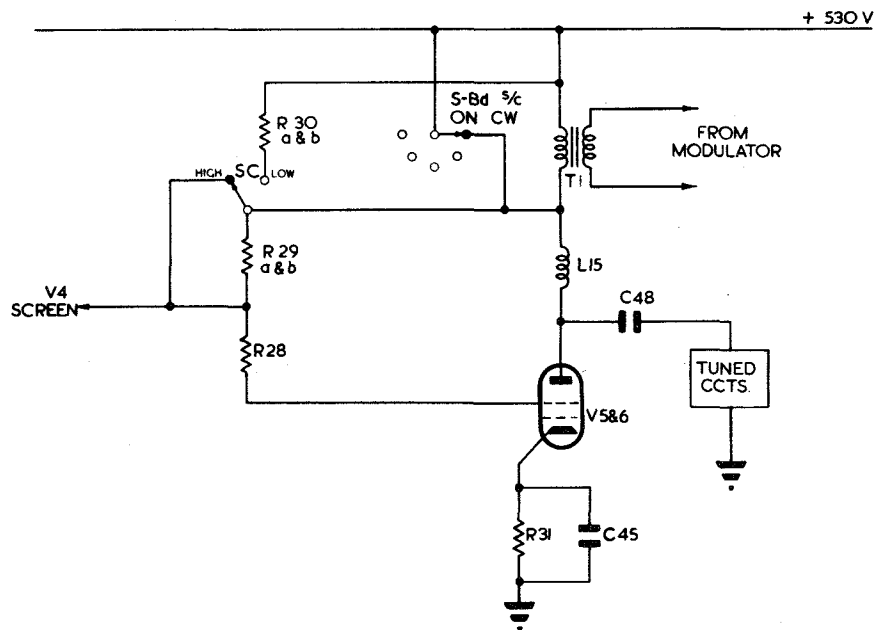

T D122-1
1-3

Fig 3 - P.A. stage - simplified circuit

Metering

27. M1 is a 500 μ A meter calibrated 0-5-10. R80, R61a and b, and R62 are multipliers for 24V, 530V and V5 and V6 cathode volts respectively, and are chosen to give approximately half scale deflection in each case. R27 is shunted across the meter to measure the grid current of V5 and V6 thus indicating r.f. drive.

A.F. chassis
(Fig 2003)

Modulator

28. The microphone input is taken via SKTB from the harness to transformer T3 and amplified by V11, V10b and V10a. The output from V10a is fed to the modulator stage, (V8 and V9 connected in push-pull) via transformer T2. A third winding on T2 feeds sidetone to the headphones via RLC2 (closed on send). Negative current feedback is applied on all three stages by the un-decoupled cathode resistors and negative voltage feedback is applied from anode to grid of V10a via R44 and C58.

29. The modulator (V8 and V9) anode voltage is taken from the +530V line through SBd in the VOICE/CFS and SENDER ON positions while the screens are supplied from the +300V stabilised supply via SBC. To compensate for the extra drain on the stabilised supply with the modulator on, R35 is connected in parallel with R40 between the +530V and +300V lines. Bias for the modulator is obtained from the voltage developed across R65 on high power, and R65 and R64 on low power, by the h.t. current flowing to the 530V negative line (PLAB) since R63 is shorted to earth on send.

30. The modulation transformer (T1) is situated on the blower sub-assembly and the output to the p.a. is taken from two sockets (SKTE and SKTF). The modulation is described in para 24 and Fig 3. R30 is connected across T1 secondary on low power to maintain correct impedance matching.

Automatic modulation control

31. Automatic modulation control (a.m.c.) is obtained by taking a portion of the a.f. signal from a third winding on T1, rectifying it, and feeding the negative voltage to the grid of the microphone amplifier (V11). R38a, R38b, R36 and RV2 form a chain between the +530V line and earth and the cathode voltage of a.m.c. detector (V7) is adjusted by RV2 to delay the a.m.c. voltage until the modulation depth is more than 70%. R37 and C56 determine the discharge time of the a.m.c. line so that the voltage does not follow the modulation while R56 and C63 prevent short surges being fed to V11 grid. The delay voltage is reduced on low power by switching (SC) R59 across R36 and RV2.

C.W. sidetone oscillator

32. V13 is a resistance-capacity oscillator whose output, at about 1kc/s, is coupled by C59 to V10b. V10b is cut off on C.W. with the key up since R66 and R48 form a potential divider for the -100V developed across R63. This bias is removed when the key is closed; the input to V10b will, therefore, be a keyed 1kc/s note which, amplified by V10b and V10a, is coupled to the phones via T2.

Calibrator

33. V12b is a 100kc/s crystal-controlled oscillator operating as a Colpitts type circuit. The feedback tap across the crystal (formed by C68, C36 and C69, C70) is connected to V12b cathode which is returned to earth via r.f. choke L16. The anode transformer T4 has a low primary inductance and a germanium diode is connected across its secondary. This ensures that the input to V12a is peaky and so is rich in 100kc/s harmonics extending throughout the h.f. band. The m.o. output is coupled from V2 anode via C82 to V12a anode where it is mixed with the crystal oscillator harmonics giving an audio beat note at 100kc/s intervals. This output is developed across R77 (higher frequency products of the mixer being filtered by C65) and fed via C66 to V11 grid, amplified and coupled to the phones by T2.

Systems switch operation

(Figs 2003, 2005 and 2006)

34. Fig 2006 shows the disposition and wiring of the system switch wafers. The action of the four banks of SB are:-

(a) SBa

- (i) Earths the send/receive line (SKTB-D) in SENDER ON, INT. CAL. and ADJ. TO REC. positions so that RLE (and RLD in SENDER ON) are permanently energised (see Fig 2005, location C7)
- (ii) Short-circuits junction of R46 and R48 to earth on all positions except C.W. where sidetone keying bias is required (see Fig 2003, location S6)
- (iii) Connects the a.m.c. line to microphone amplifier (V11) on all positions except INT. CAL. when the output of calibrator mixer (V12a) is connected to V11 (see Fig 2003, location AA5)

(b) SBb

- (i) Disconnects RID coil from send/receive line (SKTB-D) on INT. CAL. and ADJ. TO REC. since bias must not be removed from p.a. on these positions though RLE must be energised (see Fig 2005, location B7)
- (ii) Holds rotary transformer starting relay (RLH) in by earthing PLA-L on C.W., INT. CAL. and ADJ. TO REC (see Fig 2005, location C8)
- (iii) Holds aerial changeover relay (RLB) in on INT. CAL. and ADJ. TO REC (see Fig 2005, location E7)

- (c) SBc Connects the 300V stabilised supply to the sidetone oscillator (V13) on C.W., to the modulator (V8 and V9) on VOICE/CFS and SENDER ON, and to the calibrator (V12) on INT. CAL (see Fig 2003, location X7)

(d) SBd

- (i) Connects the receiver output to the phones on ADJ. TO REC. since RIC2 is closed on this position (see Fig 2003, location BB3)
- (ii) Short-circuits the modulation transformer (T1) secondary on C.W. to slightly increase power output and to prevent voltage pulses appearing at the p.a. (V5 and V6) anodes during keying. On VOICE/CFS and

SENDER ON connects R35 in parallel with R40 (between +530V and +300V lines) to compensate for extra current drain from the 300V supply when the modulator is on (see Fig 2003, location R1)

Relay operation
(Figs 2003 and 2005)

35. RLD and RLE are high-speed keying relays which are energised when the send/receive line (SKTB-D) is earthed by the key on C.W., the pressel on VOICE/CFS or the system switch SBa on SENDER ON. RLE1 energises RLC/4 and RLD1 short-circuits bias resistor R63.

36. Relay RLC/4 is held in by R60 and C54 during c.w. keying but will open between sentences so allowing break in operation. The action of the contacts of RLC/4 are as follows:-

- (a) RLC1: Removes the short-circuit from the m.o. (V1) screen and completes the circuit for keying relay RLD. This ensures that the bias will not be removed from the p.a. until there is drive from the m.o.
- (b) RLC2: Changes the headphones over from the receiver output to sidetone output.
- (c) RLC3: Energises the aerial changeover relay RLB/2 and, on VOICE/CFS and SENDER ON, the rotary transformer starting relay (RLH in the d.c. p.s.u.) via PLA-L and SBb.
- (d) RLC4: Short-circuits R90 so that the cooler fan motor operates from the full 24V supply.

37. RLB/2 is a heavy duty relay which, on standby or receive conditions, connects the aerial to the associated receiver via PLC, C53 and SKTD. On send, RLB1 connects the aerial to the sender and RLB2 short-circuits the receiver socket SKTD to earth via C53.

Intercommunication amplifier (Fig 2007)

38. The intercomm unit is shown as a separate unit since, though it is physically part of the a.f. chassis, it is electrically independent of the sender circuits. H.T. and l.t. supplies for the unit are derived from the associated receiver power supplies via the harness and the sender d.c. p.s.u. If, however, the sender a.c. p.s.u. is used, it will supply sender, receiver and intercomm amplifier.

39. The intercomm microphone input is taken from the harness via SKTB to the primary of T5. The secondary of T5 is connected through a low pass filter C38, R75 and C39, to the grid of V15. The signal, amplified by V15 and V16, is transformer-fed by T6 to the phones. V15 and V16 have negative current feedback and negative voltage feedback is applied to V16 via R87 and C33. This keeps the output impedance low so that paralleling a number of phones across T6 has a negligible effect on the output.

40. The windings of T5 and T6 are so connected that, if SKTB-J is coupled to SKTB-C positive feedback causes l.f. oscillation. This is utilised as a call signal when connected in a vehicle installation using Harness type A.

SUPPLY UNIT, TRANSFORMER, ROTARY, 24V

BRIEF TECHNICAL DESCRIPTION

Construction

41. The Supply unit, transformer, rotary, 24V (d.c. p.s.u.) is housed in a case of similar construction to, but narrower than that of the sender. A carrying handle is fitted on the top of the case. The unit is cooled by a blower fan on the rotary transformer shaft which draws air through a filtered intake on the front panel and expels it through an aperture at the back of the case. Both inlet and outlet can be closed to waterproof the p.s.u. A strong tubular frame bolted to the front panel has a central tray chassis. The rotary transformer and stabiliser valves are mounted on this chassis while the smaller components are mounted under it.

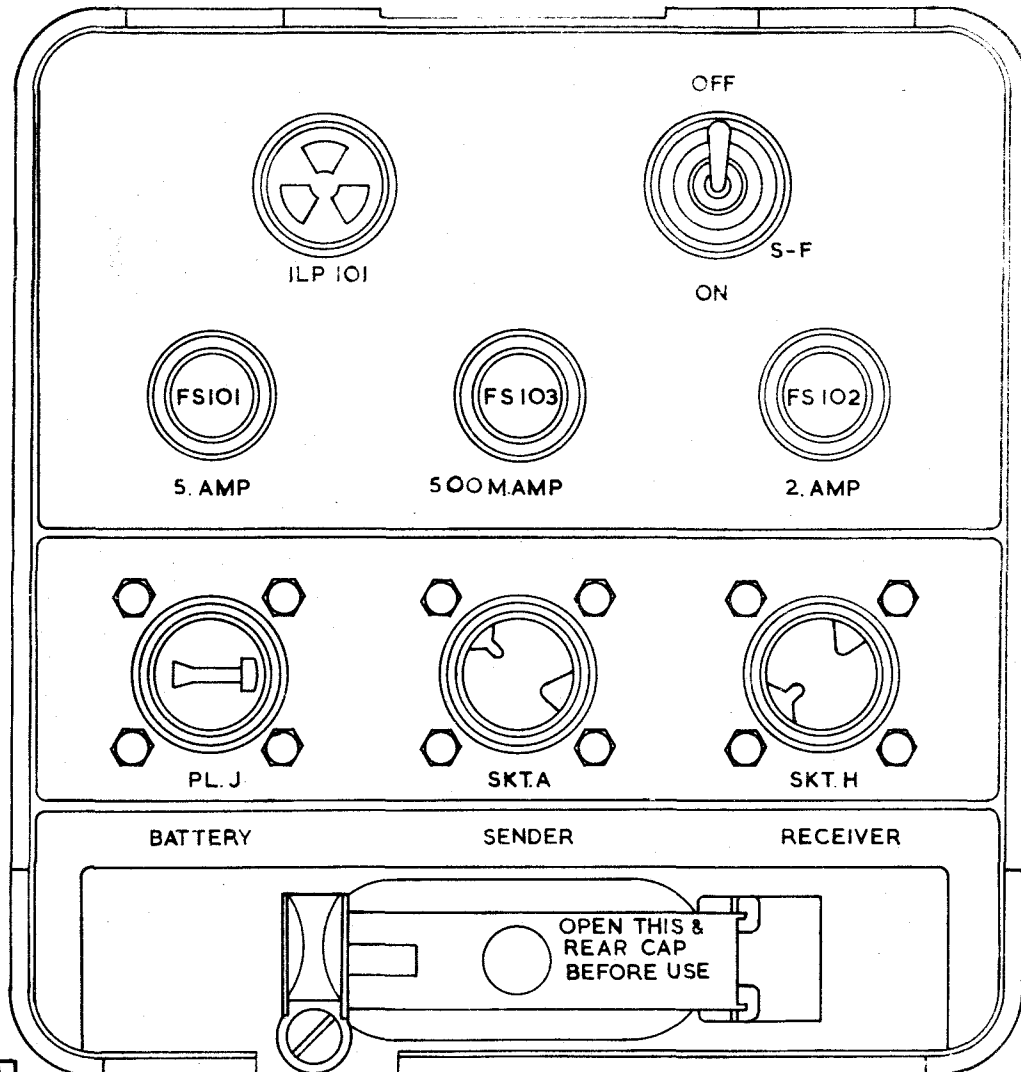

T D122-1
1-4

Fig 4 - D.C. p.s.u. front panel controls

Controls

42. The controls on the front panel consist of:-

SF	OFF-ON	A toggle switch used to connect the battery volts to the sender heaters and control relays.
PLJ	BATTERY	A 4-way Mk 4B plug used to connect the 24V to the p.s.u.
ILP101		An indicating lamp which lights when 24V is applied through FS101.
SKTA	SENDER	A 12-way Mk 4B socket (orientation 1) used to feed out h.t., l.t. and relay supplies for the sender and h.t. and l.t. for the intercomm amplifier.
SKTH	RECEIVER	A 12-way Mk 4B socket (orientation 2) used to connect 24V d.c. and two voltage control connections to the p.s.u. of the associated receiver. The intercomm supplies and receiver phones are linked to the sender via SKTA.

DETAILED TECHNICAL DESCRIPTION

(Fig. 2015)

Sender supplies

43. When SF is closed +24V is applied from PLJ, through FS101, to the indicator lamp ILP101 relays RLF, RLG and RLH and, via SKTA-K, to the relays in the sender C11. Heater voltages are supplied to the sender via R102, R106 and SKTA-M.

44. RLH is energised when the send/receive line SKTA-L is earthed and +24V is fed through RLH1 to the rotary transformer X1 via R103 or RLG1 (para. 46). The positive output of X1 is taken through FS103 and r.f. choke L102 to SKTA-A and the negative line through choke L103 to SKTA-B giving 530V d.c. between these pins. A stabilised 300V d.c. supply is available between pins C and D and earth when the sender is connected. R104 and R105 provide the priming voltage for the stabilisers V101 and V102 but the dropping resistor to V101 from the +530V d.c. is situated in the sender (R40 Fig. 2003). This prevents a heavy current through the neon stabilisers when the sender is disconnected.

45. C106 smooths the rotary transformer output and r.f. suppression is achieved by fitting ferrite beads (FB) on the input leads to X1 primary and by capacitors C101-C104 and C109-C114. Further ferrite beads and capacitors C105, C107 and C108 at the input plug PLJ complete the suppression circuits.

Voltage control

46. The input voltage to the p.s.u. may vary from 20.7V to 29V dependent on the state of charge of the battery and the conditions of use. A voltage-sensitive relay RLF is included to reduce the effect of this variation. The relay operates when the applied voltage rises above 25.5V (+0 -0.3V) and releases when the voltage falls to 23.5V (+0.3 -0V). In the unoperated, or 'low volts', condition RLF1 is closed and RLG energised. RLG1 short-circuits R103a, R103b in series with X1 primary and RLG2 short-circuits R102 in the heater line. In the operated or

'high volts' condition these resistors are in circuit and tend to reduce the effect of the change in battery volts on the output voltages of the p.s.u.

47. SKTH supplies 24V d.c. input to the Receiver R210 p.s.u. via pin A. If SF is off and the Receiver R210 p.s.u. is on SKTH-M is connected to +24V in the receiver. Voltage-sensitive relay RLF can then be utilised to energise, via SKTH-J and RLF1, the coil of a relay in the receiver similar in action to RLG. When both p.s.u. are on this relay will operate simultaneously with RLG.

Receiver connections

48. In addition to the input and voltage control connections SKTH is used to connect the receiver output, via the sender relays and switching, to the phones. (SKTH pins K and L and SKTA pins J and E). A 6.3V heater supply for the intercomm amplifier is obtained from a winding on the Receiver R210 d.c. p.s.u. vibrator transformer and coupled to the sender via SKTH pins E and F and SKTA-F. H.T. for the intercomm amplifier is coupled from the receiver p.s.u. by SKTH pins C and D and SKTA-H. Both h.t. and l.t. are referred to chassis.

SUPPLY UNIT, RECTIFIER, NO 30

BRIEF TECHNICAL DESCRIPTION

Introduction

49. The Supply unit, rectifier, No 30 (a.c. p.s.u.) is designed to provide all the supplies necessary for the Sender C11 and the Receiver R210 from an a.c. input of 100-120V or 200-240V. It is intended for use when this combination is used as a ground station.

Construction

50. The a.c. p.s.u. is the same size as the sender but weighs more (app. 60 lbs). No blower is fitted, cooling being achieved by air vents on the rear and side of the case. Voltage selection is made by a rotary switch with a slotted spindle and indication of the voltage setting is given by a numbered disc visible through a window on the front panel.

Controls

(Fig 5)

51. An engraved plate on the front panel provides the key to all switches, lamps, fuses etc. The controls on the front panel consist of:-

- | | |
|----|---|
| SG | A double-pole double-throw toggle switch which connects the mains to sender transformer T125. |
| SH | A double-pole double-throw toggle switch which connects the mains to receiver transformer T126. |
| SJ | A 6-position rotary switch which selects voltage taps of 100, 110, 120 and 200, 220, 240V. |

- IILP125 Indicator lamp lit by 19V sender heaters supply.
- IILP126 Indicator lamp lit by 6.3V receiver and intercomm heaters supply.
- PLK A 3-way Mk 4B plug for the mains input.
- SKTA A 12-way Mk 4B socket (orientation 1) which connects all the voltages required by the sender and intercomm amplifier. It also connects the receiver phones to sender.
- SKTH A 12-way Mk 4B socket (orientation 2) which connects h.t., l.t. and bias supplies to the Receiver R210 and connects the receiver phone output for linking to SKTA.

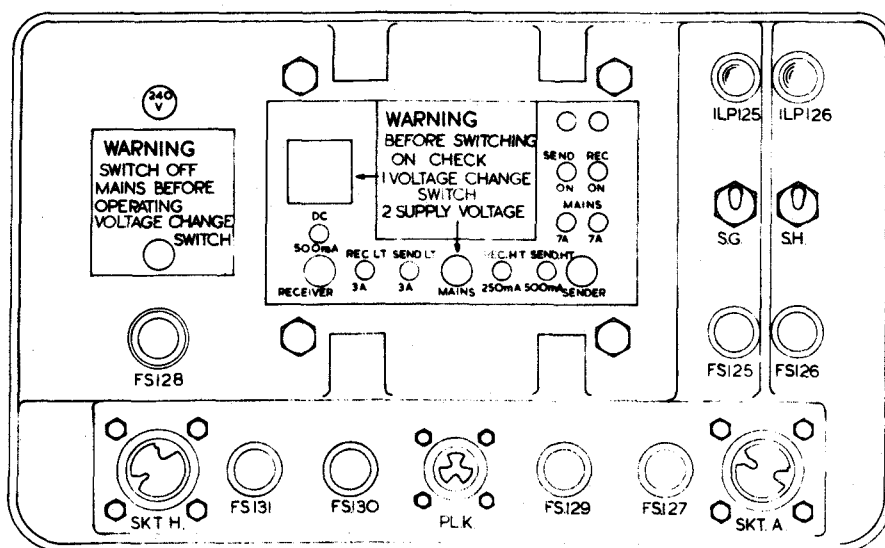

T D122-1
1-5

Fig 5 - A.C. p.s.u. front panel controls

DETAILED TECHNICAL DESCRIPTION

(Fig 2017)

52. Both sender and receiver mains transformers (T125 and T126) have double-wound primaries. Voltage selector switch SJ connects the windings of each primary in parallel across the supply on the 100, 110 and 120V taps and in series on the 200, 220 and 240V taps.

Sender supplies

53. Switch SG connects the mains supply via SJ to the sender transformer T125 which has four secondary outputs used as follows:-

- (a) A 740V-0-740V winding connected to valves V125 and V126 which provide full-wave rectification. This gives a 530V d.c. output, smoothed by choke-input filter L125, C129, C130 and C131, between SKTA-A and SKTA-B when RLJ is energised by earthing the send/receive line SKTA-L. R125 and R126 form a bleeder across the 530V supply. A 300V d.c. stabilised supply is obtained across V128 and V129 when a sender is connected; the dropping resistor from the +530V is in the sender.
- (b) A 5V heater supply for rectifiers V125 and V126.
- (c) A 30.5V winding connected to a full-wave bridge metal rectifier MR125. The rectified output, filtered by L126, C125 and C126, supplies +24V d.c. to RLJ and, via FS128 and SKTA-K, to the sender relays.
- (d) A 19V heater supply fed to the sender by SKTA-M. This supply is used for the SEND ON indicator lamp IIP125.

Receiver supplies

54. Switch SH connects the mains via SJ to transformer T126 which has three secondary outputs used as follows:-

- (a) A 255-0-255V winding connected to a full-wave rectifier V127. The rectified output is filtered by L127 and C128, fed as 175V h.t. to the sender for the intercomm amplifier by SKTA-H and to the receiver by SKTA-D.
- (b) A 6.3V winding supplying intercomm amplifier heaters through SKTA-F and receiver heaters through SKTH-F. This supply is used for RECEIVER indicator lamp IIP126.
- (c) A 26.5V winding half-wave rectified by MR126. The capacity-input filter C132, R130 and C133 gives a d.c. output of -30V fed as a bias supply to the receiver by SKTH-H.

55. Pins K and L of SKTH and pins J and E of SKTA are used to feed the receiver output to the phones through the sender switching

AERIAL TUNING UNIT NO 7

Introduction

56. The Aerial tuning unit No 7 is designed to match the output impedance of the Sender C11 to the impedance of the various aerials which can be used with it. Tables of matching and tuning figures for different types and lengths of aerial are included in the User Handbook. When the sender is used with dipole aerials the tuning unit is not required.

BRIEF TECHNICAL DESCRIPTION

Principles of operation

57. The A.T.U. No 7 consists of a loading inductor which tunes with a variable capacitor and the aerial capacitance to give maximum aerial current. The input from the sender is fed across the variable capacitor so that by varying the LC ratio the impedance step-up can be altered to give correct matching.

Construction

58. The unit is housed in a sealed cast alloy case and fitted with a desiccator. The polythene-insulated aerial terminal and the earth connection are fitted on the rear of the case. Connection from the loading inductor to the aerial terminal is made by connecting the protruding end of the coil shaft to a spring clip on the rear of the case. Since all other components are attached to the front panel the unit can be removed simply by undoing the four nuts and bolts securing the case to the front panel. A trip counter gives a three figure TUNE indication and the MATCH position is shown by a dial calibrated 0-20.

Controls

59. Controls on the front panel consist of:-

- MATCH Varies ganged capacitor. Switches series fixed inductor in circuit for 180° and shorts it out for the remaining 180°.
- TUNE Varies loading inductor.
- LOCK Locks both MATCH and TUNE drives and switches off the indicator lamps when in lock position.
- PLA Connects cable from sender to a.t.u. (Burndept pattern 4 coaxial plug)

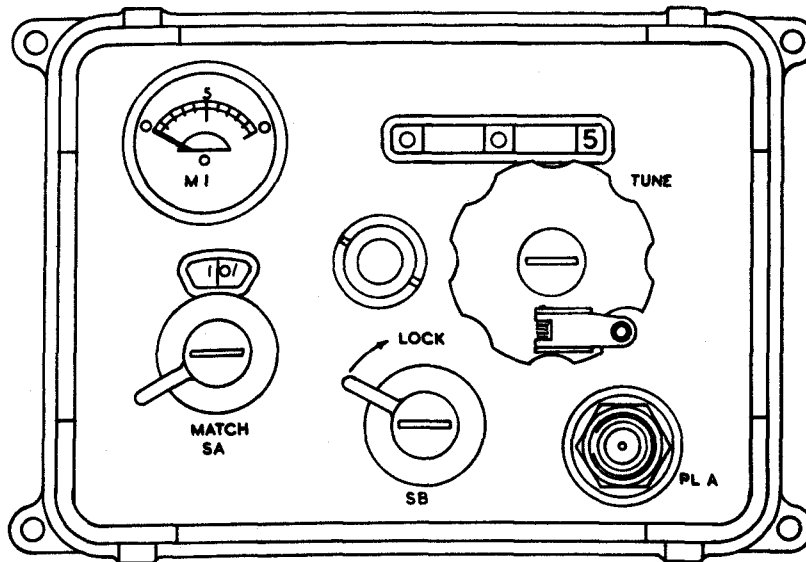

T $\frac{D122-1}{1-6}$

Fig 6 - A.T.U. front panel controls

DETAILED TECHNICAL DESCRIPTION

(Fig 2019)

60. The input to PLA is fed via C52 (sender) and a coaxial connector from the 70Ω tap on the appropriate coil in the sender p.a. output. A voltage for dial lights (ILP1 and ILP2) is also fed along this connector. The r.f. choke (L4) isolates the signal output and C2 blocks the lighting voltage from the aerial. A switch (SB), operated by the LOCK mechanism extinguishes the lights when the scales are locked.

61. The aerials with which the a.t.u. is designed to be used are chosen so that at the operating frequency they will present a capacitive reactance. Tuning inductor (L1) and variable capacitor (C1) with aerial capacitance can be tuned to the frequency used by varying L1 and/or C1. If the ratio of L1 to C1 be varied the effective impedance of the aerial can be matched to the 70Ω input. In practice MATCH (C1) is set from tables provided for the particular aerial and frequency in use and TUNE (L1) for resonance, ie maximum current indication on meter.

62. The input from PLA is connected across a two-gang capacitor (C1). The two sections of C1 are connected in parallel and it rotates through 180° (0-10 on dial) with a fixed inductor (L2) short-circuited then through a further 180° (10-20 on dial) with L2 in series with L1. This is accomplished by a switch (SA) which is cam-operated on an extension of C1 rotor shaft, and the switch blade is so shaped that, at the point of changeover, the sender output is disconnected momentarily to avoid arcing at the contacts.

63. Inductor L1 is wound with silver wire and rotates with the TUNE control. A fixed brush makes contact with one end of the coil and a moving brush moves axially along the coil with rotation so altering the amount of the inductor short-circuited. The moving brush has a double contact so that four turns are shorted out to screen resonances in the 'dead' part of the coil from the 'live' part.

64. The lead from C1 to L2 and L1 is passed through a toroidally wound inductor L3. The r.f. induced in this inductor is rectified by a germanium diode MR1, filtered by C4, R2 and C5 and fed to a $500\mu\text{A}$ meter M1. The values of resistors R2 and R3 are chosen to give approximately full scale reading with maximum sender output. Resistor R1 damps inductor L3 so tending to keep the meter reading constant over the band. C3 is fitted directly across M1 to decouple any stray r.f.

FILTER UNIT, R.F., NO 15

65. When the C11/R210 station is used in an installation including a v.h.f. equipment spurious responses from the v.h.f. transmitter may be picked up by the Receiver R210. Filter unit, r.f., No 15 is therefore fitted between the Sender C11 output plug and the A.T.U. No 7 input.

66. The circuit and layout of this filter unit are shown in Fig 2021. The filter characteristics give an attenuation of greater than 60dB at frequencies between 30 and 60Mc/s . The loss at high frequencies is not greater than 3dB at 16Mc/s .

EME 8/832

END of Part 1

