

STATION, RADIO, A13

TECHNICAL HANDBOOK - TECHNICAL DESCRIPTION

Errata

Note: This Page 0, Issue 2 supersedes Issue 1, dated Jul 72 and must be filed immediately in front of Page 1, Issue 3, dated 12/70

1. The following amendments must be made to the regulation.

2. Page 24, Fig 7.

Value of C6; Delete: '1.5-61.5pF'

Insert: '1.5-46.5pF'

3. Page 77, Fig 45.

Insert a diode symbol across relay R1A, cathode connection to pin b, anode connection to pin a, and annotate it D1.

T/61136/D & M
EME/8c/2185 Tels

CONDITIONS OF RELEASE	
(Applicable to copies supplied with Ministry of Defence approval to Commonwealth and Foreign Governments)	
1.	This information is released by the United Kingdom Government to the recipient Government for Defence purposes only.
2.	This information must be accorded the same degree of security protection as that accorded thereto by the United Kingdom Government.
3.	This information may be disclosed only within the Defence Department of the recipient Government, except as otherwise authorized by the Ministry of Defence.
4.	This information may be subject to privately owned rights.

STATION, RADIO, A13

TECHNICAL HANDBOOK - TECHNICAL DESCRIPTION

This EMER must be read in conjunction with Tels F 142 Part 2 which contains figures and tables to which reference is made.

Note: This Issue 3 supersedes Issue 1, Pages 0, dated 31 Aug 66, 01, dated 28 Apr 67, 02-03, dated 30 May 67, 04, dated 9 Apr 69, 05, dated Dec 69, and Issue 2, Pages 1-77, and 1001-1004, dated 14 Feb 66. The regulation has been revised throughout.

CONTENTS

	<u>Para</u>
INTRODUCTION	
Role and purpose of equipment	1
Main parameters	3
Composition of stations	12
Coding and identification data	13
Testing and repair facilities	17
TRANSMITTER-RECEIVER, RADIO, A13	
BRIEF TECHNICAL DESCRIPTION	
Principles of operation	22
Calibrate	23
Receive	29
Transmit	34
Construction	41
Controls	52
DETAILED TECHNICAL DESCRIPTION	
Receiver	
R.F. amplifier	53
First local oscillator and buffer amplifier	62
First mixer	66
First i.f. amplifier	71
Second local oscillator	75

CONTENTS - (cont)

	<u>Para</u>
Second mixer	79
Second i.f. filter	82
Second i.f. amplifier	88
A.M. and a.g.c. detector and a.g.c. amplifier	93
Automatic and manual r.f. gain controls	100
Limiter and discriminator	103
Headphone amplifier	113
Beat frequency oscillator	117
Receiver voltage stabilizer	121
Transmitter	
Master oscillator - buffer amplifier	126
Driver, frequency doubler and power amplifier	131
Reactance transistor and automatic frequency control	141
Automatic frequency control delay	151
Phase modulation	157
Amplitude modulation	161
Sidetone	166
Automatic modulation control	171
Relay delay and transmit-receive switching	178
Transmit stabilizer	183
Calibrator	184
Crystal oscillator	185
Decade dividers	187
Calibrator amplifier	189
Calibrator stabilized supply and a.g.c.	190
Meter circuit	192
Dial illumination	195
Secondary batteries	198
Temperature compensation	200
Remote control	
General	204
Receive	206
Transmit RT	208
C.W. transmit	211

CONTROL, TRANSMITTER-RECEIVER, REMOTE (R.C.U.)

BRIEF TECHNICAL DESCRIPTION

General	212
Construction	217
Controls	219

TUNER, R.F., ANTENNAE

BRIEF TECHNICAL DESCRIPTION

General	220
Construction	224
Controls	227

DETAILED TECHNICAL DESCRIPTION

Matching	228
Metering	230

CONTENTS - (cont)

	<u>Para</u>
HARNESS ADAPTOR UNIT (H.A.U.), Mk 2	
BRIEF TECHNICAL DESCRIPTION	
General	234
Construction	237
Controls	239
DETAILED TECHNICAL DESCRIPTION	
Voltage and current regulator	240
Headphone amplifier	243
Microphone attenuator	244
AMPLIFIER, R.F., No 12, Mk 1	
BRIEF TECHNICAL DESCRIPTION	
General	246
Controls	249
Construction	250
DETAILED TECHNICAL DESCRIPTION	
Transmit-receive switching and relay operation	256
R.F. amplifier	263
D.C. converter	270
STABILIZER, VOLTAGE, TRANSISTOR TYPE (V.R.U.)	
BRIEF TECHNICAL DESCRIPTION	
General	274
Construction	276
DETAILED TECHNICAL DESCRIPTION	
Generator and rectifier	291
Voltage and current regulation	296
Overwind protection and indicator lamp circuit	305
AMPLIFIER, R.F., No 12, Mk 2	
BRIEF TECHNICAL DESCRIPTION	
General	311
Construction	315
Controls	320
DETAILED TECHNICAL DESCRIPTION	
D.C. supplies	321
Relay switching	325
Equalizer circuits	328
R.F. amplifier	330
Filters	334

CONTENTS - (cont)

	<u>Para</u>
CHARGER, BATTERY RESISTANCE	
BRIEF TECHNICAL DESCRIPTION	
General	336
Construction	339
Controls	341
DETAILED TECHNICAL DESCRIPTION	342

LIST OF TABLES

<u>Table</u>		<u>Page</u>
1	Station equipment	9
2	Front panel controls	15
3	R.C.U. controls	49
4	Tuner, r.f., controls	50
5	Harness adaptor unit, controls	56
6	R.F.A. No 12, Mk 1, controls	59
7	R.F.A. No 12, Mk 2, controls	73
8	Charger, battery resistance, controls	76

LIST OF FIGURES

<u>Fig</u>		<u>Page</u>
1	Example of cable identification	7
2	Interior layout of film scale unit	14
3	Layout of controls and connections	18
4	Receiver r.f. amplifier, simplified circuit	19
5	First local oscillator and buffer amplifier, simplified circuit	21
6	First i.f. amplifier, simplified circuit	23
7	Second local oscillator, simplified circuit	24
8	Second mixer, simplified circuit	25
9	Mechanical filter construction	26
10	Second i.f. amplifier, a.g.c., simplified circuit	27
11	A.M. detector and a.g.c. detector/amplifier, circuit diagram	27
12	Automatic and manual r.f. gain controls, simplified circuit	29
13	Limiter and discriminator, circuit diagram	30
14	Limiter and discriminator, simplified circuit	30
15	Headphone amplifier, simplified circuit	31
16	Receiver voltage stabilizer, circuit diagram	33
17	Driver, frequency doubler, simplified circuit	34
18	Reactance transistor and a.f.c., simplified circuit	36
19	A.F.C. delay, circuit diagram	37
20	Microphone amplifier, simplified circuit	38
21	Amplitude modulation, simplified circuit	39
22	Automatic modulation control, simplified circuit	41
23	Relay delay, simplified circuit	42
24	Meter circuitry	44
25	Remote control, receive, simplified circuit	46
26	Remote control, transmit RT, simplified circuit	47
27	R.C.U. controls	49
28	Tuner, r.f., interior view	51
29	Tuner, r.f., controls	52

CONTENTS - (cont)

LIST OF FIGURES - (cont)

<u>Fig</u>		<u>Page</u>
30	Tuner, r.f., tuning circuit, simplified	54
31	Tuner, r.f., metering, simplified circuit	54
32	Harness adaptor unit, controls	56
33	H.A.U., voltage and current regulator, simplified circuit	57
34	SRA13 installed in vehicle	58
35	R.F.A. No 12, Mk 1, controls	60
36	R.F.A. No 12, Mk 1, relay delay, simplified circuit ...	62
37	V.R.U. layout and controls	64
38	V.R.U. voltage and current regulator, simplified circuit	65
39	Generator, d.c., controls	67
40	Generator, d.c., generator and rectifier, simplified circuit	68
41	Generator, d.c., voltage and current regulation, simplified circuit	70
42	Generator, d.c., overwind protection and indicator lamp, simplified circuit	71
43	R.F.A. No 12, Mk 2, controls	73
44	Charger, battery resistance, controls	77
45	Charger, battery resistance, circuit	77
2001	TRA13, calibration and tune r.f., block diagram	1001
2002	TRA13, receiver block diagram	1002
2003	TRA13, transmitter block diagram	1003
2004	TRA13, block diagram	1004

INTRODUCTIONRole and purpose of equipment

1. The SRA13 is a lightweight manpack h.f. radio set which can also be used as a ground or vehicle station.
2. The set will be used for infantry net communications when circumstances prevent the use of v.h.f. equipment. It may also be used by ground forces in the early stages of airborne landings to establish communications to supporting ground formations.

Main parameters

3. The station operates in the frequency band 2-8MHz and with a choice of voice phase or amplitude modulation or c.w. operation using hand keyed morse up to 25 w.p.m.
4. It comprises a basic transmitter-receiver unit which gives approximately 1.5W of transmitter output power on c.w. or phase modulation and 0.8W on a.m. Additionally an r.f. amplifier is provided which steps up the transmitter power to 16W on c.w. or ph.m. or 8W on a.m.
5. A separate tuner, radio frequency is provided which allows the transmitter-receiver, with or without r.f. amplifier, to be used with the following antennae:
 - a. 8 ft whip either on man, ground or vehicle.

- b. 12 ft rod on vehicle.
 - c. 26 ft vertical antenna.
 - d. End fed either $\lambda/4$ or $3\lambda/4$ in length.
 - e. Ground plane antenna.
6. In addition a dipole antenna system is provided which may be connected directly to the antenna sockets of the low power transmitter-receiver or the r.f. amplifier. A lightweight 18 ft mast is also provided which can be used to support one end of the end fed antenna, the centre of the dipole, or with a whip antenna adaptor, to provide a 26 ft vertical antenna. The tuner may also be mounted on the ground spike and used with up to 50 ft of coaxial cable as a remote antenna, a counterpoise earth system is also provided.
7. Both the transmitter-receiver and the r.f. amplifier are supplied by internal 12V secondary batteries.
8. These batteries may be charged by equipment supplied with the station, viz:
- a. A hand generator which can be used to float charge the batteries in use or to recharge spare batteries.
 - b. A voltage regulating unit (VRU) which allows spare batteries to be charged from any source of nominal 24V d.c. A Charger, battery resistance is also provided which allows up to five VRU to be operated from various petrol driven generators.
9. Additionally a morse key and two types of audio equipment are provided, these being:
- a. A nylon handset.
 - b. A double headset with a boom microphone.
10. Where it is required to install the set in a vehicle, a subsidiary unit known as the harness adaptor unit is used. This unit provides the following facilities:
- a. A shock-protection mounting for the set.
 - b. An audio amplifier to increase the phone output of the SRA13 to a level suitable for vehicular use.
 - c. Necessary matching to allow the normal vehicle type audio gear to be used with the SRA13.
 - d. Conversion of SRA13 audio connections to those suitable for connection to the Radio control harnesses, type A and B.
 - e. A voltage converter and regulator for providing the 12V supply for the A13 from the vehicle 24V supply.
11. The set may be remote controlled at distances up to 880 yd, the distant remote control unit being connected to the set by D10 cable. No local remote

control unit is required, the necessary circuitry being included in the transmitter-receiver.

Composition of stations

12. The complete equipment comprises a number of separate items which may be assembled to form various types of stations. The items of equipment either clip or strap on to a special tubular steel rucksack type carrier. Table 1 lists the basic types of station and their composition.

Coding and identification data

13. The component coding of the major items of the SRA13 follows this system:

a. Printed circuit boards or assemblies whose circuit diagram is shown as a separate figure have their components numbered starting from 1, eg R1, C1 etc. Such boards or assemblies also carry an identifying number inside a ring, either on the copper side of the board or silk screen printed on the component side. In any text or diagram where reference to more than one board or assembly is made the relevant component is uniquely identified by the use of the board number as a prefix, eg 9R2 is number two resistor on the b.f.o. board.

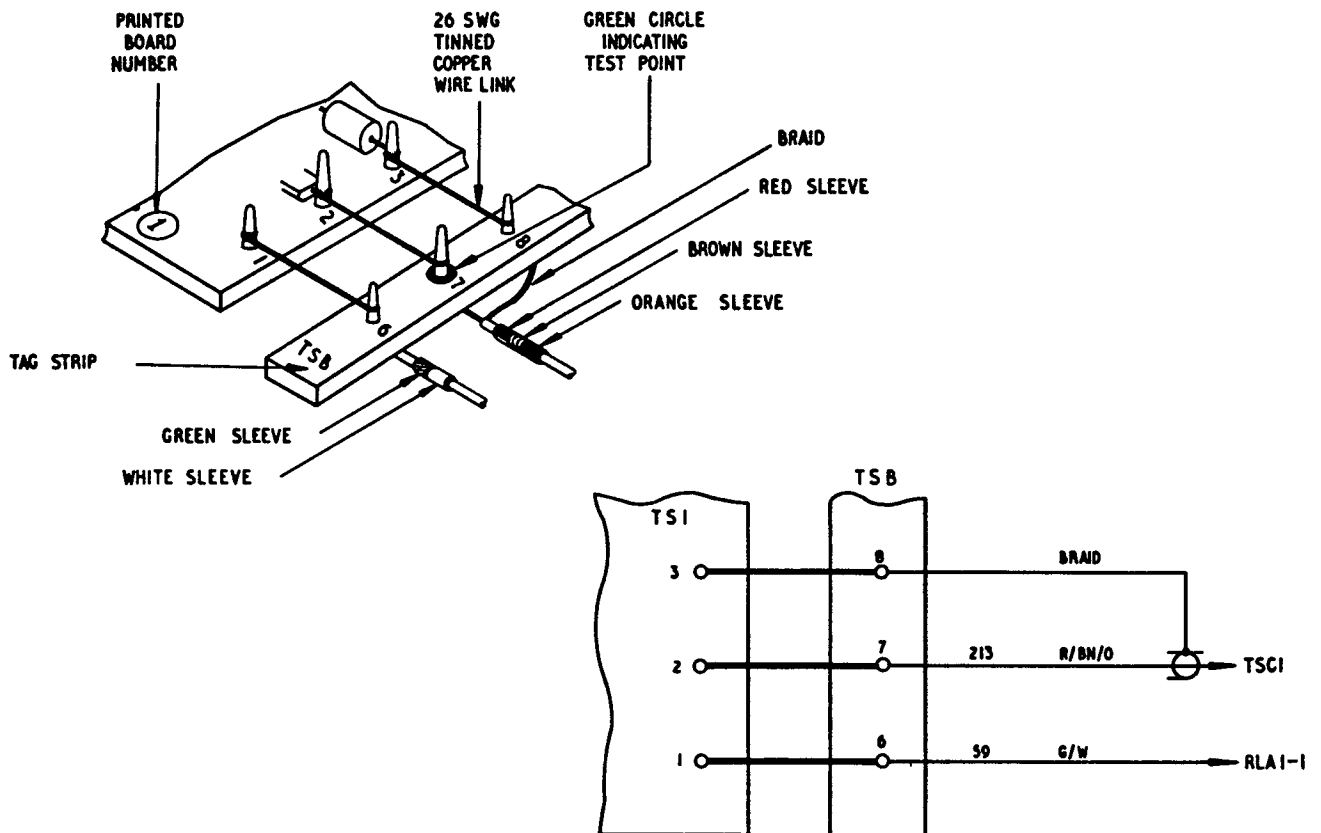

2105/05

Fig 1 - Example of cable identification

- b. Printed circuit boards have the component numbers printed between the mounting holes or pins and, if the component is present will normally be partly masked by the component. Exceptionally, a few component identifications are completely visible, and these can be used as datum points when comparing a board with a layout diagram. It has not been possible to leave all component references clearly visible due to the high component density of the SRA13.
- c. In certain units such as the hand generator, although the unit contains several printed boards, all appear on the same diagram. In such cases the component numbering starts at 1 and runs consecutively irrespective of the board on which the component appears. However, the boards bear a ringed number and this number is used as a prefix on the circuit diagram to indicate the board on which the component is located.
- d. Test points take two forms: those used frequently for alignment or specification tests are Oxley sockets which accept miniature test plugs, those test points used less frequently are in the form of double-length connection pins and are ringed in green.
- e. Temperature-compensating capacitors are marked TC: see para 201.

14. Connections to printed circuit boards are made either via short 26 S.W.G. tinned copper wire links to distribution terminal strips or, in some cases, directly from the cableform to the board connecting pin. In the latter case, wherever possible, a sleeve or lug is crimped on to the cableform wire and the lug is soldered to the connecting pin, this prevents fraying of the fine multistrand wires used in the cableform.

15. Cableform terminations are identified by numbers on the circuit/wiring diagrams. These numbers are coded by coloured sleeves at the end of the cableform wires, the standard resistor colour code being used. Fig 1 shows a typical example.

16. In the case of the transmitter-receiver unit a complete circuit diagram showing every component would be too large and complex to be easily read. Instead a combined block-interconnection diagram (Fig 2503 and 2504) has been produced. This illustrates the overall circuit action and permits fault diagnosis to board level. For Field repairs (2nd line) which are limited to the diagnosis and replacement of faulty boards this diagram is adequate. Detailed circuitry and layout of individual boards are shown on individual diagrams.

Testing and repair facilities

17. Unit repairs are to be confined to the exchange of sealed items of the station and ancillaries such as audio gear etc. The faulty item in a station can be diagnosed by systematic observation without the use of any special functional test set. Suitable charts are contained in the User Handbook (Army Code No 13120).

18. Second line Field repairs is normally to be confined to the diagnosis of a faulty printed board or assembly and its replacement. The faulty boards or assemblies are to be repaired only at workshops designated to carry out such repairs.

19. The specification testing and fault diagnosis of a board can be carried out using the normal range of test equipment held by Field workshops.

Certain additional test boxes, connectors etc will be required, details of which are given in Tels F 144.

20. Workshops which are designated to carry out repairs to boards or assemblies are provided with special test equipment to allow printed boards or assemblies to be tested to production standards.

21. The batteries, which are of sealed construction, are not repairable. With normal use they should be virtually indestructible and should be capable of at least 200 charge/discharge cycles before they show signs of not holding a full charge. Tels F 144 gives a load test for the batteries and the limit at which they should be condemned as unserviceable.

Table 1 - Station equipment

Equipment	1 man low power	2 man high power	3 man high power	1 man high power	Vehicular high power	Spare battery kit
(a) Transmitter-receiver, radio, A13	1	1	1	1	V	
(b) Battery	1	1	1	1	V	X
(c) Tuner, r.f., antennae	1	1	1	1	V	
(d) Antenna, collapsible, 7 ft	1	1	1	1		
(e) Adaptor, antenna, adjustable angle for (d)	1	1	1	1		
(f) Antenna with reel, 150 ft	1	1	1	1		
(g) Boom microphone and receiver headgear	1	1	1	1		
(h) Microphone and receiver handset	1	1	1	1		
(j) Morse key	1	1	1	1		
(k) Ground spike and counterpoise	1	1	1	1		
(l) Coaxial connector (a)-(c)	1	1	1	1	V	
(m) Throwing cord	1	1	1	1		
(n) Pouch for item (d)-(m)	1	1	1	1		
(o) Amplifier, r.f., No 12		2	2	1	V	
(b) Battery		2	2	1	V	
(p) Hand generator		2	2			
(q) Tree fixing screw for (p)		2	2			
(r) Coaxial connector (o)-(c)		2	2	1	V	
(s) 6-way connector (a)-(o)		2	2	1	V	
(t) 2-way connector (p) to (a) or (b)		2	2			
(u) Pouch for items (q)-(t)		2	2			
(v) 18 ft mast and accessories in case			3			
(f) Antenna with reel, 150 ft			3			
(w) Junction dipole used with 2(f)			3			

Table 1 - (cont)

Equipment	1 man low power	2 man high power	3 man high power	1 man high power	Vehicular high power	Spare battery kit
(x) 50 ft coaxial connector (a) or (o) to (w) or (a) or (o) to (c) when remote			3			
(y) Control, transmitter-receiver, remote			3			
(z) 100 ft of D10 cable (a)-(y)			3			
(aa) Pouch for items (f) and (w)-(z)			3			
(ab) Pouch for items (d)-(m) and (r)-(s)				1		
(ac) Harness adaptor					V	
(ad) 6-way connector (o)-(ac)					V	
(ae) Stabilizer, voltage, transistor type						X
(af) 2-way connector (ae) to 24V d.c.						X
(ag) Webbing for carrying items (ae), (b) and (af)						X

Note: Abbreviations 1 = 1st man load; 2 = 2nd man load; 3 = 3rd man load; V = vehicle borne; X = As convenient

TRANSMITTER-RECEIVER, RADIO, A13

BRIEF TECHNICAL DESCRIPTION

Principles of operation

22. The block diagrams illustrate the stages in circuit under the following circuit conditions:

- a. Calibrate; system switch to CHAN ADJ or CURSOR ADJ, Fig 2001.
- b. TUNE RF, Fig 2001.
- c. Receiver, Fig 2002.
- d. Transmitter, Fig 2003.
- e. TRA13, Fig 2004.

Numbers inside circles on these diagrams refer to board numbers.

Calibrate
(Fig 2001)

23. Fig 2001 shows the circuit arrangement in the CURSOR ADJ and CHAN ADJ positions of the system switch 28S3.

24. The calibrating signals are derived from a 1MHz crystal oscillator whose output is fed into two binary decade divider stages producing outputs of 100kHz and 10kHz in the form of narrow pulses with harmonics throughout the h.f. band.

25. When the system switch is in the CURSOR ADJ position a spectrum of 100kHz harmonics is passed through the receiver circuits which are switched as for phase modulation reception. The centre zero tuning meter is connected to the output of the discriminator, the set is then tuned for zero meter deflection at the 100kHz point nearest to the required frequency. The cursor, which may be moved mechanically by the CURSOR knob, is adjusted to the correct calibration mark on the channel kHz film scale.

26. The system switch is now set to the CHAN ADJ position, where a spectrum of 10kHz multiples is fed into the receiver circuits. Tuning to the 10kHz point nearest to the required frequency can be achieved by first setting the scale in an approximately correct position against the cursor and then tuning accurately for zero deflection on the meter.

27. The cursor can now be reset accurately and the film calibration markings allow adjacent channels at 5 or 2.5kHz spacing to be set with precision, these coinciding respectively with the crest or trough positions of the sawtooth shaped markings.

28. The system switch is now set to the TUNE RF position, in which position the transmitter is operating but the antenna is disconnected. The output of the transmitter is loosely coupled into the receiver and by adjustment of the RF tuning dial (upper drum) the tuning meter can be adjusted for centre zero; in this condition the master oscillator frequency is set to the receiver frequency which has already been accurately set by reference to the in-built calibrator. In this switch position the a.f.c. circuits are not functioning.

Receive
(Fig 2002 and 2004)

29. The SRA13 is a double superheterodyne receiver operating in the frequency band 2-8MHz. The first i.f. is variable from 1.450-0.950MHz. The first oscillator consists of twelve crystal controlled 0.5MHz steps in the range 3.450-8.950MHz, the appropriate step being selected by the RANGE MC/S switch. The second local oscillator is continuously tunable in the frequency range 1.405-1.905MHz and the second i.f. output from the second mixer is 455kHz.

30. This second i.f. is fed into the mechanical filter which provides the main selectivity of the receiver and the output from the filter is amplified in the second i.f. amplifier.

31. The amplifier output is connected to the a.m./a.g.c. detector and the limiter. The a.g.c. detector output is fed to a d.c. amplifier whose output is fed back to control the gain of the receiver. The a.f. output from the a.m. detector is fed via an amplifying stage to the system switch. The limiter output feeds the discriminator, the a.f. output of which is fed via a frequency correcting network to the system switch.

32. According to the modulation system selected by the system switch the corresponding a.f. output is fed from the system switch to the headphone

amplifier and thence via the a.f. gain control to the headphone socket and audio gear.

33. On c.w. the b.f.o. is operational, its signal is fed to the input of the limiter where it mixes to provide an audio beat note, the frequency of which can be adjusted by the CW TONE control. On c.w. the a.g.c. system is inoperative, the r.f. gain of the receiver being controlled by the manual GAIN control.

Transmit
(Fig 2003 and 2004.)

34. The master oscillator tunes over the frequency range 2-4MHz. Over this range its output is amplified by the buffer and p.a. circuits to provide the carrier output.

35. For the 4-8MHz range the master oscillator output is fed via a frequency doubler (in the p.a. unit) to the buffer and p.a. stages, the tuned circuits for which have been selected by the RANGE MC/S switch.

36. Part of the transmitter output is fed into the receiver and the resulting d.c. discriminator output is proportional to the difference between the master oscillator and the receiver frequencies. This d.c. voltage is connected via the a.f.c. loop to the variable reactance stage which is connected across the master oscillator tuned circuit. The polarity of this a.f.c. signal is such that it alters the reactance to make the master oscillator frequency equal the receiver frequency. On transmit the input to the 2nd i.f. filter is earthed and the signal passed via the diode switch, thus widening the pass-band of the receiver and providing a wider capture band for the transmitter a.f.c.circuits.

37. On amplitude modulation, the microphone input is amplified by the microphone amplifier then, via an additional stage of amplification, is fed to the a.m. modulator output stages. The output of this stage is transformer-connected in the collector circuits of the p.a. stage for amplitude modulation. The output of the modulator is also rectified and, via the a.m.c. control stage, used to maintain the gain of the microphone amplifier on a.m. at a constant level.

38. On phase modulation the output from the microphone amplifier is fed to the base of the phase modulator (18TR1) and to the a.f. amplifier 12TR1 and 12TR2. The output from this amplifier is then rectified in the microphone amplifier, the resultant d.c. being used to provide a.m.c. bias. On c.w. the microphone amplifier is out of circuit.

39. Sidetone is provided as follows:

- a. A.M.: The output of the a.m. modulator is fed into the headphone amplifier (false sidetone).
- b. Ph.M.: The a.f. output of the receiver discriminator is fed into the headphone amplifier (true sidetone).
- c. The sidetone oscillator is connected to its supply on c.w. When the key is operated the oscillator produces a tone of approximately 1000Hz which is fed into the headphone amplifier (false sidetone).

40. The terms true and false sidetone indicate whether the presence of sidetone indicates radio transmission as in phase modulation or only audio circuit action as in the case of a.m. and c.w.

Construction
(Fig 2)

41. The Transmitter-receiver, radio, A13 is contained in a die cast magnesium case, with an aluminium front panel. The whole is a fully sealed unit and can be used anywhere in the world. Sealing is achieved by the use of a Hyclad gasket which is clamped between machined faces on the case and front panel. This type of gasket takes the form of a metallic ring, on to the upper and lower faces of which a rubber coating is bonded, allowing the use of a thinner case wall than with the conventional rubber ring gasket, giving important weight reduction.

42. The front panel carries the whole of the operational portion of the set, this can be sub-divided into three major sub-assemblies:

- a. Front panel assembly.
- b. Film scale unit, which also carries the majority of the circuitry.
- c. Calibrator tray.

43. The front panel assembly carries the following controls, CW TONE control, ON-OFF/GAIN control, cursor and meter. The windows (scales) and meter of this assembly are illuminated by neon lamps when the system switch is in the CURSOR ADJ, CHAN ADJ and TUNE RF positions. These neon tubes are driven by a small transistorized oscillator which is also mounted on the front panel. The sockets for antenna and audio connections, for battery and charging connections and the remote control terminals are also fitted to this panel. Interconnections between the front panel assembly and the film scale unit is by means of a 15-way plug and socket.

44. The film scale unit fits mechanically on to the front panel assembly by means of locating dowels and four securing screws. The unit also carries the spindles which actuate the lock, system switch, tuning control and megacycles switch; these pass through holes in the front panel and are secured and sealed by means of 'O' rings, nuts and washers.

45. The unit consists of a main magnesium casting (for lightness and strength) on to which are fitted all the necessary mechanical items, gears, drives, etc and also the majority of the printed circuit boards and the interconnecting cableforms and terminal strips.

46. The main tuning is achieved by means of a single tuning handle whose drive is transferred to either the kilocycles film scale and related gang, or the r.f. drum and its gang dependent upon the position of the LOCK knob, which in its mid position disengages both drives and at the same time locks both tuning capacitors in a fixed position. The megacycles switch operates a vertical film blind which reveals the relevant part of the kilocycles film scale and also displays the chosen megacycle digit.

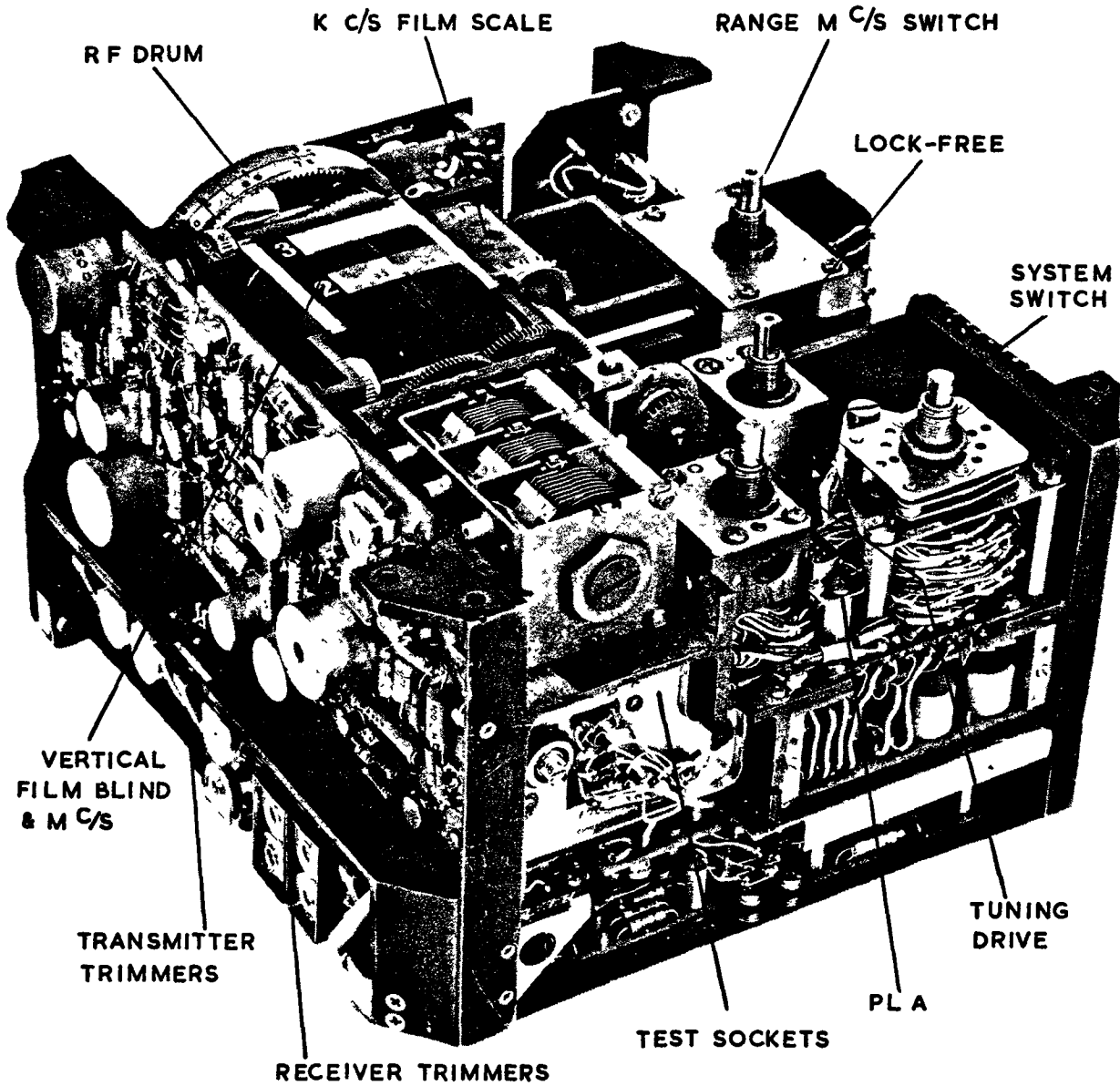

Fig 2 - Interior layout of film scale unit

47. All the circuitry, other than a few odd components such as transformers and a power transistor, is carried on printed wiring boards. Connections between these boards and the interconnecting cableform are by means of short 26 S.W.G. jumper wires between tapered pins on the boards and corresponding taper pins on terminal strips at the cableform terminations. By this means boards may be easily removed/replaced without unsoldering the thin multi-core flexible wires of which the cableform is made.

48. The film scale casting is so shaped such that whether it is attached to the front panel or not, roll-over protection is afforded to all the components mounted on the set, ie the unit can be laid on any face for maintenance purposes without risk of damage.

49. The calibrator tray attaches to the rear of the film scale unit. It is normally hinged to this unit, but the hinges allow easy removal of the tray if required. This tray carries three printed circuit boards as follows:

- a. 1MHz oscillator and calibrator amplifier.
 - b. Decade divider 23A, 100kHz output.)
 - c. Decade divider 23B, 10kHz output.)
- b. and c. are similar boards

50. The calibrator tray should rarely need removal from the film scale unit, since it is hinged so that when it is swung out it is still functioning, but access is given to the r.f. boards and the r.f. trimmers and slugs which are adjusted during the alignment of the r.f. stages of the transmitter and receiver.

51. The set is fitted with a 1.1/4 in. silica gel desiccator carried on a 3/4 in. 20 t.p.i. plug which screws into the front panel. This allows the desiccator to be changed without breaking the main gasket seal and the hole can also be used for fitting a seal testing plug.

Controls
(Fig 3)

52. The front panel controls are shown in Fig 3 and details are given in Table 2.

Table 2 - Front panel controls

Item	Function
System switch S3	<p>CURSOR ADJ - A spectrum of 100kHz harmonics is fed into the receiver allowing the cursor to be set to the 100kHz point nearest to the required frequency. Scale illuminated</p> <p>CHAN ADJ - A spectrum of 10kHz harmonics is fed into the receiver allowing adjustment to the nearest 10kHz point to the required frequency. Scale illuminated</p>

Table 2 - (cont)

Item	Function
System switch S3 (cont)	<p>TUNE RF - The master oscillator, p.a. and r.f. circuits are aligned to the receiver frequency set in previous operation. Scale illuminated</p> <p>PhM - The set is switched for use on telephony phase modulation</p> <p>AM - The set is switched for use on telephony amplitude modulation</p> <p>CW - The set is switched for c.w. operation using manual keying. The c.w. tone is operative on receive and a sidetone oscillator on transmit</p>
Meter M1	This provides a centre zero indication for tuning in the calibrating positions of S3 and indicates battery voltage on the Ph M, AM and CW positions of S3. The 'L' mark represents a battery voltage of 10
CW TONE 27C2	This allows variation of the audio note heard on c.w. reception
OFF-GAIN S2	This is a combined on/off switch and gain control. In the latter function it provides nine switched levels of r.f. gain on c.w., and a.f. gain on phase and amplitude modulation
RANGE MC/S S1	This allows selection of the requisite 500kHz section of the tuning range to be selected, the twelve ranges being indicated by the frequencies shown on the panel. This control also actuates the transverse blind which reveals the appropriate portion of the film scale and the MHz figure
CURSOR	This is a purely mechanical control which moves the cursor to the required position during calibration
Antenna socket SKD	This is a 50Ω coaxial socket which connects to the antenna tuning unit or directly to a dipole (for 10W power operation). When high power operation is required, it connects to the input socket of the Amplifier, r.f., No 12
LOCK control and TUNE control	In the central position both the RF and CHANNEL scales and gangs are locked and the TUNE knob is inoperative. In the RF FREE position the RF scale and gang are unlocked and, via a clutch, connected to the TUNE control. In the CHANNEL FREE position the channel scale and gang are unlocked and, via a clutch, connected to the TUNE control

Table 2 - (cont)

Item	Function
Audio sockets SKB and SKC	These are provided for the connection of the handset, headset or morse key and to the Amplifier, r.f., No 12, when high power operation is required
Power input plug PLA	This connects the set battery to the hand generator for float charging purposes and is used for direct operation from an external 12V battery
Remote control terminals	The 2-way cable from the distant remote control unit is connected to these terminals
CHANNEL scale	This consists of a film scale, running horizontally and a blind running vertically. The former carries two calibrated scales, the upper running from 0-500kHz and the lower from 500-1000kHz. The vertical blind exposes the requisite half of the horizontal scale and also carries the MHz figure
RF drum	This is calibrated in two bands 2-4MHz and 4-8MHz with sub-divisions at 100kHz and 200kHz respectively. These points allow the drum to be set up sufficiently accurately whilst CURSOR and CHANNEL adjust settings are made, it is tuned accurately by meter reference when the system switch S3 is in the TUNE RF position

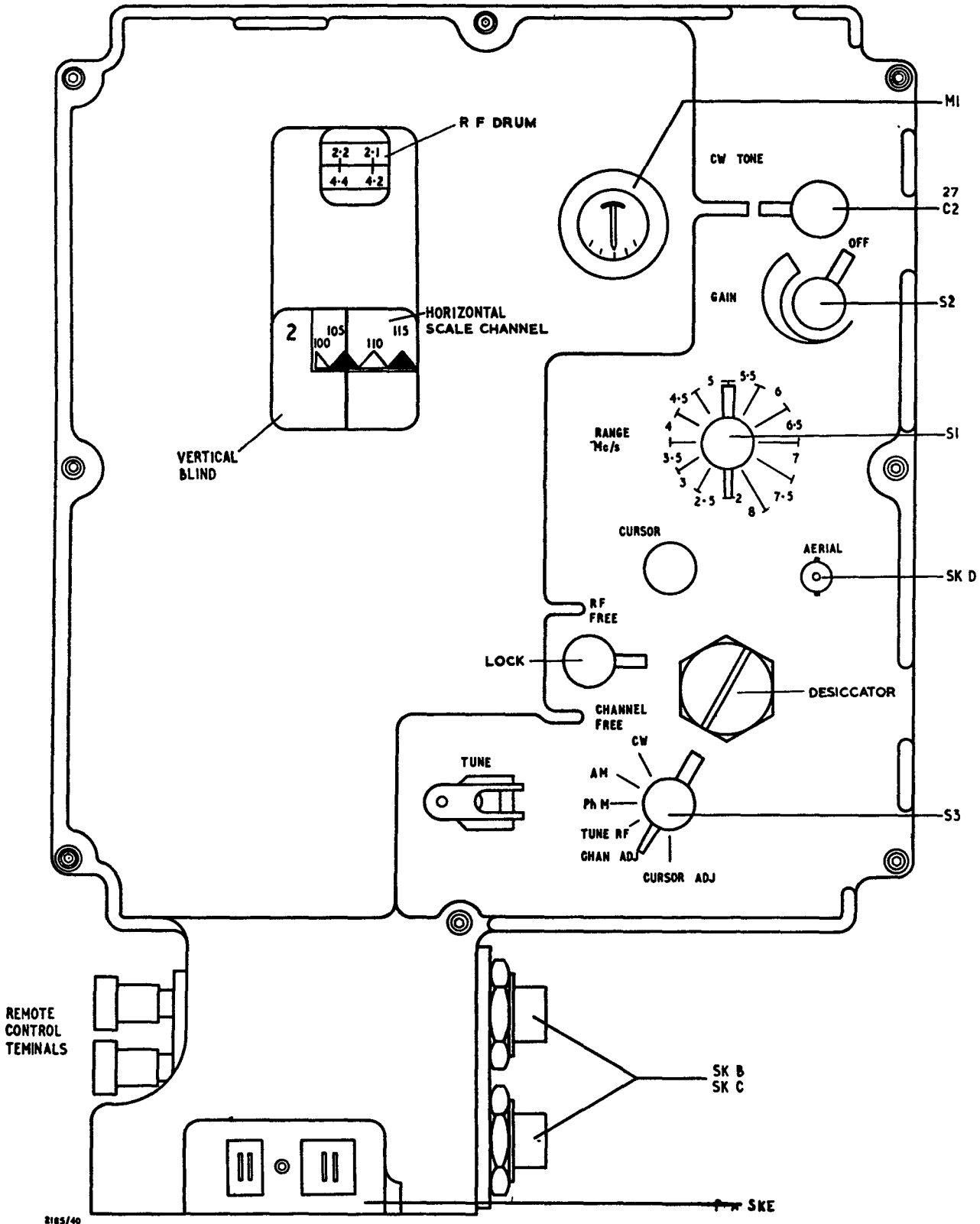
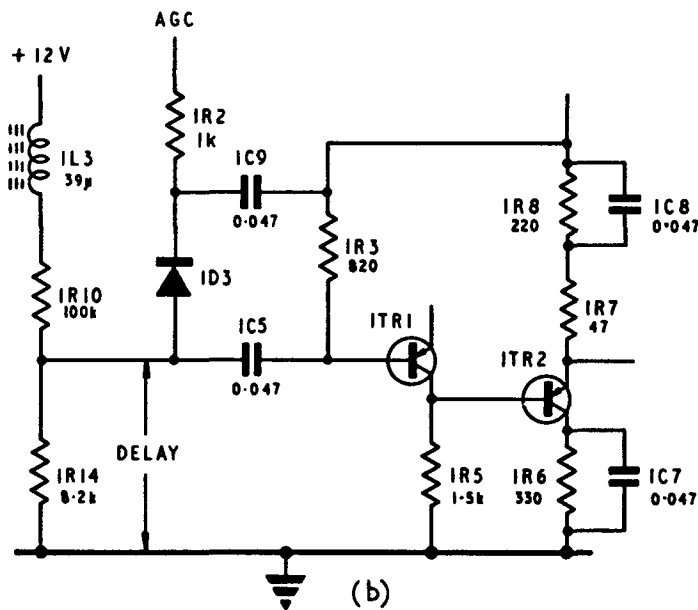
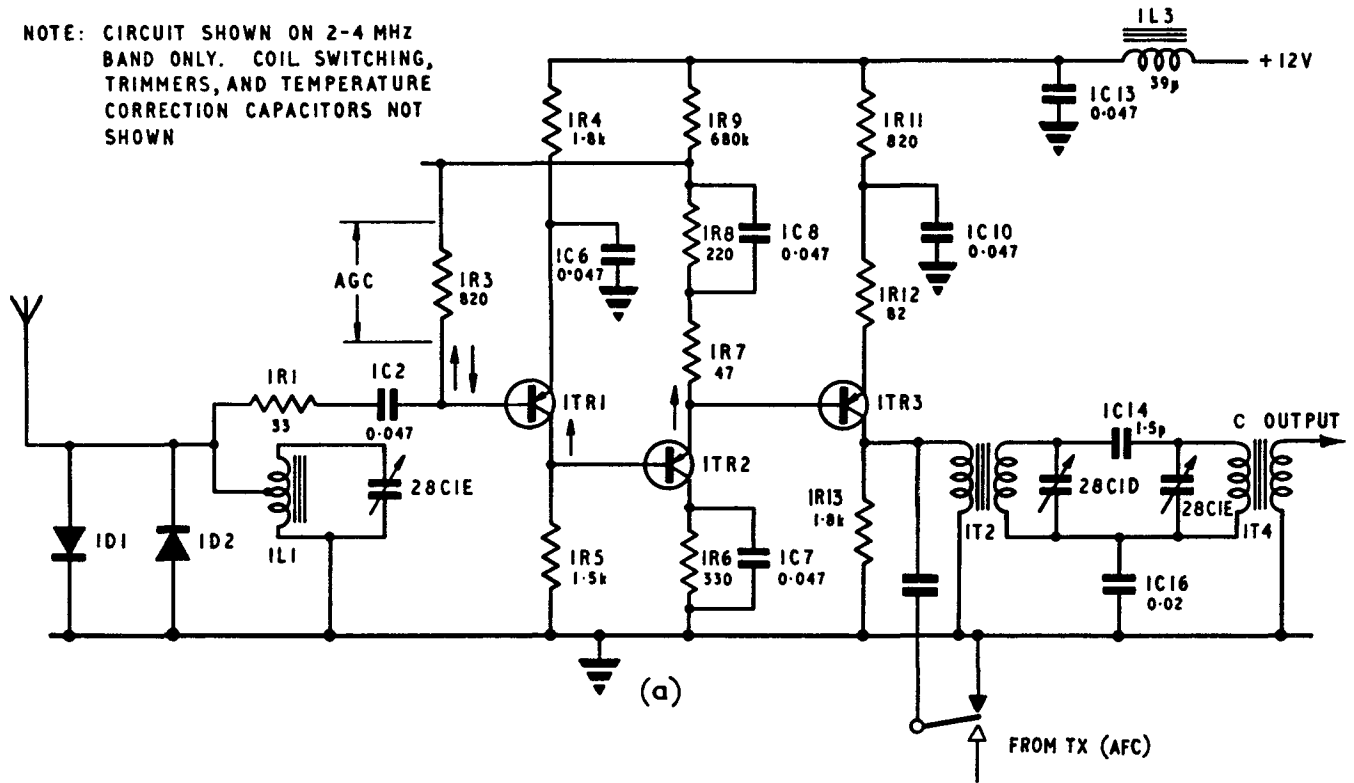

Fig 3 - Layout of controls and connections

NOTE: CIRCUIT SHOWN ON 2-4 MHz
BAND ONLY. COIL SWITCHING,
TRIMMERS, AND TEMPERATURE
CORRECTION CAPACITORS NOT
SHOWN



2185/79

Fig 4 - Receiver r.f. amplifier, simplified circuit

DETAILED TECHNICAL DESCRIPTION

Receiver

R.F. amplifier

53. This circuit is carried on printed wiring boards numbers 1a, 1b and 1c.

54. The gain of this stage (carried on board 1b) is produced by the d.c. coupled transistors 1TR1, 1TR2 and 1TR3. The first pair 1TR1 and 1TR2 give a gain of approximately 26dB and perform satisfactorily in the presence of high interfering signals. Blocking and cross modulation are reduced to a minimum consistent with good low noise performance. As these parameters are contrary the best possible compromise has been chosen.

55. The gain of 1TR1 and 1TR2 is effectively set by negative feedback produced by 1R7, 1R9 and 1R3 (1R8 is effectively shunted at r.f. by 1C8) and the a.g.c. Referring to Fig 4(b) it will be seen that 1D3 is in shunt with 1R3 to r.f. signals, when the a.g.c. voltage exceeds the delay bias developed across 1R14 diode 1D3 conducts and shunts 1R3 causing the gain of the amplifier to be reduced by up to 18dB.

56. The signal after amplification by 1TR1 and 1TR2 is passed to the third d.c. coupled amplifier 1TR3, this serves two purposes:

- a. Provides a gain of about 19dB giving an overall gain of the r.f. amplifier of some 40dB.
- b. Provides a constant output impedance to the circuits following the amplifier; the output impedance of the first two stages varies with the a.g.c. level.

57. The selectivity of the stage, the coils of which are carried on board 1a, has been achieved by the single tuned circuit 1L1 (1L2) and 28C1E at the input to the amplifier and the overcoupled pair 1T2 (1T1) and 28C1D and 1T4 (1T3) and 28C1C. The coupling is a mixture of top and bottom coupling, top coupling being by 1C14 (1C15) and the bottom by 1C16 (1C19), these giving a coupling factor (QK) of about 2 over the band.

58. The input single tuned circuits 1L1 and 1L2 and the input coils of the over-coupled pair 1T1 and 1T2 are short circuited when not in use, avoiding spurious resonances in the tuning range.

59. The receiver is protected against very high voltages appearing at the input whether the set is switched on or off. It is designed to withstand voltages of up to 30V r.m.s. without any of the transistors in the receiver chain being damaged and is achieved by the diodes 1D1 and 1D2 shunting the input to the receiver; these have a knee voltage of about 350mV which restricts the receiver input voltage level.

60. A section of the range switch designated S1C4 on the main circuit diagram provides a screen between sections of the high/low band switch in the input of the amplifier from those in the output stages of the amplifier.

61. Each section of the main gang capacitor 28C1 has a trimmer and temperature compensating capacitor in parallel with it, these are carried on a trimmer board module 1C.

First local oscillator and buffer amplifier
(Fig 5)

62. This circuit is carried on printed boards number 3 and 4.

63. The oscillator (3TR1) is in a crystal controlled Clapp circuit and the values of the feedback capacitor network 3C2 and 4C4 and the h.t. voltage have been chosen to give optimum performance over the frequency range 3-9MHz. The oscillation frequency is controlled by one of the twelve crystals 4XL1-4XL12, which cover the range from 3.450MHz-8.950MHz in 500kHz steps, the appropriate one being switched into circuit by the RANGE MC/S switch S1. The inductances 4L1-4L12 in series with the crystals ensure primarily that the circuit reactances are correct for oscillation to take place; they can also correct the crystal frequencies although this is a secondary effect. A high degree of accuracy in these crystals is not essential as small errors are taken up in the calibration procedure.

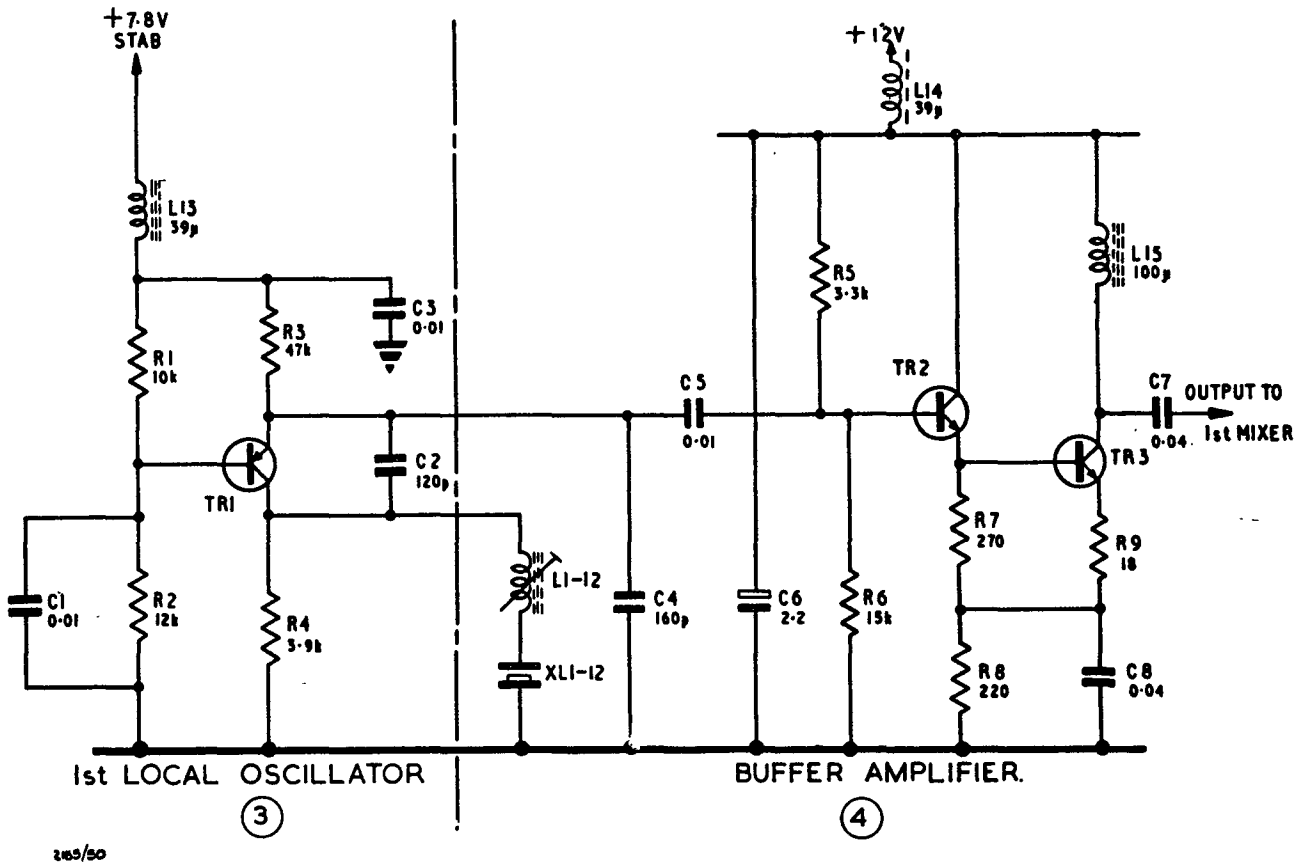

Fig 5 - First local oscillator and buffer amplifier, simplified circuit

64. The first mixer requires an oscillator voltage in excess of 1V to drive it, and in order to achieve this, the necessary power gain is provided by the buffer amplifier 4TR2 and 4TR3. This amplifier also provides the necessary impedance matching to the mixer stage and buffers the oscillator from the signal voltages in the mixer.

65. The amplifier is a conventional two stage d.c. coupled amplifier with 4TR2 connected as an emitter follower. D.C. stabilization is provided by 4R5 and 4R6 to the base of 4TR2 and by the common emitter resistor 4R8.

First mixer
(Fig 2534)

66. This circuit is carried on printed board number 2.

67. The first mixer is a double balanced mixer, which excludes from the output both oscillator and signal frequencies. This circuit is similar to the balanced modulator which is fully described in Tels A 151. The balance is achieved by accurately centre tapping the input and output transformers 2T1 and 2T2. The mixing diodes 2D1, 2D2, 2D3 and 2D4 each has a biasing resistor in series (2R10-2R13) which lengthens the dynamic operating path of the diodes and minimizes cross modulation products produced in the mixing process.

68. The output of the mixer is fed into a 3dB attenuator 2R14, 2R15 and 2R16, which effectively presents a constant impedance to the input of the 1st i.f. amplifier, minimizes variations in the mixer impedance, and, by reflection through the mixer, presents a reasonably constant load to the output of the r.f. amplifier.

69. The output from the attenuator is connected to the first i.f. amplifier via a low pass filter 2L16, 2L11, 2C13, 2C14, 2C15 and coupling capacitor 2C16, which prevents the higher frequency mixing products from entering the remainder of the receiver.

70. The first local oscillator and first mixer boards comprise together with the master oscillator sensitivity switch (para 143) one assembly, which is mounted on a screening plate. This assembly fits into a cavity in the main casting, the screening plate acting as a cover; thus the assembly is very effectively screened. The final shunt capacitance of the filter is formed by 2C15 and 28C4. This splitting minimizes spurious radiations from the assembly.

First i.f. amplifier
(Fig 6)

71. This circuit is carried on printed board number 5.

72. The first i.f. amplifier consists of the three transistors 5TR4, 5TR5 and 5TR6, together with the input and output tuned circuits 5L6, 28C2A and 5L7, 28C2B. The amplifier is similar to that in the receiver r.f. amplifier (para 54-56).

73. The input and output tuned circuits are tapped to give input and output impedances of 680 Ω , the circuits are tuned by two sections of the three gang capacitor 28C2, the third section being used to tune the second local oscillator. This capacitor is driven by the CHANNEL kHz film scale and the amplifier tunes over the band 0.95-1.45MHz.

74. The amplifier has a.g.c. giving a range of approximately 15dB applied by the control diode 5D1 in a similar manner to that described for the r.f. amplifier (para 55).

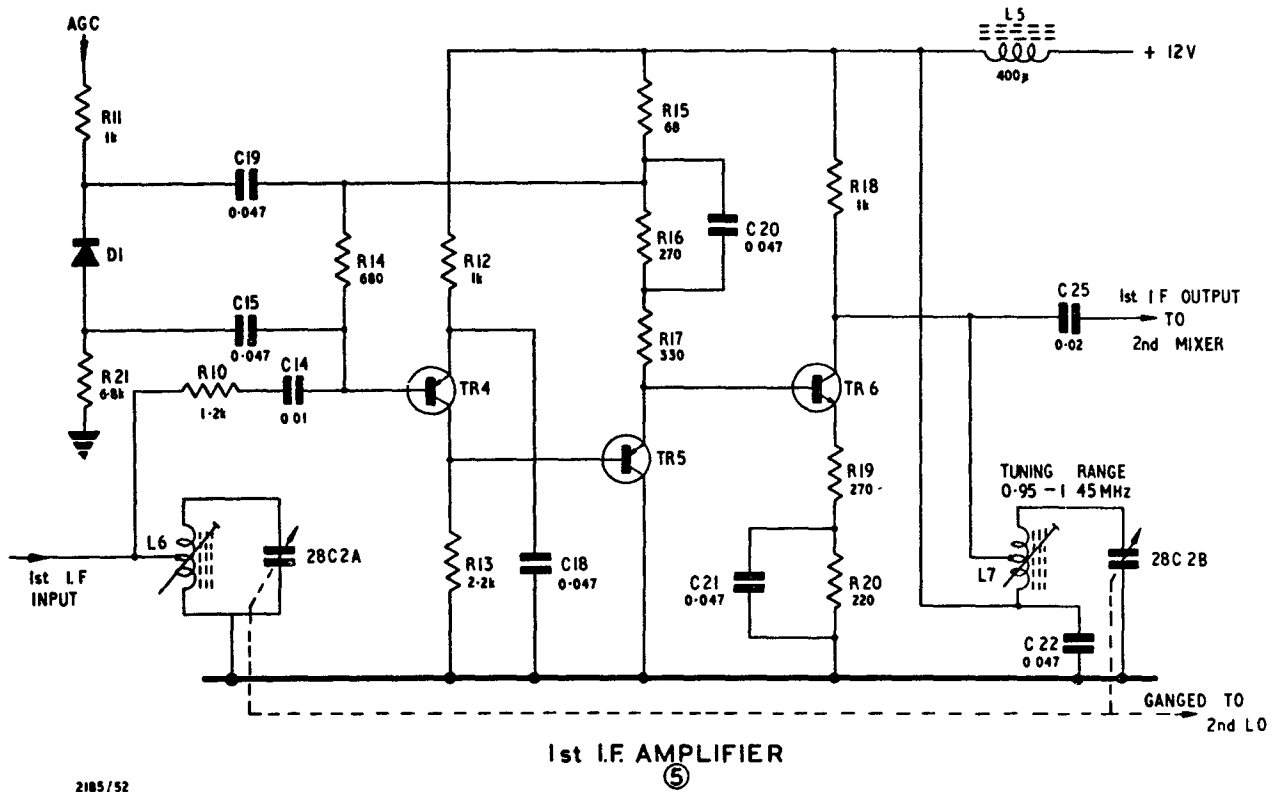

Fig 6 - First i.f. amplifier, simplified circuit

Second local oscillator
(Fig 7)

75. This stage is carried on printed wiring board number 5.

76. This variable frequency oscillator, the tuning capacitance of which is mechanically coupled to the CHANNEL kHz film scale, provides interpolation between the first local oscillator frequencies which are spaced at 500kHz intervals. The oscillator tunes over the band 1.405-1.905MHz, the tuning capacitor 28C2C being one section of 28C2, the other two sections of which tune the first i.f. amplifier.

77. The oscillator is transistor 5TR1 in a Clapp circuit, the main tuning elements of which are 5L2 and 28C2C with 5C6 the trimmer and 5C10 providing temperature compensation. The feedback network is provided by 5C4, 5C5 (temperature compensation) and 5C8, these are also effectively in series with the tuned circuit and also provide the padding necessary to correct the gang swing to the requisite ratio.

78. The output from the oscillator is fed via 5C9 to the buffer amplifier stages 5TR2 and 5TR3, these stages providing the necessary power gain and buffering to the second mixer stage.

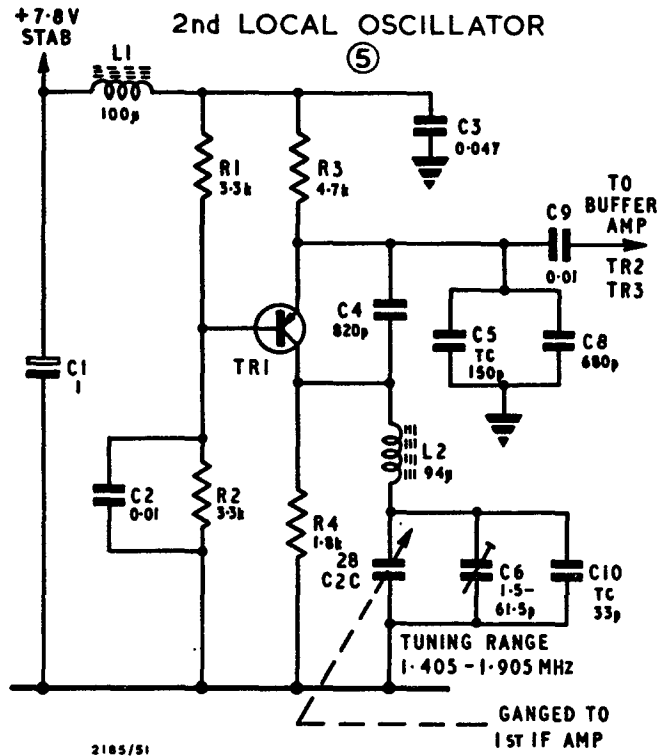

Fig 7 - Second local oscillator, simplified circuit

Second mixer
(Fig 8)

79. This stage is carried on printed wiring board number 6.

80. This mixer stage is similar to the first mixer (para 67). It is a double balanced mixer, balanced to the first i.f. input frequencies. The input to the mixer is a 3dB pad 6R1, 6R2 and 6R3 which presents a constant impedance to the output of the first i.f. amplifier.

81. The output from the mixer is fed via 6C6 to the amplifier 6TR1 which provides some gain and at the same time provides a high source impedance to the second i.f. filter.

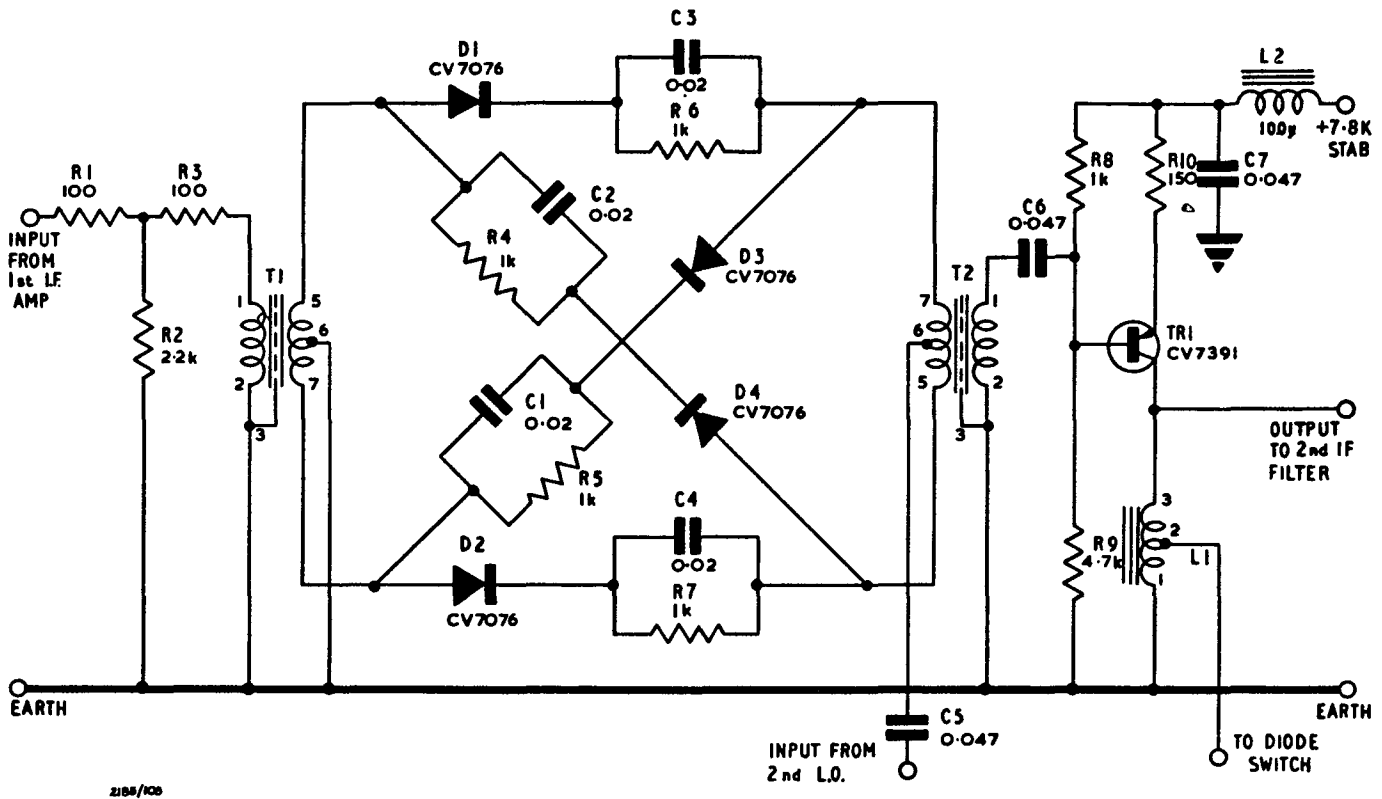

Fig 8 - Second mixer, simplified circuit

Second i.f. filter
(Fig 9)

82. This stage is carried on printed wiring board number 7.

83. The second i.f. filter 7LF1 is an electromechanical filter which has a passband of 6kHz at -6dB and a skirt rejection bandwidth of 20kHz at -60dB.

84. The filter is a mechanically resonant device which receives electrical energy, converts it into mechanical vibration and then reconverts the mechanical energy back into electrical energy at the output. It has a circuit Q of about 10,000.

85. The filter consists of four elements:

- a. The input transducer which converts the electrical input into mechanical vibrations.
- b. The metal discs which are mechanically resonant at 455kHz.
- c. The coupling rods which link the metal discs.
- d. The output transducer which converts the mechanical vibration into electrical energy.

86. The filter is contained in a cylindrical metal tube and is believed to be very stable and to have a high reliability; it cannot be repaired or adjusted.

87. The highly selective response of the filter can only be obtained if it terminates at both ends in a high impedance, to achieve this requirement it is fed from the capacitive network 7C1, 7C2 and feeds into the network 7C5 and 7C6. The trimmers 7C3 and 7C4 where applicable are used to tune the transducer coils in the input and output of the filter for minimum insertion loss from the filter. Fig 2542 refers.

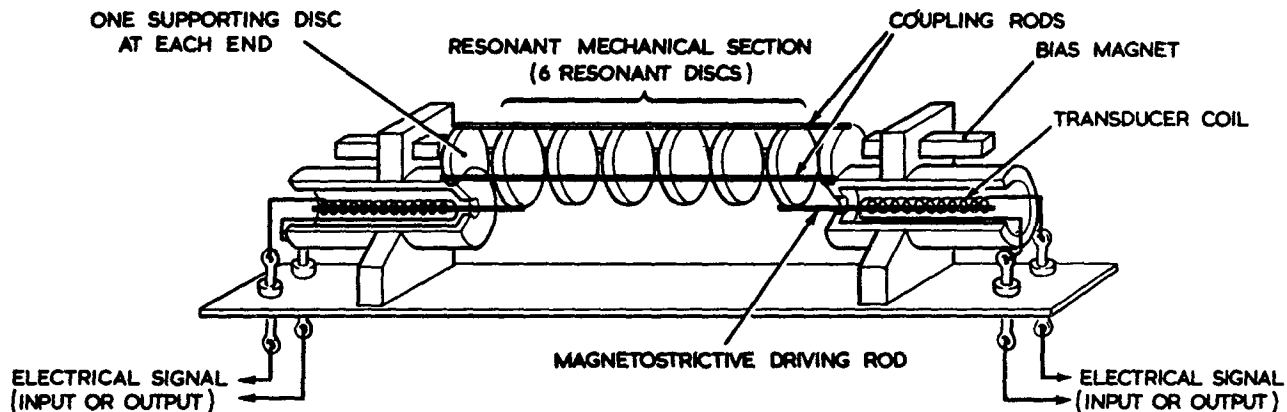

Fig 9 - Mechanical filter construction

Second i.f. amplifier
(Fig 10 and 2544)

88. This stage is carried on printed wiring board number 8.

89. The output from the filter stage is fed via 8C1 to the three r.c. coupled stages 8TR1, 8TR2 and 8TR3. The amplifier has a gain of approximately 75dB and a bandwidth of about 500kHz.

90. Negative feedback is applied to each stage to correct for variations in transistor characteristics and to improve the dynamic operating range. The unbypassed emitter resistors 8R4, 8R11 and 8R17 provide the necessary feedback.

91. The first two stages are a.g.c. controlled. The control takes the form of diodes 8D1 and 8D2 which, via capacitors 8C4 and 8C7, are effectively in shunt with the collector loads 8R3 and 8R10. The diodes are switched on by the a.g.c. voltage, the amount of shunting applied being proportional to the forward resistance of the diodes due to the a.g.c. voltage.

92. The collector load of the final stage consists of the tuned circuit 8L1 and 8C9, which fulfills the following functions:

- a. Provides rejection of unwanted frequencies.
- b. Provides the necessary impedance matching between the collector and the following stages.

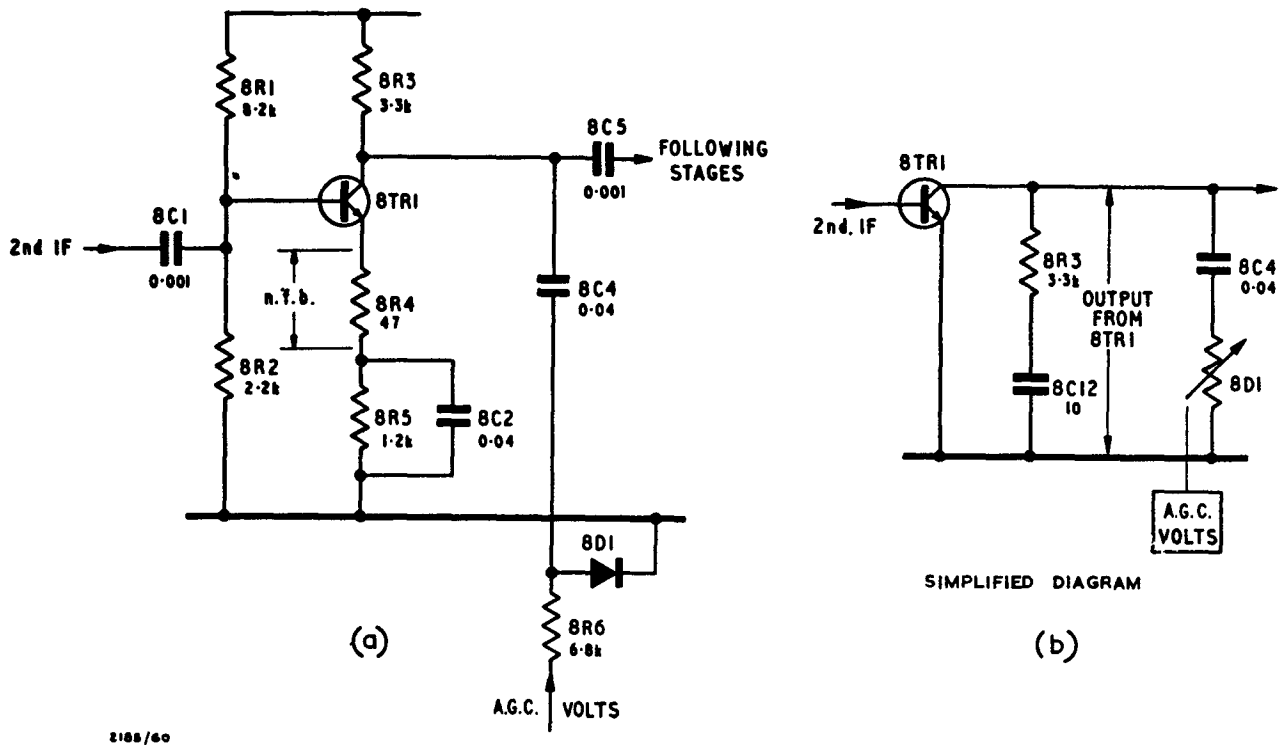

Fig 10 - Second i.f. amplifier, a.g.c., simplified circuit

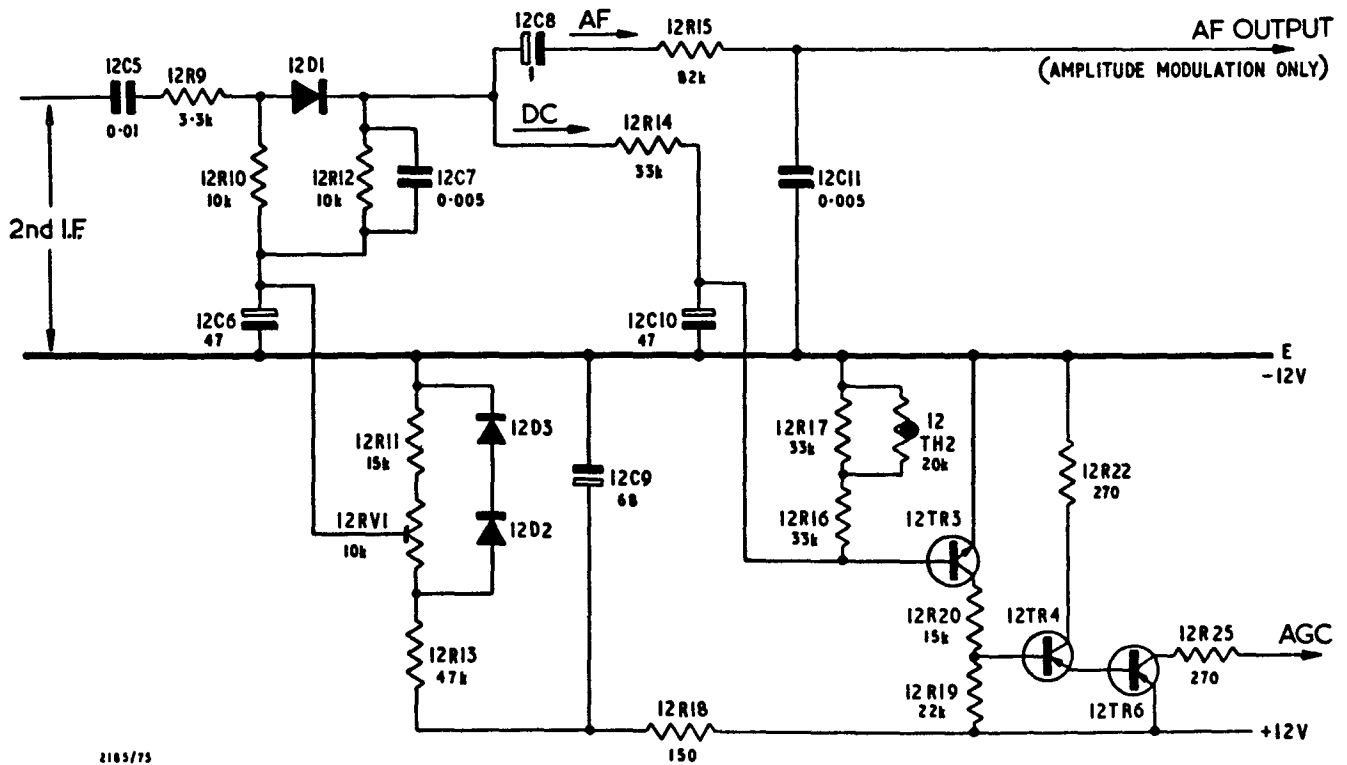

Fig 11 - A.M. detector and a.g.c. detector/amplifier, circuit diagram

A.M. and a.g.c. detector and a.g.c. amplifier
(Fig 11)

93. These stages are carried on printed wiring board number 12.

94. The output from the second i.f. amplifier is fed to 12D1 via 12C5, 12R9, 12R10 and 12C6; 12C5 provides d.c. blocking, 12R9 and 12R10 increases the impedance presented to the second i.f. amplifier by the detector.

95. When amplitude modulation is in use the modulated second i.f. signal is demodulated by 12D1 together with its load resistor and capacitor 12R12 and 12C7, the resultant a.f. signal being fed by 12C8 and 12R15 to the audio stages; 12C11 provides r.f. decoupling.

96. The second i.f. on either amplitude or phase modulation is rectified by 12D1 and the d.c. component which results, after a.f. decoupling by 12C6, 12C10 and 12R14, is fed to the base of 12TR3.

97. The diode 12D1 is given a threshold level by the bias chain 12R13, 12RV1 and 12R11, 12RV1 being set so that a.g.c. action commences with a second i.f. input of 0.8V; this threshold voltage chain together with 12R16, 12R17 and 12TH2 also provides the bias for 12TR3.

98. The a.g.c. amplifier is provided by the d.c. coupled amplifier 12TR3, 12TR4 and 12TR6, the output from this amplifier being at low impedance as the set employs a current-operated a.g.c. system.

99. Temperature compensation of the amplifier is provided by the diodes 12D2 and 12D3 and the thermistor 12TH2, all of which are in shunt with sections of the base biasing network of 12TR3.

Automatic and manual r.f. gain controls
(Fig 12)

100. Referring to Fig 12, it will be seen that in the first five positions of the system switch 28S3 the output of the a.g.c. amplifier (para 98) is applied to the receiver r.f. amplifier and the first and second i.f. amplifiers controlling the gain as required; para 55 and 74 describe this action. However, on transmit and TUNE RF, additional a.g.c. is required to reduce the receiver gain to the required level; this a.g.c. is obtained by means of 7R4 and 7D3 from the 12V transmit line and effects a reduction in receiver gain of approximately 40dB.

101. A similar reduction in receiver gain is required to prevent the generation of spurious responses during the CURSOR ADJ and CHANNEL ADJ stages of tuning, the necessary bias is obtained from the 12V calibrator supply via 22R18 and 22D2.

102. On c.w. operation the a.g.c. line is disconnected from these stages and they are manually controlled, the necessary bias being derived from the 9 step (10dB per step) switched potentiometer 27S2 which is connected between the receive 12V line and earth. The diode 27D2 ensures that the receiver a.g.c. line is held at the same standing potential as on ph.m. and a.m. when the set is switched to c.w. transmit.

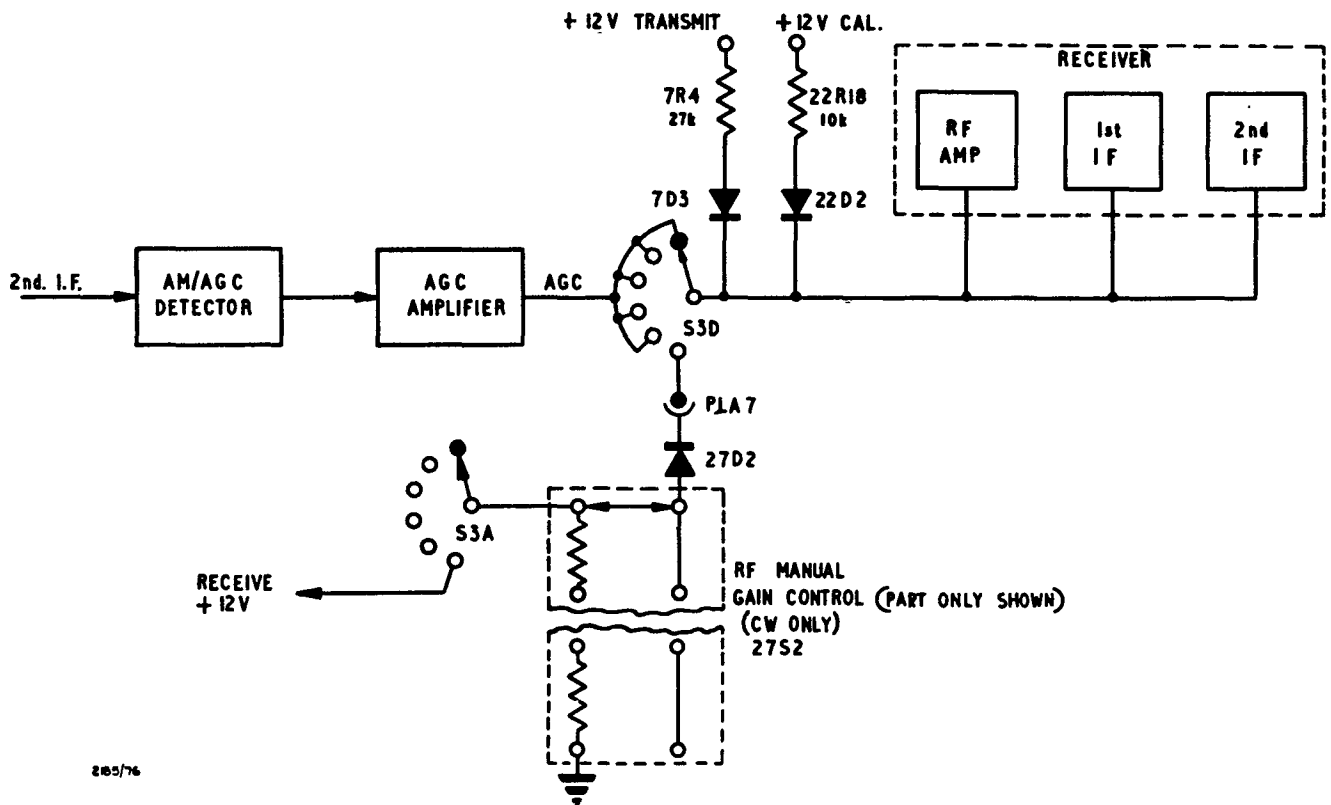

Fig 12 - Automatic and manual r.f. gain controls, simplified circuit

Limiter and discriminator
(Fig 13 and 14)

103. These stages are carried on printed wiring boards number 10 and 11.

104. The input from the second i.f. amplifier is fed via 10C1 to the first limiter stage 10TR1. On phase modulation the signal, after limiting, is applied to the discriminator which results in two outputs:

- a. The a.f. modulation which is fed on to the headphone amplifier.
- b. A d.c. output which is used to provide a.f.c. for the transmitter master oscillator.

105. On amplitude modulation and c.w., only the d.c. output is produced, and this is used to provide the a.f.c. to the transmitter.

106. The first two stages of the limiter 10TR1 and 10TR2 are d.c. coupled with a common feedback 10R5 for both collector circuits and the base bias circuit of 10TR1. The function of this circuit is to generate a square wave output whose amplitude is sensibly independent of the input level.

107. The output from these limiting stages is a.c. coupled via 10C4 to a further stage of amplification 10TR3 whose collector load consists of 10R9 and the primary of 10T1.

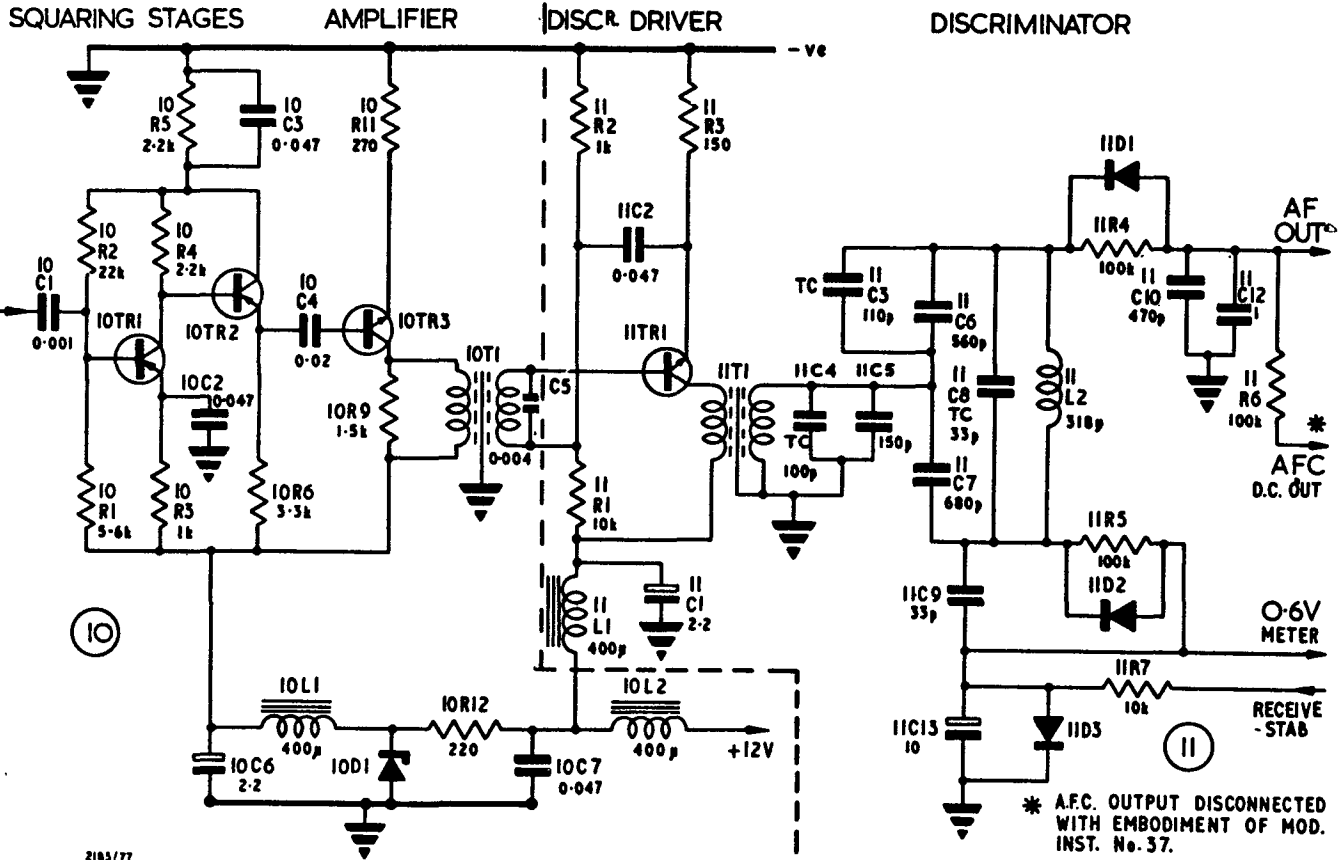

Fig 13 - Limiter and discriminator, circuit diagram

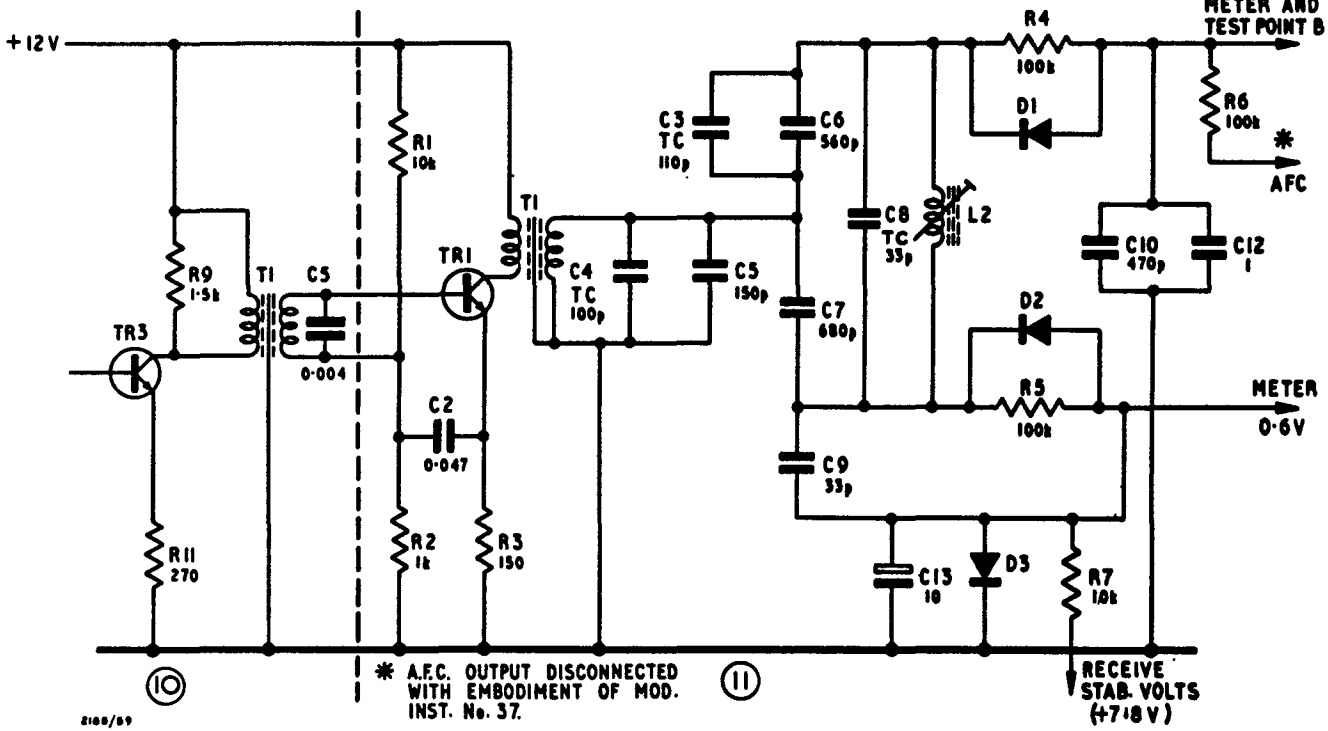

Fig 14 - Limiter and discriminator, simplified circuit

108. The secondary of 10T1 provides the signal to the discriminator drive stage 11TR1. This driver provides a high input voltage to the discriminator whose centre slope is of the order of 5V per kHz (open circuit) and yet has a bandwidth sufficient to cater for the a.f.c. capture range of the transmitter, ie $\pm 20\text{kHz}$ on the 4-8MHz band and $\pm 10\text{kHz}$ on the 2-4MHz band. The collector load of the driver transistor is the primary of 11T1 whose secondary has the correct impedance to drive the discriminator.

109. The discriminator is of the Bond type (see Tels A 013) whose main tuning components are 11C6, 11C7 and 11L2 with 11C9 as the 'offset' capacitor; the other capacitors in the tuned circuit 11C3 and 11C8 provide the necessary temperature compensation.

110. The capacitor 11C12 in conjunction with the output impedance of the discriminator provide the necessary slope correction circuit to the audio response which is necessary for phase modulation (see Tels A 013).

111. In the three calibration and r.f. tuning positions of the system switch 28S3 the meter is connected directly across the discriminator. The function of the biasing network 11D3 and 11R7 is described in the a.f.c. section (para 145).

112. The d.c. supply to the limiter section is stabilized by means of 10R12 and the Zener diode 10D1. The r.f. chokes 10L1 and 10L2, together with the decoupling capacitors 10C6 and 10C7, minimize the i.f. voltages which would otherwise appear in the d.c. supply and cause instability in the receiver.

Headphone amplifier
(Fig 15)

113. This stage is carried on printed wiring board number 13.

114. The amplifier consists of three stages and provides an output of approximately 10mW to the headphones.

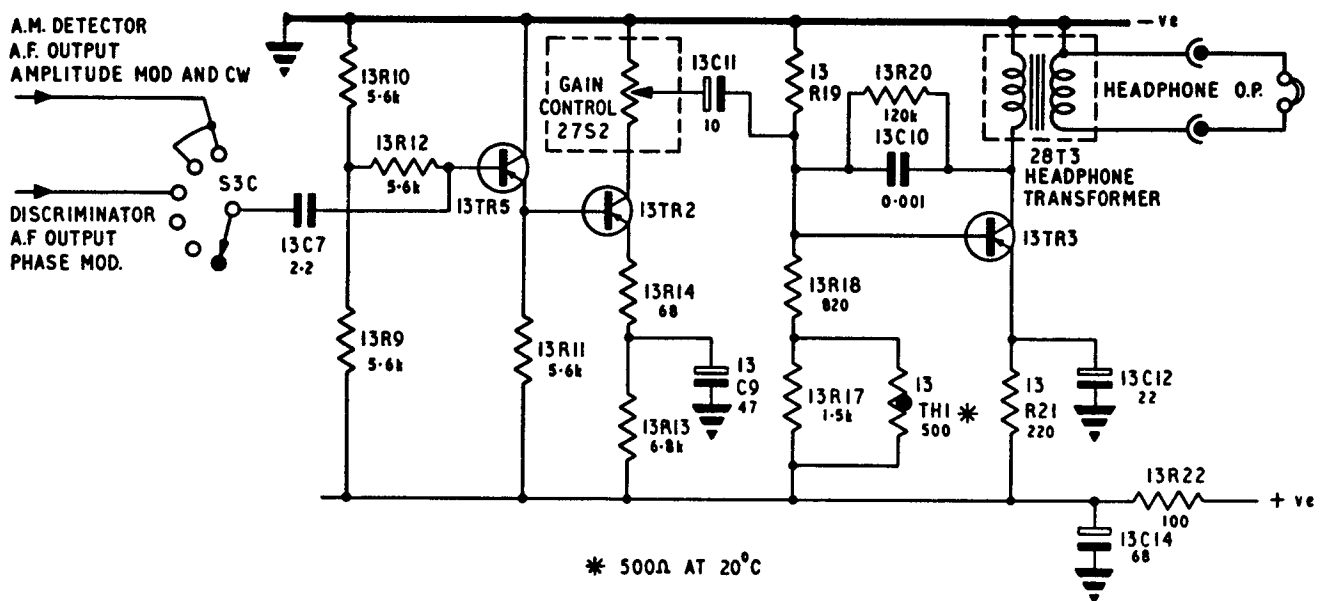

2105/70

Fig 15 - Headphone amplifier, simplified circuit

115. The a.f. input to the first stage 13TR5 is via 13C7 and the system switch 28S3C. On phase modulation the a.f. from the discriminator is connected and on a.m. and c.w. the a.f. output from the a.m. detector is used. The input impedance of the circuit on receive is approximately $7k\Omega$.

116. The first two stages 13TR5, 13TR2 are d.c. coupled thus avoiding the use of the large components needed with a.c. coupling. The collector load of 13TR2 is the a.f. gain control 27S2, which is a 10-position switched potentiometer. From the tap of the gain control the a.f. signals are fed via 13C11 to the base of the final a.f. stage 13TR3 whose collector load is the headphone transformer 28T3.

Beat frequency oscillator
(Fig 2546)

117. This stage is carried on printed wiring board number 9.

118. The oscillator 9TR1 is used in a Clapp circuit operating at a nominal frequency of 455kHz and which is variable by 3kHz about this centre frequency by the c.w. tone control 27C2 which is in parallel with 9C4 and 9C6.

119. The output from the oscillator is fed via 9C5 to the buffer amplifier 9TR2 and the output from this stage is fed via 9C9 to a tap on the inductance 8L1 in the second i.f. amplifier, the resultant beat note appearing as an audio tone in the a.m. detector and via the headphone amplifier in the headphones.

120. The d.c. supply to the board is via the system switch 28S3A and is only present in the c.w. position of the switch. The supply is partially stabilized by means of the Zener diode 9D1 and the resistors 9R11 and 9R10.

Receiver voltage stabilizer
(Fig 16)

121. This stage is carried on printed wiring board number 21.

122. The stage is included primarily to supply a stabilized 7.8V to the receiver first local oscillator although it is used to supply certain other circuits whose action is improved by the provision of a stabilized voltage.

123. The circuit is a conventional series stabilized one. The transistor 21TR4 being the series regulator whose forward resistance is controlled by the amplifier 21TR6, 21TR5 which compares the output voltage with a Zener diode reference 21D1.

124. The emitter of 21TR6 is connected to the reference diode 21D1 which is maintained at its Zener voltage by the bleed resistor 21R8. The base of 21TR6 is connected to a tap on the resistor chain 21R9, 21R10 which is connected between the stabilized voltage line (emitter of 21TR4) and earth, thus 21TR6 compares the stabilized voltage with the Zener reference.

125. To ensure good stabilization it is necessary to limit the current which flows in the collector of 21TR6 and therefore an additional stage of amplification is included (21TR5) which supplies the necessary base current to the regulator 21TR4.

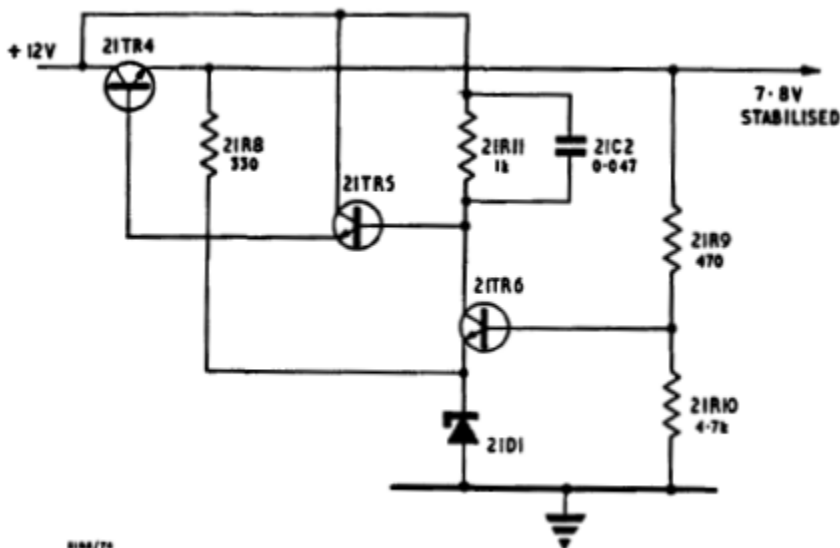

Fig 16 - Receiver voltage stabilizer, circuit diagram

Transmitter

Master oscillator - buffer amplifier (Fig 2559)

126. This stage is carried on printed wiring board number 18.

127. The master oscillator transistor is 18TR2 connected in a circuit partly Hartley and partly inductive coupling. The main tuned circuit consists of the collector winding of 18T1, and the gang capacitor 28C1A together with its trimmer 18C5 and temperature compensator 18C3. Between the high r.f. end of the collector winding and the base of 18TR2 is a diode 18D1 which prevents the oscillator bottoming and thus increases the stability of the oscillator.

128. The output of the oscillator taken from the emitter is capacitive coupled via 18C7 to the base of the buffer amplifier stage 18TR3, whose collector load consists of the broad band phase-splitting transformer 18T2.

129. The supplies for both these stages are derived from the transmitter stabilized supply (para 183). The bias for 18TR3 is derived from the chain 18R8, 18D2 and 18R7, the diode 18D2 provides the necessary temperature compensation.

130. The action of the reactance transistor 18TR1 and the a.f.c. circuits are described separately in para 141-150.

Driver, frequency doubler and power amplifier (Fig 17 and 2561)

131. These stages are carried on printed wiring board number 19.

132. On the low frequency tuning band, ie 2-4MHz it will be seen that the voltage developed across 18T2 (S1) is fed via 19D1 into the primary of 19T1 the driver transformer and the frequency appearing across the secondary of

19T1 will be the same as that in 18T2. The other secondary winding 18T2 (S2) is connected via the band change switch to a load resistor 19R1.

133. On the high frequency band, ie 4-8MHz the master oscillator is still running at 2-4MHz. It will be seen that the secondary winding 18T2 (S2) now connects via 19D2 to the primary winding of 19T1. Each half cycle in the primary of 18T2 will produce a pulse of current in the primary of 19T1 and the secondary output of 19T1 will be double that produced by the master oscillator.

134. The secondary of 19T1 is connected to the base of the driver transistor 19TR1 whose collector circuit comprises the primary of the phase splitting transformer 19T2.

135. An output at the driver frequency is fed via 19C1 to the receiver r.f. stage where after processing it provides the a.f.c. voltage to the reactance transistor 18TR1.

136. The base bias of the driver 19TR1 is derived via the chain 19D3, 19RV1, 19R3, 19R4 and 19D4, the diodes 19D3 and 19D4 provide the necessary temperature compensation. The adjustment of 19RV1 is associated with the operation of the p.a. stage (para 139).

137. The secondary of 19T2 is centre tapped and provides a phase split output to drive the push-pull p.a. transistors 19TR3 and 19TR4. These are operating in a common base mode to r.f. signals and common emitter for d.c. conditions. The collector load matching network is the centre tapped transformer 19T3 whose secondary is tuned by a section of the gang capacitor 28C1B, band changing being carried out by the band switch which selects the correct tap on the secondary together with the appropriate trimmers 19C8 and C10 or 19C10. The output to the antenna is also tapped into the secondary of 19T3.

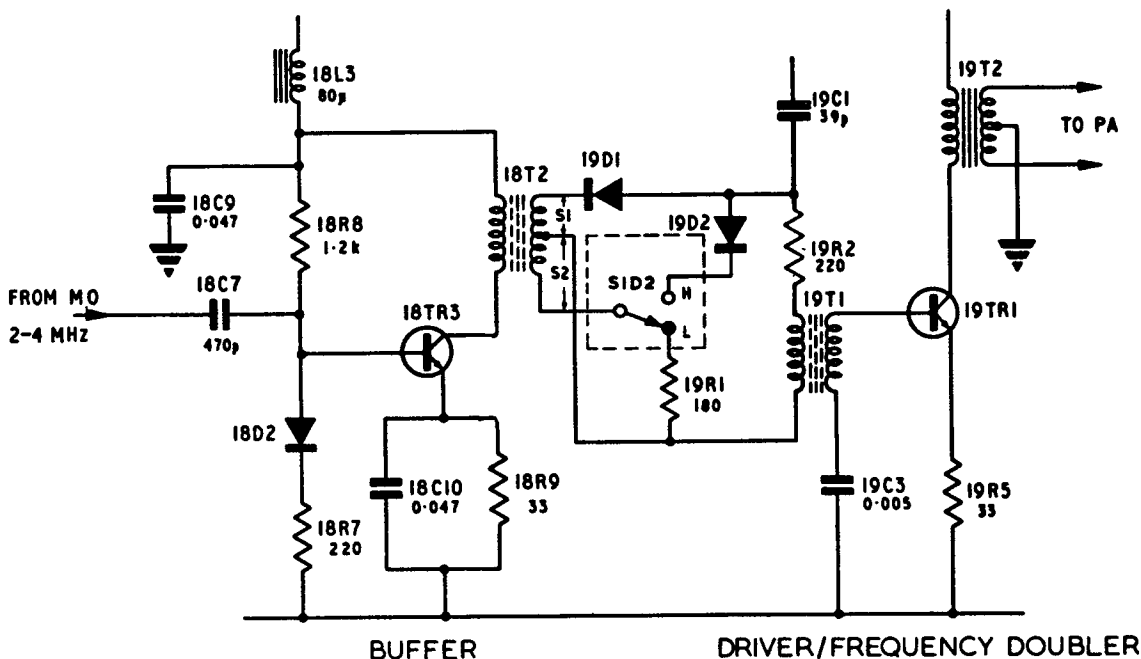

2188/48

Fig 17 - Driver, frequency doubler, simplified circuit

138. The p.a. stage is protected against mismatched load conditions. These conditions are given in para 139-140.

139. In the event of a short circuit being applied to the antenna a catastrophically high current could be drawn by the output transistors. To guard against this the transistor 19TR2 is used as a sensing device. The current being drawn by 19TR3 and 19TR4 flows through the resistor 19R7 to which the emitter of 19TR2 is connected. The collector of 19TR2 is connected via 19R6 to provide the base bias to the output transistors, the normal operating condition being set by 19RV1 which controls the base bias of 19TR2. If the output stage current rises the voltage drop across 19R7 will rise, this will cause the base bias to 19TR3 and 19TR4 to be adjusted so that their collector currents are maintained within safe limits.

140. In the event of an open circuit condition being present at the antenna which could result in damagingly high voltages the diode 19D5 will commence to conduct and, via 19R8, will provide a load to dissipate the excess voltage.

Reactance transistor and automatic frequency control
(Fig 18)

141. This stage is carried on printed wiring board number 18.

142. It will be seen that the master oscillator tuned circuit has connected in series with it a resistor 18R3 and d.c. blocking capacitor 18C4. The voltage developed across this resistor is proportionate to the circulating current of the tuned circuit and is in quadrature with the voltage across the inductor 18T1 primary. This voltage is applied via 18C2 to the base of the reactance transistor 18TR1, whose collector current is drawn through the upper part of the m.o. tuned circuit inductor, (Fig 18) this collector current which is 180° out of phase with the base current is also in quadrature with the inductance voltage and the sum effect is that 18TR1 appears as an inductance in parallel with the upper portion of the inductor.

143. If a modulating audio frequency is now applied from the microphone amplifier stages via 18C1 and 18L1 this will cause the collector current of 18TR1 to vary about a mean value, thus causing the m.o. frequency to vary about its nominal frequency by an amount depending upon the modulation voltage and at the rate of the modulating signal. To ensure that the deviation is maintained constant over the frequency band the modulating signal is shunted by the requisite resistance, the value of which is selected by a wafer of the RANGE MC/S switch 28S1.

144. A standing base bias of 0.6V is applied via 18L1 to 18TR1; this is derived from the chain 24RV1 and 24R1 which are connected between the receiver stabilized line and earth.

145. On transmit the transmitted signal is fed to the receiver and any difference between this frequency and the receiver frequency (discriminator centre point) will result in an output from the discriminator. This output after passing through a filter formed by the discriminator impedance (approximately $39k\Omega$) and the capacitor 11C12 is fed via 11R6, (29R1 after embodiment of Mod Inst No 37) and 18L1 to the base of 18TR1, this voltage being in such sense and amplitude that the resultant change in collector current of 18TR1 corrects the master oscillator frequency until it equals that of the discriminator centre frequency.

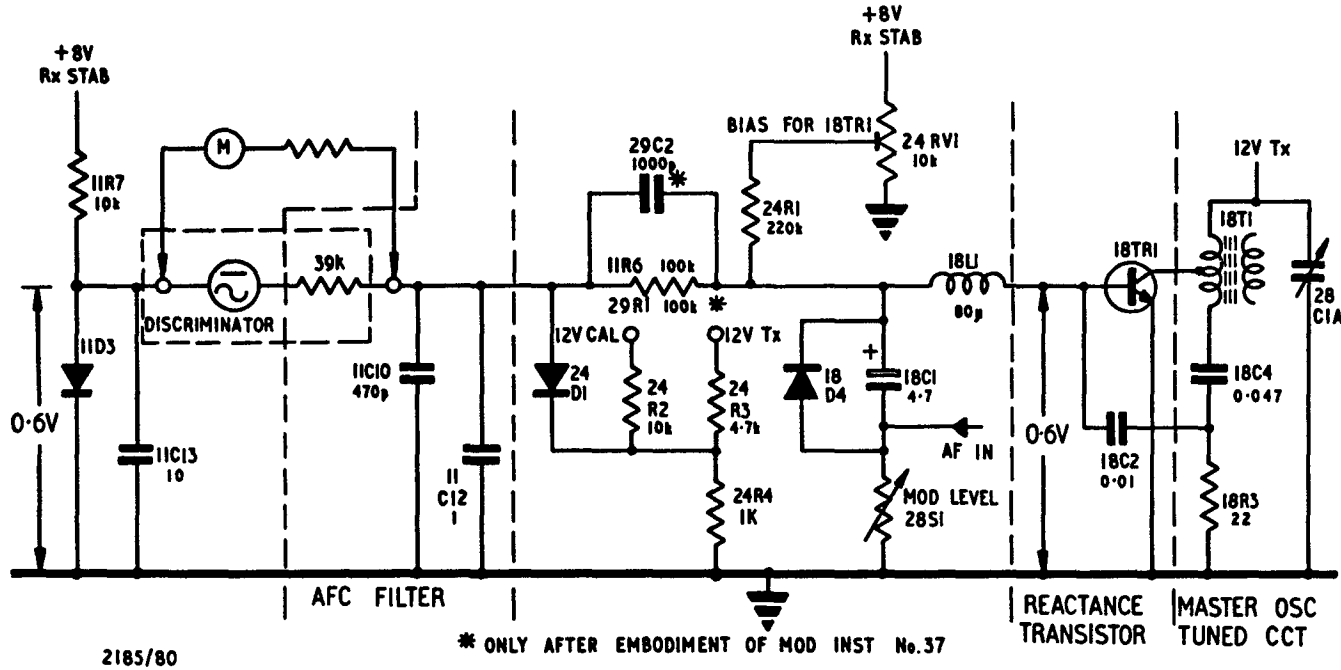

Fig 18 - Reactance transistor and a.f.c., simplified circuit

146. For tuning purposes the centre zero meter is connected directly across the discriminator, and it will be seen (Fig 18) that the bias for 18TR1 will have raised one side of the discriminator to 0.6V. To counteract this voltage and ensure that the meter reads zero when there is no discriminator output, a corresponding 0.6V is applied to the other side of the meter, this being provided by the chain 11R7 and 11D3 connected across the receiver stabilized supply. The diode 11D3 has been chosen to have similar temperature characteristics to 18TR1 and therefore over a very wide temperature range the meter will remain zeroed.

147. In order to obtain a wide capture range for the a.f.c. system it is necessary to bypass the second i.f. filter on transmit. To achieve this a diode switch 7D1 and 7D2 is included, connected so that upon switching to transmit the 12V transmit line turns them on to provide a resistive path between the tap on the second mixer output coil 6L1 and the second i.f. amplifier input coil 8L3; at the same time the input to the filter 7FL1 is connected to earth by the keying relay contact RLA2, and additional bias is applied via 7R4 and 7D3 to the a.g.c. line.

148. If the set is left off-tune on receive the a.f.c. line could be raised to $\pm 15V$ in the extreme case. If this were a negative voltage it could damage the tantalum capacitor 18C1 which is normally polarized by the 0.6V bias of 18TR1. To obviate this possibility the diode 18D4 is connected across 18C1.

149. In the event of the a.f.c. line being excessively positive on receive the capacitors 11C10, 11C12, 18C1 would charge up and on switching to transmit they would deliver a high voltage pulse to the reactance transistor 18TR1 and would probably drive the master oscillator so far off tune that it might lock on to a spurious response. To obviate this possibility the diode 24D1 through 24R4 keeps the a.f.c. line down to 0.6V. However to ensure efficient a.f.c. action a discriminator voltage greater than 0.6V is required, therefore on switching to transmit the diode 24D1 receives a bias

of about 2.1V from the chain 24R3 and 24R4 which are connected across the transmit 12V line and earth.

150. Similarly on the calibrate positions of the system switch the a.f.c. line could not (due to the action of 24D1) go sufficiently positive to give a full scale meter indication; to obviate this a bias voltage of 1.1V is applied to 24D1 from the chain 24R2 and 24R4 connected between the 12V calibrator supply line and earth.

Automatic frequency control delay
(Fig 19)

151. This stage is carried on printed board number 29.

152. It is only found in those equipments which would otherwise suffer from failure of the a.f.c. at certain frequencies. This failure, which occurs during the transition from receive to transmit, is attributed to spurious outputs from the discriminator taking control of the a.f.c. loop before the legitimate control signal from the m.o. can do so. The effect is to drive the m.o. frequency outside the capture range of the a.f.c. system.

153. On receive RLD/2 is not energised, and the discriminator output is clamped at 0.6V via 29RLD1 and 29D1. On switching to transmit RLD/2 is energised via 29TR1. However there is a delay in its operation due to the need for 29C1 to charge before 29TR1 can conduct fully.

154. The output of the discriminator, which on transmit is used to provide the a.f.c. voltage, therefore remains clamped at 0.6V until RLD/2 comes into operation.

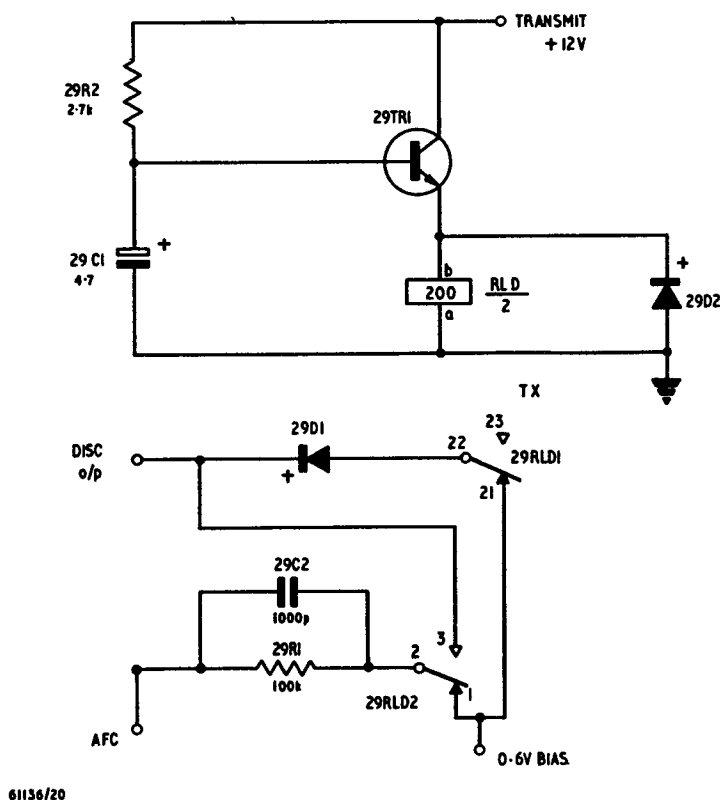

Fig 19 - A.F.C. delay circuit diagram

155. Hence any transients present in the receiver are prevented from producing a discriminator output, and thereby affecting the m.o. frequency during this delay period.

156. By the time the relay finally operates, the signal from the m.o. will have taken control of the discriminator. The discriminator output voltage can now pass to the a.f.c. line via 29RED and 29R1.

Phase modulation
 (Fig 20)

157. This stage is carried on printed wiring boards number 15, 16 and 18.

158. On phase modulation the microphone voltages are fed via the frequency shaping circuit 16C3, 16L1 and 16C4 which gives the top cut necessary for phase modulation. Following this low pass pre-emphasis is determined by 16C7, base cutting being carried out by the coupling and decoupling capacitors in the amplifier. The resistor 16R2 ensures that the microphone is correctly loaded. See Tels A 013 for description of phase modulation.

159. The microphone amplifier proper consists of the two r.c. coupled stages 15TR2 and 15TR3, current negative feedback being provided to these by means of the unbypassed limiting resistors 15R16 and 15R21. The a.m.c. control of this amplifier is described in para 171-177.

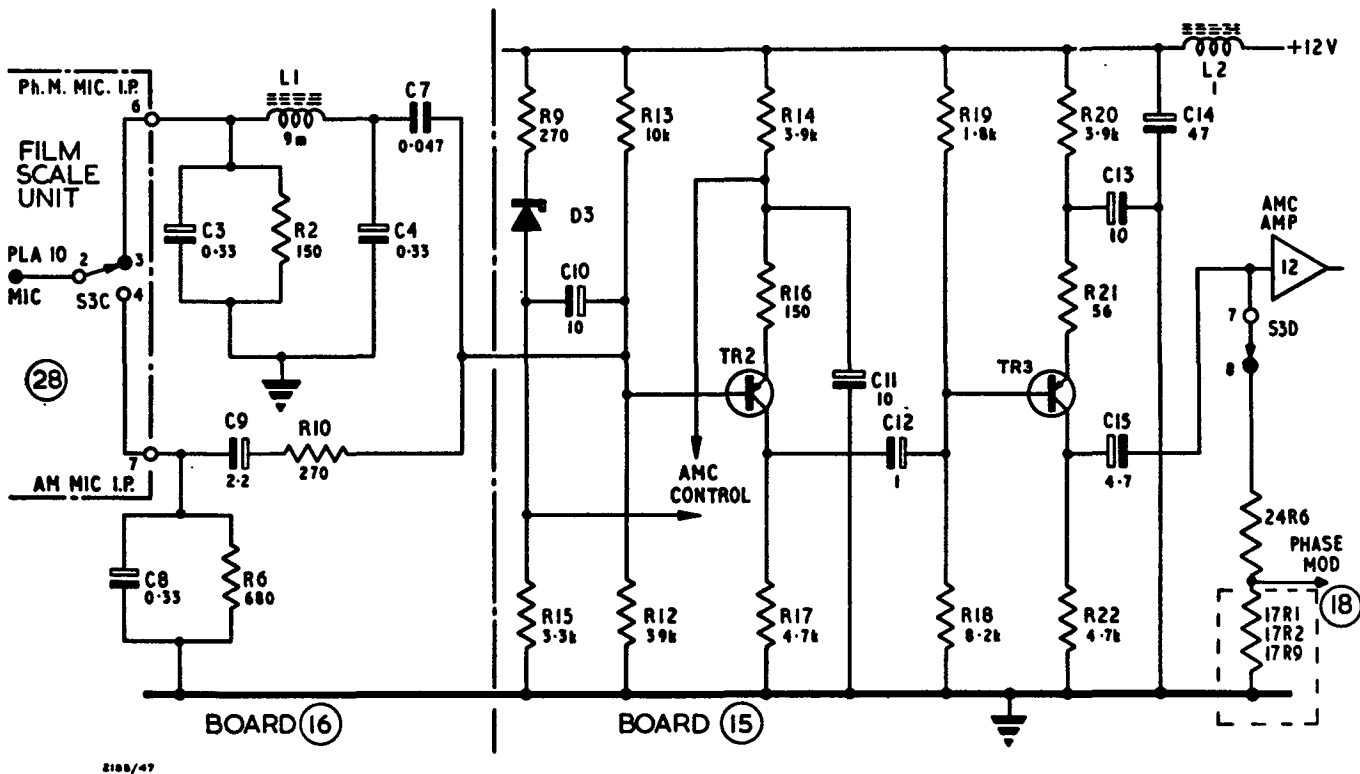

Fig 20 - Microphone amplifier, simplified circuit

160. The audio output from the amplifier is passed via 15C15 and 24R6 to the reactance transistor where phase (frequency) modulation takes place (para 141-144 and Tels A 013). The output from the amplifier is also shunted by a parallel resistance combination formed by 17R1 and one of the resistors 17R2-17R9, the appropriate combination being chosen by the RANGE MC/S switch S1, the value of this shunt resistor has been chosen to ensure that the deviation remains constant over the tuning band.

Amplitude modulation
(Fig 21)

161. This stage is carried on printed wiring board number 20.

162. The microphone input to the amplifier is via 16C9, (Fig 20) the response of the input circuit being flat over the band 300-3000Hz; above 3000Hz top cut is determined by 16R10 and 16C8, base cut being determined by the amplifier as described under phase modulation. The resistor 16R6 provides the correct loading to the microphone.

163. Amplification is now by 15TR2 and 15TR3 exactly as described for phase modulation. The output from 15C15 is on a.m. further amplified by the two stage amplifier 12TR1 and 12TR2 (Fig 2552). This consists of an emitter follower 12TR1 and r.c. coupled to it 12TR2 whose collector load is the primary of 28T2. Temperature compensation is provided for the base bias of 12TR2 by the thermistor 12TH1 in parallel with 12R4.

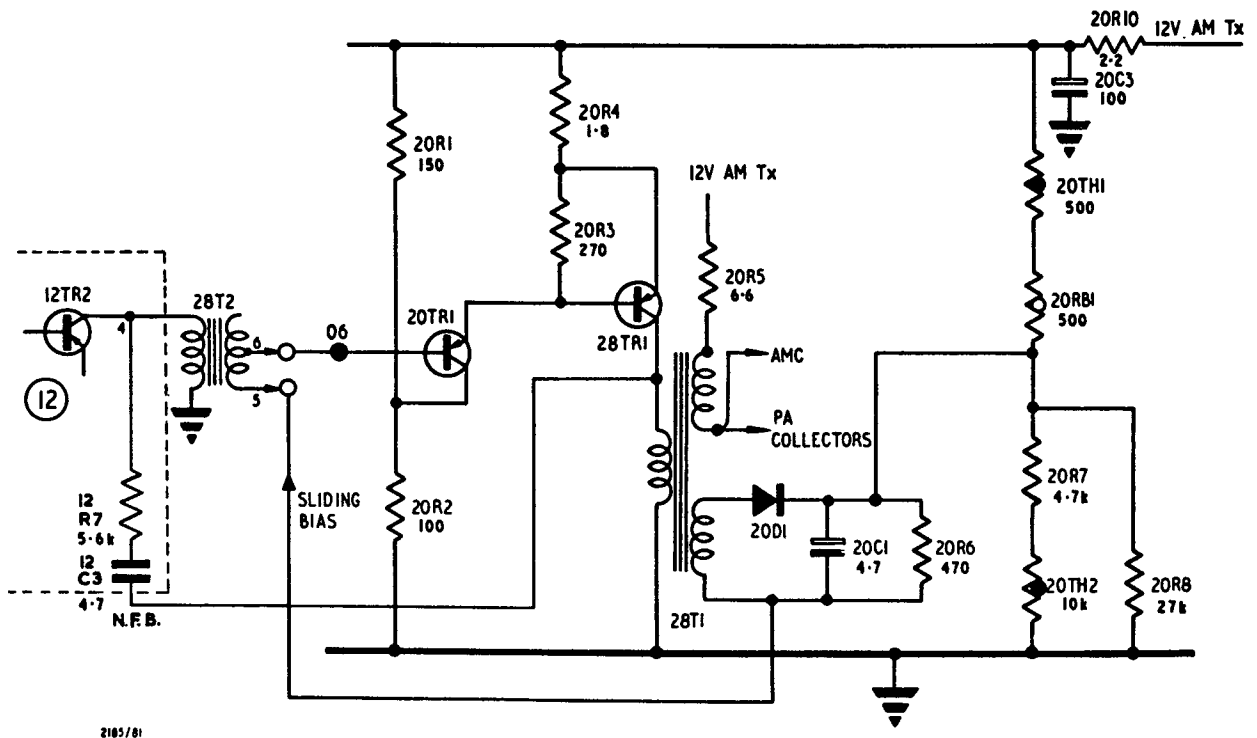

Fig 21 - Amplitude modulation, simplified circuit

164. Referring to Fig 21 it will be seen that the primary of 28T2 is the collector load of the audio amplifier 12TR2. Part of the secondary winding feeds the audio signal to the emitter follower 20TR1 which is d.c. coupled to the modulator 28TR1. The collector load of 28TR1 is the primary of the transformer 28T1. One secondary of this transformer carries the p.a. collector current and thus provides the amplitude modulation. The resistor 20R5 reduces the p.a. voltage to about 9V thus preventing over-volting of the transistors during any cycle of modulation. The modulator amplifier 20TR1 and 28TR1 is a sliding bias amplifier, the power handling capability of 28TR1 being adjusted according to the power requirement. This reduces the current drain when the amplifier is quiescent, typical figures being from 175mA quiescent to 550mA fully driven. Negative feedback is also provided by the feed 12R7 and 12C3.

165. Bias control is obtained by rectifying (20D1) the output of the other secondary of 28T1, the voltage being developed across the resistor 20R6. Static bias for 20TR1 is produced by the tap on the network 20TH1, 20RB1, 20R7, 20TH2 and 20R8 applied to the base of 20TR1 via 20R6, any voltage developed across 20R6 being in opposition to the static bias. The network ensures that the modulator is fully temperature compensated. The a.m.c. circuitry is dealt with in para 171-177.

Sidetone

166. On phase modulation the transmitter signal which has passed through the receiver is demodulated in the discriminator and is then fed to the headphone amplifier exactly as on receive, in this way true sidetone is provided.

167. On amplitude modulation an audio signal is fed from the microphone amplifier output to the headphone amplifier 13TR5 via 13R8 and 13C7. The sidetone heard in the headphones is 'false', ie not derived by demodulation of the transmitted signal.

168. In order that the sidetone level shall be of a comfortable level the gain of the headphone amplifier is reduced by some 10dB on transmit. This is achieved by shunting the audio input to the headphone amplifier by 13C6 and 13R16 the diode 13D2 providing the switching, conducting when the 12V transmit voltage is applied to it.

169. On c.w. an audio tone is generated by the sidetone oscillator 13TR1 whenever the keying relay R1B operates, the output from the sidetone oscillator being fed via 13C5 to the last stage of the headphone amplifier 13TR3.

170. The oscillator 13TR1 operates as an r.c. oscillator at approximately 1000Hz, the frequency being set by the twin-tee network in the collector 13R4, 13R5, 13C2 and 13C4, 13C3 and 13R6. The oscillator receives its 12V transmit supply from the delay relay circuit, and the keying is provided by an earth applied to the base of 13TR1 via keying relay contact R1B1 and 13C1.

Automatic modulation control (Fig 22)

171. This stage is carried on printed wiring boards number 15 and 16.

172. Referring to Fig 22 it will be seen that the main a.m.c. control of the microphone amplifier is effected by 15TR1, the action of this stage is common to both phase and amplitude modulation, the method by which the control

signals to this transistor are produced differ for phase and amplitude modulation and will be described later.

173. The control transistor is connected as a shunt to a.f. across the base-emitter of the first microphone amplifier 15TR2 and the audio input to 15TR2 will vary according to the base bias of 15TR1, at the same time 15TR1 draws its collector current through the emitter resistor of 15TR2 and as the collector current of 15TR1 increases it will tend to bias 15TR2 off and further reduce the gain of the stage.

174. In order to effect a rapid control of microphone gain it is necessary to maintain the emitter voltage of 15TR1 constant and this is achieved by the use of the Zener diode 15D3 and the resistor 15R9.

175. The control voltage to the base of 15TR1 is produced on phase modulation as follows. The output from the microphone amplifier is fed to the two stage amplifier 12TR1 and 12TR2 (para 163). This amplifier, which is used as a driver for amplitude modulation, is used for a.m.c. on phase modulation. The gain of this stage is increased on phase modulation by the insertion of the decoupling capacitor 12C4 on the emitter of 12TR2.

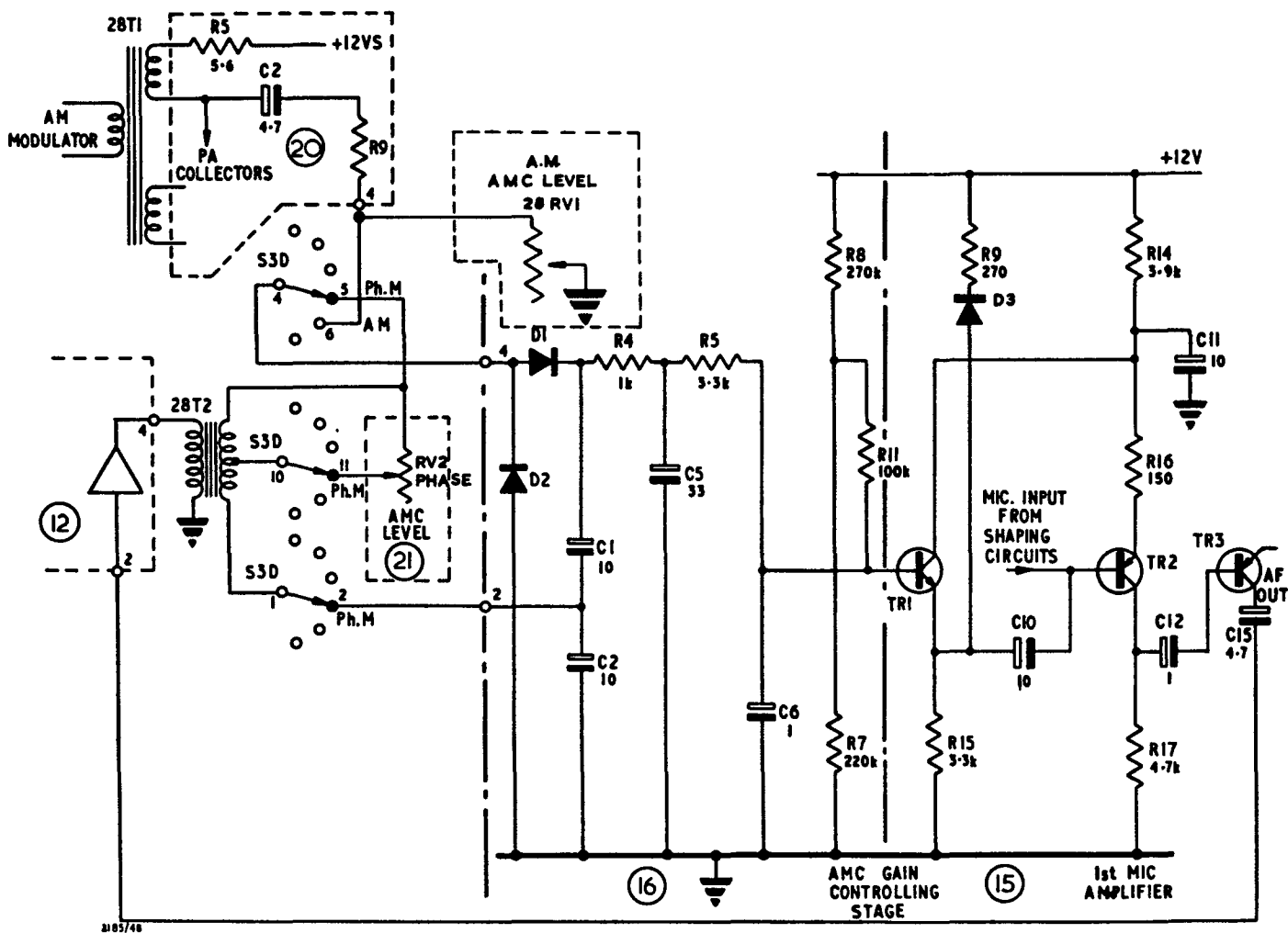

Fig 22 - Automatic modulation control, simplified circuit

176. The a.f. output from this amplifier appears in the secondary of 28T2 and is then applied to the rectifying-voltage doubling network 16D1, 16D2, 16C1 and 16C2 and the smoothing filter 16R4, 16R5, 16C5 and 16C6, the resultant a.m.c. control voltage being applied to the base of 15TR1. To allow the a.m.c. to be set to the correct level a preset potentiometer 21RV2 is connected across part of the secondary of 28T2.

177. On amplitude modulation, audio signals are taken from the secondary of the modulation transformer 28T1 via 20C2 and 20R9, this signal being shunted by the preset control 28RV1 to allow the correct a.m.c. level to be set. It is now applied to 16D1, 16C1 and 16C2 where half wave rectification takes place, the resultant voltage being smoothed and applied as control bias to 15TR1 in the same manner as for phase modulation.

Relay delay and transmit-receive switching
(Fig 23)

178. This stage is carried on printed wiring board number 13.

179. On c.w. it is necessary to maintain the a.f.c. loop between characters, otherwise there will be a slight chirp at the beginning of each character as the master oscillator is captured by the receiver via the a.f.c. system.

180. To avoid this a delay has been fitted to the relay 24RLA, contact RLA1 switches the transmitter supply, and contact RLA2 earths the input to the second i.f. filter.

181. The relay RLA is operated via transistor 13TR4, which conducts when its base, via 13R24 and 13D3, is connected to earth by a pressel switch or key. The relay then operates in its normal time and no apparent delay can be observed. When the key or pressel is released 13TR4 will continue to conduct until 13C15 charges via 13R25 and the winding of 28RLB, which takes approximately 0.8 seconds. The diode 13D3 ensures a rapid switch-on with maximum delay on switch-off (otherwise on switch-off 13R24 would be in parallel with 13R25).

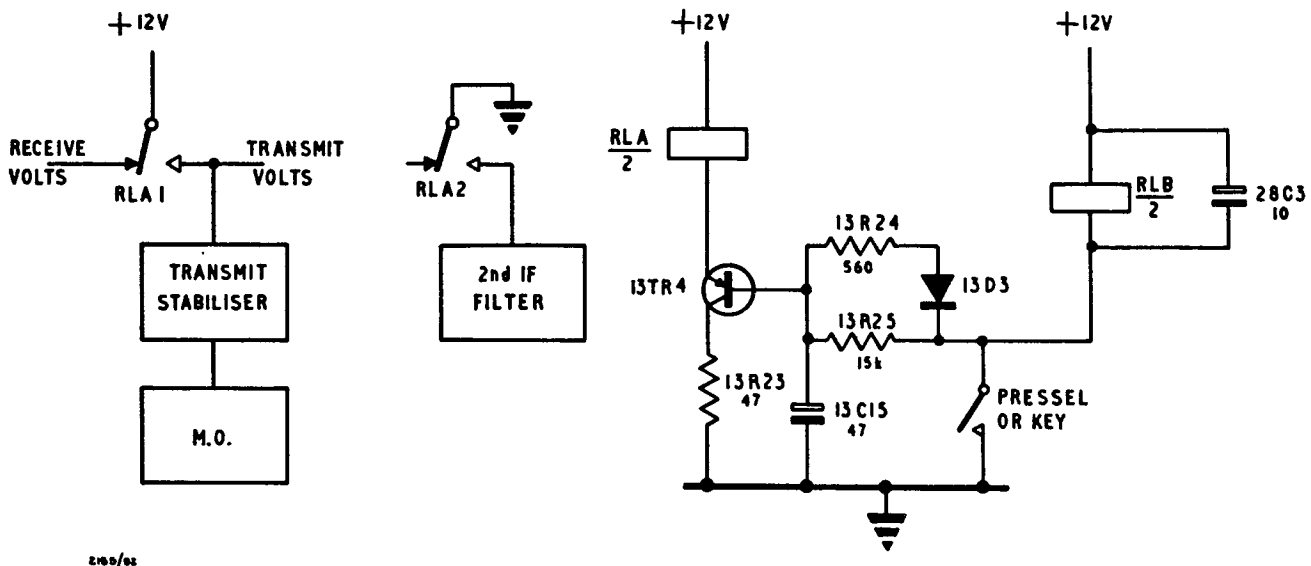

Fig 23 - Relay delay, simplified circuit

182. In addition to 24RLA an additional relay 28RLB is operated by the pressed or key, its contacts perform the following functions:

- a. RLB1 - On transmit c.w. - this provides an earth to operate the sidetone oscillator.
- b. RLB2 - Switches the antenna to either the receiver or transmitter.

Transmit stabilizer

183. The transmit stabilizer which is carried on printed wiring board number 25 functions in exactly the same manner as the receiver stabilizer described in para 122-125.

Calibrator

184. This is carried on a metal tray which covers the rear of the main casting. The circuitry is carried on three printed wiring boards numbers 22, 23a and 23b. Board number 22 carries the crystal oscillator and harmonic amplifier, whilst boards 23a and 23b, which are identical, are decade dividers.

Crystal oscillator

185. The oscillator 22TR1 is connected in a crystal controlled Pierce circuit. The frequency is determined by a highly stable 1MHz crystal 22XL1 with trimmer 22C2 connected in series.

186. The output from the oscillator is coupled via 22R7 to the base of 22TR2 which together with 22TR3 is connected in a Schmitt circuit (see Tels A 339). The output from this is developed across the collector load 22R11 and is in the form of square pulses which are fed to the first decade divider (board 23a).

Decade dividers

187. Two identical dividers are used in the set, the first, 23a, divides the 1MHz oscillator pulses down to 100kHz and the second, 23b, divides the 100kHz down to 10kHz.

188. The dividers consists of four binary stages in series with a gating circuit interposed between the first and second stages. This type of circuit is explained in Tels A 339.

Calibrator amplifier

189. The output from the first divider is connected directly to the amplifier 22TR4, whilst in the CHAN ADJ position of the system switch, S3C connects the output of the second divider (10kHz) to the amplifier. The output from the amplifier is connected via 22C9, S3A and RLB2 to the receiver input.

Calibrator stabilized supply and a.g.c.

190. The binary divider circuits require a stabilized supply of 6.8V, this is provided by the Zener diode 22D1, dropping resistor 22R17 and decoupling capacitors 22C10 and 22C11.

191. In order that the receiver shall not indicate spurious responses whilst it is being calibrated it is necessary to reduce the receiver gain. This is achieved by connecting the calibrator 12V supply via 22R18 and 22D2 to the receiver a.g.c. line.

Meter circuit
 (Fig 24)

192. In the three operate positions of the system switch the meter indicates the battery state. The meter is used as a comparator between the potential produced at a tap on a potentiometer chain 21R6, 21RV1 and 21R7 connected across the battery supply and the receiver stabilized voltage (7.8V). The meter bears a mark 'L' near the left-hand end point. The resistor 21RV1 is so adjusted that the pointer is in line with this mark when the input is 10V.

193. In the calibrate and TUNE RF positions of the system switch the meter is connected directly across the discriminator and biasing is provided to ensure the centre zero reading of the meter coincides with the centre tuning point of the discriminator. See para 146.

194. In order to avoid the meter being overloaded whilst tuning, a protection circuit consisting of the resistors 21R12 and 21R13 and the diodes 21D2 and 21D3 is connected across the meter.

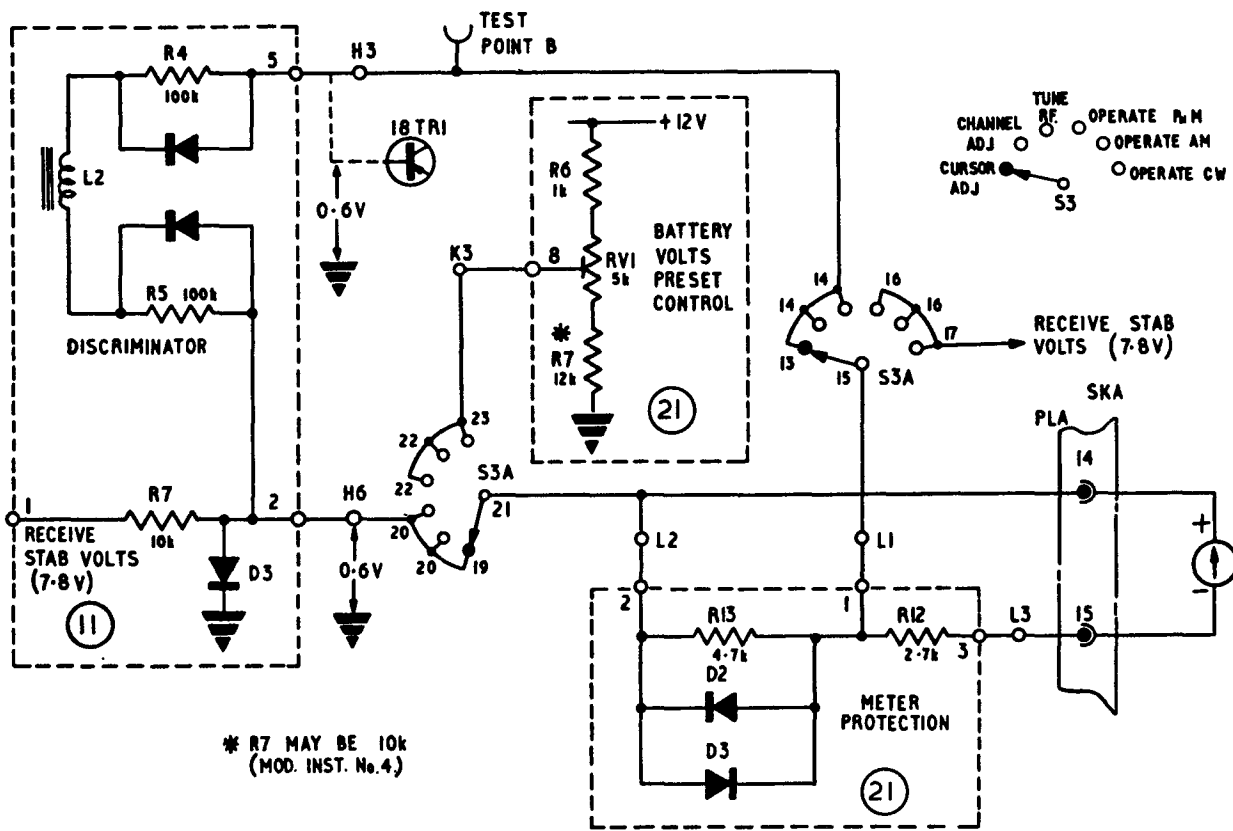

Fig 24 - Meter circuitry

Dial illumination

195. The supply oscillator is carried on printed wiring board number 26.

196. This is a single stage inductively coupled oscillator 26TR1, coupling being provided by 26T1. The secondary voltage of 26TR1 is rectified by 26D1 and 26D2, the resultant output voltage (approximately 85V) being applied to the neon illuminating lamps 27IP1-27IP4.

197. This oscillator is only operative in the three calibrating positions of the system switch, the supply voltage being switched via 28S3B.

Secondary batteries

198. The battery is made up of a number of nickel cadmium cells giving a nominal capacity of 12V, 2Ah. The whole is encapsulated in resin but each cell is fitted with a relief valve so that gas may escape if the cell is overcharged at any time. No maintenance or repairs are intended for these batteries except charging and the replacement of battery sockets. The batteries should be charged from a constant voltage source; facilities for charging are provided in the station by the voltage regulator unit and the hand generator unit.

199. A socket SKE is fitted to the projection at the base of the front panel. This is used for float charging the battery from the hand generator and for operating the equipment from an external 12V battery. A diode 27D1 is included in series with the positive lead to protect the equipment against polarity reversal.

Temperature compensation

200. There are two main types of temperature compensation provided in the TRA13, these are:

- a. To compensate tuned circuits for changes in component parameters with temperature.
- b. To ensure that transistor operation remains satisfactory over the operating temperature range of the set, ie -32°C to $+55^{\circ}\text{C}$.

201. The means adopted to comply with para 200.a. is to use suitable temperature compensating capacitors as part of the tuned circuit. These are marked TC on the circuit diagrams and in the parts list will be shown as having a nominal value plus a temperature factor, eg 100pF N750 or 47pF P100. N750 means that there will be a negative change in capacitance of 750 parts per million for a 1°C rise in temperature, similarly P100 would indicate an increase of capacitance of 100 parts per million per 1°C rise in temperature. It is essential that any of these components which are faulty be replaced by one of the part number specified, failure to do this will result in poor performance and will almost certainly prove an extremely difficult fault to diagnose.

202. The means taken to ensure correct transistor operation over the temperature range is normally associated with the base biasing circuits. Various methods are used, the most common being the use of temperature sensitive resistors, ie thermistors which have a negative temperature coefficient or silistors, positive temperature coefficient. The biasing

networks may contain either or both of these type of components in association with normal resistors.

203. Another method is to use a diode as a non-linear resistance in the base biasing chain, the diode normally chosen being one which has similar temperature characteristics to the transistor with which it is associated.

Remote control

General

204. The local remote-control circuitry is carried on printed wiring board number 21, the distant control being by means of a Control, Transmitter-Receiver, Remote (5820-99-949-6365) referred to hereafter in text as the Remote control unit (r.c.u.). In describing the circuit action, the local and distant ends will be described concurrently; detailed description of the r.c.u. will be found in para 212-219.

205. In order that instability due to r.f. picked up in the line and/or headset cords does not occur, decoupling capacitors are fitted, C8 and C9 in the r.c.u. and 27C4 in the TRA13.

Receive
 (Fig 25)

206. On receive the audio signals from the receiver phase modulation, a.m. or c.w. are fed via 21R3, RLC1, 21C1 to the LINE terminal, which is connected by up to half a mile of field cable to the r.c.u. The audio signal now passes via C7 through the primary of T1 returning via D1 and the EARTH line to the local receiver. The audio signal developed across T1 secondary 1 is amplified by the single stage a.f. amplifier TR4 whose collector load consists of the headphones connected via transformer T2.

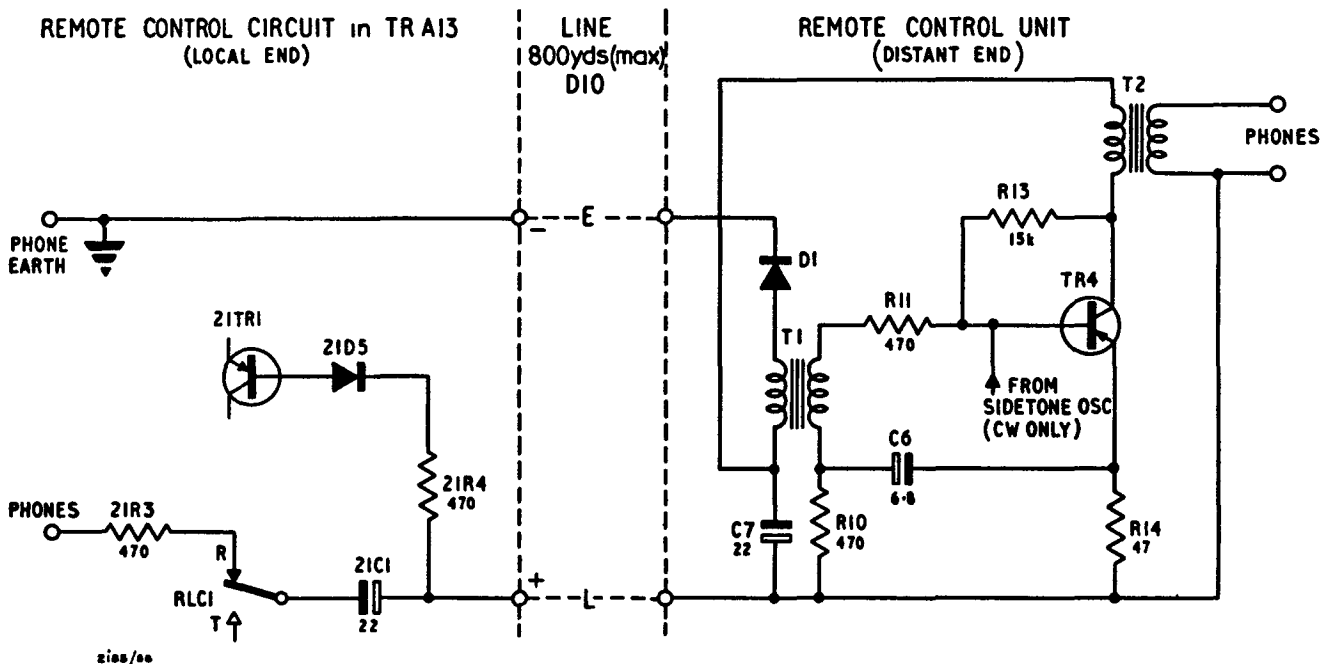

Fig 25 - Remote control, receive, simplified circuit

207. The d.c. supply for the transistors in the r.c.u. is provided from the TRA13 and fed down the line together with the audio, the current supplied for the receive condition being about 6mA. The diode D1 ensures that no damage occurs to the r.c.u. circuitry in the event of the lines being connected with reversed polarity.

Transmit RT
(Fig 26)

208. On transmit, assuming S1 (r.c.u.) is at RT, the action of closing the pressel has two effects. One contact causes a loop resistance of 270Ω (R1) to be connected across the line and this changes the bias of 21TR1 such that it conducts heavily and thus the collector load, relay RIC, operates. The contacts of this relay then perform the following operations:

- a. RIC1 - connects the audio path from the LINE terminal via 21C1 to the microphone amplifier in the TRA13.
- b. RIC2 - connects an earth to the transmit/receive relay in the TRA13 causing the set to change over to transmit.

209. The other pressel contact connects the microphone at the distant end to the base of the r.c.u. microphone amplifier TR1 whose collector load is secondary 2 of T1. The audio produced in the primary of T1 is now fed to line via C7 and thence via 21C1 and RIC1 to modulate the TRA13. At the same time audio, developed across secondary 1 of T1 and in a similar manner to the receive condition, will be heard in the earpiece of the r.c.u. as sidetone.

210. The diode 21D5 and thermistor 21TH1 provide the necessary temperature compensation. The diode 21D4 in the emitter of 21TR1 maintains the emitter at a constant voltage and ensures the fast positive action of relay RIC. The resistor 21R4 ensures that a.f. signals passing via 21C1 are not shunted by 21TR1 and its associated circuitry.

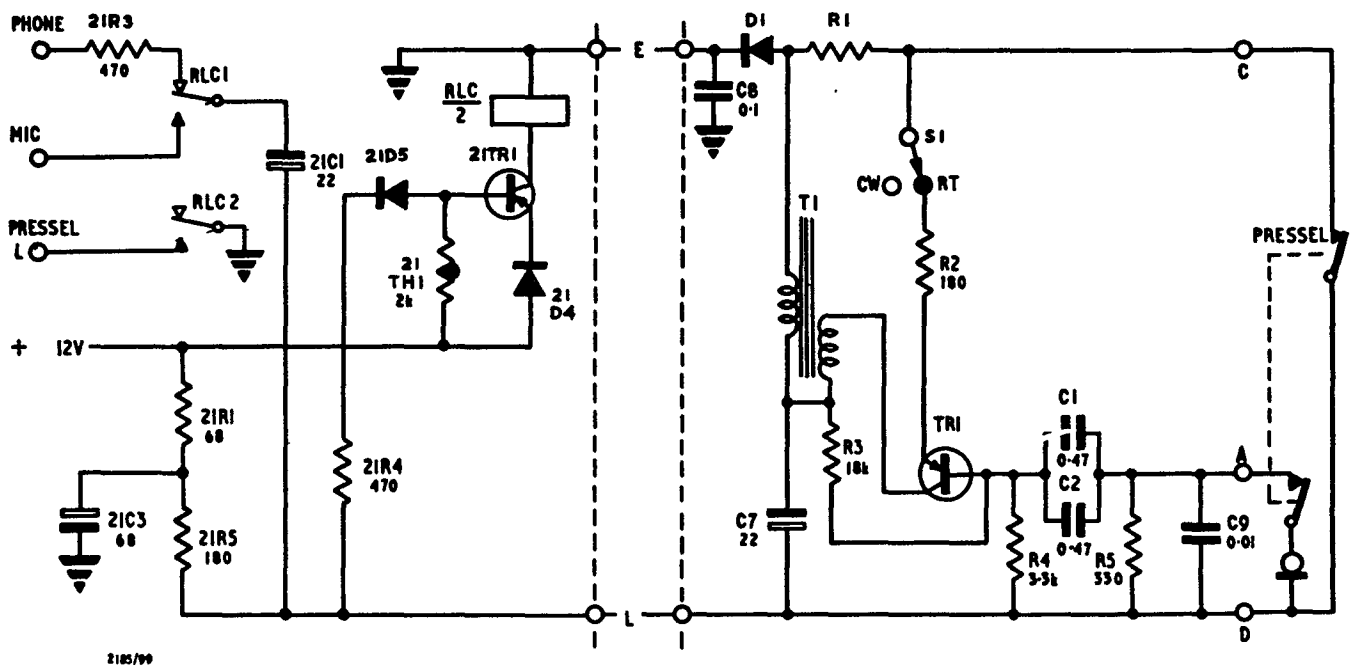

Fig 26 - Remote control, transmit RT, simplified circuit

C.W. transmit

211. When S1 (r.c.u.) is changed to its CW position, the c.w. sidetone oscillator TR2, TR3 is prepared for operation and when the key or pressel is closed the emitter circuits are completed and the oscillator produces a tone of approximately 1000Hz, this is fed via C5 to the headphone amplifier and thence to the phones where it is heard as sidetone. The pressel also loops the line with a 270Ω resistor causing the distant TRA13 to transmit in a similar manner to that described in transmit RT (para 208-210).

CONTROL, TRANSMITTER-RECEIVER, REMOTE (R.C.U.)

BRIEF TECHNICAL DESCRIPTION

General

212. The remote control unit allows the TRA13 to be operated from any distance up to 1/2 mile away. The unit is connected to the TRA13 by a field cable (D10), a pair of spring loaded terminals being provided on the set and the r.c.u. for this purpose. Two pattern 105, 6-way sockets are provided on the r.c.u. for connection of a headset or morse key.

213. In the receive condition audio signals pass down the line from the TRA13 to the unit where they are amplified before being fed into the head-gear. The d.c. current required in the receive condition is approximately 6mA, this is provided by the TRA13, the d.c. supply passing down the line as well as the audio signals.

214. In the transmit condition the microphone output signals are amplified before passing to the TRA13, sidetone at the r.c.u. is also provided. On c.w. operation the microphone amplifier is disconnected and no audio passes down the line. A local oscillator is switched on when the key is depressed to provide keying sidetone to the r.c.u. operator.

215. The current required by the unit for transmit operation is 20mA, this increase in current is sensed by the TRA13 and used to operate the transmit/receive relay in the TRA13.

216. The complete technical description is given in para 204-211 together with the operation of the remote control circuits of the TRA13.

Construction

217. The unit is contained in a sealed cast aluminium alloy box. Its physical characteristics are:

Length	-	6.1/2 in.
Height	-	3 in.
Width	-	3.3/4 in.
Weight	-	2 lb

218. A sealing bung is provided which carries a silica gel desiccator.

Controls

219. Fig 27 and Table 3 give details of the controls.

Table 3 - R.C.U. controls

Code	Function
SKA	Headset or key socket
SKB	Headset or key socket
TP1	Line terminal positive polarity
TP2	Line terminal negative polarity
S1	Selects RT or CW operation

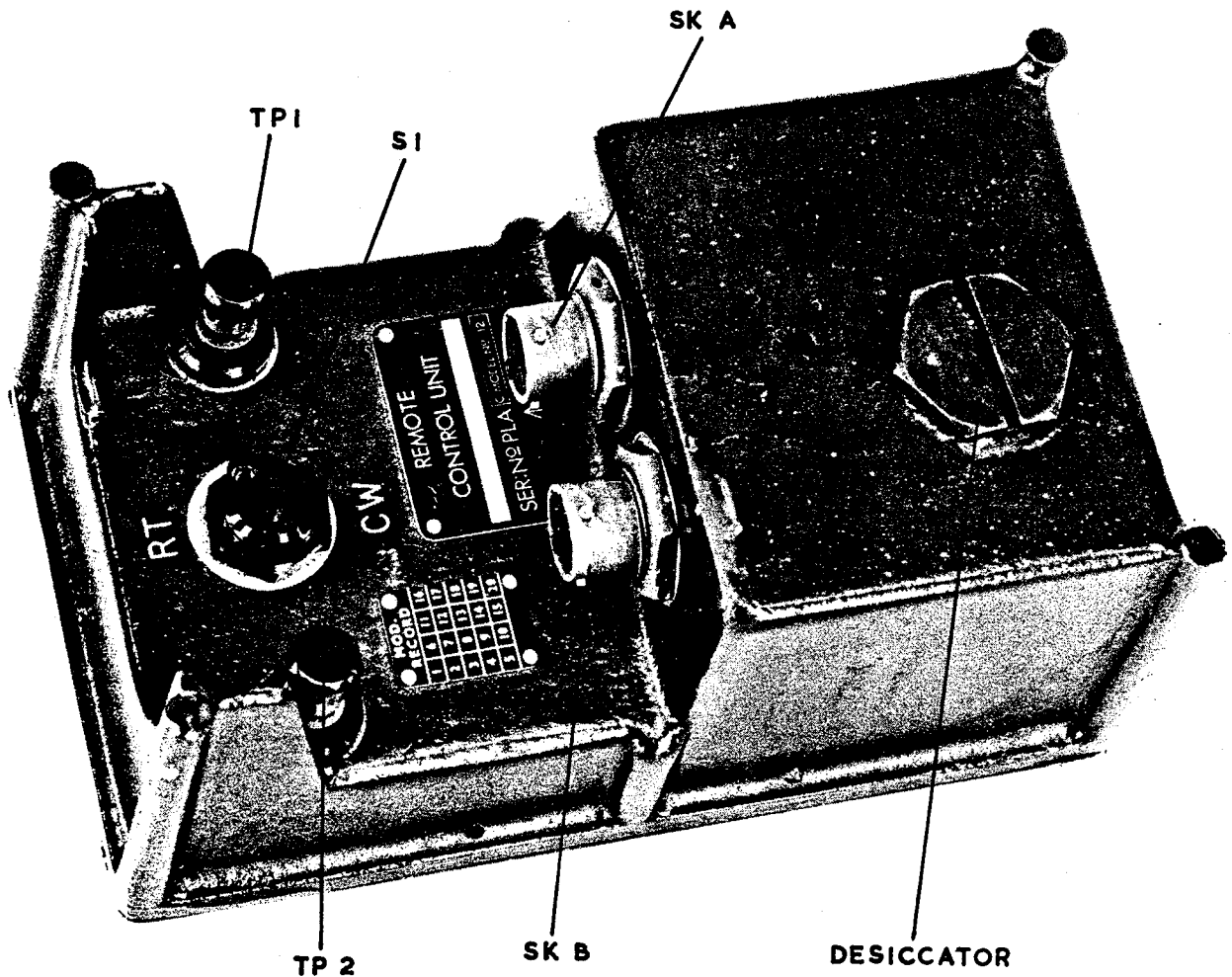

Fig 27 - R.C.U. controls

TUNER, R.F., ANTENNAE

BRIEF TECHNICAL DESCRIPTION

General

220. The tuner is an antenna tuning unit operating over the frequency range 2-8MHz and is designed to be used with the TRA13 alone or in conjunction with the Amplifier, r.f., No 12 (R.F.A. No 12).

221. The unit is provided with a four position range switch, a tuning control, a tuning meter, a coaxial r.f. input socket and outlets for the following:

- a. 8 ft whip antenna.
- b. 26 ft vertical wire antenna or calibrated end-fed antenna.
- c. Ground antenna or earth connection.

222. The metering circuit is arranged so that an output of 1.5W from the TRA13 will give approximately the same deflection as 16W when the Amplifier, r.f., No 12 is being used.

223. The unit is rated for continuous operation at any transmit/receive ratio at any temperature under high or low power conditions, except that at frequencies below 3MHz when the 8 ft whip or 26 ft wire antennae are in use on high power, transmission is restricted to 10 minutes in a 30 minute period.

Construction

224. The unit is contained in a fully sealed aluminium alloy case. A Hyclad gasket is used to achieve sealing between the front panel and the case. A silica gel desiccator is fitted to the sealing plug in the rear of the case.

225. The unit has the following physical characteristics:

Width	-	2.3/4 in.
Height	-	8.3/4 in.
Depth	-	5.1/2 in.
Weight	-	4 lb

226. The main tuning is achieved by means of a variable inductance, variation being achieved by ferrite slugs mounted on racks which are driven by a pinion mounted on the tuning shaft.

Controls

227. Fig 29 and Table 4 give details of the controls.

Table 4 - Tuner, r.f., controls

Item	Fig ref	Function
SK2	A	Socket for 8 ft whip antenna
TP1	J	For connection of end-fed or 26 ft vertical antenna. Connected to earth terminal (H) when using ground antenna
TP2	B	Ground antenna connection
TP3	H	For connection of counterpoise when used
Meter M1	C	Indicates antenna current
Tune control	D	Variable tuning, controlling variable inductances L1, L2, L3 and L4
RANGE S1	E	Range switch which selects appropriate inductance and capacitance
INPUT socket SK1	F	R.F. input from TRA13 or R.F.A. No 12 Mk 1 or 2

Table 4 - (cont)

Item	Fig ref	Function
LOCK	G	This is a mechanical lock which prevents item D from moving after tuning

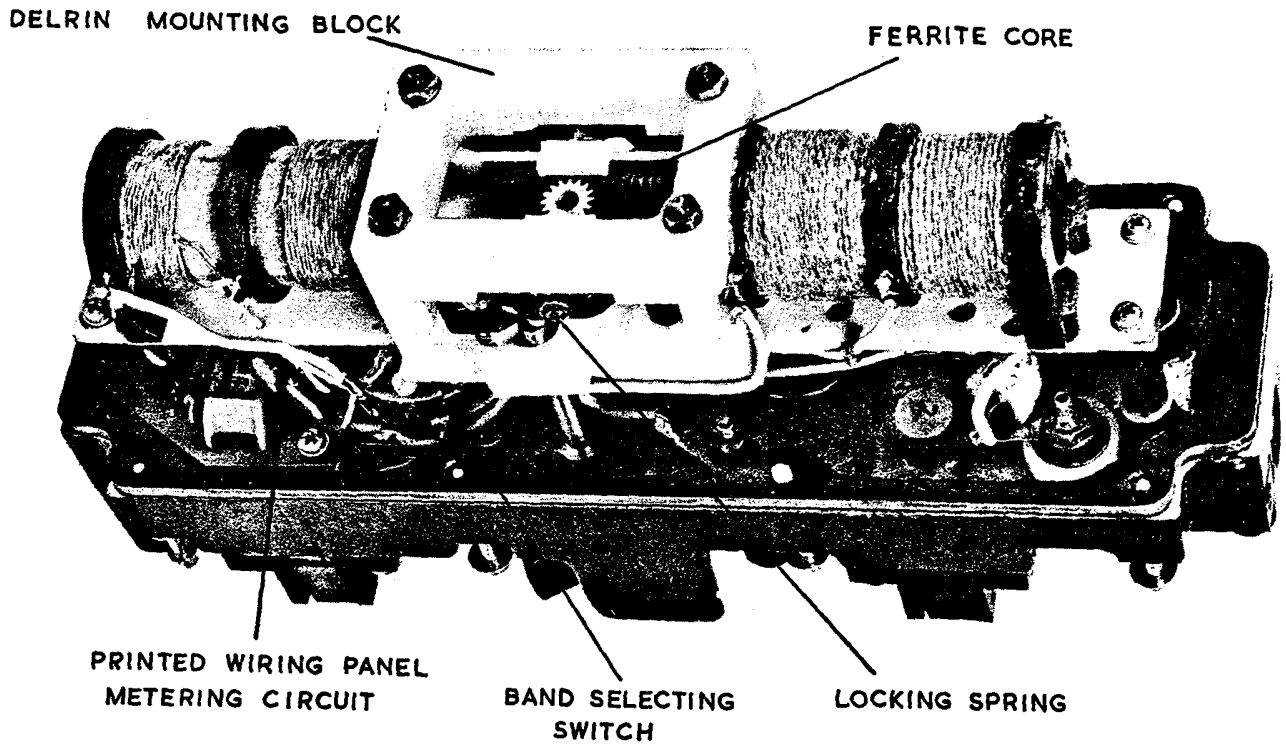

Fig 28 - Tuner, r.f., interior view

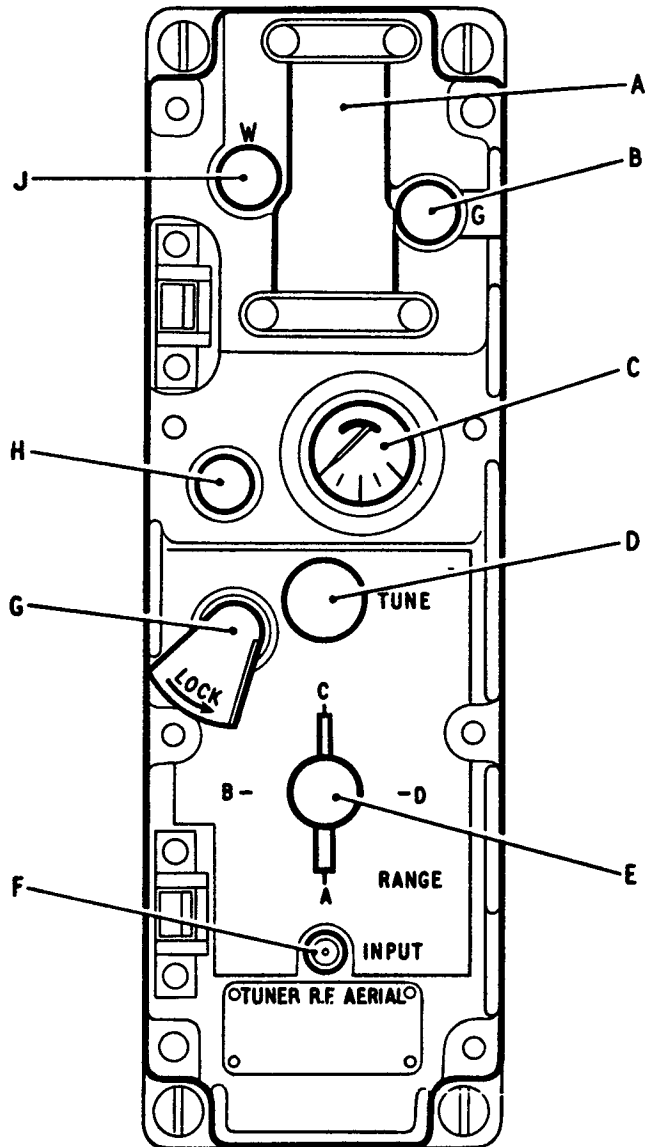

Fig 29 - Tuner, r.f., controls

DETAILED TECHNICAL DESCRIPTION

Matching
(Fig 30)

228. The matching into the various antennae from the 50Ω source of the TRA13 or R.F.A. No 12 is achieved by a pi coupling unit.

229. The band is divided into four ranges which are selected by the range switch S1, which switches to one of the four input shunt capacitors C1, C2, C3 or C4 and the respective series inductors L1-L4. The latter are continuously tunable, the variable inductance being achieved by a sliding ferrite core driven via rack-and-pinion from the TUNE control on the front panel. The output shunt capacitance is made up of the antenna capacitance plus strays, in addition when the ground antenna is used the capacitor C11 is connected in parallel by connecting TP2 to TP3. When a wire antenna is used, 60pF of series capacitance (C9, C10) is provided to ensure tuning over the entire tuning range.

Metering
(Fig 31)

230. It is required that meter deflections between one third and full scale are obtained over the entire frequency range and with all types of antennae. To ensure this, metering is effected by measuring the p.d. developed across the capacitor C5 by the antenna current which flows through it. This voltage is proportional to the antenna current and inversely proportional to the frequency. As the antenna current tends to rise with frequency, the resultant voltage is effectively constant over the frequency band, further frequency compensation is provided by series capacitor C8 and shunt resistor R1 before the signal is rectified by D1.

231. The rectified d.c. is now passed into a meter sensitivity circuit. This circuit ensures that the requisite meter deflection is obtained irrespective of whether the unit is being fed with low power (0.5-1.5W) from the TRA13 or high power (8-16W) from the R.F.A. No 12. This is achieved by making use of the fact that the output circuit of the TRA13 is open circuit to d.c. signals, whereas the R.F.A. No 12 has a low d.c. resistance output circuit, as shown diagrammatically by the choke (R.F. AMP) and capacitor (TRA13) in Fig 31.

232. On low power the entire diode current from D1 flows through the resistor combination R5, R2 and R3 and thence through the meter circuit, which is made non-linear by the shunt comprised of D2 and R4. On high power, ie when the R.F.A. No 12 is connected, it will be seen that some of the diode current will be shunted via the low d.c. resistance path provided by the output circuit of the amplifier.

233. It has been found necessary to employ the network R2, R3 and R5 in order that a reasonably constant source impedance is presented to the non-linearising meter circuit of R4 and D2. The resistor R6 increases the meter circuit resistance and hence the shunting effect of R4 and D2 at higher values of applied p.d.

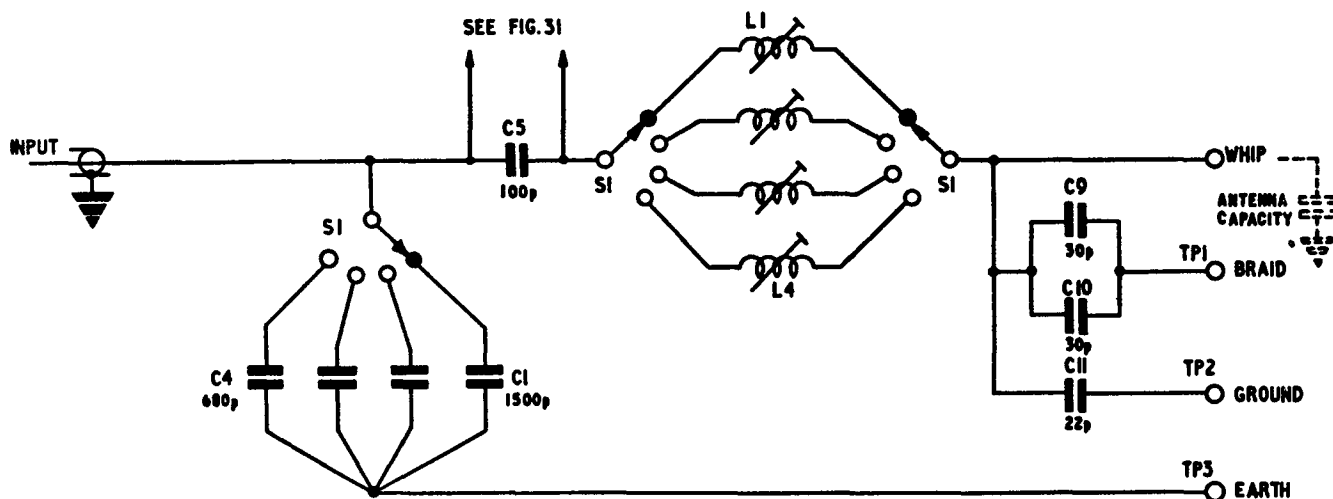

2105/00

Fig 30 - Tuner, r.f., tuning circuit, simplified

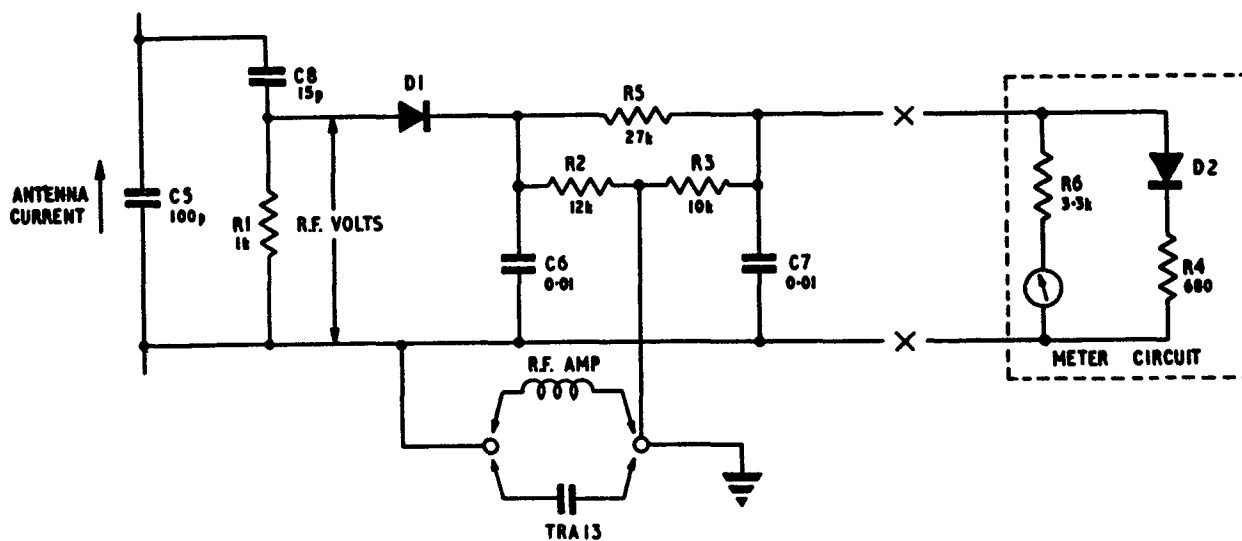

2105/00

Fig 31 - Tuner, r.f., metering, simplified circuit

HARNESS ADAPTOR UNIT (H.A.U.), Mk.2

BRIEF TECHNICAL DESCRIPTION

General

234. The unit is a mechanical and electrical adaptor which permits the TRA13 and R.F.A. No 12 Mk 1 and 2 to be mounted and operated in a vehicle which has a nominal 24V supply and which is fitted with a Radio control harness, type A or B.

235. The mechanical structure permits the TRA13, R.F.A. No 12 Mk 1 and 2 and Tuner, r.f. to be solidly mounted and itself then provides the necessary protection against mechanical shock and vibration.

236. The electrical circuits provide the following:

- a. A regulated nominal 12V supply from the vehicle supply, the latter may vary from 20.6V to 31.6V.
- b. An audio amplifier which increases the normal 5mW of the TRA13 to 150mW which is normal for vehicle sets.
- c. An attenuator to reduce the vehicle microphone levels to that normal for the TRA13.
- d. The necessary conversion from a 6-way, pattern 105 headset socket (TRA13) to a 12-way, pattern 104 (Mk 4B) which is normal for vehicle sets.
- e. The Mk 2 version has an additional 24V supply for the R.F.A. No 12 Mk 2 (when used).

Construction

237. The unit is contained in a cast aluminium alloy sealed box which both houses the electrical circuitry and also provides the mounting for the TRA13, R.F.A. No 12 Mk 1 and 2 and Tuner, r.f. It is heavily finned to supply the necessary heat dissipation for the power transistors used in the unit. Also mounted on the unit is a table showing various antenna lengths/frequency etc. This duplicates the chart which is fitted on the Tuner, r.f. as this is obscured when mounted on the adaptor unit.

238. Its physical characteristics are:

Height	-	8 in.
Width	-	24 in.
Depth	-	6 in.
Weight	-	30 lb

Controls

239. Fig 32 and Table 5 give details of the controls.

Table 5 - Harness adaptor unit, controls

Item	Fig ref	Remarks
Lamp IIP1	A	Indicates when unit is switched on. Fitted with red dimmer cap
Fuse FS1	B	7A fuse in input to SRA13 after series regulator
ON/OFF switch SA	C	Switches power input to unit
6-way, pattern 105, socket SK3	D	Socket connection to SRA13
2-way, pattern 104, plug PL1	E	24V input to unit
12-way, pattern 104, socket SK2	F	Connections to radio control harness
Fuse spare	G	7A fitted behind plate
Shock mounts	H	To absorb mechanical shock and vibration
2-way, pattern 104, socket SK4	J	24V output to Amplifier, r.f., No 12, Mk 2

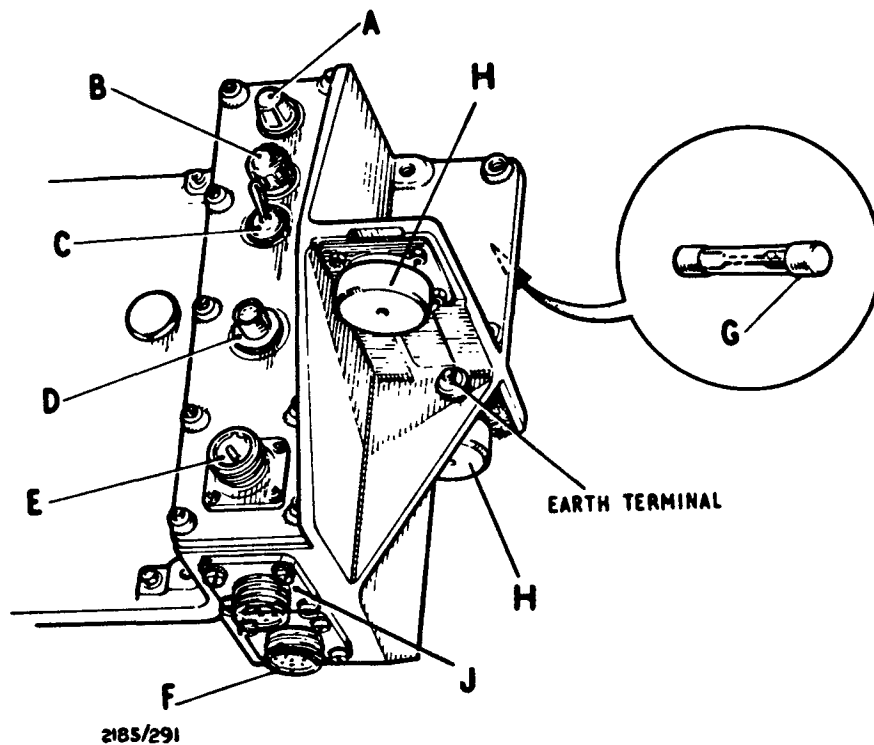

Fig 32 - Harness adaptor unit, controls

DETAILED TECHNICAL DESCRIPTION

Voltage and current regulator
(Fig 33)

240. The input to the unit first passes through a r.f. filter L1, C1 and C2 and then to the supply switch SA. It then passes into a low frequency filter made up of L2 and C4, the rectifier D2 giving protection to the regulator circuits against polarity reversal. Additional polarity reversal protection is provided to the SRA13 by the sensing relay combination RLA and D1. The relay contact RLA1 also ensures that if the batteries have been left in the SRA13 that they do not discharge back through the adaptor unit when it is switched off. A 24V supply is taken off after the input filter and D2 to SK4, this provides the supply to the R.F.A. No 12 Mk 2 (if used).

241. The voltage regulation is achieved by a conventional series regulator, the series regulator being the parallel combination TR5, TR6 and TR7. The output voltage is compared by TR1 with the reference voltage developed across the Zener diode D3, the base voltage of TR1 being set by RV1 to give an output voltage of 12.7V with an input voltage of 31.6V. The output voltage will then remain within the limits 12.0-13.0V at any input voltage between 20.6 and 31.6V and at any load current up to 6A. The collector output which results from the comparison of base and emitter voltage is fed to the emitter followers TR2, TR3 and TR4 which in turn control the series regulators.

242. The load current being drawn passes through R13 and the voltage drop across it is sensed by TR8, if this is excessive the collector output will control TR2, TR3 and TR4 and then the series regulators to prevent the load current reaching damaging proportions.

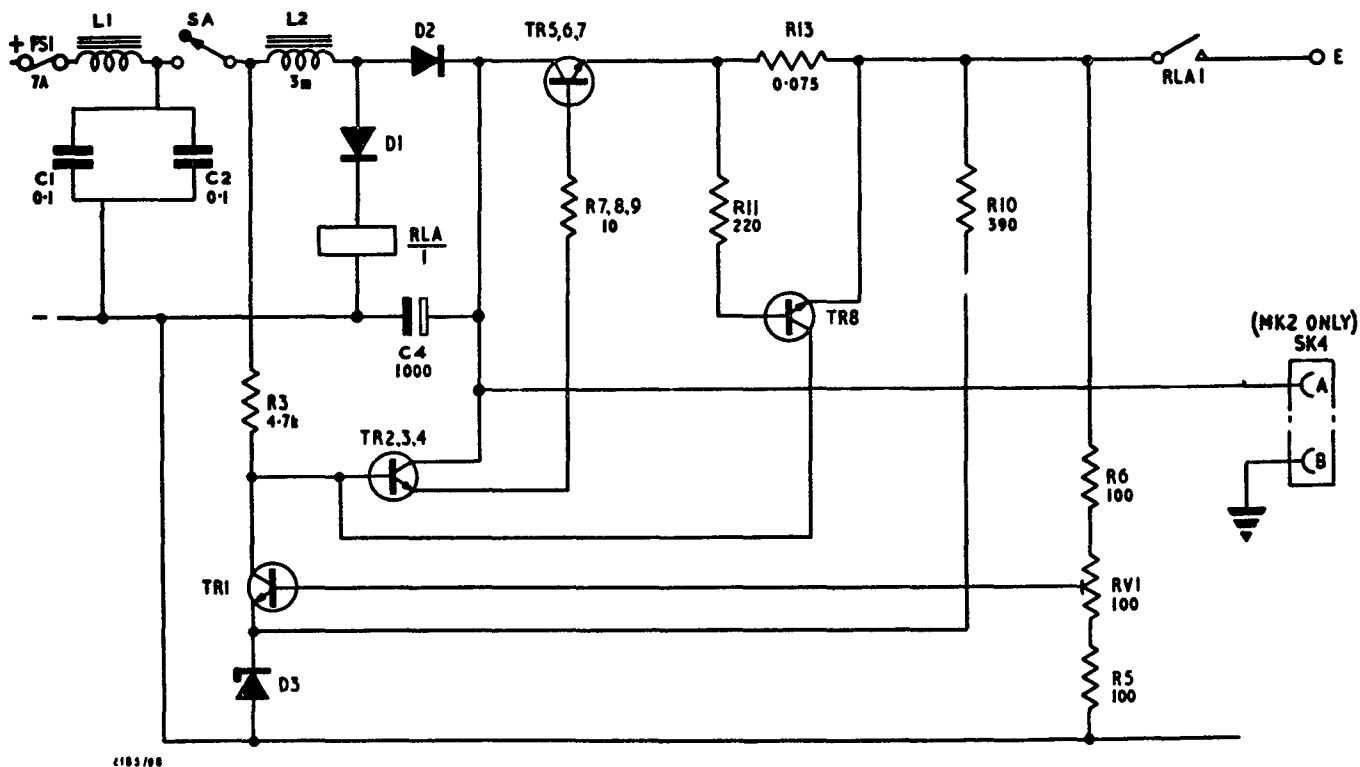

Fig 33 - H.A.U., voltage and current regulator, simplified circuit

Headphone amplifier
(Fig 2589)

243. The audio output from the SRA13 is applied via SK3 pin F to C10 and via T2 secondary (7, 8) to the base of TR9, the collector load of which is T2 primary (1, 4). The other secondary of T2 (5, 6) is connected to the set phone pins of SK2 (M and G), the secondary (7, 8) is phased to provide negative feedback.

Microphone attenuator

244. The microphone input from the control harness appears across pins A and B of SK2, after attenuation in the pad R1, R2 and R4 it is applied to the primary of T1, the secondary of which then feeds to the microphone pins of the SRA13, ie A and D of SK3. In the Mk 2 version T1 secondary is taken to earth via C13, this has been found necessary to prevent instability when the R.F.A. No 12, Mk 2 is being used.

245. The transmit/receive switching line is routed through from SK3 pin C to SK2 pin D.

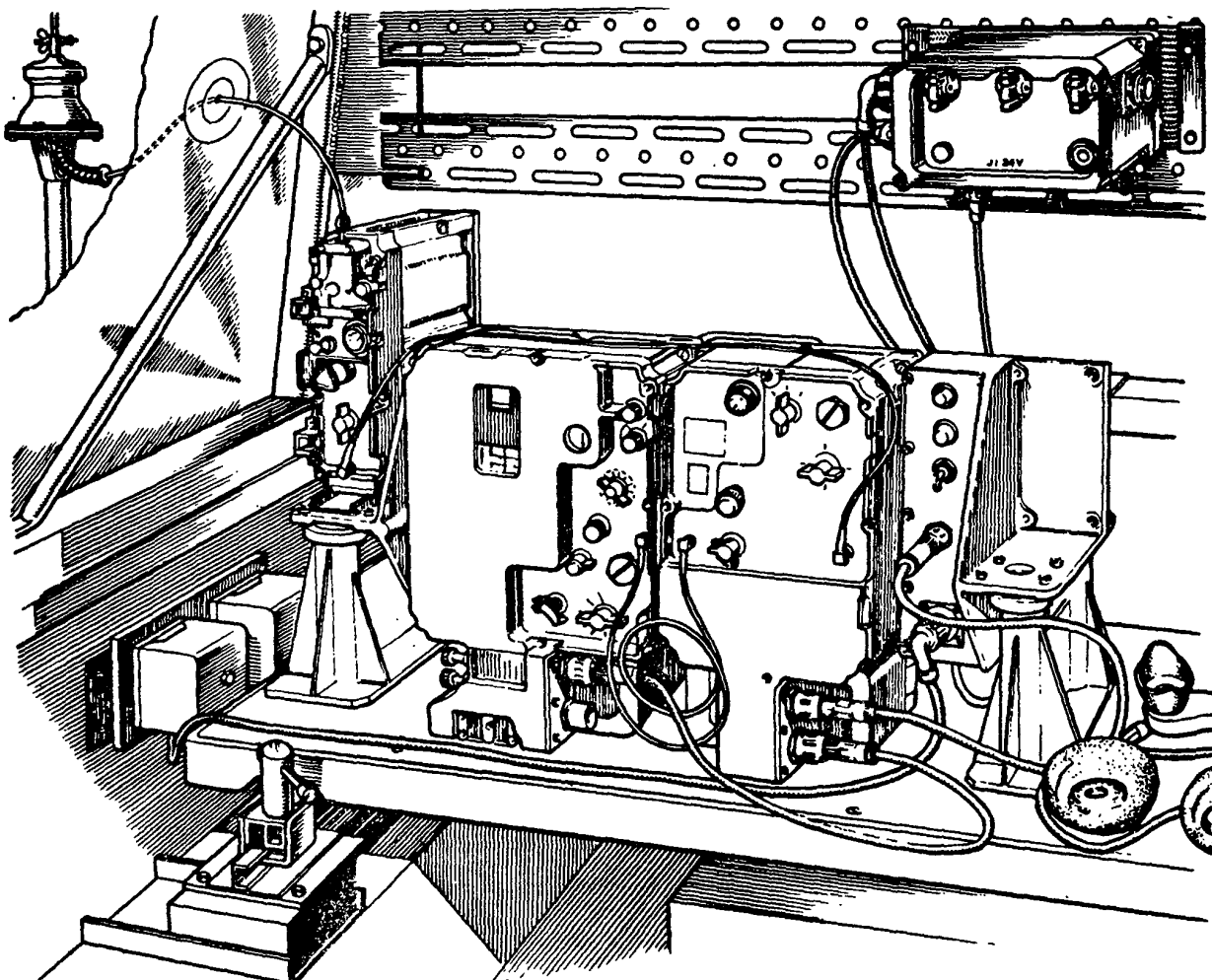

Fig 34 - SRA13 installed in vehicle

AMPLIFIER, R.F., No 12 Mk 1
(see para 311 to 335 for Mk 2 version)BRIEF TECHNICAL DESCRIPTIONGeneral

246. The unit is a transmitter power amplifier operating over the frequency range 2-8MHz, it provides 10dB amplification to the 1.5W r.f. from the TRA13. It will handle phase modulation of up to 1400Hz deviation, c.w. keying up to 25 w.p.m. or amplitude modulation of up to 100%. The nominal input and output impedance is 50Ω.

247. A d.c. converter is included which provides the necessary supply voltages to the quick heat amplifying valve. Power for the converter is derived from a 12V nickel cadmium battery (similar to that used in the TRA13) which is connected in parallel with the TRA13 battery. A life of approximately 6 hours can be expected from the battery with a transmit/receive ratio of 1:9, this can be extended by using the hand generator to float charge the batteries.

248. When the amplifier is not in use the antenna is connected via a change-over contact to the TRA13. The Tuner, r.f., antennae is used in conjunction with the R.F.A. No 12 when whip or end-fed antennae are used, or if a resonant dipole is used this may be fed directly from the amplifier.

Controls

249. Fig 35 and Table 6 give details of the controls.

Table 6 - R.F.A. No 12, Mk 1 controls

Item	Fig ref.	Function
Meter	A	Used for p.a. tuning only
System switch SA	B	OFF - Amplifier inoperative, antenna switched through to TRA13 TUNE PA - Used for tuning OPERATE - Amplifier operating on modulation system as selected by TRA13 system switch
RANGE switch SB	C	Selects one of four frequency ranges as shown on panel
TUNE control C11	D	This is the tuning capacitor control
OUTPUT socket SK1	E	R.F. output to Tuner, r.f., or dipole antenna
LOCK	F	Mechanical lock for TUNE control
Sockets SK4	G	These are used for (a) Connection to TRA13;
SK5	H	(b) Headset or key or Harness adaptor unit. They are identical
INPUT socket SK2	J	R.F. input from TRA13

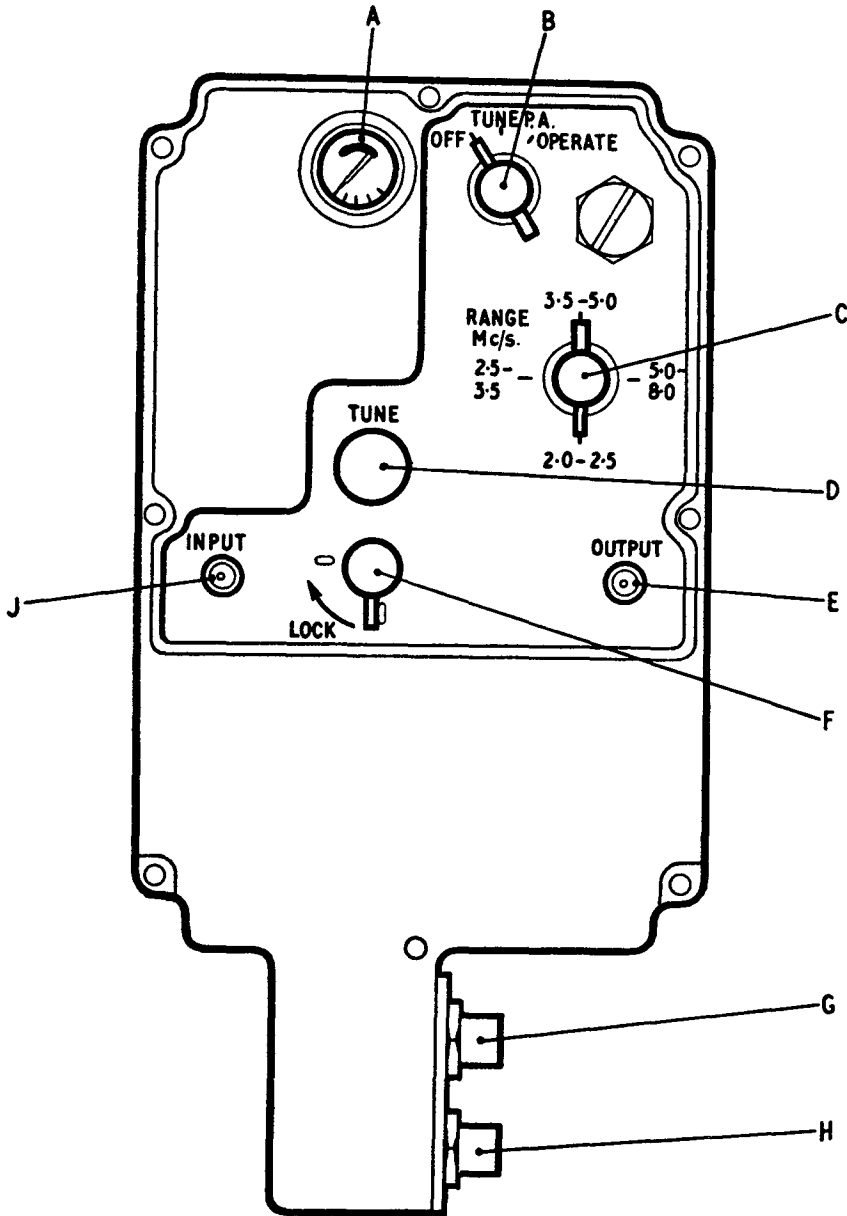

Fig 35 - R.F.A. No 12 Mk 1 controls

Construction

250. The unit is completely sealed, a Hyclad gasket being used between the front panel and the case.
251. The front panel is an aluminium alloy casting and carries the entire amplifier. The case is a magnesium casting.
252. The battery plugs on to the front panel and fits into a battery compartment which is part of the case, similar to that described for the TRA13.
253. The amplifier employs a mixed construction, certain components are mounted on two printed wiring boards, the inductors and range switch are assembled as a module, the d.c. converter is a plug-in module, the remainder of the unit employs individually mounted components.
254. The coding uses a prefix to denote the physical location of components, ie:

Prefix 1, front panel or chassis mounted
2, grid printed board
3, relay delay printed board
4, d.c. converter

255. Its physical characteristics are:

Height	-	12.1/4 in.
Width	-	6 in.
Depth	-	6 in.
Weight	-	9.1/2 lb

DETAILED TECHNICAL DESCRIPTIONTransmit-receive switching and relay operation
(Fig 36)

256. There are three relays, 3RLA, 1RLB and 1RLC concerned with the transmit-receive switching. Relay 3RLA is concerned with switching the 12V supply to the d.c. converter, whilst 1RLB and 1RLC provide the switching of the r.f. from the TRA13 and the antenna circuits respectively.
257. Relay 3RLA is prepared for operation if system switch SA is in the TUNE PA or OPERATE positions, the 12V supply being connected via SA. In the TUNE PA position an earth is connected to the key/pressel line via SA, and in the OPERATE position of SA this earth will be provided by the key or pressel connected at any of the headset sockets on the TRA13, R.F.A. No 12, Remote control unit or via the harness adaptor unit.
258. This earth completes the bias chain 3R15, 3R14, 3D1 and 3R13 and 3TR1 conducts, this in turn biases 3TR2 to a saturated on condition and 3RLA operates, contact RLA1 completing the 12V supply circuit to the d.c. converter.
259. At the same time capacitor 3C13 charges via 3D1 and 3R13 and when the key/pressel is released the -ve charge on 3C13 will hold 3TR1 in a conducting condition, 3C13 will now discharge via 3R15 and 3TR1 plus 3R16 and after about 5-7 seconds will reach a value at which 3TR1 will cut off and in so doing cut 3TR2 off and cause 3RLA to release. This delay is

necessary to ensure that the valve is maintained operating during keying or short breaks in the pressel operation, obviating clipping which might otherwise occur due to the short delay whilst the valve is reaching an operating condition.

260. Relay 1RLB is prepared to operate in the OPERATE position of SA and an earth on key/pressel line completes its circuit. In the TUNE PA position an earth via SA holds 1RLB permanently operated. Its contact RLB1 switches the r.f. input from the TRA13 via SK2 to the grid of the amplifier 1V1.

261. Relay 1RLC is prepared to operate via SA only in the OPERATE position of SA, an earth from a key or pressel closure causing it to operate. Its contact RLC1 switches the r.f. output from the amplifier via SK1 to the antenna or r.f. tuner.

262. In the non-operated positions of 1RLB and 1RLC, ie when SA is at OFF or the pressel/key are not operated, the contacts RLB1, RLC1 connect the antenna via tuner, r.f., if in use, to the TRA13.

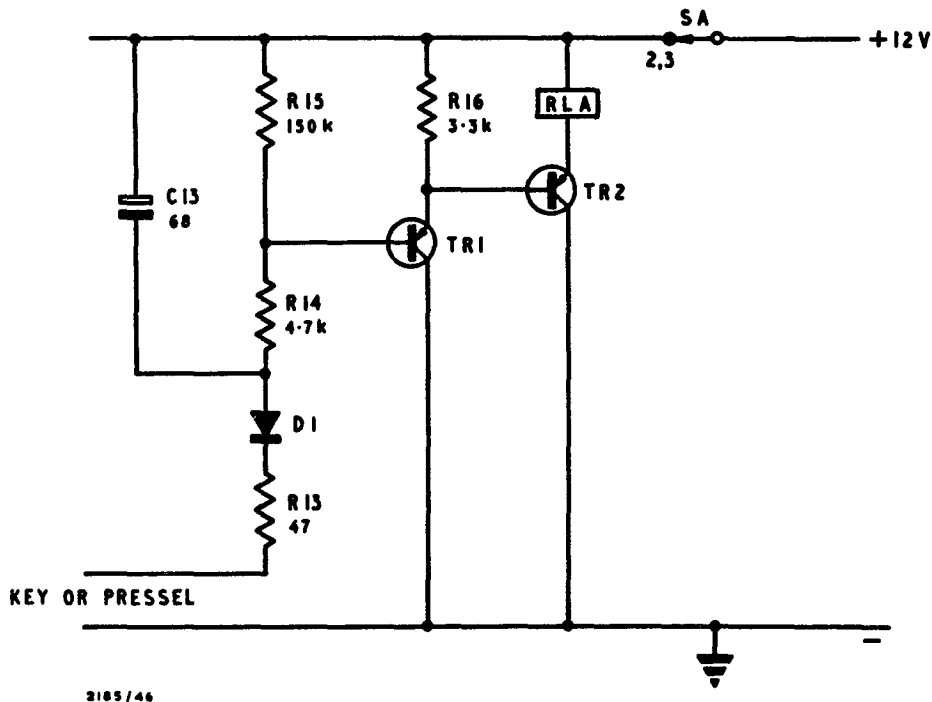

Fig 36 - R.F.A. No 12 Mk 1, relay delay, simplified circuit

R.F. amplifier

263. The amplifier valve (QZ 0620) used is of the quick heat type taking 1 sec to reach an operational condition after the pressel/key is operated, by this means no standby condition is required and economy in battery drain results.
264. The amplifier operates in two modes as a class C amplifier when the TRA13 is switched to c.w. or phase modulation or as a linear amplifier when the TRA13 is switched to amplitude modulation. This change of operation is controlled automatically by the setting of the system switch on the TRA13.
265. When the TRA13 is switched to phase modulation or c.w. conditions, pin B of SK4 and SK5 does not receive a 12V supply and relays 1RLE and 1RLF remain unoperated. The valve 1V1 is now biased and receives a screen supply such that it is operating under class C conditions, its drive from the TRA13 is also at full level.
266. When the TRA13 is switched to amplitude modulation a 12V supply is switched through to the R.F.A. No 12 causing relays 1RLE and 1RLF to operate. The contacts of these relays then perform the following functions:
- a. RLE1) Insert the attenuator network 2R1, 2R2 and 2R3 into the
RLE2) r.f. drive from the TRA13.
 - b. RLF1 Switches 2R5 in shunt with the screen resistors of 1V1.
 - c. RLF2 Connects the grid of 1V1 via 2L2 to the fixed bias supply virtually short circuiting 2R4 and 2R17 which supply additional bias under class C conditions.
267. These changes cause the valve 1V1 to operate as a linear amplifier.
268. The amplifier has a tuned anode circuit, switched into four frequency bands viz:

2.0-2.5MHz tuned by 1T2 and 1C5)	} Together with padder 1C10 and variable capacitors 1C11
2.5-3.5MHz tuned by 1T3 and 1C6)	
3.5-5.0MHz tuned by 1T4 and 1C7)	
5.0-8.0MHz tuned by 1T5 and 1C8)	

269. The anode supply to 1V1 is via the r.f. choke 1L3, decoupling being provided by capacitor 1C4. The r.f. output is taken off the secondary of the tuned r.f. transformer and fed via RIC1 to the output socket SK1.

D.C. converter

270. This is basically a push-pull square wave oscillator as described in Tels A 339. The filter circuit 4L1, 4C1 preventing hum being fed back into the R.F.A. No 12 and TRA13 via the battery supplies.
271. The output of the h.t. secondary of 4T1 (11, 12, 13) is rectified by the bridge 4D1, 4D2, 4D5 and 4D6, the resultant output being at either 350 or 250V dependent upon the tap selected by relay contact 4RLD1, the action of 4RLD is described in para 273.
272. The output of the bias secondary 4T1 (3, 7) is rectified by the bridge 4D3, 4D4, 4D7 and 4D8, the output being stabilized by the Zener diode

4D10 at 43V.

273. To prevent the amplifier being overrun by a short circuit at the output, or by mistuning, the r.f. output is sensed by the diode 1D2, the rectified voltage being applied to the base of the switching transistor 4TR3, if this voltage reduces beyond a level equivalent to about 5W output from the amplifier, the diode conducts causing 4RLD to operate and its contact 4RLD1 switches the tap on the transformer, reducing the h.t. to 250V. The Zener 4D9 ensures that 4TR3 is not damaged by the application of excessive voltage.

STABILIZER, VOLTAGE, TRANSISTOR TYPE (V.R.U.)

BRIEF TECHNICAL DESCRIPTION

General

274. The unit provides a stabilized d.c. voltage to charge one SRA13 battery at a time from a nominal 24V supply. Protection circuits are included which prevent excess current being drawn from the unit, prevent the battery discharging into the unit in the event of the 24V supply being disconnected and against damage due to polarity reversal of the input supply.

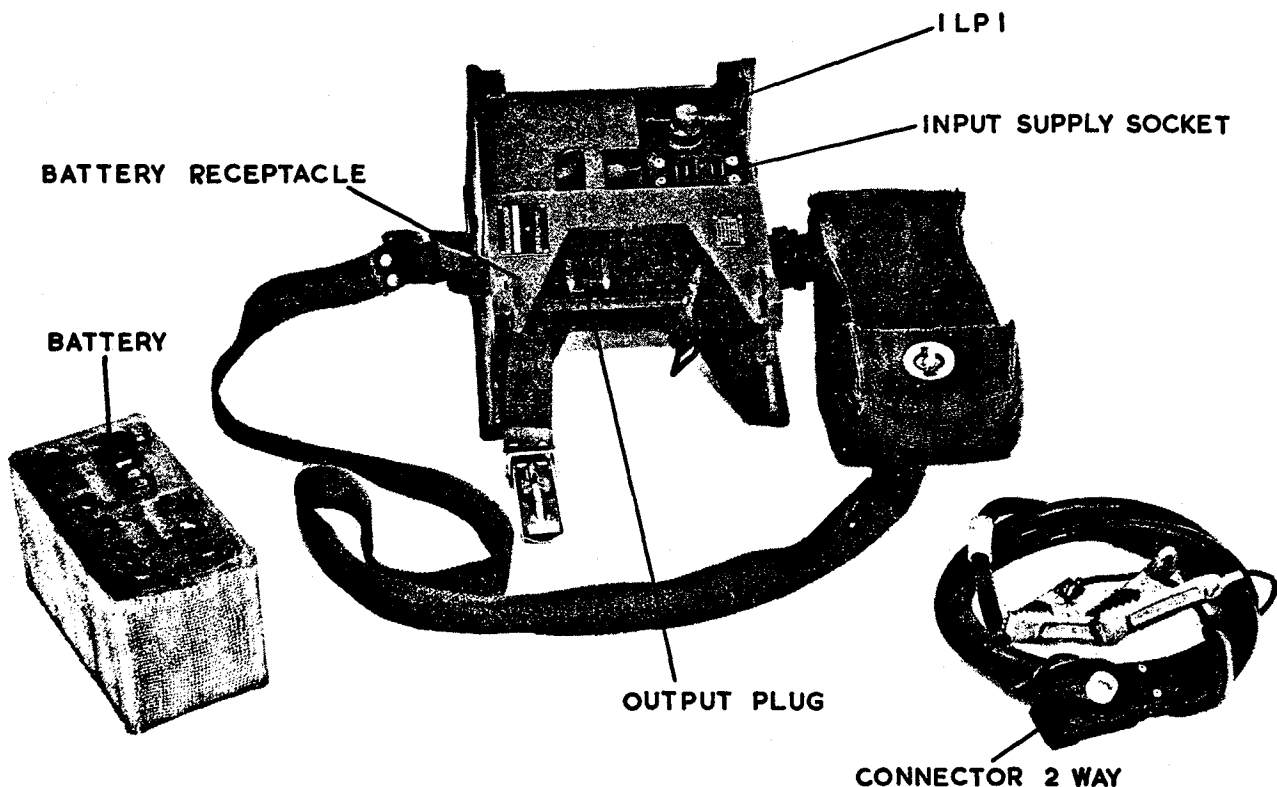

Fig 37 - V.R.U., layout and controls

275. The input to the unit is via a 2-pole socket similar to that fitted for float charging on the TRA13, the battery plugs into a receptacle which is fitted with a two pronged plug similar to the battery carrier on the TRA13 and R.F.A. No 12.

Construction

276. The unit is contained in a sealed cast aluminium alloy case.

277. Its physical characteristics are:

Height	-	6 in.
Width	-	7.1/4 in.
Depth	-	4 in.
Weight	-	3 lb

DETAILED TECHNICAL DESCRIPTION

278. This unit employs a series regulator and current limiter similar to that described in the harness adaptor unit (para 240-242).

279. Protection against polarity reversal and battery discharge are provided by the sensing relay RLA, D1, D2 and relay contact RLA1. The series regulation is performed by TR4 and TR5, and TR3 together with R4 provide the current overload sensing circuit.

280. The output voltage is stabilized at $14.5 \pm 0.3V$ at input voltages between 20.6 and 31.6V. The current limiting circuit operates to prevent a current in excess of 3A being passed by the unit.

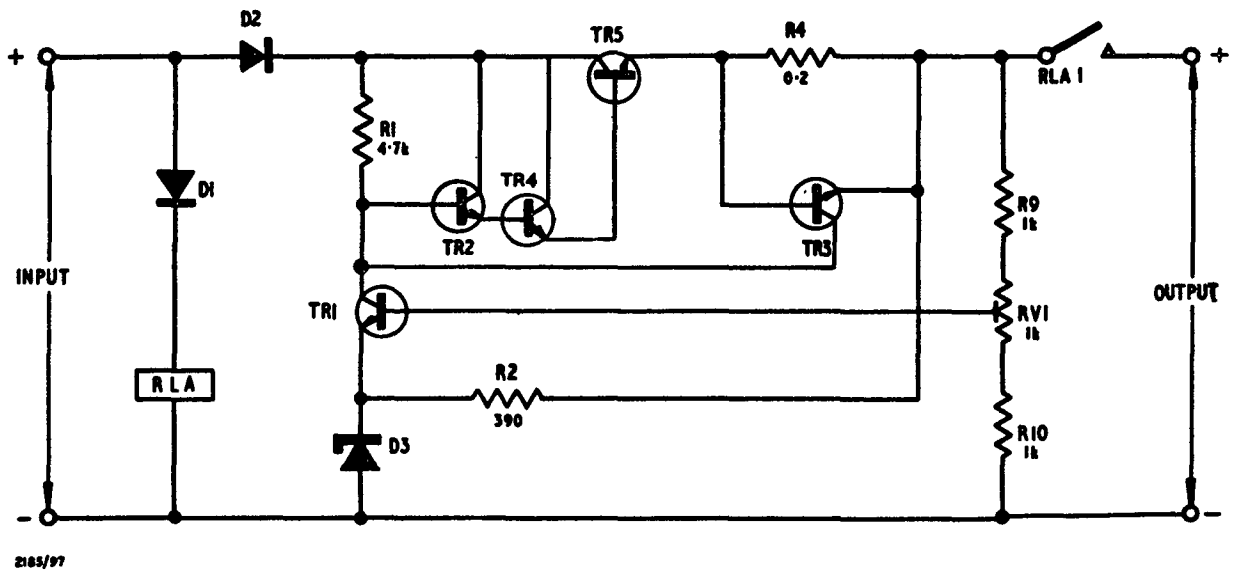

Fig 38 - V.R.U., voltage and current regulator, simplified circuit

GENERATOR, D.C.

BRIEF TECHNICAL DESCRIPTION

General

281. The generator (which in fact is a 3-phase alternator and rectifier) is a hand-operated device intended for:

- a. Float charging the batteries of the SRA13, ie whilst the set is being operated.
- b. Charging an SRA13 type battery.

282. The generator is designed to produce an output voltage of 14.2-14.6V at winding speeds of 65-100 rev/min and for load currents in the range 10mA-2.1A over an ambient temperature range of -32°C to +55°C.

283. Protection is included against accidental short circuits, battery discharge if the generator is not wound and overwinding. Lamp indication is provided to indicate that the winding speed is adequate for charging.

Construction

284. The unit is contained in a fully sealed die cast aluminium case whose physical characteristics are:

Height	-	7.1/2 in.
Width	-	5.5/8 in.
Length	-	8.1/2 in.
Weight	-	12 lb

285. The case consists of two castings which bolt together, sealing being provided by a Hyclad sealing gasket.

286. One casting known as the housing assembly contains the permanent magnet alternator and a two stage helical gear box which provides a 25:1 step up ratio between the handle and the alternator shaft. Thus at a handle speed of 65 rev/min the alternator shaft speed is 1625 rev/min.

287. The other casting known as the casing assembly contains the rectifiers, electronic regulator and indicator circuits. The electronic circuits are mainly carried on printed wiring boards, but the power transistors are mounted on an aluminium panel which serves as a heat sink.

288. Electrical connections between the two castings are made by a unitor type plug and socket PLA and SKA.

289. The unit is fitted with three lugs which permit it to be attached to a carrying frame merely by the tightening of one knurled knob. A spike can be fitted to the rear of the unit by four screws; this spike, which resembles a coach bolt, permits the generator to be screwed on to a tree, gatepost, etc, for operation; alternatively it may be operated on the carrier.

290. The unit is fitted with a 1.1/4 in. silica gel desiccator.

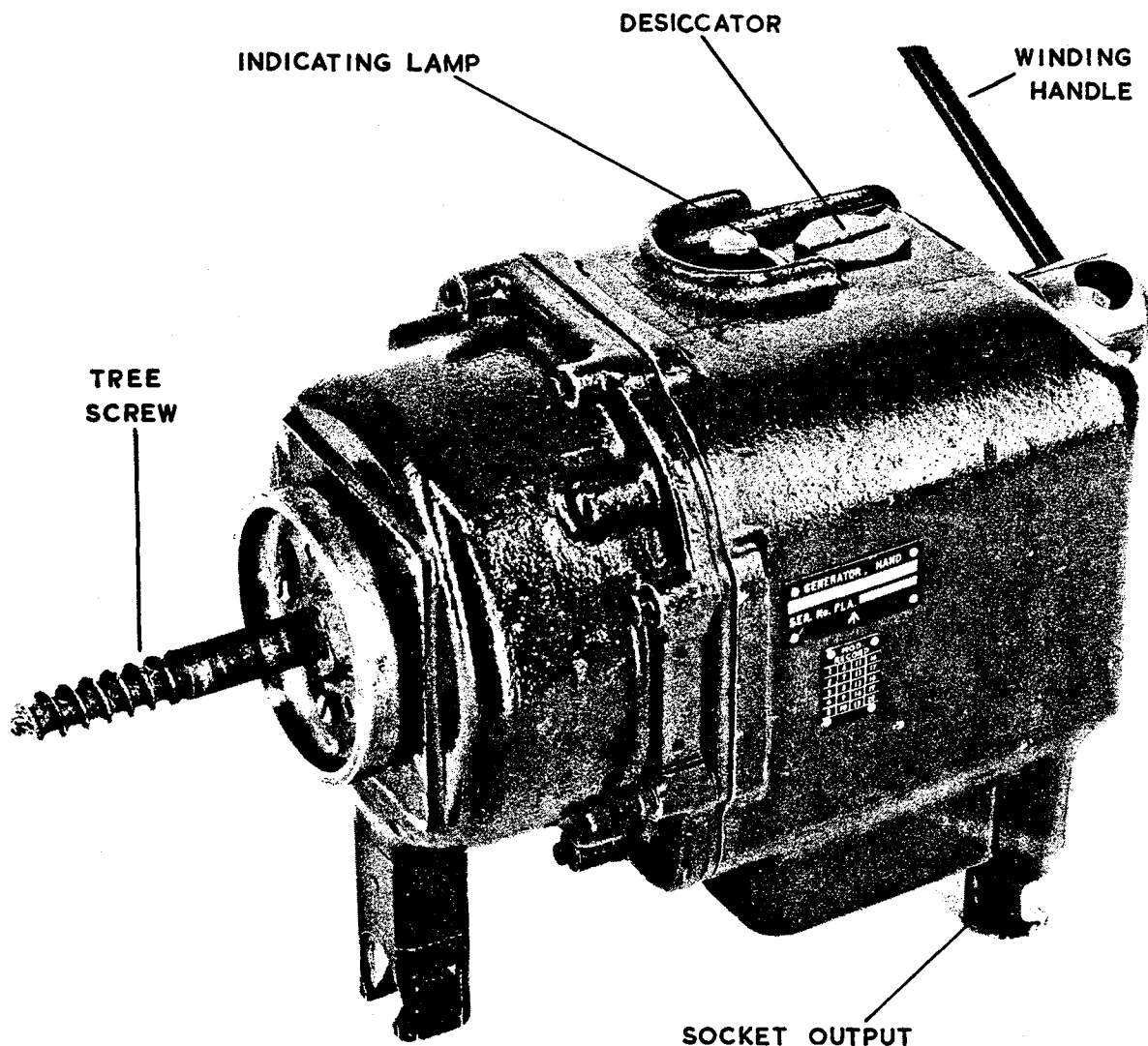

Fig 39 - Generator, d.c., controls

DETAILED TECHNICAL DESCRIPTIONGenerator and rectifier

291. The generator has a 12-pole permanent magnet rotor and one 12-pole, 3-phase wound stator, thus at a handle speed of 65 rev/min and rotor (shaft) speed of 1625 rev/min the output frequency will be:

$$\frac{1625 \times 6 \text{ (pairs of poles)}}{60} = 162.5\text{Hz}$$

292. With the alternator on an open circuit load and a shaft speed of 1625 rev/min, a line voltage of 23.8-29.6V will be produced. When connected to the three phase bridge rectifier which is supplying a load of 2.3A, the a.c. line voltage will lie within the limits 14.8-20.6V for a shaft speed of 1625 rev/min. If the rectifier is short circuited such as when the over-voltage protection device operates (para 305-306), the d.c. current will be limited to 7A for alternator speeds up to 2500 rev/min.

293. The three phase output from the alternator is fed via PIA, SKA to the three phase rectifier bridge. The silicon power rectifiers D1, D2 and D3 (type CV7324) are connected to the positive line and have a cathode stud whilst the three connected to the negative line D4, D5 and D6 have anode studs.

294. The capacitors C1-C6 connected across the rectifiers D1-D6 respectively prevent radio interference, which would occur due to the discharge of positive holes from the diodes as the main current changes from one rectifier to the next.

295. Smoothing is provided by the capacitors C7 and C8. These ensure that the output ripple voltage does not exceed 15mV peak-to-peak under all operating conditions down to -25°C . At temperatures below this the capacitor values fall off rapidly and the ripple voltage may exceed 15mV.

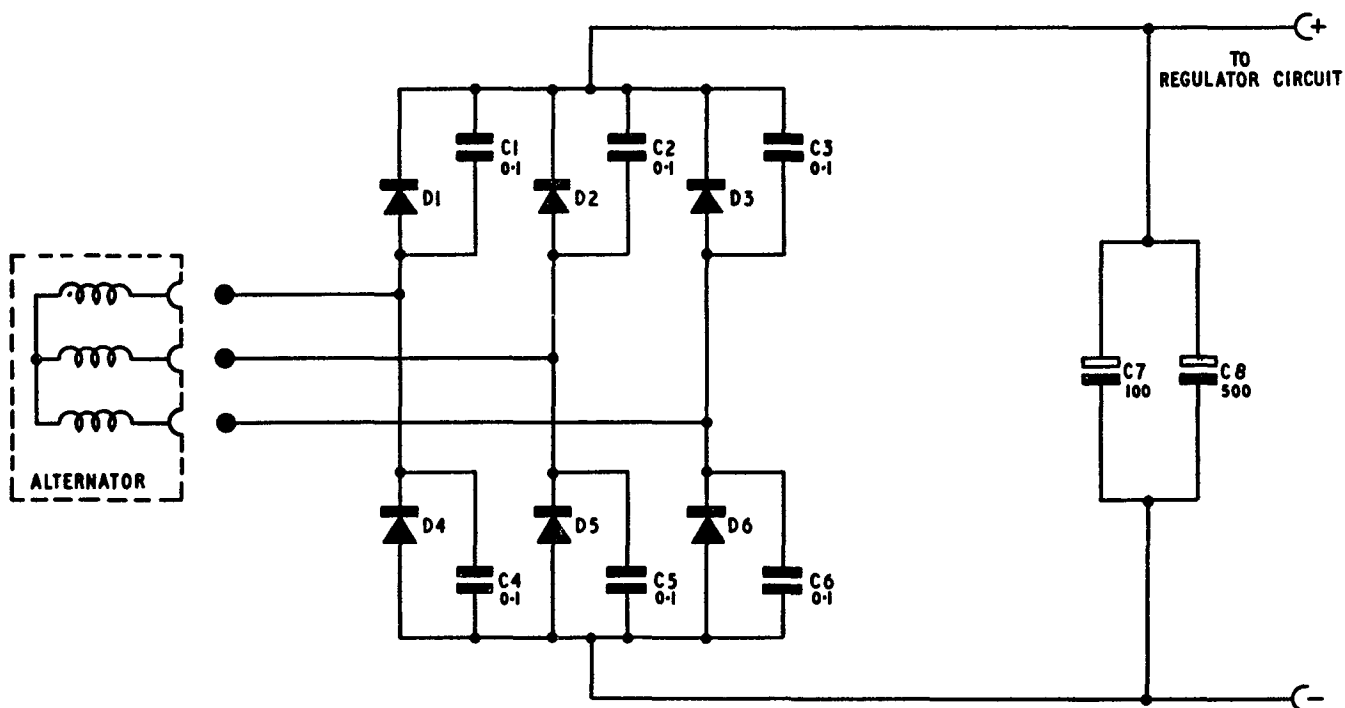

285/106

Fig 40 - Generator, d.c., generator and rectifier, simplified circuit

Voltage and current regulation

296. The voltage regulation is achieved by the use of a sensing circuit which controls two long tailed pairs in cascade acting as pre-amplifiers, these in turn control a series regulator.

297. The voltage sensing circuit consists of the long tailed pair TR13, TR14, the base of TR14 being connected to the slider of RV1 which forms part of the voltage dividing chain R32, RV1 and R33 connected across the output voltage terminals. The base of TR13 is connected to the junction of the Zener diode D14 and R31 and thus the base emitter voltage of TR13 is held constant.

298. The outputs of TR13, TR14 are connected to the bases of the following long tailed pair TR11 and TR12, the output current of TR11 is then fed to the driver stage TR9 of the series regulator.

299. The transistors TR4-TR7 comprise the series regulator and are type CV7085 connected in parallel. Resistors R21-R24 are current-sharing resistors which ensure that there is an approximately equal power dissipation in each of the transistors. The transistors TR8 and TR9 which are also type CV7085 are used as drivers for TR4-TR7. Resistors R15-20 shunt the base-emitters of the transistors to provide a path for leakage current, thus ensuring that control can be effected at temperatures up to 55°C.

300. The circuit R13, D13, R14 and TR3 provide a constant current source of approximately 5mA in the collector of TR3. This current is shared between the base-emitter of TR9 (in parallel with R15), the collector of TR11 (long tailed pair pre-amplifier) and the collector of TR10, the current limiter. The proportions in which this current is shared depend upon the demands of the voltage regulator pre-amplifier and the current limiter. The use of this constant current device obviates the use of a pre-amplifier with a larger current handling capacity.

301. Examining the action of the entire regulator it will be seen that if the output voltage rises due to decrease in load, increase in winding speed or temperature drift in the output stages of the regulator, the sensing voltage between the positive output terminal and the slider of RV1 will increase, whilst due to the Zener action the reference voltage across D14 will remain constant. This causes the following action:

- a. TR14 base current increases.
- b. TR13 base current decreases.
- c. TR14 collector current increases.
- d. TR13 collector current decreases.
- e. TR12 base current decreases.
- f. TR11 base current increases.
- g. TR11 collector current increases.
- h. TR12 collector current decreases.
- j. TR9 and thus TR8 - TR4 base currents decrease.

k. TR4-TR9 collector-emitter volts increase and thus the original increase in output voltage tends to be corrected.

302. The capacitor C10 is connected between the positive line and the base of TR9 to prevent oscillation of the regulator circuit.

303. The circuit R25, R34 and TR10 form a current limiting circuit. If the load current exceeds 2.2A, the voltage drop across the R25, R34 combination is sufficient to make the base-emitter junction of TR10 conduct and the collector of TR10 will divert current from the base of TR9 with the resultant series-limiting action previously described. The circuit is so designed that no action takes place until the current exceeds 2.2A and it then prevents the current rising above 3A.

304. The diode D15 (CV7016) is connected in the negative line between the output terminal and R33. This prevents a battery connected to the generator discharging via R32, RV1 and R33 if the generator is not being wound.

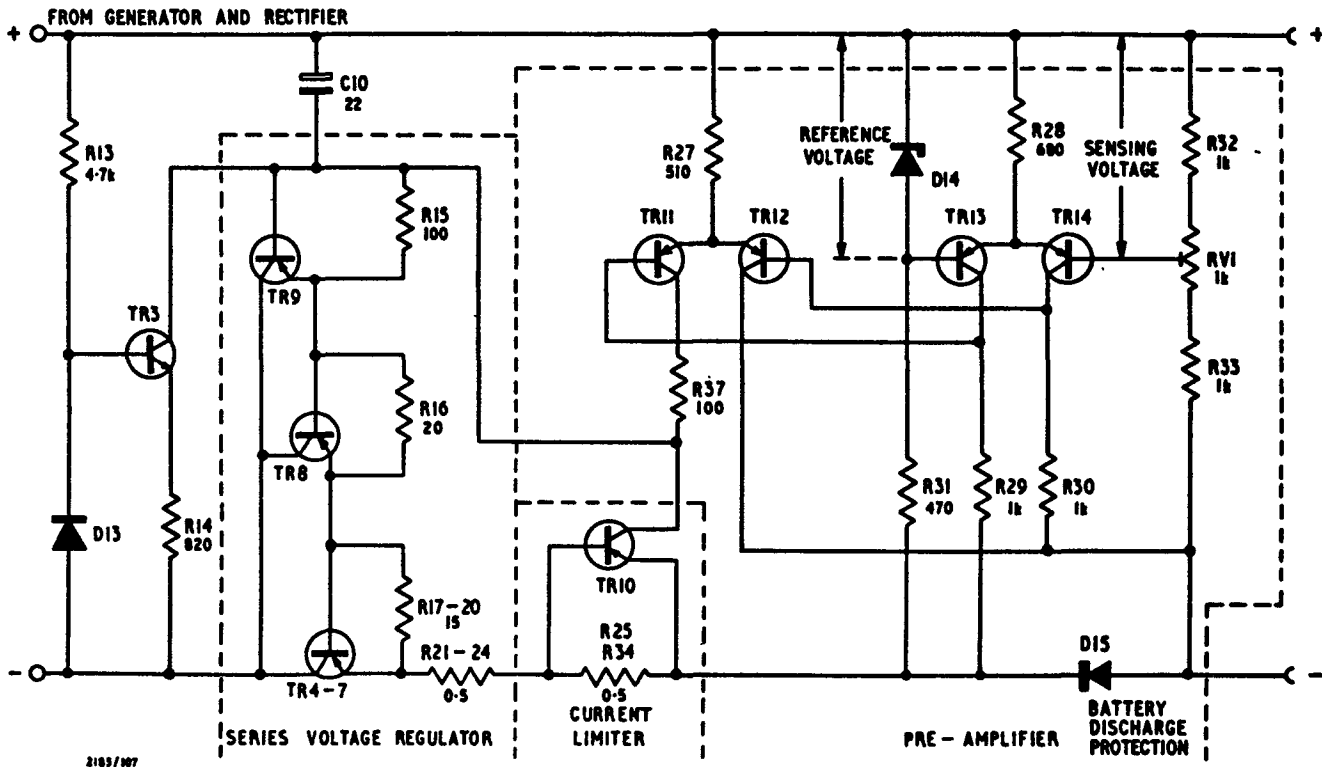

Fig 41 - Generator, d.c., voltage and current regulation, simplified circuit

Overwind protection and indicator lamp circuit

305. Overvoltage protection is provided to protect the series regulator transistors from damage due to their being subjected to too large a collector-emitter voltage.

306. The protection is afforded by the circuit comprising the two series connected Zener diodes D16 and D17 and the silicon controlled rectifier SCR1. If the output voltage from the bridge rectifier exceeds the breakdown voltage of the two Zeners (approximately 54) the diodes will pass current into the gate of SCR1 which will fire and impose a virtual short circuit on

the bridge rectifier, the load so imposed, some 5-6A of rectifier current will be more than an operator can normally produce by winding. The generator must be stopped to cause SCR1 to cease conducting once it has fired.

307. Lamp indication is provided to advise an operator that he has reached charging speed when winding. The circuit which performs this function is provided by the long tailed pair TR51, TR52, the reference diode D14 (also used in the series regulator) and the potentiometer chain R53, RV2, R52 and R51, together with the common emitter resistor R54 and collector loads R55 and ILP1.

308. The base of TR52 is connected to the negative side of the reference diode D14 and the base of TR51 to the slider of RV2. Thus the voltage of the positive rail to the RV2 slider is compared with the reference voltage.

309. At low alternator speeds TR52 will conduct, TR51 will be cut off and the lamp will not light. As the speed increases, the sensing voltage will exceed the reference voltage, and TR51 will conduct, lighting the lamp, and TR52 will cease to conduct.

310. The setting of RV2 is adjusted such that the lamp is lit at ± 5 rev/min of the minimum speed required to give the regulated voltage at full load.

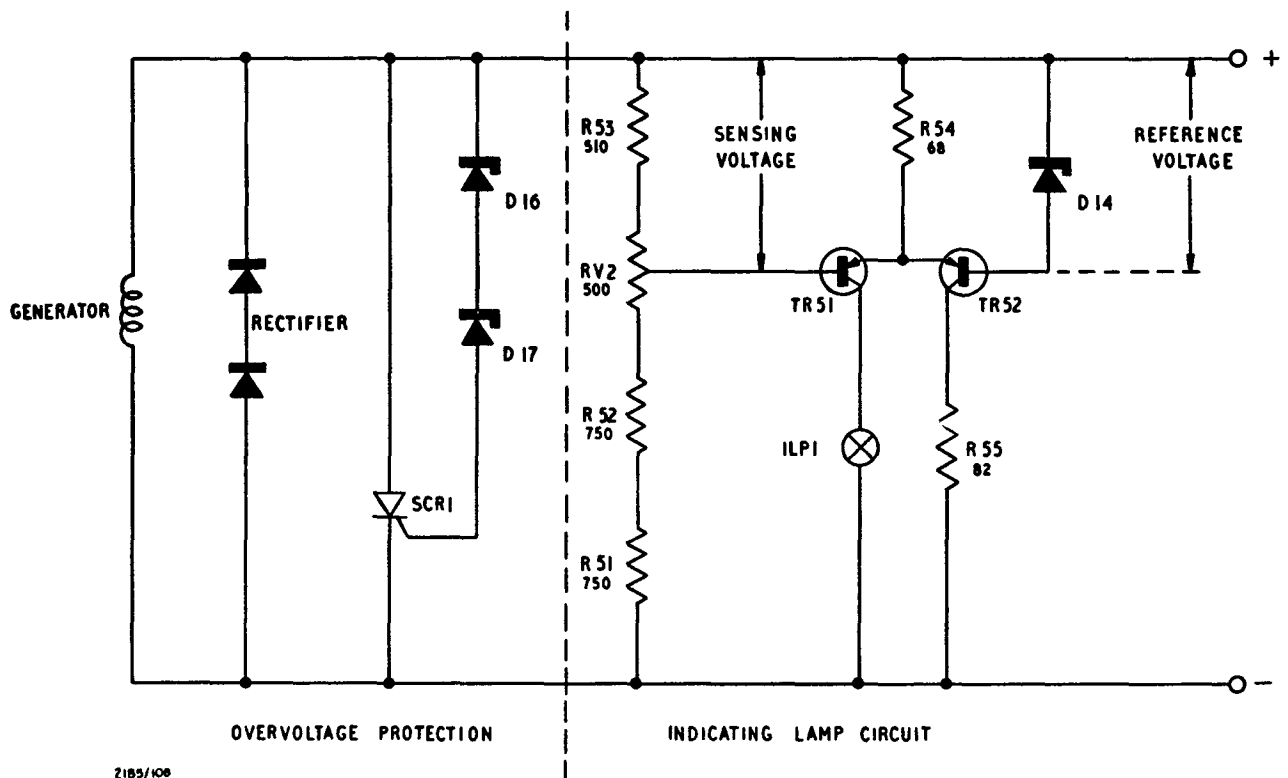

Fig 42 - Generator, d.c., overwind protection and indicator lamp, simplified circuit

AMPLIFIER, R.F., No 12, Mk 2

BRIEF TECHNICAL DESCRIPTION

General

311. This unit is a fully transistorized version of the Amplifier, r.f., No 12 and has the advantages of easier operation and a weight-saving of about 5 lb.

312. It provides a power gain of at least 10dB when driven by a TRA13, ie a minimum power of 8W on a.m. and 15W on ph.m. and c.w.

313. Its power supply is derived from the 12V battery of the TRA13 and its own 12V battery. The difference however between the Mk 1 and Mk 2 versions is that in the Mk 1 the batteries are parallel connected (12V supply) whereas in the Mk 2 they are series connected (24V supply). When used in conjunction with a harness adaptor unit the Mk 2 version of the unit must be used as this has a 24V supply outlet for the R.F.A. No 12, Mk 2.

314. When the amplifier is not in use the antenna is connected via the change-over contact to the TRA13. The Tuner, r.f., antennae is used in conjunction with the R.F.A. No 12 (either Mark) when whip or end-fed antennae are used; if a resonant dipole is used this may be fed directly from the amplifier.

Construction

315. The unit is completely sealed, a Hyclad gasket being used between the front panel and the case.

316. The front panel is an aluminium alloy casting and the case is a magnesium casting.

317. The battery plugs on to the front panel and fits into a battery compartment which is part of the case, similar to that described for the TRA13.

318. The amplifier consists of three major sub-assemblies each mounted on the front panel; these are:

- a. Relay, equalizer and d.c. supplies.
- b. R.F. amplifier.
- c. Filter unit.

319. The physical characteristics are:

Height	-	9.1/2 in.
Width	-	5 in.
Depth	-	6 in.
Weight	-	5 lb

Controls

320. Fig 43 and Table 7 give details of the controls.

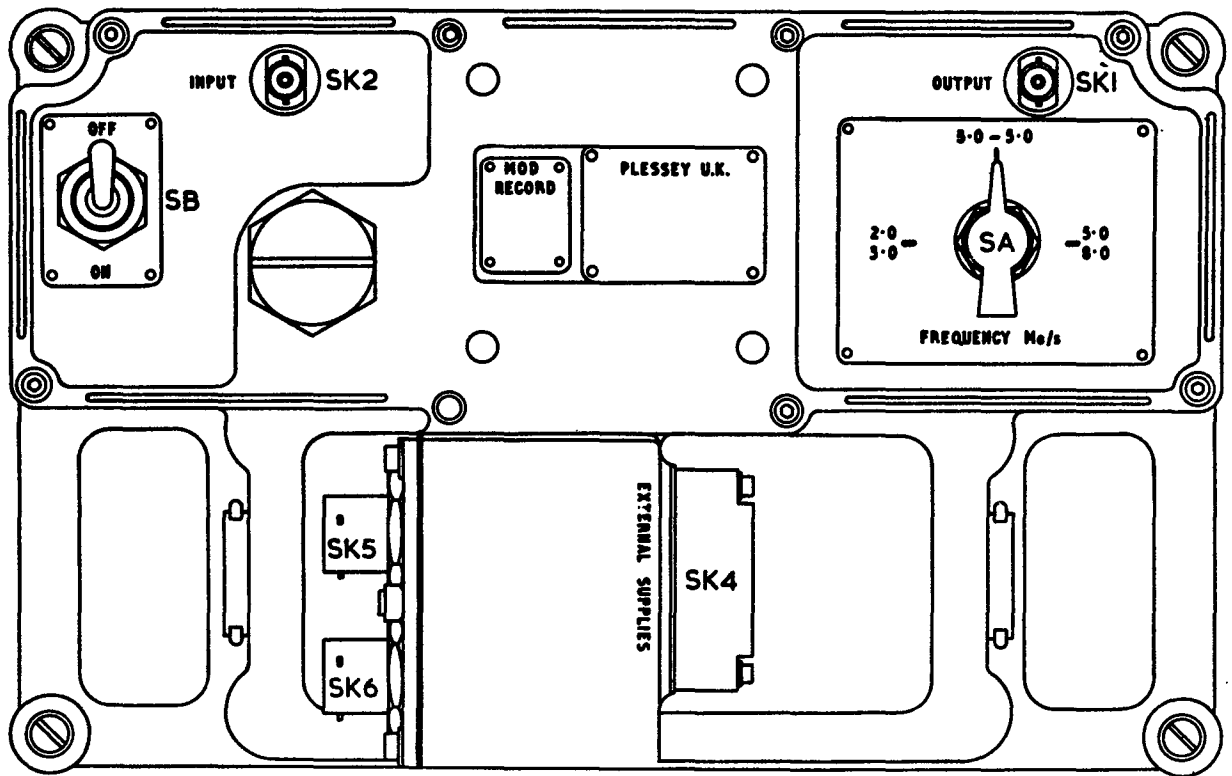

2100/270

Fig 43 - R.F.A. No 12, Mk 2, controls

Table 7 - R.F.A. No 12, Mk 2, controls

Item	Cct ref	Function
Range switch	SA	Selects operating band 2.0-3.0MHz 3.0-5.0MHz 5.0-8.0MHz
ON/OFF switch	SB	Amplifier inoperative, antenna switched through to TRA13
OUTPUT socket	SK1	R.F. output to Tuner, r.f. or dipole antenna
INPUT socket	SK2	R.F. input from TRA13
EXTERNAL SUPPLIES	SK4	To allow the amplifier to be operated from an external 24V supply, reverse polarity and over-voltage protection is incorporated
Sockets	SK5 SK6	These are parallel connected and are used for: <ul style="list-style-type: none"> a. Connection to TRA13 b. Headset or key c. Harness adaptor unit

DETAILED TECHNICAL DESCRIPTION

D.C. supplies
(Fig 2606)

321. The series connection of the two 12V batteries (TRA13 and R.F.A. No 12) to provide the 24V necessary for the operation of the amplifier is performed by relay RLB. This relay is energized by the closure of either the pressel or key. To obviate the relay 'chattering' by trying to follow the key operation or similar short breaks in transmission a delay circuit is included which holds the relay operated for a period of 5-10 sec after the pressel or key are released, this circuit is exactly similar to that described in para 257 et seq.

322. It will be seen that when RLB is unoperated, ie receive condition, its contacts RLB1 and RLB2 connect the R.F.A. No 2 and TRA13 batteries in parallel, whereas when RLB is operated the contacts provide a series connection (24V) to the amplifier, the TRA13 supply of course remaining at 12V. In the transmit condition an input filter consisting of L10, C23 and C24 is brought into service.

323. The power amplifier transistors TR1 and TR2 are protected by a thermal relay RLA. Should the temperature of the heat sink exceed 95°C the relay contacts open and disconnect the 24V supply to the transistors. The contacts will remain open until the temperature reduces to a value of 75°C, this time is dependent upon the external ambient but normally is in the range 1/2-3 minutes.

324. When the amplifier is being operated from an external 24V supply (connected to SK4) protection against reverse polarity is provided by D6 and against high transient voltages by the Zener diode D5.

Relay switching

325. The functions of RLA and RLB have already been described in para 321-323.

326. Relay RLC is operated when the amplifier SB is at ON and the key or pressel is depressed. Its contacts RLC1 and RLC2 perform the following functions:

- a. Relay unoperated, r.f. input socket SK2 connected directly to r.f. output socket SK1.
- b. Relay operated, r.f. input socket SK2 connected via RLC2 to the equalizer circuit and amplifier input; the amplifier output is connected via RLC1 to the r.f. output circuit SK1.

327. Relay RLD is operated when the TRA13 is switched to amplitude modulation and 12V appears at pin B on SK5 and SK6. The relay contacts RLD1 and RLD2 connect the appropriate equalizer networks in the amplifier input circuit according to the operating mode selected on the system switch of the TRA13.

Equalizer circuits

328. These are frequency-sensitive parallel T attenuators which provide the correct compensation between the output circuits of the TRA13 and the frequency characteristics of the amplifier.

329. Two networks are provided one to give the correct response under phase modulation or c.w. conditions and the other for amplitude modulation. The approximate Attenuation characteristics are:

Phase modulation: 6.5dB at 2MHz
 3dB at 8MHz

Amplitude modulation: 6dB at 2MHz
 2dB at 8MHz

R.F. amplifier

330. The output from the equalizers is connected via the wideband input transformer T1 to the wideband push-pull amplifier stage (TR1 and TR2). The output from the amplifier is matched to a 50Ω output via the matching transformer T2. The amplifier is linear over the band 1-10MHz and has a minimum power gain of 10dB, negative feedback of approximately 6dB is provided by the 0.5Ω emitter resistors (R12, R14, R13, R15). The resistor combination R18 and R17 is provided to compensate for the production spreads in the various parameters of the power transistors, the important result of this is that the input capacitance presented by the amplifier to the filter sections is substantially constant.

331. The power transistors are liable to damage by:

- a. Excessive voltage transients.
- b. Antenna mismatch.

332. To protect the transistors against rapid transients Zener diodes D1 and D2 are connected in the collector circuits of TR1 and TR2, under conditions of excess voltage the diodes conduct and clip the peaks.

333. In the event of an antenna mismatch the transistors would tend to over-heat, the heat sink temperature would rise causing R1A to operate and disconnect the supply voltage (para 323).

Filters

334. After amplification the signal is passed via T2 to one of three filters dependent upon the operating frequency. These filters corresponding to the frequency ranges 2-3MHz, 3-5MHz and 5-8MHz are designed to ensure good harmonic rejection, the specified rejection level is 30dB with ±0.2dB ripple in the pass band.

335. It will be seen that this is a major difference from the Mk 1 amplifier in that there is no tuning control, it merely being necessary to choose the appropriate band filter.

CHARGER, BATTERY RESISTANCE

BRIEF TECHNICAL DESCRIPTION

General

336. This unit is provided to allow SRA13 batteries to be charged from petrol driven generators such as the 300W and 1260W models.

337. These generators provide voltages of about 36V which are too great for the V.R.U. The unit therefore includes both series resistors to reduce the voltage to the V.R.U. to less than 28 and also a sensing unit which switches in a resistive load for the generator wherever the load reduces below approximately 5A.

338. The charger is designed to cater for up to five V.R.U.s connected to it. With a 300W generator one unit may be connected (five V.R.U.s) whilst a 1260W generator can supply up to three units (15 V.R.U.s).

Construction

339. The unit is constructed on a mild steel angular frame with a steel plate front panel. The rest of the box is enclosed in expanded metal to ensure adequate ventilation.

340. The carrying handles mounted on the front panel are insulated from the panel and also perform the function of bus-bars to which the clips from the V.R.U.s are connected.

Controls

341. The controls are as shown in Fig 44 and Table 8.

Table 8 - Charger, battery resistance, controls

Item	Cct ref	Function
OUTPUT. ON/OFF	S1	Connects output to bus-bars and output terminals
REDUCE VOLTS	S2	Allows the output voltage to be reduced
Meter	M1	Reads output voltage
INPUT terminals		Input voltage from generator
OUTPUT bus-bars		} Output voltage to V.R.U.s
OUTPUT terminals		

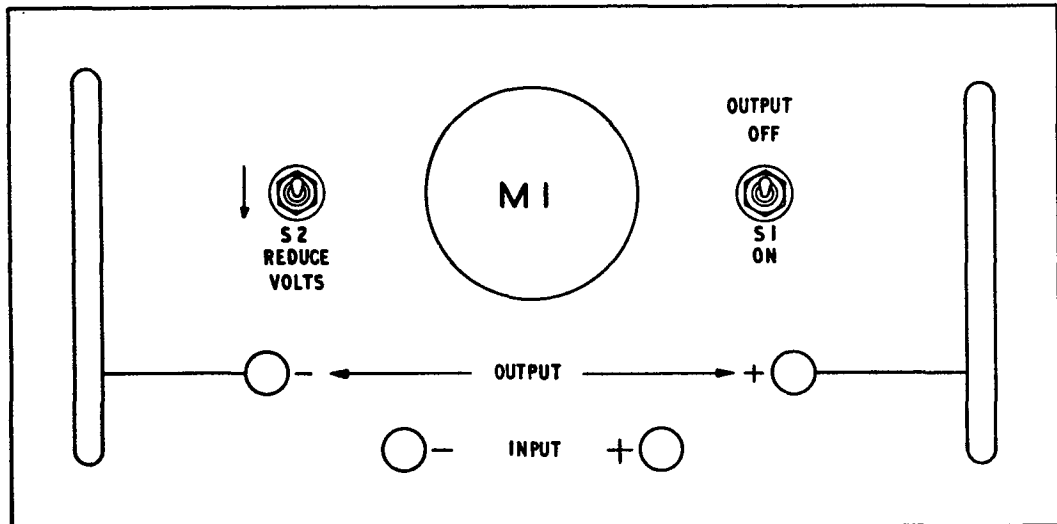

Fig 44 - Charger, battery resistance, controls

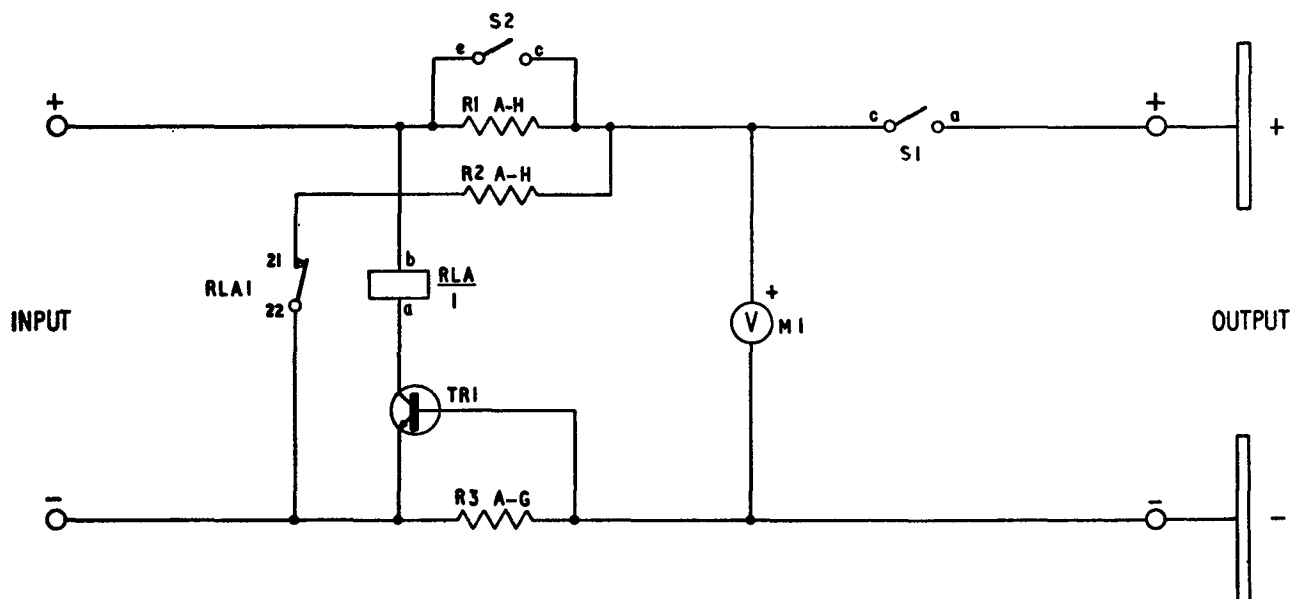

Fig 45 - Charger, battery resistance, circuit

DETAILED TECHNICAL DESCRIPTION

342. With the generator connected to the input terminals and S1 open and S2 closed the generator regulator should be adjusted until the meter M1 reads less than 28V. In some cases this is not possible and S2 is then opened; R1 A-H then provides sufficient voltage drop to bring the voltage below 28.

343. During this setting up procedure relay R1A will be unoperated and the generator will be loaded by resistor bank R2 A-H via R1A1.

344. When S1 is operated, and provided the batteries (V.R.U.s) draw a current in excess of 5A, relay R1A will operate and its contact R1A1 opens removing the regulating load R2 A-H.

345. The relay R1A operates by virtue of transistor TR1. The base bias of this transistor is formed by the battery load impedance and R3 A-G. When the charging current is low (less than 5A) the load impedance is high relative to R3 A-G and TR1 is switched off and relay R1A is unoperated. When the load impedance is reduced the TR1 is switched on and its collector current operates R1A. This action ensures that the generator remains loaded; otherwise, as the batteries become charged and draw less current, the generator tends to rise to a dangerously high voltage and could damage the V.R.U.s.

Note: The next page is Page 1001

SIGNAL FREQ MHZ	CRYSTAL OSC MHZ	1st I.F. KHZ	V.F.O. KHZ	2nd I.F. KHZ	KHZ DIAL
2.0 - 2.5	3.45	1450-950	1905-1405	455	000-500
2.5 - 3.0	3.95				500-1000
3.0 - 3.5	4.45				000-500
3.5 - 4.0	4.95				500-1000
4.0 - 4.5	5.45				000-500
4.5 - 5.0	5.95				500-1000
5.0 - 5.5	6.45				000-500
5.5 - 6.0	6.95				500-1000
6.0 - 6.5	7.45				000-500
6.5 - 7.0	7.95				500-1000
7.0 - 7.5	8.45				000-500
7.5 - 8.0	8.95				500-1000

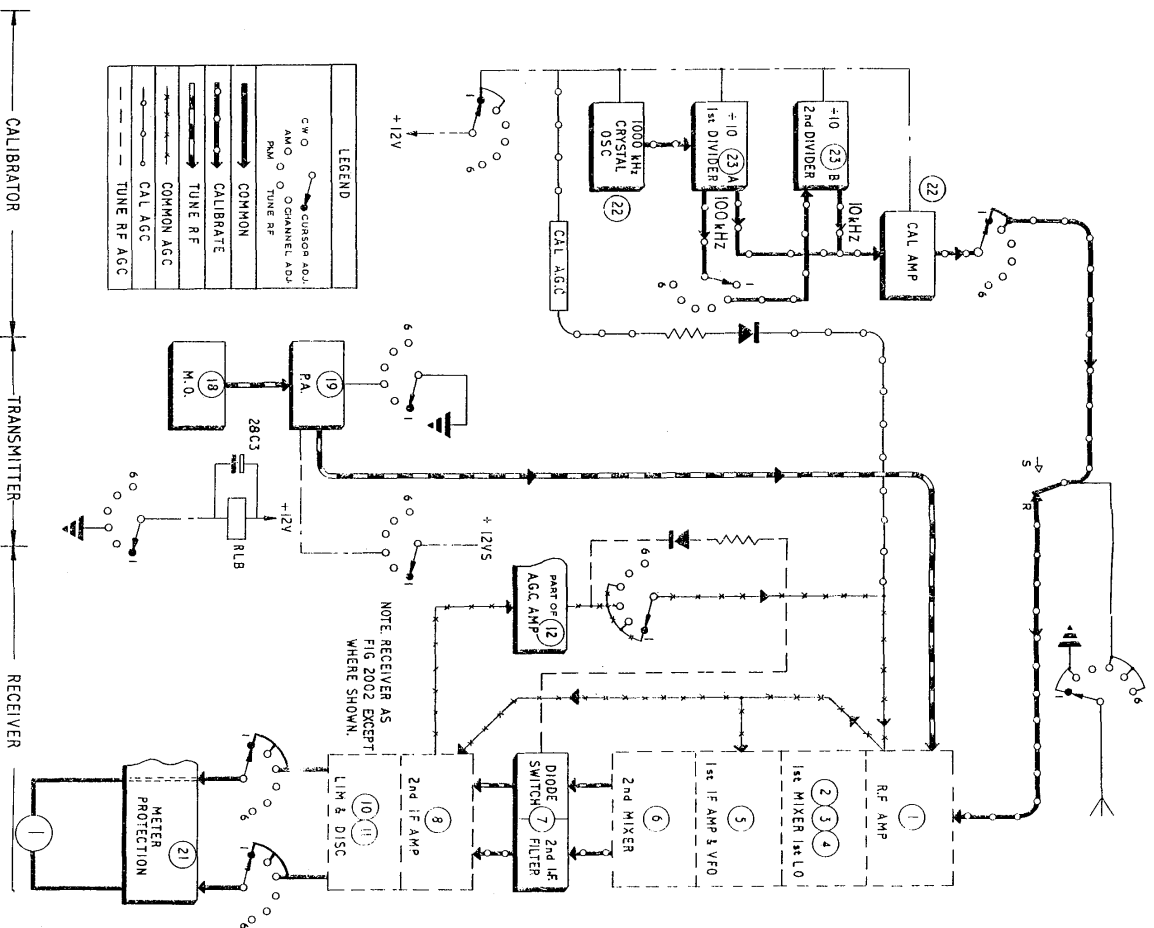

Fig 2001 - TPA13, calibration and tune r.f., block diagram

RESTRICTED

ELECTRICAL AND MECHANICAL
 ENGINEERING REGULATIONS

SIGNAL FREQ MHZ	CRYSTAL OSC MHZ	1st I.F. KHZ	V.F.O. KHZ	2nd I.F. KHZ	KHZ DIAL
2.0 - 2.5	3.45	1450-950	1905 - 1405	455	000 - 500
2.5 - 3.0	3.95				500 - 1000
3.0 - 3.5	4.45				000 - 500
3.5 - 4.0	4.95				500 - 1000
4.0 - 4.5	5.45				000 - 500
4.5 - 5.0	5.95				500 - 1000
5.0 - 5.5	5.45				000 - 500
5.5 - 6.0	6.95				500 - 1000
6.0 - 6.5	7.45				000 - 500
6.5 - 7.0	7.95				500 - 1000
7.0 - 7.5	8.45				000 - 500
7.5 - 8.0	8.95				500 - 1000

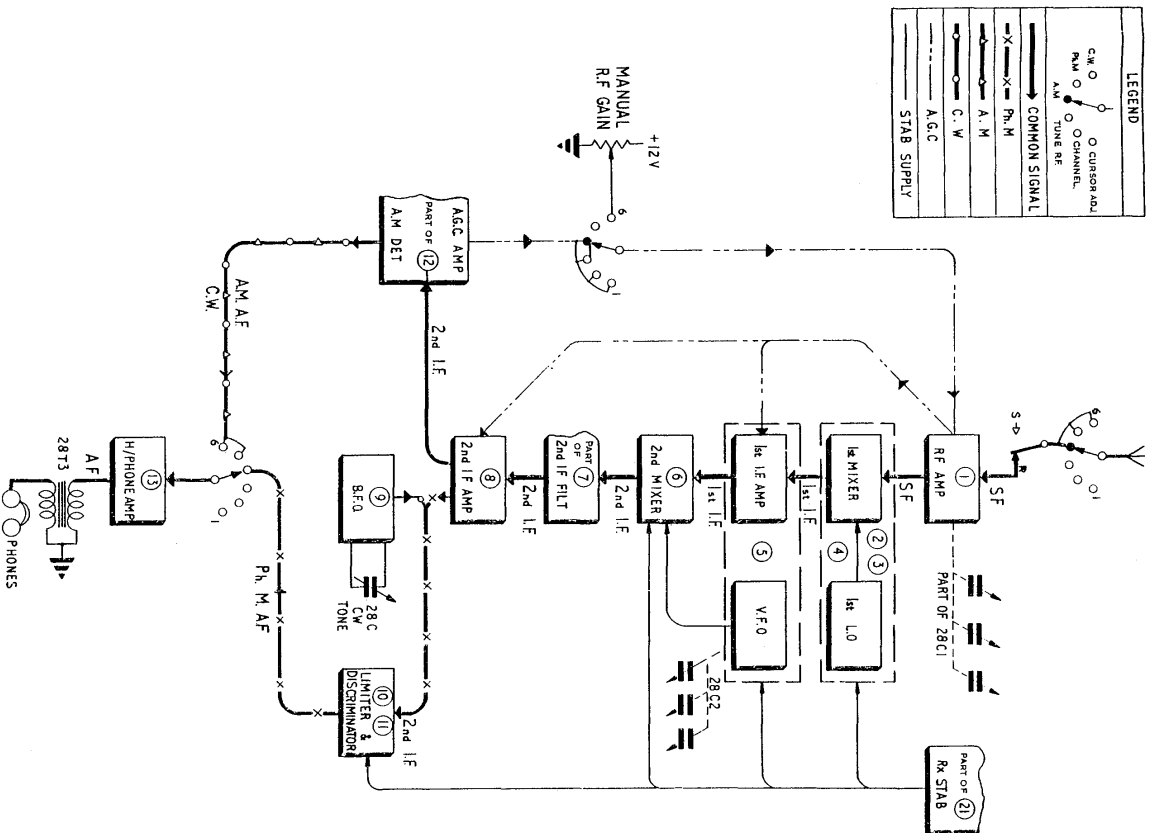

Fig 2002 - TR413, receiver block diagram

RESTRICTED

2185/142

SIGNAL FREQ MHZ	CRYSTAL OSC MHZ	1st LF kHz	VFO kHz	2nd LF kHz	kHZ DIAL
2.0 - 2.5	3.45				000 - 500
2.5 - 3.0	3.95				500 - 1000
3.0 - 3.5	4.45				000 - 500
3.5 - 4.0	4.95				500 - 1000
4.0 - 4.5	5.45				000 - 500
4.5 - 5.0	5.95	1450-950	1905-1405	455	500 - 1000
5.0 - 5.5	6.45				000 - 500
5.5 - 6.0	6.95				500 - 1000
6.0 - 6.5	7.45				000 - 500
6.5 - 7.0	7.95				500 - 1000
7.0 - 7.5	8.45				000 - 500
7.5 - 8.0	8.95				500 - 1000

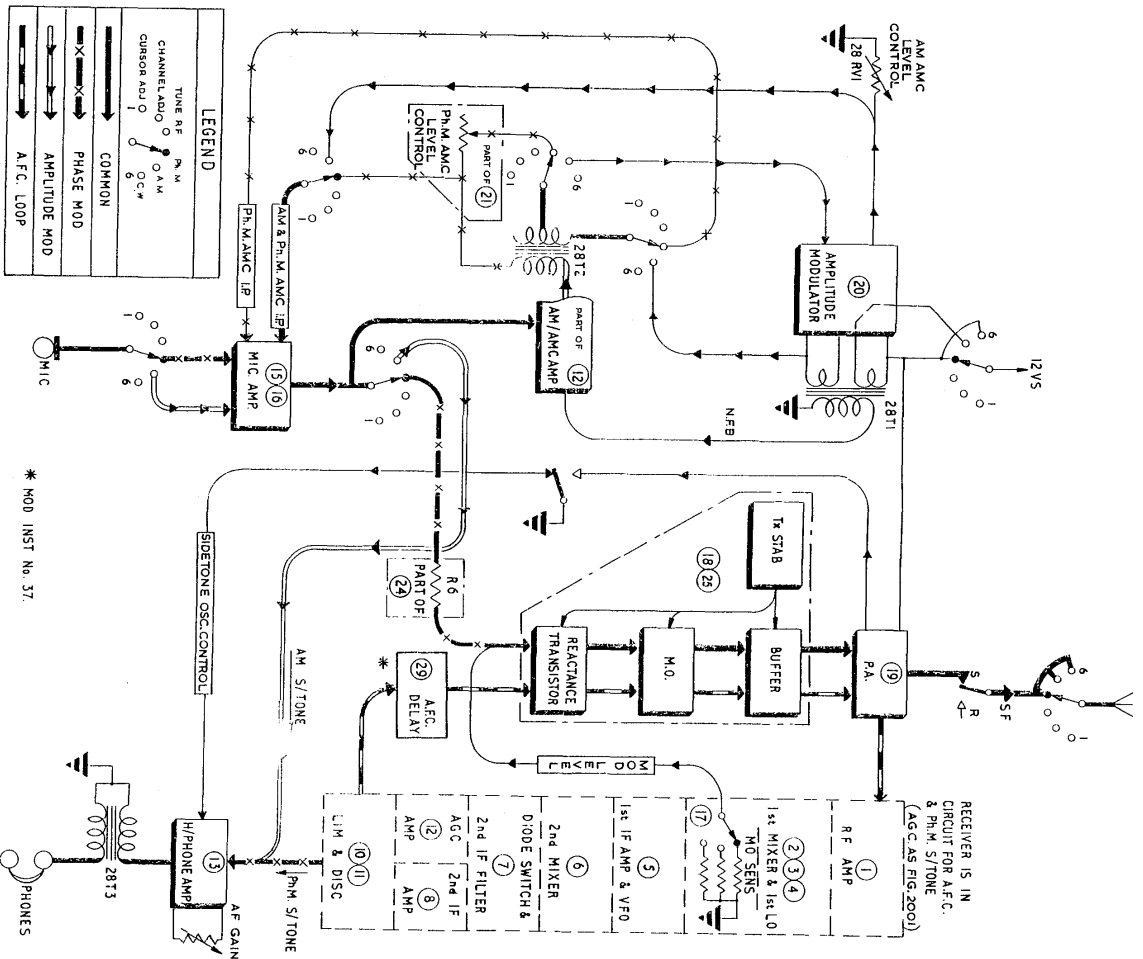

Fig 2003 - TR43, transmitter block diagram

