

WIRELESS STATION NO. 31 AFV

TECHNICAL HANDBOOK - FIELD AND BASE WORKSHOP REPAIRS

SUBJECT INDEX	Para
VOLTAGE ADJUSTMENT	1
SPECIFICATION TESTS	2 - 39
Test equipment	2 - 3
Specification tests on wireless set	4
Receiver quieting	5
Sender power output	6
Specification tests on Power supply and L.F. amplifier unit No. 3	7 - 40
Battery connections and loading	7 - 8
H.T. and L.T. voltage checks	9 - 14
L.F. amplifier on RECEIVE	15 - 17
Microphone amplifier on SEND	18 - 21
Intercommunication amplifier on RECEIVE	22 - 24
Intercommunication with unit switched OFF	25
Hum and suppression	26 - 27
Maintenance of carbon pile regulator	28 - 31
Adjustment of carbon pile regulator	32 - 38
Test panel	39
COIL WINDING SPECIFICATIONS	40 - 43

INDEX TO FIGURES

Fig No.	Page
1 Attenuator for use with Meter, output, power, No. 5	2
2 Method of obtaining variable D.C. supply	5
3 L.F. amplifier - test on receive	7
4 Microphone amplifier - test on send	8
5 Intercommunication amplifier - test on receive	8
6 Voltage regulator	10
7 Voltage regulator - test circuit diagram	11
1001 P.S. and L.F. unit test panel circuit diagram	1001

INDEX TO TABLES

Table No.	Page
1 Equipment required for testing the Power supply and L.F. amplifier unit No. 3	3
2 Voltages and currents of Wireless Station No. 31 AFV	5
3 H.T. and L.T. voltage limits	6
4 Coil winding data for Power supply and L.F. amplifier unit No. 3	12-14

VOLTAGE ADJUSTMENT

1. Before installing the equipment in a vehicle it is necessary to check that the L.T. voltage from the Power supply and L.F. amplifier unit No. 3 is 3.9V when

connected to the Wireless set No. 31 AFV with which it is to be installed. To do this, remove the case from the power supply unit, connect to the Wireless set No. 31 AFV and the necessary batteries, switch on and allow to run for 15 minutes for the carbon-pile regulator to warm up. Measure the L.T. voltage with an Avometer, universal, 40-range, between the chassis and socket SKA-D. If the voltage is not 3.9W exactly, adjust RV1 accordingly.

SPECIFICATION TESTS

Test equipment

2. Test equipment required to maintain the Power supply and L.F. amplifier unit No. 3 is listed in Table 1. With regard to Item 2 therein, the instruments are specified in order of preference. Should only the Meter, output, power No. 5 be available, it will be necessary to use an attenuator in conjunction with it, in order to increase its range. A suitable arrangement is shown in Fig 1; in this case the range is increased twelve times, ie, the indication on the meter will be one twelfth of the total power applied.

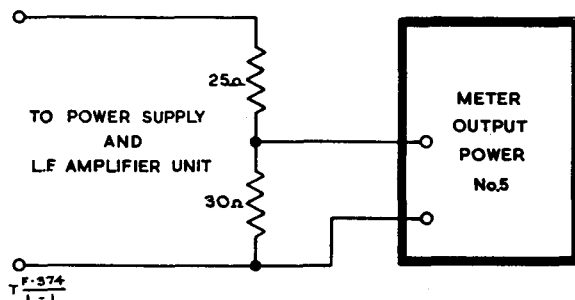

Fig 1 - Attenuator for use with Meter, output, power, No.5

Item No.	Part No.	Description	Qty
1		Avometer, universal, 50-range	1
2		Wattmeter, absorption, A.F., No. 1; Meter, output, power, No. 3, Mk 1 or Mk 2, or Meter, output, power, No. 5 (see para 2)	1
3		Oscillator, beat frequency, No. 5	1
4		Voltmeter, valve, 150V, No. 1 or No. 2	1
5		Voltmeter, range 0 to 50V	2
6	ZA 38824	Transformer, microphone and output assembly No. 1A	1
7		Resistor, variable, wire-wound, 10Ω 50W	1
8	Z 244044	Resistor, wire-wound, 2.7kΩ 15W	1
9	Z 244045	Resistor, wire-wound, 3.0kΩ 4.5W	1
10	Z 215020	Resistor, wire-wound, 13Ω 1.5W selected to give 6.5Ω $\pm 2\%$ in parallel	2
11	Z 215214	Resistor, composition, 560Ω 1W	1
12	Z 217198	Resistor, composition, 510Ω 1W selected for 500Ω	1
13	Z 217665	Resistor, composition, 100Ω 1W	1
14	Z 217625	Resistor, composition, 56Ω 1W	1
15	Z 211071	Resistor, composition, 47Ω 1W	1
16	Z 223007	Resistor, composition, 56kΩ $\frac{1}{2}$ W	1
17	Z 217565	Resistor, composition, 10Ω 1W (Paralleled)	2
		If an Output power meter, No. 5 is used:-	
18	Z 217064	Resistor, composition, 30Ω 1W	1
19	Z 217598	Resistor, composition, 24Ω 1W selected for 25Ω	1
20	Z 241031	Resistor, wire-wound, vitreous, 16Ω 10W (Paralleled)	2
21	Z 243313	Resistor, wire-wound, vitreous, 18Ω 3W (Paralleled)	2
22		Resistor, variable, wire-wound, 9Ω 5W	1

Table 1 - Equipment required for testing the power supply
and L.F. amplifier unit No. 3

3. The test equipment required to maintain the Wireless Station No. 31 AFV is listed in Tels F 364.

Specification tests on wireless set

4. With the exceptions given below the performance figures for the wireless set are the same as those given in Tels F 364. It should be noted that as the aerial coil tapping has been changed to match a 45Ω feeder, the dummy load referred to in the above EMER should NOT be used for sensitivity on R.F. power output tests.

Receiver quieting

5. With the wireless set connected to the power supply and L.F. amplifier unit, connect an output meter (50Ω) across PLB2 and earth. Adjust the volume control until a convenient level of noise, say 100mW , is indicated on the output meter. Apply a C.W. input from a Signal generator, No. 13, (7.5Ω impedance) to the aerial plug via a 33Ω carbon resistor so that the output meter indication is reduced by 20db (1/100th of previous reading). The input required from the signal generator should not be greater than $7.0\mu\text{V}$. If a Signal generator, No. 2, Mk 4 is used (14Ω impedance) the series resistance should be approximately 31Ω .

Sender power output

6. Terminate the aerial plug with a 47Ω carbon resistor and connect a valve voltmeter via its probe across the resistor. With the wireless set switched to SEND (PLB3 connected to earth) the valve voltmeter should indicate not less than 3V on any frequency.

Specification tests on Power supply and L.F. amplifier unit No. 3

Battery connections and loading (Fig 2 and Table 2)

7. It is preferable that the battery voltage to the unit shall be continuously variable over a limited range. This may be achieved by three 12V secondary batteries used as follows:-

Connect the three secondary batteries in series, with a variable resistance of 10Ω (Item 7, Table 1) in the positive lead. The resistance gives a variable supply with respect to PLA-2 on the power supply and L.F. amplifier unit, to cover the range 11 to 15V for 12V equipments and 22 to 30V for 24V equipments, (see Fig 2).

Intercommunication with unit switched off

8. Connect dummy load resistors of $3k\Omega$ (Item 9) and 6.5Ω (Item 10) between pins SKA-C and earth and SKA-D and earth respectively. Note that the values of the load resistors are allowed very little tolerance. It is advisable that when a number of power supply units are to be repaired a test panel is constructed as described in para 39.

H.T. and L.T. voltage checks

9. Switch on the supply, check that it is adjusted to 12 or 24V and adjust RV1 to give 3.9V across SKA-D and earth.

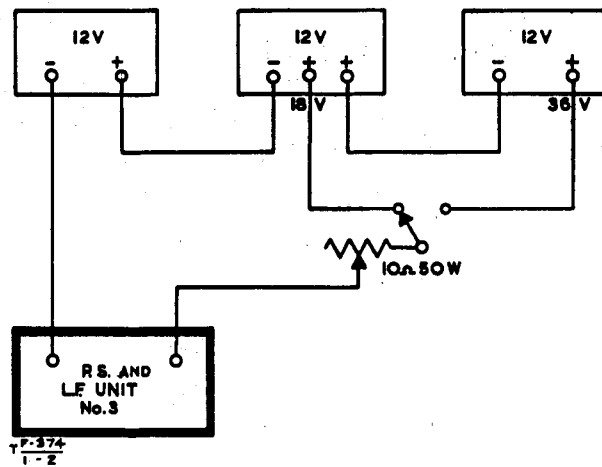

Fig 2 - Variable D.C. supply

10. Leave the supply switched on for 15 minutes and if necessary, re-adjust RW1 so that the L.T. voltage is still 3.9V. Check the input current and filament voltages which should be within the limits shown in Table 2.

Power supply and L.F. amplifier No. 3	Filament voltages:		Min	Max
	V1 - 2.4V			2.8 V
		V2 - 1.2V		1.4 V
Wireless set	Input current:		12V equipment	
	Send		4.2A	
	Receive		3.5A	
			24V equipment	
		Send	3.0A	
		Receive	2.5A	
		Filament current	H.T. current	
Send		600mA	4.7mA	
Receive		600mA	28mA	

Table 2 - Voltages and currents of
W.S. No. 31 AFV

11. Using the test circuit of Fig 2, reduce the input voltage to 11V (or 22V in the case of the 24V equipment) and measure the voltage between SKA-D and earth;

also measure the H.T. voltage across the $3k\Omega$ load resistor. Connect a $2.7k\Omega$ resistor (Item 8) between SKA-G and earth, change from RECEIVE to SEND by short-circuiting PLB3 and 5 and repeat the above measurements. The voltages should be within the limits given in Table 3.

12. Repeat the tests in the previous paragraph with an input of 15V (30V for 24V equipment) increasing the input smoothly by means of the series variable resistor. The voltages should remain within the limits given in Table 3.

Test points	Voltages			
	12V equipment		24V equipment	
	Minimum	Maximum	Minimum	Maximum
L.T. voltage across SKA-D and earth	3.7V	4.2V	3.7V	4.2V
H.T. voltage across SKA-G and earth (HT2)	110V	190V	110V	190V
H.T. voltage across SKA-C and earth (HT1)	66V	130V	66V	130V
H.T. voltage across SKA-G and earth with LK1 at LOW POWER	65V	100V	65V	100V

Table 3 - H.T. and L.T. voltage limits

13. Link the Power supply and L.F. amplifier unit No. 3 to the Wireless set No.31 AFV by means of SKA and check for the correct voltages on the sender and receiver as in Table 3. This final check is essential.

14. Disconnect the Wireless set No. 31 AFV from the Power supply and L.F. amplifier unit No. 3 before proceeding to carry out the tests detailed in paras 15 to 25.

L.F. amplifier on RECEIVE (See Fig 3)

Note: The following tests should be carried out with the load resistors connected as in para 8, the supply voltage being adjusted to exactly 12 or 24V.

15. The output meter of the Oscillator, beat frequency, No. 5, on the 600Ω range is scaled up to 50V. To permit voltages of the required order to be obtained, a simple attenuator is used between the output of the B.F.O. and the circuit under test. Suitable values for an attenuator are given in Fig 3.

16. Connect the B.F.O., with output impedance switched to 600Ω , through the attenuator to SKA-M and earth. Connect an output meter (50Ω impedance) across PLB2 and 5. Adjust the output of the B.F.O. at 1,000c/s to give a reading of 150mW on the output meter. The input should be between 0.85 - 1.3V (ie, 9.3 - 14.3V on the B.F.O. meter).

17. Reduce the input so that an output of 50mW at 1,000c/s is obtained. Alter the B.F.O. frequency to 500c/s and 5,000c/s; with the input constant as for 1,000c/s the output will be between 16 - 50mW and 50 - 155mW respectively.

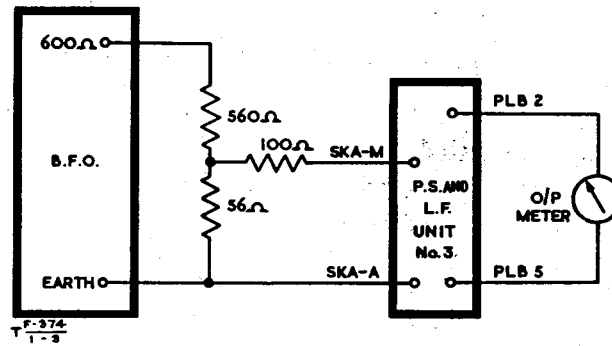

Fig 3 - Attenuator, L.F. amplifier tests

Microphone amplifier on SEND (See Fig 4)

18. Connect the B.F.O., switched to 600Ω , through the attenuator as shown in Fig 4, to pins PLB1 and PLB6 and the valve voltmeter to SKA-K and SKA-D in parallel with the primary of a Wireless set No. 31 microphone transformer, with a $56k\Omega$ resistor connected across the secondary.

19. Connect the $2.7k\Omega$ load between SKA-G and earth and short-circuit pins 3 and 5 of PLB to put the equipment to SEND, connecting up as shown in Fig 4.

20. Apply an input at $1,000c/s$ to give a reading of $320mV$ on the valve voltmeter. The input should be between $30 - 60mV$ (ie $3v - 6v$ on the B.F.O. meter).

21. Repeat the test at $500c/s$ and $5,000c/s$ keeping the input constant at that found in para 20. The results obtained should be as follows:-

- (a) $500c/s$ - valve voltmeter should be within -8 and $-14db$ of the figure obtained in para 20.
- (b) $5,000c/s$ - valve voltmeter reading should be within -2 and $+4db$ of the figure obtained in para 20.

Intercommunication amplifier on
RECEIVE (See Fig 5)

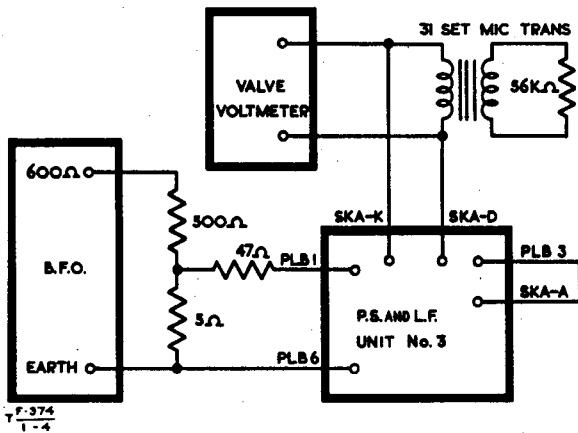

Fig 4 - Microphone amplifier tests

22. Switch the B.F.O. to 600Ω. Feed the output of the B.F.O. through the attenuator arrangement shown in Fig 5 to pins PLB4 and earth; connect the output meter (50Ω) across pins PLB2 and earth. Remove the 2.7kΩ resistor from SKA-G and the short-circuit across PLB3 and earth.

23. Adjust the B.F.O. at 1,000c/s to give 50mW output; the input should be between 0.9 and 1.5V (9.9 - 16.5V on the B.F.O. meter).

24. Repeat the test for frequencies of 500c/s and 5,000c/s for the same input as found in para 23. The output should be between 32 - 79mW in each case.

Intercommunication with unit switched
OFF

25. With the power switched off, check for zero resistance between pins 2 and 4 of PLB. Switch SWab should short-circuit these pins so that the operator is connected to I.C. when the Wireless set No. 31 AFV is switched off.

Hum and suppression

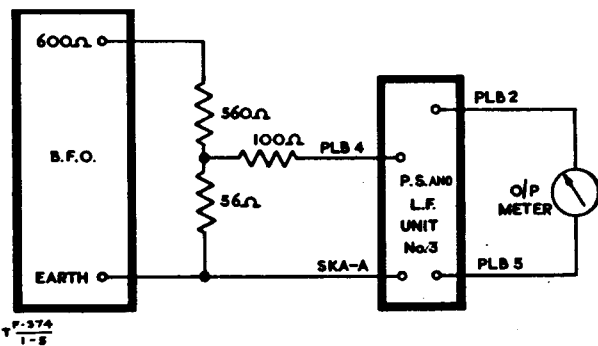

Fig 5 - Intercommunication amplifier
tests

26. The test for receiver quieting given in para 5 should show whether the vibrator suppression circuits are in order, and in general it may be assumed that if this test can be successfully carried out (when the receiver is correctly aligned) the suppression is satisfactory.

27. If Interference measuring sets types RMS1 and FSM22A are available, direct measurements of the efficiency of the suppression may be made. The interfering voltage obtained across the battery terminals by this method should not exceed 100μV between frequencies of 150kc/s to 150Mc/s.

Maintenance of carbon pile regulator

28. The following paragraphs give the procedure for overhauling the carbon pile regulator, but it is emphasized that it must not be removed from the unit until it is definitely established to be at fault.

29. Remove the carbon pile regulator from the equipment, slacken the locking screws and remove the compression screw. Place a stiff rod through the centre holes of the carbon washers and remove the complete pile stack by tilting the regulator. Should the regulator be fitted with solid carbon discs place a sheet of paper on the bench and allow the discs to drop gently out of the ceramic tube. There are 22 carbon washers of 1mm thickness and two of 3mm thickness, all washers being 10.9mm diameter, making up the pile. The two thick ones are at the extremities. Brush the washers lightly with a camel-hair brush to remove any dust adhering to the surfaces and replace any that are damaged or badly fitting. The washers should not be handled unnecessarily.

30. Examine the ceramic tube, clean if necessary and blow with a jet of dry air. Inspect the carbon insert fixed to the armature spring assembly and clean if necessary by lightly rubbing on a piece of close-grained paper placed on a surface plate.

31. To reassemble the regulator, unscrew the core locking ring and turn the core anti-clockwise about three turns. Replace the pile in the ceramic tube. Screw the cooler on until the spring of the armature assembly is fully compressed, ie it is fully wrapped on the bi-metal support. Care must be taken not to use undue pressure during this operation otherwise damage to the carbon pile will result.

Adjustment of regulator (See Fig 7)

32. Turn the core clockwise until it comes into contact with the armature assembly, ie no gap position. Now slacken the pile compression screw by three-quarters of a turn and lock.

33. Check the voltage coil and ballast resistor for continuity. Connect the voltage regulator to the test circuit shown in Fig 7. Short-circuit the pile and apply a switched 15V supply across the voltage coil and ballast resistor. Switch this on and off at least three times. Remove the short-circuit from the carbon pile.

34. With an input of 13.5V the output read on meter V1 should be 7V and meter A1 should read between 0.55 and 0.65A; if this is not so, adjust the core slightly to obtain this, readjusting ballast resistor to maintain an output of 7V.

35. Slacken the pile compression locking screws and with an input of 17V rotate the pile compression screw clockwise keeping a careful watch on V1. If the voltage decreases, continue to turn until the voltage reaches a minimum and begins to rise again. The correct setting is at this minimum voltage position, which gives optimum regulation. Should the voltage rise on turning the pile compression screw, rotate it in an anti-clockwise direction to find the minimum position. Tighten the locking screws. Adjust the ballast resistor to give exactly 7V output with an input of 13.5V. Provided that the cooler is adjusted to the minimum position and that the controlled voltage is correct and the operating coil current within the limits specified, the regulator will operate satisfactorily.

36. Test the operation of the regulator by running it for not less than 15 minutes with an input of 16V. Before the regulator has time to cool, vary the input voltage

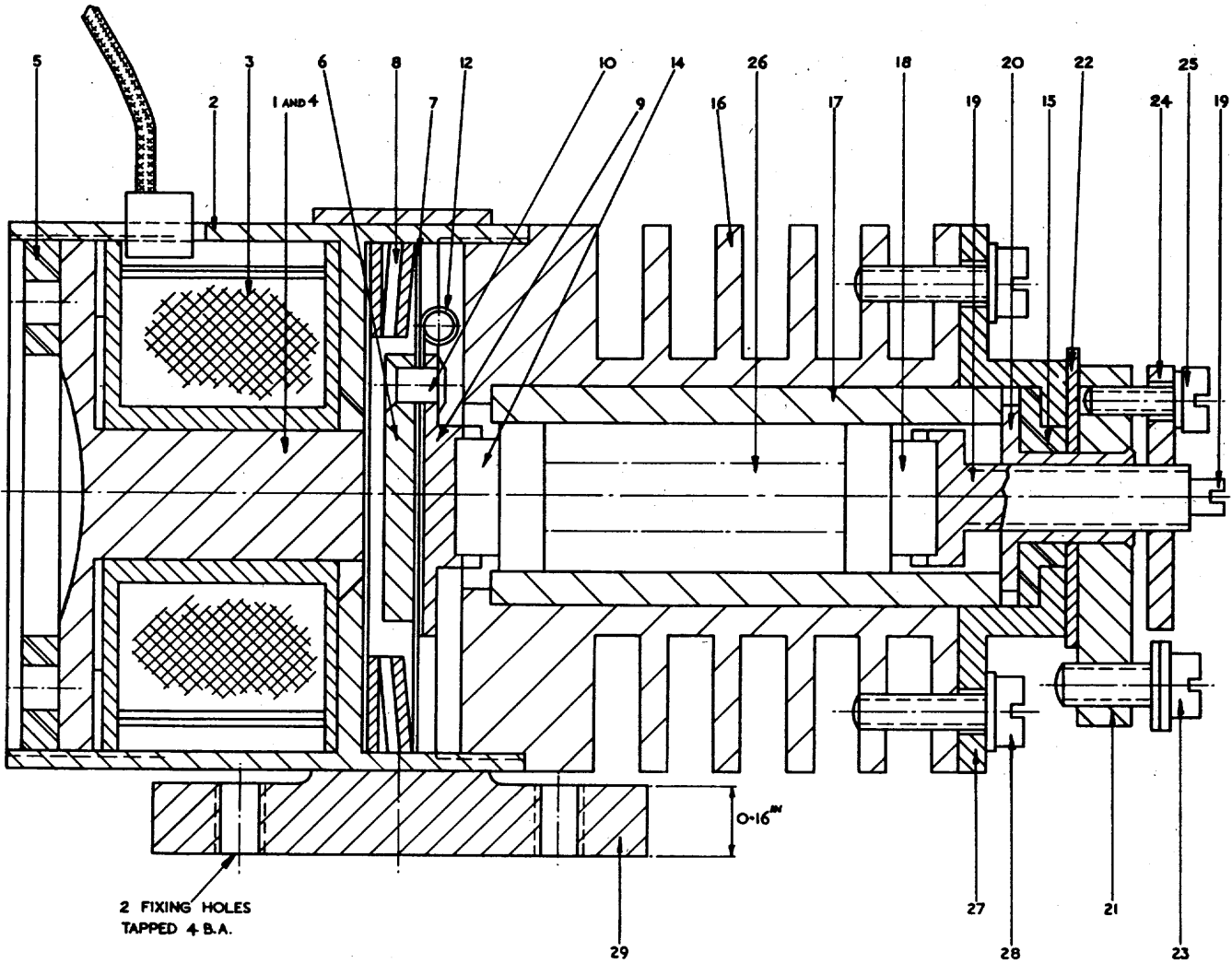

- | | | | | |
|-----------------------|------------------------|---------------------------------|---------------------------------|----------------------------------|
| 1. ENDPLATE | 7. ARMATURE SPRING | 13. ARMATURE FLEXIBLE CONNECTOR | 19. ADJUSTABLE PILE COMPRESSION | 25. LOCKING SCREWS |
| 2. MAGNET CASE | 8. BI-METAL SUPPORT | 14. CARBON TERMINAL PLUG | 20. BRASS FERRULE | 26. CARBON PILE |
| 3. OPERATING COIL | 9. FERRULE | 15. FERRULE INSULATION | 21. CONNECTOR | 27. DISSIPATOR END |
| 4. MAGNET CORE | 10. ARMATURE RIVET | 16. HEAT DISSIPATOR | 22. INSULATION WASHER | 28. DISSIPATOR END FIXING SCREWS |
| 5. CORE LOCKING PLATE | 12. ARMATURE CONNECTOR | 17. CERAMIC TUBE | 23. CONNECTOR SCREW | 29. SUPPORT BRACKET |
| 6. ARMATURE | | 18. CARBON TERMINAL PLUG | 24. LOCKING PLATE | |

T F-374
1-6

Fig 6 - Voltage regulator

smoothly and continuously between limits of 11 and 16V and note that the output voltage is maintained at 7V $\pm 5\%$.

37. To check the stability of the regulator, adjust the input voltage to 17V and switch on and off at least three times. The regulator should respond without tendency towards hunting (ie it must be critically damped). A pair of phones connected across the pile should be used to check this.

38. When the above tests have been completed, the carbon pile regulator should be replaced into the Power supply and L.F. amplifier No. 3 and checks made of the supply voltages as laid down in para 9 - 12.

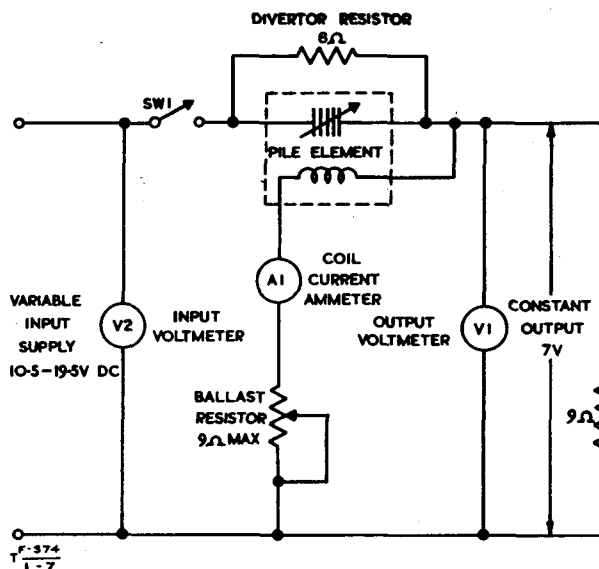

Fig 7 - Voltage regulator test circuit diagram

39. A circuit diagram of a test panel suitable for quantity testing of Power supply and L.F. amplifier units No. 3 is given in Fig 1004. This may be made up on the lines of the test panel given in Tels F 664.

COIL WINDING SPECIFICATIONS

40. Unless otherwise stated the following processes for impregnation etc will be given to all the transformers and chokes:-

- Impregnation : Bitumen varnish, Symite S.475
- Enveloping coat: Two $2\frac{1}{2}$ second dips with an interval of 1 second in Berry Wiggins Kingsnorth 1202 at $135^{\circ} - 140^{\circ}\text{C}$.

41. Testing conditions for vibrator transformers TR1 (12V and 24V) are as follows:-

- (a) Breakdown test voltage for all windings 2,000v. R.M.S.
- (b) No load voltage test; with 175 - 185v. A.C. at 50c/s applied to terminals 3 and 4 the voltage across terminals 6 and 7 or 7 and 8 should be between 8.95 - 9.4V for the 12v equipment and between 18.9 - 19.9V for the 24V equipment.

Wireless set

42. Coil winding data is altered only in respect of L1. This is wound as in Tels E 364 para 44 except that the aerial tapping is made at one $\frac{1}{4}$ turn from the H.T. end.

Power supply and L.F. amplifier unit No. 3

43. L1 No. 20 S.W.G. enamelled copper wire close wound, to fill chamfered section of former. Ends soldered to spills. The winding given one coat of Distrene lacquer.

L2 and L5 No. 36 S.W.G. enamelled copper wire, wound to full length on a $1M\Omega$ $\frac{3}{4}W$ resistor, Z223165. Ends soldered to resistor leads.

The whole given a coating of bakelite varnish.

Table 4 - Coil winding data for Power supply
and L.F. amplifier unit No. 3

Ref	Wire	No. of turns	Turns per layer	No. of layers	Inter-layer insul.	Winding insul.	D.C. resist	Ind	Term connect
L3 and L4	No. 34 S.W.G. nylon covered	2,300	98	24		6 layers of 0.002 inch paper 3 layers 0.015 inch cotton tape	93-114	4.4H	2 and 4
L6	No. 20 S.W.G. D. nylon covered	70	12	6		6 layers 0.002 inch paper 3 layers 0.015 inch cotton tape	0.094-0.141 Ω	3.5mH	2 and 4

Table 4 (contd)

Ref	Wire	No. of turns	Turns per layer	No. of layers	Inter-layer insul.	Winding insul.	D.C. resist	Ind	Term connect
TR1 12v Pri 1st Sect	No. 20 S.W.G. nylon covered	74	34	3	1 layer 0.002 inch paper	6 layers 0.002 inch paper	0.207- 0.253Ω		6 and 7
	No. 36 S.W.G. nylon covered	2900 tap 1450	135	22	1 layer 0.002 inch paper	6 layers 0.002 inch paper	220- 270Ω		2 and 4 tap 3
	No. 20 S.W.G. nylon covered	74	27	3	1 layer 0.002 inch paper		0.315- 0.385Ω		7 and 8
Overall insulation 5 layers 0.015 inch cotton tape									
TR1 24v Pri 1st Sect	No. 22 S.W.G. nylon covered	148	43	4	1 layer 0.002 inch paper	6 layers 0.002 inch paper	0.67- 0.82Ω		6 and 7
	No. 36 S.W.G. nylon covered	2450 tap 1225	135	19	1 layer 0.002 inch paper	6 layers 0.002 inch paper	184- 226Ω		2 and 4 tap 3
	No. 22 S.W.G. nylon covered	148	35	5	1 layer 0.002 inch paper		1.44- 1.76Ω		7 and 8
Overall insulation 5 layers 0.015 inch cotton tape									
TR2 Pri	No. 42 S.W.G. nylon covered	3200	184	18		6 layers 0.002 inch paper	535- 644Ω		2 and 4
	No. 30 S.W.G. nylon covered	360	64	6		6 layers 0.002 inch paper	7.6- 9.3Ω	17.5H	1 and 5
Overall insulation 3 layers 0.015 inch cotton tape									

Table 4 - (contd)

Ref	Wire	No. of turns	Turns per layer	No. of layers	Inter-layer insul.	Winding insul.	D.C. resist	Ind	Term connect
TR3 Pri	No. 46 S.W.G. nylon covered	3800	125	31	1 layer 0.0005 inch paper	4 layers 0.002 inch paper	818- 998Ω		5 and 6
Sec	No. 46 S.W.G. nylon covered	1900	125	16	1 layer 0.0005 inch paper	4 layers 0.002 inch paper	594- 726Ω		7 and 8
TR4 Pri	No. 33 S.W.G. nylon covered	37		1		4 layers 0.002 inch paper	0.36- 0.44Ω		1 and 2
Sec	No. 44 S.W.G. nylon covered	740	100	8	1 layer 0.0005 inch paper	4 layers 0.002 inch paper	80- 100Ω		3 and 4
TR3 and TR4 assembled in a single case and filled with LPRM3 wax at 125°C.									
TR5 Pri	No. 44 S.W.G. nylon covered	1650	118	14	1 layer 0.0005 inch paper	4 layers 0.002 inch paper	176- 264Ω		5 and 6
Sec	No. 39 S.W.G. nylon covered	85	75	2	1 layer 0.001 inch paper	4 layers 0.002 inch paper	4.8- 7.2Ω	4.2H	7 and 8
TR6 Pri	No. 33 S.W.G. nylon covered	37				4 layers 0.002 inch paper	0.36- 0.44Ω		1 and 2
Sec	No. 46 S.W.G. nylon covered	4500	125	37	1 layer 0.0005 inch paper	4 layers 0.002 inch paper	1125- 1375Ω	8H	3 and 4
TR5 and TR6 assembled in a single case and filled with LPRM3 wax at 125°C.									

The next page is Page 1001

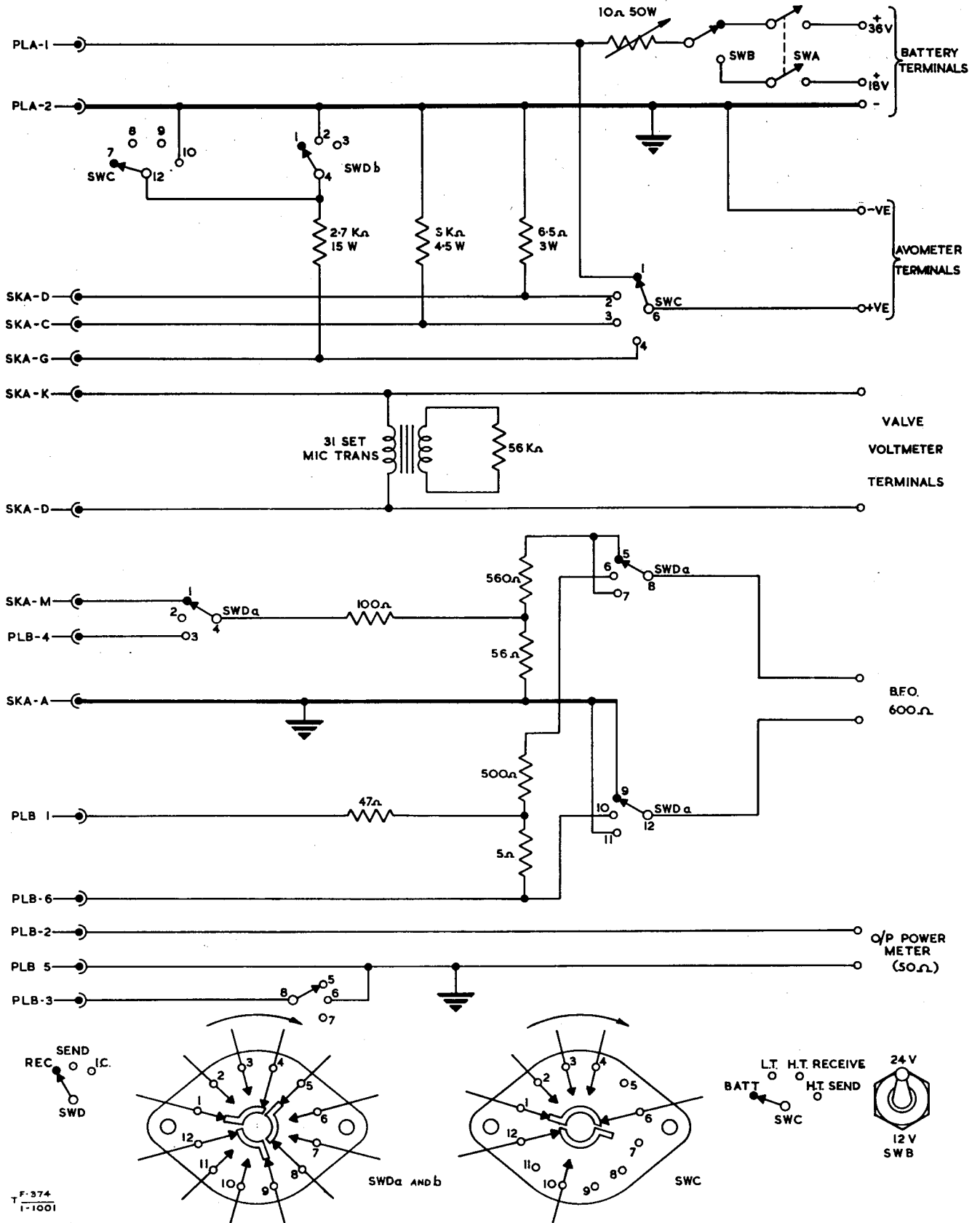

Fig 1001 - Power supply and L.F. amplifier unit, test panel circuit diagram

57/Maint/5366

END

