

The VMARS Archive

VMARS is a not-for-profit organisation specialising in all types of vintage communications electronics. We maintain an archive of documentation to help our members understand, research, repair and enjoy their vintage radio equipment. Access by non-members is extended as a gesture of goodwill, but not as a right.

Rare documents are frequently provided free of charge by VMARS members, and all scanning and document processing is carried out on a voluntary basis. Accordingly, we do not expect others to profit from the hard work of volunteers, who give their time freely without charge.

This is a gentle reminder that the document attached to this notice is provided to you for your personal use only. This edition remains copyright of VMARS, and while you may sell or give your copy to someone else, this right does not extend to making further copies of this information, either to give or sell to others. This includes a prohibition on placing it on websites, or printing it for sale at rallies, boot fairs or similar public events. If our goodwill is abused, then withdrawal of public access to our archive will be the result.

Please refer anyone else wanting a copy back to VMARS – either to our website at <http://www.vmars.org.uk/> or by email to the Archivist at archivist@vmarsmanuals.co.uk. If you want to know more about our copyright, please see the FAQ below.

FAQ on copyright of VMARS documents

- Q** How can you copyright a document that is already in the public domain?
- A.** *Plainly the original copyright of the content has expired, or we have obtained permission to copy them. What we copyright is our own edition of the document.*
- Q.** Surely your “own edition” is identical to the original document, so cannot be copyrighted?
- A.** *Our editions are **not** identical to the original document. You will find that full advantage has been taken of electronic publishing facilities, so pages are cleaned up where possible (rendering them better than originals in some cases!), and large diagrams are prepared for both on-screen viewing and for easy printing at A4 format.*
- Q.** Why do you not just give your manuals away, as so many do via the internet these days?
- A.** *We do make all our manuals available free of charge (in soft copy) to VMARS members. These members have already covered the costs of running the archive via their subscriptions. The only time members are charged for copies is when they request them on paper, in which case charges are restricted to the cost of paper, ink and postage.*

The VMARS archive is not a “shoe-string” operation. Money is spent on computing facilities to make copies available, and on shipping original documents securely (usually costing several pounds per shipment) to carry out the scanning. As members have already contributed to these costs, it is only reasonable that non-members should do likewise – and thus a very moderate charge is levied for copies provided to non-members. With typical commercial photocopying charges starting at 5 pence per A4 side, it will be evident that paying 4 pence for our equivalent on paper is excellent value (amounts current at Spring 2004). We also think “you get what you pay for” – we invite you to make the comparison and draw your own conclusions!

Despite the above, we will be making copies of essential technical information (circuit diagram, parts list, layout) freely available to all via our website from late 2004 onwards. This will be done to try and encourage and enable the maintenance of our remaining stock of vintage electronic equipment.

Guidance on using this electronic document

Acrobat Reader version

You need to view this document with Acrobat Reader **version 5.0** or later. It is possible that the document might open with an earlier version of the Acrobat Reader (thus allowing you to get this far!), but is also likely that some pages will not be shown correctly. You can upgrade your Acrobat Reader by direct download from the internet at <http://www.adobe.com/products/acrobat/readermain.html> or going to <http://www.adobe.com/> and navigating from there.

Printing the document on A4 paper

You should note first that virtually all original documents are in double-sided format, i.e. printed on both sides of the paper. Accordingly, our copies are similarly double-sided., and the best results are obtained if the document is printed double-sided. You can print out on one side only, but you will find that you get a number of blank sheets (which can just be removed and reused), and where margins vary in width between left-hand and right-hand pages, there is a danger of the text disappearing into the binding of your printed copy.

This document is of fairly simple format in that it can be made to print out using an A4 format printer (this is the common paper size available in UK and Europe, which measures 29.7cm by 21.0cm). By “simple” I mean that there are no large diagrams on fold out sheets, which will require multiple A4 pages to print out at full size.

Original document sizes do vary a lot – from the small manuals, which approximate to A5 size (21.0 x 14.8 cm) up to the now obsolete foolscap size (21.6 x 33.0 cm). US documents tend to use their “letter” size paper (21.6 x 27.9 cm). All these sizes can be printed on A4 paper by simply getting Acrobat to shrink or enlarge the pages as necessary. This is done as follows:

1. Select “File – Print” or click on the printer icon. This will bring up the print dialog box.
2. Select the correct printer if necessary.
3. Select the pages you want to print – even if you want to print all of the document, you will probably not want to print this notice and help page, so start the printing at page 3.
4. In the “Page Handling” area, next to “Page Scaling”, select “Fit to paper”. The press “OK”

Printing the document on an US Letter format printer

Since A4 and US Letter sizes are similar, it is expected that this document should print satisfactorily on the latter format paper. This has not been tested however, and is not guaranteed. Follow the steps as for A4 printing, and make doubly sure that “Fit to paper” is selected (step 4).

Any other problems?

Please get in touch with me at archivist@vmarsmanuals.co.uk.

Richard Hankins, VMARS Archivist, Summer 2004

CONDITIONS OF RELEASE

(To be applied to documents which the recipient Government may not release to anyone outside its Defence Departments).

- a. This information is released by the UK Government to the recipient Government for Defence purposes only.
- b. This information must be accorded the same degree of security protection as that accorded thereto by the UK Government.
- c. This information may be disclosed only within the Defence Departments of the recipient Government, except as otherwise authorized by Ministry of Defence (Army).
- d. This information may be subject to privately owned rights.

UK/PRC-316

TECHNICAL HANDBOOK - FIELD AND BASE REPAIRS

This EMER must be read in conjunction with Tels F 202 Part 2 which contains figures and tables to which reference is made

CONTENTS

	<u>Para</u>
INTRODUCTION	
General	1
Scope of repairs	5
GENERAL REPAIR INSTRUCTIONS	
Drying and sealing	8
General precautions	14
MECHANICAL REPAIRS AND ADJUSTMENTS	
Replacement of transmitter r.f. panel assembly and associated components	17
To change board F1	18
To change board F2	19
To change board F3	20
To change the 100Ω antenna terminals TP1 and TP2	21
To change meter	22
To change the 50Ω antenna socket SK2	23
To change front panel	24
To change board F4	25
To change main case assembly and associated components	26
To change key assembly	27

CONTENTS - (cont)

	<u>Para</u>
To replace control panel	32
To replace crystal cassette (J)	33
To replace offset unit (D)	34
To replace receiver a.f. board (E)	35
To replace r.f. board (A)	36
To replace i.f. amplifier (C)	37
To replace 2nd mixer board (B)	38
To replace 300Hz filter	39
Repainting	40
<u>SPECIFICATION TESTS</u>	
General	41
Test conditions	43
<u>Receiver tests class A</u>	
<u>Sensitivity</u>	
C.W. narrow	49
C.W. wide	51
R.T.	53
<u>A.F. output</u>	
C.W. narrow	55
C.W. wide	57
R/T	59
Gain control range	61
A.F. response (RT)	63
Selectivity	65
<u>Transmitter</u>	
R.F. power output and transmitted frequency accuracy	67
Modulation sensitivity and distortion	69
A.F. response	71
Sidetone	73
C.W. operation	75
High speed keying operation	77
Mismatch	79
Antenna current meter	81
Battery meter	83
<u>ADJUSTMENTS AND ALIGNMENT</u>	
Preliminary	85
Tuning voltage coverage	87
Offset oscillator	89
Crystal cassette	90
1st i.f. (L7. L8) alignment	93
R.F. amplifier low band alignment	96
R.F. amplifier high band alignment	99
Offset unit Tx drive mixer T3, alignment	103
455kHz oscillator	104
Transmitter frequency setting and checks	105
<u>ADAPTOR UNIT KEYER INTERFACE - 316</u>	
<u>MECHANICAL REPAIRS AND ADJUSTMENTS</u>	
Removal of panel electronic circuit	106
Removal of plugs and sockets	107

CONTENTS - (cont)

	<u>Para</u>
SPECIFICATION TESTS	
Test conditions	108
Functional tests	
Current consumption	111
Output voltages	113
Keying test	115
SKT1 and SKT2 check	117
REMOTE BATTERY ADAPTOR	
General	119
Functional tests	
Input current with no load	120
Output voltage on load	122
Over voltage protection	124
Reversed polarity protection	126

FIGURES

<u>Fig</u>		<u>Page</u>
1	Sequence for tightening case screws	5
2	Details of c.w. key	9
3	Layout of test equipment	15
4001	Details of combined meter and key spanner	1001

TABLES

<u>Table</u>		<u>Page</u>
1	Test equipment schedule	14
2	Receiver a.f. response	20
3	Modulation sensitivity	23
4	Transmitter a.f. response	24
5	Sidetone	25
6	Battery meter readings	27
7	R.F. amplifier typical tuning volts/frequency table	30
8	Standard loads for adaptor unit keyer interface	32
9	Current consumption	33

INTRODUCTION

General

1. The information contained in this regulation deals with the repair, adjustment and testing of the RT316 in its entirety. Details of the repair and testing of repairable sub-units (CENTREMS) will be issued only to the nominated workshop supplied with the special-to-type test equipment.
2. Testing is based on the use of the Test kit, radio station UK/PRC316 which is separately described in EMER Tels M 362. Table 1 of this regulation details all the test equipment required.
3. Fault finding to a sub-unit may be assisted by reference to EMER Tels F 202 Part 2, Figs 2501, 2502 and 2503.
4. Test points at which the battery voltage may be measured for various switch settings are listed in Tels F 202, Part 2, Table 2514.

Scope of repairs

5. Unit repairs will be confined to those which do not entail the opening of the sealed set, no internal repairs are to be attempted. Full details of permitted repairs are given in EMER Tels F 203.
6. Field repairs will normally be confined to replacement of faulty sub-units, the exchange of components which are not mounted on exchangeable sub-units and alignment and specification testing. Those faulty sub-units which are to be returned to Base workshop for repair and those which are to be discarded are nominated in Tels F 202, Part 1, paras 7-9.
7. Base repairs, which will be carried out by a nominated workshop, will be as for Field repairs, but with the addition of repair of faulty sub-units.

GENERAL REPAIR INSTRUCTIONS

Drying and sealing

8. On receipt for repair the set is to be pressurised to 5 lbf/in² and dip tested in a water tank using a small amount of wetting agent if available. This should reveal any leaky spindle seals, gaskets, rivets and securing screws. The inspection must be thorough, with the set immersed for at least five minutes.
9. Dry externally, then open the set in the driest possible conditions. Carry out functional checks and all necessary repairs and adjustments.
10. Place the opened set in the dehumidifier and dry for at least one hour at 50°C (EMER Tels M 601 gives operating instructions for the dehumidifier). After cooling, the set must be electrically tested and aligned if necessary. The set should then be replaced in the dehumidifier and dried for a further 15 minutes.

11. Before re-sealing the set into its case fit two new silica-gel desiccators (Z1/4440-99-193-5577) and smear the sealing gasket with grease XG271. The case securing screws must be tightened, using a torque wrench, to 5 lbf in. in the order shown in Fig 1.

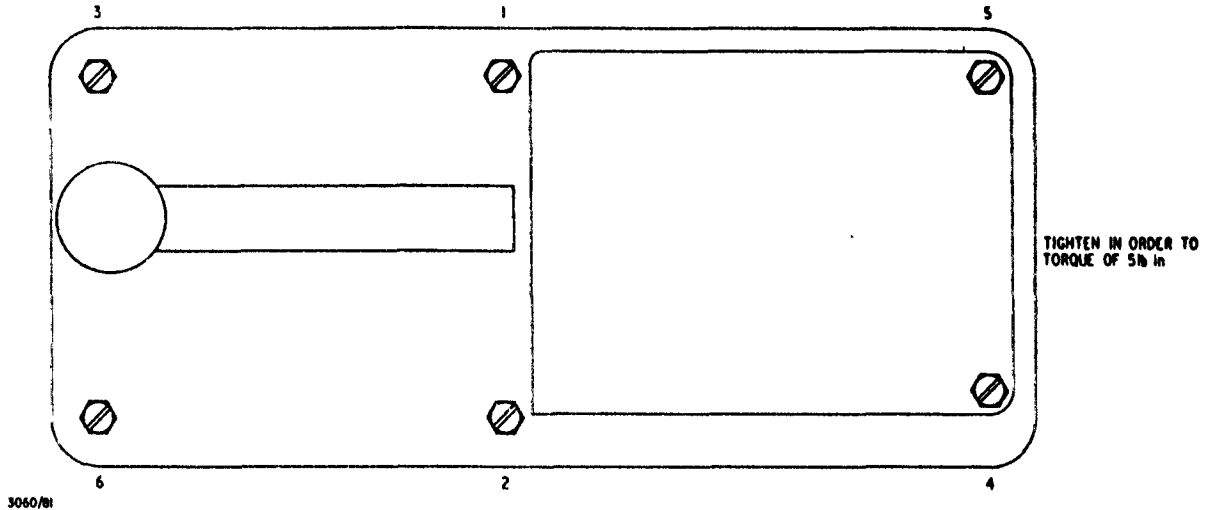

Fig 1 - Sequence for tightening case screws

12. Remove the seal testing plug and fit the appropriate adaptor from the leak locator.

13. The set must now be pressurised to 5 lbf/in² using dry air from the dehumidifier. After 40 minutes the pressure shall not be less than 4.5 lbf/in².

General precautions

14. When reassembling the set the basic channel knob must be set to the unmarked position and the offset knob set at '0'. The gears on the offset and crystal units must be correctly positioned, ie the yellow spot on the gear aligned with the yellow spot on the unit. The cableforms must be placed in their correct positions and care taken that wires are not trapped when the case is assembled.

15. When the set is opened for repair the control panel and chassis assembly should be held in the spreader frame (part of Test kit RT316). A 16-way connector is provided for the electrical connections between the two parts of the set. The knobs on the spreader frame must be correctly aligned as for the knobs on the set (Note: On the spreader frame the basic channel knob does not have an unmarked position, it should therefore be set to the 10 position).

16. Particular care must be taken when making soldered joints. The technique outlined in EMER Tels A 414 must be adhered to. It is essential that a temperature controlled soldering iron with a 370°C Weller tip bit be used on the RT316, Fig 7 of Tels A 414 lists appropriate bits.

MECHANICAL REPAIRS AND ADJUSTMENTS

Replacement of transmitter r.f. panel assembly and associated components

17. Remove the four securing screws and carefully separate the panel assembly from the main case assembly. It is not necessary to completely remove all the boards when changing a faulty one, and by using the following instructions unsoldering and resoldering can be kept to a minimum.

To change board F1

18. a. Unsolder all connections to the board, carefully noting the identification of each wire as it is removed.
- b. Remove the two screws securing F1 bracket to the front panel and remove the board.
- c. Fit new board, using the reverse procedure.

To change board F2

19. a. Remove board F1, see para 18.
- b. Unsolder all connections to board F2, carefully noting the identification of each wire as it is removed.
- c. Remove the two remaining screws which secure F2 bracket to the front panel and remove the board.
- d. Fit new board, using the reverse procedure.

To change board F3

20. a. Unsolder all connections to the board, carefully noting the identification of each wire as it is removed.
- b. Remove the two No 2 BA nuts and washers securing the board to the front panel, remove the board and discard.
- c. Fit new board, using the reverse procedure.

To change the 100Ω antenna terminals TP1 and TP2

21. a. Remove the two No 2 BA nuts and washers securing board F3.
 - b. Carefully ease the board clear of the threaded studs of the terminals to gain access to the nuts securing the terminals to the front panel.
 - c. Remove the securing nut and washer, withdraw terminal and discard.
 - d. Fit new terminal, using the reverse procedure.

To change meter

22. a. Unsolder the black wire which goes to the earth tag on SK2, from the PA earth tag A on board F2.
 - b. Remove the screws securing boards F1 and F2 to the front panel.
 - c. Carefully ease both boards clear of the front panel to gain access to the back of the meter.
 - d. Unsolder the leads to the meter.
 - e. Unsolder the green and black leads which go to board F3, from SK2.
 - f. Remove the two No 2 BA nuts and washers securing board F3 to the front panel and withdraw boards F1, F2 and F3 clear.
 - g. Using the meter removal tool (detail in Fig 4001) remove the meter.
 - h. Fit new meter, using the reverse procedure.

To change the 50Ω antenna socket SK2

23. a. Carry out the operations detailed in para 22.a. to f.
 - b. Remove the nut securing SK2, withdraw the socket and discard.
 - c. Fit new socket, using the reverse procedure.

To change front panel

24. a. Carry out the operations detailed in para 22.a. to g.
 - b. Remove SK2.
 - c. Remove TP1 and TP2.
 - d. Reassemble components and boards to new front panel.

To change board F4

25. a. Unsolder all connections to the board, carefully noting identification of each wire as it is removed.
- b. Remove the three No 6 BA nuts securing the board to the main chassis, remove the board and discard.
- c. Fit new board, using the reverse procedure.

To change main case assembly and associated components

26. Release the six screws securing the control panel to the main case assembly and carefully separate the control panel from the main case. On reassembly, observe the precautions detailed in para 14.

To change key assembly
(Fig 2)

27. The key assembly is issued mounted on a transit plate. The instructions covering the removal of the key assembly from the set also cover the removal of the replacement item from its transit plate.

Removal of key assembly

28. a. Unscrew and remove the cap, nut and washer (1).
- b. Unsolder the two black wires from the plate and stud assembly (2).
- c. Remove the two No 6 BA nuts and washers securing board G1 (Tels F 202 Pt 2 Fig 2522).
- d. Remove the two No 6 BA screws and sealing washers (3) securing the plate and stud assembly to the control panel and remove the assembly.
- e. Remove the No 6 BA screw (4) securing the riveted panel. This panel carries R1, C4 and the white lead with an orange marker.
- f. Unscrew the locking nut from the contact adjustment screw (5) and remove the solder tag and washers.
- g. Remove the key assembly securing nut (6), a special tool may be required details of which are given in Fig 4001.
- h. The key assembly can now be removed from the control panel.

To refit key assembly

29. a. Remove the new item from its transit plate, ensuring that all washers and seals are retained, with the exception of the packing washer (7) which is not required when assembling the key to the control panel.

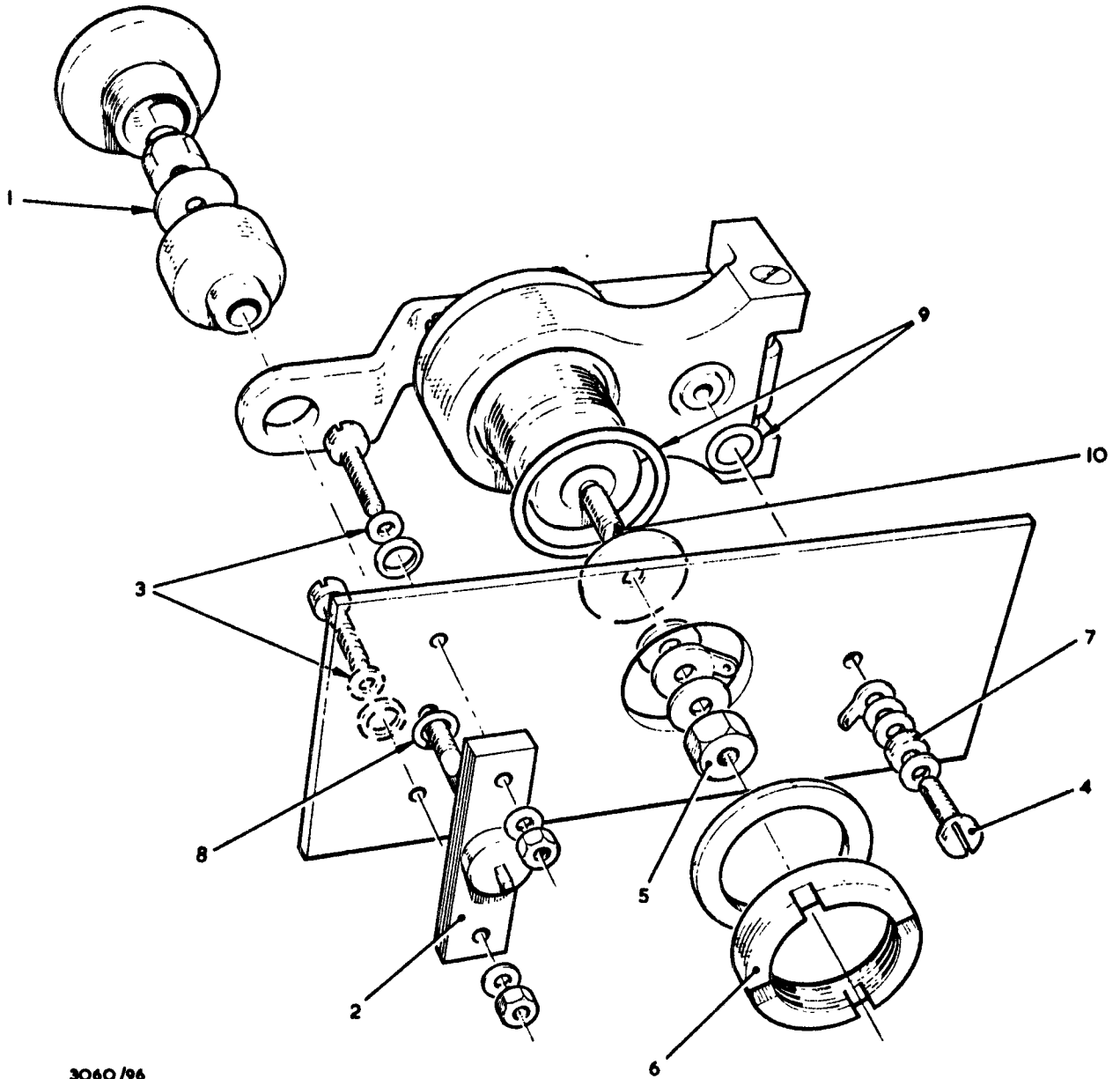

3060/96

Fig 2 - Details of c.w. key

- b. Remove the type identification plate from the old key and refit it to the replacement key.
- c. Lightly smear the sealing ring (8) with grease XG271 (H1/9150-99-910-0510) and position carefully in its recess in the plate and stud assembly. Secure the assembly in position on the control panel, ensuring that the sealing washers are fitted to the securing screws and are lightly smeared with grease.
- d. Refit board G1 and secure it with nuts and washers, the threads of the screws are to be coated with varnish Dulux anti-tracking (H1/8010-99-942-8917). Resolder wires to the plate and stud assembly.
- e. Lightly smear the sealing rings (9) with grease and position carefully in their respective recesses in the key body assembly. Fit this assembly to the control panel, securing it with the nut and washer (6) tightened to finger tightness only.
- f. Replace the screw (4) securing the riveted panel, ensuring that the washers and soldering tag are fitted in the following order; crinkle washer, panel, crinkle washer, plain washer, soldering tag. (Note that the panel replaces the packing washer discarded at a.). Do not fully tighten.
- g. Check that the stud of the plate and stud assembly is centrally positioned within the hole in the key arm. Fully tighten the key assembly securing nut (6) and screw (4), taking care that the clearance between the stud and hole is maintained.
- h. Remove the contact adjustment screw locking nut (5), refit the soldering tag removed in para 28.f. and replace the nut.

Setting the contact gap

- 30. a. Slacken off the locking nut (5) and unscrew the contact adjustment screw (10) as far as possible.
- b. Check that the key pivot screws are not over tight, if necessary slacken off the set screws and readjust. Slight side play at the operating knob of the key is acceptable.
- c. Refit the insulated washer and nut (1) on to the stud on the stud and plate assembly, so that the gap between the control panel and underside of the key arm is 0.091/0.089 in.
- d. Screw in the contact adjustment screw (10) until the lower contact touches the upper contact. Hold the screw with a screwdriver and securely tighten the lock nut (5).
- e. Unscrew the nut on the stud to increase the gap between the key arm and control panel to 0.108/0.106 in., this gives the required contact gap of 0.009/0.008 in. Replace cap (1).

Repair of key

31. When replacing any part of the key, the instructions contained in EMER Tels F 202, Part 2, Fig 2526, must be observed. Final adjustment is to be carried out as in para 30 of this regulation.

To replace control panel

32. a. Remove key.
- b. Remove all knobs and components from the control panel. It is not necessary to unsolder connections to components unless the component is to be replaced as well.
- c. Rotate the basic channel and offset control knobs so that the yellow dots on the gears are uppermost. Carefully push out the tapered pins securing the gears to the control knob shafts. Remove knobs and gears.
- d. Remove gear springs.
- e. The replacement control panel is supplied complete with all identification and instruction plates already riveted on. Transfer any strike off action from the original to the new modification record plate and the set serial number to the identification plate.
- f. Reassemble the components on the panel ensuring that the gears are correctly pinned on to the knobs. Turn the control knobs so that the unmarked position on the basic channel and the '0' on the offset are facing downwards. Fit gears to shafts so that the yellow dots are facing downwards and replace the securing pins.
- g. Replace the key and re-set the contact gap.

To replace crystal cassette (J)

33. a. Unsolder the wires to pins 3 and 4 on the crystal cassette.
- b. Unsolder the wires to board D2, pins 8 and 9.
- c. Release the four screws securing the cassette and remove.
- d. Fit new cassette using the reverse procedure, ensuring that the wire from A1-7 to pin 4 on board D3 is not trapped. Ensure that the correct type of cassette is used. Replacement cassettes are pre-aligned and should need no further adjustment.

To replace offset unit (D)

34. a. Unsolder the coaxial lead (L01 output) from terminals 1 and 4 of A2 Trough. This entails removal of the board A cover, see para 36.a.
- b. Unsolder all other connections to the unit carefully noting identification of each lead as it is removed.

- c. Remove the four securing screws. The unit may now be removed but care must be taken that the coaxial lead, unsoldered from terminals 1 and 4 of A2 trough, does not get snagged as it runs through the holes in board A and the main chassis.
- d. Fit the new unit using the reverse procedure. It is advisable to solder a length of wire to L01 output coaxial lead to facilitate threading it through the main chassis and the hole in board A.

To replace receiver a.f. board (E)

- 35.
 - a. Remove the four screws securing the offset unit and carefully lift it clear of the chassis as far as the connections to the unit will permit. This is necessary to allow board E to be lifted clear of its mounting studs, without its components fouling the offset unit. In extreme cases it may be necessary to unsolder some connections to the offset unit, or remove it completely to gain the required clearance.
 - b. Unsolder all connections to the board, carefully noting the identification of each lead as it is removed.
 - c. Release the four securing nuts, remove the board and discard.
 - d. Fit new board using the reverse procedure.
 - e. Replace the offset unit and its securing screws.

To replace r.f. board (A)

- 36.
 - a. Release the five screws securing the cover and remove cover.
 - b. Unsolder the coaxial lead from ML6 to the offset unit from pins 41 and 42 on that unit.
 - c. Unsolder the coaxial lead from L8 to board B from pins 1 and 2 on that board.
 - d. Unsolder all other connections to board A, carefully noting the identification of each lead as it is removed.
 - e. Release the two pillar screws which still secure the board to the chassis and remove the board.
 - f. Fit new board, using the reverse procedure.

To replace i.f. amplifier (C)

- 37.
 - a. Unsolder the coaxial lead from the i.f. amplifier to board B from pins 10 and 11 on that board.
 - b. Unsolder all other connections to the assembly, carefully noting the identification of each lead as it is removed.

- c. Release the three screws securing the assembly to the chassis and remove the assembly.
- d. Fit new assembly, using the reverse procedure.

To replace 2nd mixer board (B)

- 38.
- a. Unsolder all connections to the board, including the four small links to the 300Hz filter, carefully noting the identification of each lead as it is removed.
 - b. Release the two securing nuts, remove and discard the board.
 - c. Fit new board, using the reverse procedure.

To replace 300Hz filter

- 39.
- a. Remove board B.
 - b. Remove the two nuts from the mounting studs and remove the filter assembly.
 - c. Fit new filter, using the reverse procedure.

Repainting

40. Painting must be confined to touching up scratches and chipping. On no account must any cleaning or paint stripping fluid come into contact with the plastic surfaces of the case. The paints to be used are:

H1/8010-99-942-6086	Paint, priming, instruments, brushing (to CS2307)
H1/8010-99-942-6027	Paint, finishing, instruments, high gloss, brushing olive drab BS 381C Tint 298 (to CS2309)

SPECIFICATION TESTS

General

41. These tests have been divided into two classes, A and B. Those in Class A are considered essential to prove the serviceability of an equipment and are to be carried out each time an equipment is inspected or after repairs. Class B tests are those which need not be carried out on all occasions, but are included to assist in proving the correct operation of the equipment or for fault tracing. The B class of test is given thus, (B), after the title of the test.

Table 1 - Test equipment schedule

Item No	Preferred Instrument		Suitable alternative	
	Part No	Designation	Part No	Designation
1	Z4/6625-99-104-6709	Signal generator set (TF2002)	-	-
2	Z4/6625-99-106-1341	Voltmeter set, electronic (TF2600/S with probe)	Z4/6625-99-106-5334	Voltmeter set, electronic (TF2600 with probe)
3	Z4/6625-99-106-3438	Power supply set (AS1412/M)	Z4/6625-99-104-2620	Power supply set Solartron AS1412
4	Z4/6625-99-105-7106	Meter set modulation CT542	Z4/6625-99-103-5993	Test set modulation (Airmec 210)
5	Z4/6625-99-199-2562	Oscilloscope set CT531/1	Z4/6625-99-102-6694	Oscilloscope CT436
6	Z4/ZD 04247	Signal generator VF No 1 Eqpt No 2		
7	Z4/6625-99-117-5248	Counter, electrical frequency CT576A III	Z4/6625-99-933-1822	Counter frequency meter TF1417/2 *
8	Z4/6625-99-105-7049	Multimeter set CT498A	Z4/6625-99-949-1999	Multimeter, Avo, type 9SX <u>or</u>
			Z4/6625-99-943-1524	Multimeter, Avo, model 8S
9	Z4/6625-99-193-3720	Test Kit RT316	-	-
10	W3/6625-99-942-4825	Dehumidifier, desiccant, electric No 1 Mk 1 <u>or</u>	-	-
	W3/4440-99-201-3049	Dehumidifier, desiccant, electric No 2 Mk 1	-	-
11	Z4/6625-99-200-2271	Leak locator CT509	-	-
12	Z4/5820-99-103-4146	Keyer, automatic, two operating speeds	-	-
		part, of		
	Z4/5820-99-103-4697	Test kit, radio transmitter receiver A13		

42. All testing and alignment instructions are based on the use of the Test kit RT316, together with the peripheral test equipment shown in Fig 3 and listed in Table 1.

* To be used with: Z4/6625-99-104-5121 Converter, Frequency, Electronic

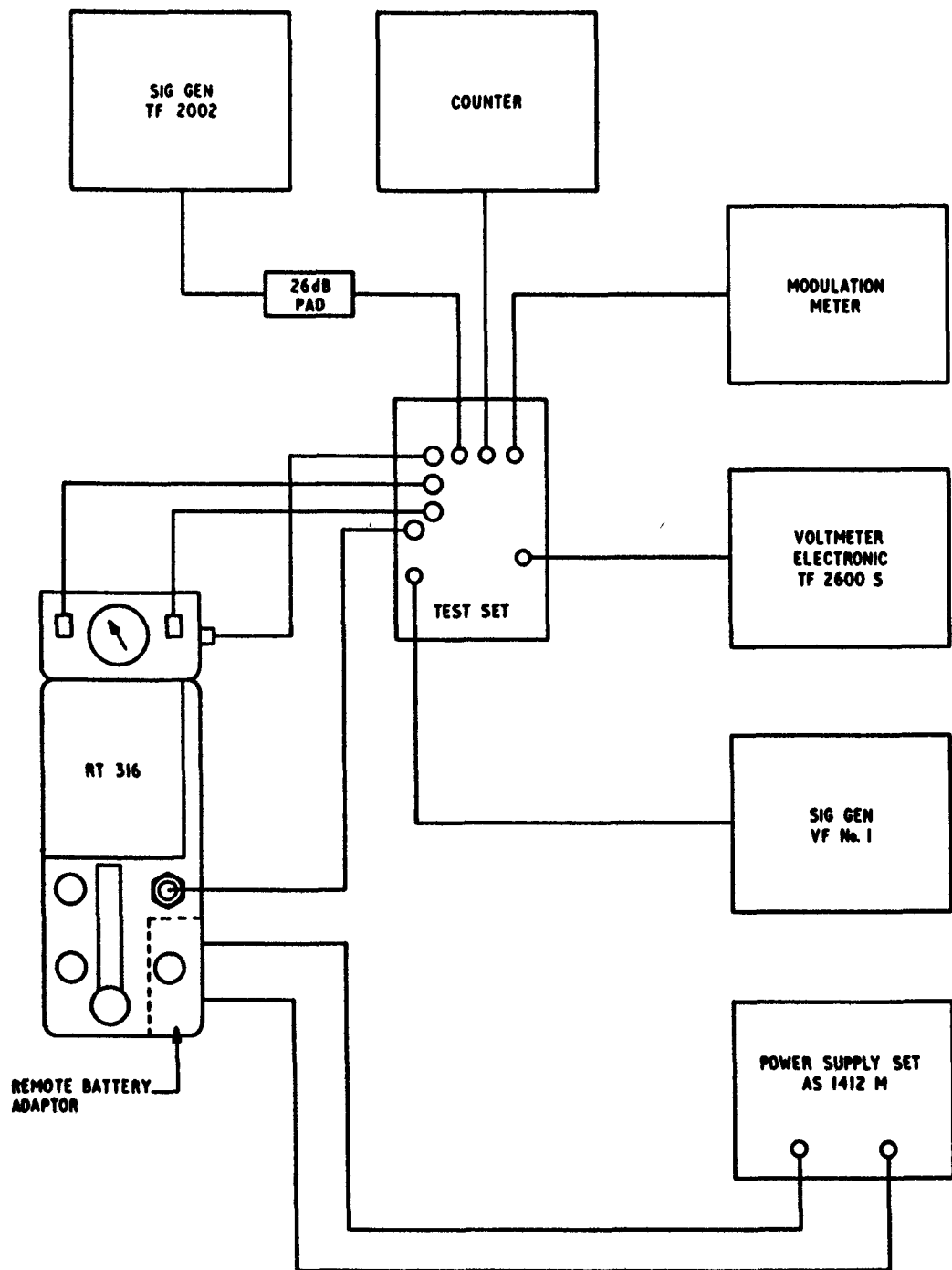

3060/95

Fig 3 - Layout of test equipment

Test conditions

Note: BEFORE CARRYING OUT ANY TESTS IT IS ESSENTIAL TO INSERT A PIECE OF SUITABLE MATERIAL UNDER THE ARM OF THE KEY TO PREVENT ACCIDENTAL KEYING OF THE TRANSMITTER.

43. A nominal supply of 12V d.c., negative to chassis, is to be applied to the set from the power supply set by means of the remote battery adaptor Z1/5820-99-106-2476 supplied with the test kit RT316. Unless otherwise stated, tests must be made at the nominal voltage, 12V, as indicated by the setting of the power supply switch and with the limiting current set to 100mA for receive condition and 1.5A for the transmit condition.

44. The set is tuned by setting the two switches to the required channel and adjusting the PEAK NOISE control for maximum noise on BATT.

45. Connect the signal generator to the interconnecting box via a 26dB pad. Note that all r.f. input voltages are quoted in terms of the open circuit voltage at the terminating unit, ie signal generator reading +10.

46. Tune the signal generator to the set by tuning for maximum noise in the headgear.

47. Connect the voltmeter electronic to the interconnecting box via the coaxial T-junction provided in the test kit, so that an oscilloscope can be connected across the output to observe the waveform. Set up the a.f. modulation by switching the test box to CHECK MOD (SB) and / mV (SC) and injecting a 5V signal from the a.f. generator at 1kHz. Adjust the SET LEVEL for an output on the VV of / mV.

48. The transmitted frequencies quoted in the specification test and alignment instructions are the limits at a temperature of $22 \pm 2^{\circ}\text{C}$. The limits at other temperatures are under investigation and will be notified as soon as possible. Meanwhile, ^{measurement or} alignment should be attempted unless the ~~ambient temperature~~ ^{remains} between 20 and 24°C for at least an hour.

Receiver Tests Class A

Sensitivity

(For these measurements disconnect counter)

C.W. narrow

49. Specification: The ratio of the a.f. output with an r.f. input of $0.45\mu\text{V}$ to the 50Ω connector or 100Ω terminals, to the a.f. output with no r.f. input must not be less than 10dB

50. Method: Set test box switch SA to Rx-50, SB to AF POWER and SC to OFF.

- a. (1) With p.s.u. set to 12.0V limit output current to 150mA, switch RT316 to KEY and tune to channel 1.A. Set GAIN control to maximum. Set the signal generator (SG) output controls to 4.5 μ V and switch to c.w. Tune the SG to the set for maximum a.f. output as indicated on the electronic voltmeter. Note this reading. Switch off SG carrier and note the new reading:

$$\frac{\text{signal} + \text{noise}}{\text{noise}} \frac{(S + N)}{N} \text{ must be greater than } 10\text{dB}$$

Repeat on channels 1.B, 1.O, 1.C, 1.D, 2.O, 3.O, 4.O, 5.O, 6.O, 7.O, 8.O, 9.O. Check that PEAK NOISE operates on all channels

- (2) The battery drain as indicated on the p.s.u. meter must not exceed 60mA on channels 4.O and 5.O.

b. With p.s.u. set to 10V, repeat 50.a.(1) on channel 4.O.

c. With p.s.u. set to 16.5V repeat 50.a.(1) and 50.a.(2) on channel 5.O. The battery drain must not exceed 85mA.

C.W. wide

51. Specification: The ratio of the a.f. output with an r.f. input of 1.8 μ V to the 50 Ω connector or 100 Ω terminals, to the a.f. output with no r.f. input must not be less than 10dB.

52. Method: a. Set test box switch SA to Rx-100. With p.s.u. set to 12.0V, tune RT316 to channel 5.O and switch to BATT.

b. Set SG output controls to 18 μ V and switch to c.w. Tune the SG to the set for maximum a.f. output. Adjust GAIN control for a reading of 125mV on the electronic voltmeter. Switch off SG carrier and note new reading on voltmeter:

$$\frac{S + N}{N} \text{ must be greater than } 10\text{dB}$$

c. Set test box switch SA to Rx-50 and repeat 52.b:

$$\frac{S + N}{N} \text{ must be greater than } 10\text{dB}$$

R/T

53. **Specification:** The ratio of the a.f. output with an r.f. input of 4.5μV modulated 30% at 1kHz to the 50Ω connector or 100Ω terminals, to the a.f. output with no modulation must not be less than 10dB

54. **Method:**

a. Set test box switch SA to Rx-100. Switch RT316 to VOICE, and channel 5.0.

b. Set SG output controls to 45μV and switch to AM. With a modulating frequency of 1kHz adjust the SG for 30% modulation. Tune the SG to the set for maximum a.f. output. Adjust GAIN control for a reading of 125mV on the electronic voltmeter. Switch off modulation and note new reading on the voltmeter.

$$\frac{S + N}{N} \text{ must be greater than } 10\text{dB}$$

c. Set test box switch SA to Rx-50 and repeat 54.b.

$$\frac{S + N}{N} \text{ must be greater than } 10\text{dB}$$

A.F. output

C.W. narrow

55. **Specification:** With a 0.45μV signal, the gain control set to maximum and a 12V supply the a.f. output shall be at least 15μW. With a 10V supply, the output shall be at least 6μW. With a 10V supply and the input signal increased to maximum a.f. output, this output shall be at least 150μW.

56. **Method:**

a. Set test box switch SA to Rx-50. With the p.s.u. set to 12.0V, tune RT316 to channel 1.A. and switch to KEY with GAIN control at maximum. Set SG output controls to 4.5μV and switch to c.w. Tune the SG to the set for maximum a.f. output. The output must be greater than 48mV.

b. Repeat 56.a. on channels 4.0, 5.0 and 9.0.

c. Set the p.s.u. to 10V on channel 4.0. The output must be greater than 30mV.

d. Increase the input signal to give maximum a.f. output; this must be greater than 150mV.

C.W. wide

57. Specification: With a $1.8\mu\text{V}$ signal, the GAIN control set to maximum and a 16.5V supply, the a.f. output shall not be less than $500\mu\text{W}$. With a 10V supply, the output shall be at least $150\mu\text{W}$. The a.f. shall lie between 700 and 1300Hz.

58. Method: a. With the p.s.u. set to 16.5V, switch the set to BATT on channel 1.0. Set SG output controls to $18\mu\text{V}$ and switch to c.w. Tune the SG to the set for maximum a.f. output. The output must be greater than 275mV.

b. Set the p.s.u. to 10V. The output must be greater than 150mV.

c. Check the a.f. on the counter. The frequency must lie between 700 and 1300Hz.

R/T

59. Specification: With a 12V supply and an input signal of $10\mu\text{V}$, modulated 30% at 1kHz, the GAIN control shall be set for an a.f. output of $500\mu\text{W}$. With a 10V supply and the same input signal as before, the GAIN control shall be set for an a.f. output of $300\mu\text{W}$. With a 16.5V supply and an input signal of $100\mu\text{V}$, modulated 85% at 1kHz, the GAIN control shall be set for an a.f. output of $800\mu\text{W}$. In each condition the distortion on the a.f. waveform shall be less than 15%.

60. Method: a. With the p.s.u. set to 12.0V, switch the set to VOICE. Set the SG output controls to $100\mu\text{V}$ and switch to a.m. With a modulating frequency of 1kHz adjust the SG for 30% modulation. Tune the SG to the set for maximum a.f. output. Adjust GAIN control for an output of 275mV. Observe the waveform on the oscilloscope, there must be no visible distortion.

b. Set the p.s.u. to 10.0V and adjust the GAIN control for an output of 210mV. There must again be no visible distortion of the waveform.

c. Set the p.s.u. to 16.5V. Increase depth of modulation to 85% and set output controls to 1mV. Adjust GAIN control for an output of 345mV. There must be no visible distortion of the waveform.

GAIN control range

61. Specification: At c.w. narrow with a 12V supply, and the gain set to maximum, an r.f. signal sufficient to give an a.f. output of 125mV shall be applied. With the gain set to minimum, the r.f. input shall be increased to produce the same a.f. output. The difference between the two r.f. signal levels shall be at least 90dB. The gain control shall be smooth over its entire range.
62. Method: a. Set the p.s.u. to 12.0V and the set to KEY with GAIN control at maximum. Set the SG to c.w. and adjust the SG output controls to give a reading of 125mV on the electronic voltmeter, note the r.f. input level. Set GAIN control to minimum and increase the SG output level to again give an output of 125mV. Note the new r.f. input level. The difference between the two r.f. input levels must be at least 90dB. Check that the gain control is smooth over its entire range with no sudden change in law.

A.F. response (R/T)

63. Specification: With an r.f. input of 5 μ V at 1kHz 30% modulation, and 12V supply, the gain control shall be set to produce 100 μ W a.f. output. Under the same conditions, but varying the modulation frequency, the relative a.f. outputs shall comply with Table 2.

Table 2 - Receiver a.f. response

Frequency	500Hz	1kHz	2kHz	3kHz
AF level dB	+1 to -6	0	+1 to -8	3 -3

64. Method: a. With the p.s.u. set to 12.0V, switch the set to VOICE. Set the SG output controls to 50 μ V and switch to AM. With a modulating frequency of 1kHz adjust the SG for 30% modulation. Tune the SG to the set for maximum a.f. output. Adjust GAIN control for an output of 125mV.
- b. Change the modulating frequency to 500Hz, to 2kHz, and to 3kHz. In each case the change in a.f. output level must not be greater than indicated in Table 2.

Selectivity

65. Specification: a. Wide band R/T using a reference signal of $5\mu\text{V}$ modulated 30% at 1kHz.

6dB bandwidth 4.5 to 7kHz
20dB bandwidth 6.5 to 10.0kHz

The mean of the 6dB points, shall be within $\pm 1.1\text{kHz}$ of the channel frequency.

- b. Narrow band c.w. using a reference signal of $0.5\mu\text{V}$.

6dB bandwidth 270-370Hz
20dB bandwidth 350-600Hz

The mean of the 6dB points shall be within $\pm 5\text{Hz}$ of the channel frequency.

66. Method:
- a. Connect the counter to the counter output socket of the SG.
 - b. Tune the set to channel 1.0, set GAIN control to maximum, and switch to VOICE.
 - c. Set the SG output controls to $50\mu\text{V}$, and with an a.m. signal, modulated 30% at 1kHz, tune the SG to the set for maximum a.f. output. Adjust GAIN control for 125mV a.f. output. Note the SG frequency, f_0 .
 - d. Set the SG output controls to $100\mu\text{V}$ and retune the SG either side of f_0 until the a.f. output is again 125mV. Note these frequencies f_1 and f_2 .
 - e. $f_2 - f_1$ must be between 4.5 and 7kHz and $\frac{f_2 + f_1}{2} - f_0$ must be between +1.1kHz and -1.1kHz
 - f. Set the SG output controls to $500\mu\text{V}$ and retune the SG either side of f_0 until the a.f. output is the same as in c. Note these frequencies f_3 and f_4 . $f_4 - f_3$ must be between 6.5 and 10kHz.
 - g. Switch the set to KEY.
 - h. Set SG output controls to $5\mu\text{V}$ and switch to c.w. Tune the SG to the set for maximum a.f. output. Adjust GAIN control for 125mV a.f. output. Note SG frequency, f_0 .

j. Set the SG output controls to $10\mu\text{V}$ and retune the SG either side of f_0 until the a.f. output is again 125mV . Note these frequencies f_1 and f_2 .

k. $f_2 - f_1$ must be between 270 and 370Hz.
 $\frac{f_2 + f_1}{2} - f_0$ must be between +5Hz and -5Hz.

l. Set the SG output controls to $50\mu\text{V}$ and retune the SG either side of f_0 until the a.f. output is the same as in h. Note these frequencies f_3 and f_4 .
 $f_4 - f_3$ must be between 350 and 600Hz.

Transmitter

R.F. power output and transmitted frequency accuracy

67. Specification:
- a. On KEY, BATT and VOICE with no modulation input the peak power output shall be greater than 3 watts into either 50Ω or 100Ω load.
 - b. The transmitted frequency shall not differ from the assigned channel frequency by more than +40Hz.
68. Method:
- a. (1) Set the test box switch SA to Tx-50, SB to RF POWER and SC to OFF.
 - (2) With p.s.u. set to 12.0V limit the output current to 2A, switch the set to KEY and tune to channel 1.A. Note and record the v.v. and counter readings.
 - (3) Repeat on channels 1.B, 1.0, 1.C, 1.D, 2.0, 3.0, 4.0, 5.0, 6.0, 7.0, 8.0, 9.0, recording the v.v. and counter readings for each channel.
 - (4) In all cases, the indication on the v.v. must exceed 12V and the frequency must be within +40Hz of the assigned channel frequency. The difference between the highest and lowest frequency errors observed must not exceed 10Hz.
 - (5) Switch SA to Tx-100, note and record the v.v. reading and p.s.u. current on channels 1.A, 4.0, 5.0 and 9.0.
 - (6) In all cases, the v.v. indication must exceed 8.5V and the input current must not exceed 1.5A.

(7) Reduce the p.s.u. voltage to 10V and switch the set to the channel observed as giving the lowest v.v. reading at (3). Note and record the v.v., front panel meter, and counter readings. The readings on the v.v. and front panel meter must exceed 8.5V and 1/2 f.s.d. respectively. The frequency must be within +48Hz of the assigned channel frequency.

(8) With SA to Tx-50 increase the p.s.u. voltage to 16.5V and switch the set to the channel observed as giving the highest v.v. reading at (3). Note and record the v.v., front panel meter, and counter readings. The readings on the v.v. and front panel meter must exceed 12V and be less than f.s.d. respectively. The frequency must be within +48Hz of the assigned channel frequency.

b. Re-set the p.s.u. to 12V and switch the set to BATT. The v.v. indication must exceed 12V and the input current must not exceed 1.5A. The frequency must be within +40Hz of the assigned channel frequency.

c. With SA to Tx-100 switch the set to VOICE. Switch to the channel observed as giving the lowest v.v. reading at (3) and record the v.v. reading. Switch test set SC to 5mV and note that the output falls; record the v.v. reading. The difference between the two readings must be between 4 and 5.5dB.

Modulation sensitivity and distortion

69. Specification: With a 12V supply and 1kHz input, the modulation depth shall comply with Table 3.

Table 3 - Modulation sensitivity

A.F. input (mV)	1		2		5		20	
	Peak	Trough	Peak	Trough	Peak	Trough	Peak	Trough
% modulation on channel with highest power output	15-60	15-60	>30	>30	>60	>60	>80	>80
% modulation on channel with lowest power output	15-60	15-60	>30	>30	>60	>60	>80	>80

With an input of 1mV at 1kHz total distortion shall not exceed 15%. At any of the a.f. inputs in Table 3 there shall be no envelope discontinuities or lack of symmetry when the transmitted wave is viewed on the oscilloscope.

70. Method:
- a. Set SA to Tx-50, SC to 1mV and the set to VOICE. Using the channel observed as giving the highest v.v. reading at para 68.(3) (excluding channels below 2.5MHz), measure the percentage modulation with the modulation meter set to PEAK then to TROUGH.
 - b. Repeat para 70.a. with SC to 2mV, 5mV and 20mV. The percentage modulation must be as given in Table 3.
 - c. Repeat para 70.a. and b. using the channel observed as giving the lowest v.v. reading at para 68.(3).
 - d. With any input there must be no discontinuities or lack of symmetry when the waveform is viewed on the oscilloscope.

A.F. response

71. Specification: With a 12V supply and an a.f. input of 2mV, vary the modulating frequency. The modulation response shall comply with Table 4.

Table 4 - Transmitter a.f. response

Frequency (Hz)	500	1000	2000	3000	5000
Response (dB)	-6 to -18	0	0 to -6	-2 to -10	<-4

72. Method:
- a. Disconnect the v.v. from the test box SKE and connect it to the a.f. output of the modulation meter. Using the channel observed as giving the highest v.v. reading at para 68.(3) and a modulation frequency of 1kHz at 2mV, adjust the modulation meter input attenuator to give a reading of 300mV (0dB) on the v.v.
 - b. Retune the a.f. generator to 500Hz, 2kHz, 3kHz and 5kHz in turn.
 - c. In each case the reading on the v.v., in respect to that at 1kHz, must be within the limits given in Table 4.
 - d. Restore the v.v. connection to SKE.

Sidetone

73. Specification: With a 12V supply, the a.f. sidetone output shall comply with Table 5.

Table 5 - Sidetone

	CW NB	CW WB	R/T mod input 5mV
Frequency (Hz)	700 to 2000	700 to 2000	1000
AF output (mV)	50 to 135	50 to 135	35 to 135

74. Method:
- a. Disconnect the counter from SKC and connect it across the v.v.
 - b. With the set to KEY (c.w. narrow band), SB to AF POWER and SC to OFF, measure and record the a.f. output and frequency.
 - c. Repeat with the set to BATT (c.w. wide band).
 - d. With the set to VOICE (R/T) and SC to 5mV, measure and record the a.f. output and frequency.
 - e. In each case, the a.f. output and frequency must be within the limits given in Table 5. Restore the counter connection to SKC.

CW operation (B)

75. Specification: With the transmitter keyed at 25 w.p.m. (50 ms dots alternating with 50 ms spaces) or 6 w.p.m. (200 ms dots alternating with 200 ms spaces), the keyed waveform shall be sensibly square when viewed on an oscilloscope.
76. Method:
- a. Disconnect the modulation meter from SKD and connect the oscilloscope in its place.
 - b. With 12V input and the automatic keyer set to 25 w.p.m. plugged into the test box, switch the set to KEY and observe the transmitted waveform displayed on the oscilloscope. The waveform must be substantially square, with no peak having an amplitude greater than 20% above the final steady amplitude for longer than 10 ms.
 - c. Repeat with the automatic keyer set to 6 w.p.m.
 - d. Disconnect oscilloscope from test box.

High speed keying operation

77. Specification: The application of 4V negative to the battery guide pin shall inhibit the action of the transmitter.

78. Method:
- a. Switch off the power unit and remove the remote battery adaptor. Fit the special adaptor over the guide and battery pins and connect to a 4V source, ensure the 4V source is switched off. Refit the remote battery adaptor and switch on the power unit.
 - b. Switch the set to KEY on any channel and the test box SA to Tx-50.
 - c. Switch on the 4V source. The transmitter output must drop to zero. Switch off the 4V source and the output must be restored.
 - d. Remove special adaptor.

Mismatch

79. Specification: The transmitter shall be operated at c.w. (narrow band) with the supply at 16.5V and the 100Ω antenna connection short circuited. No damage shall result. During the test, the r.f. current flowing between the antenna terminals shall not exceed 300mA.
80. Method:
- a. Set the p.s.u. to 16.5V and the current limit to 1.5A.
 - b. Switch the set to KEY on the channel observed as giving the highest v.v. reading at para 68.(3). Tune the set and then remove the 100Ω antenna connector from the set.
 - c. Short circuit the 100Ω terminals on the set. Switch to Tx-100. The input current must not exceed 1.5A. ie the p.s.u. must not limit. Switch to Rx-100.
 - d. Remove the short circuit and replace the 100Ω antenna connector.

Antenna current meter

81. Specification: The meter shall indicate between 50% to 100% of f.s.d. when the peak noise control is adjusted on channels 1.0 and 9.0 and the equipment is at transmit (KEY and VOICE with no modulation) into both 50Ω or 100Ω loads. On VOICE with 5mV 1kHz modulation input the meter reading shall be less than with no modulation input. The arc described by the tip of the meter pointer, when the modulation is alternately switched on and off shall be not less than 0.15 in. (4 mm).

82. Method:
- a. Set the p.s.u. to 16.5V.
 - b. Switch the set to KEY on the channel observed as giving the highest v.v. reading at para 68.(3).
 - c. Switch test set to Tx-50. Note and record the reading on the set meter.
 - d. Set the p.s.u. to 10V and switch the set to the channel observed as giving the lowest v.v. reading at para 68.(3). Switch to Tx-100. Note and record the reading on the set meter.
 - e. Repeat para 82.a. to d. with the set switched to VOICE with no modulation.
 - f. The meter reading must be between 50% and 100% f.s.d.
 - g. Set the p.s.u. to 12V. Switch the set to the channel observed as giving the highest v.v. reading at para 68.(3). Switch SC to 5mV and set the modulating frequency to 1kHz. Note the reading on the meter. Switch SC to OFF, the reading on the meter must be less than that obtained with modulation. The arc described by the tip of the meter pointer when the modulation is switched on and off must be not less than 0.15 in. (4 mm).

Battery meter

83. Specification: Meter readings at BATT shall be in accordance with Table 6.

Table 6 - Battery meter readings

Supply volts	8.6 to 9.4V	9.7 to 10.3V	16.5V
Meter reading	just moving off 0	10 volt mark	60 to 100% f.s.d.

84. Method:
- a. Switch to Rx-50 with set to BATT on any channel.
 - b. Adjust the input voltage so that the meter just rises from the back-stop. The input voltage must lie between 8.6 and 9.4V.
 - c. Adjust the input voltage so that the meter needle coincides with the 10V mark on the scale. The input voltage must lie between 9.7 and 10.3V.
 - d. Adjust the input voltage to 16.5V when the meter needle deflection must be between 60% and 100% f.s.d.

ADJUSTMENTS AND ALIGNMENT

Preliminary

85. Unplug the control panel and chassis assembly from the main case and place it in the Spreader Frame, Item 9 of the Test Kit, ensuring that the basic and offset gears are engaged in the correct teeth.
86. Reconnect the control panel to the main case via the 16 way connector, Item 4 of the Test Kit. Connect the main case to the p.s.u. via the battery adaptor, Item 3.

Tuning voltage coverage

87. Connect the Multimeter, switched to its 10V d.c. range, between board D3 pin 4 (+ ve) and chassis. With the PEAK NOISE control fully anticlockwise, put the set to KEY. The multimeter reading must be less than 4V.
88. Switch the multimeter to its 250V d.c. range and turn the PEAK NOISE control fully clockwise. The multimeter reading must exceed 100V.

Offset oscillator

89. Connect the counter to board B1 pin 3. Adjust the trimmers A, B, O, C and D on the offset unit D, so that the frequency measured at each switch position is as given in Tables 2512 or 2513.

Crystal cassette

90. Connect the counter to the offset unit D2 pin L01. On initial setting up only, set crystal cassette trimmers C1 to C10 inclusive to mid-position.

91. Switch the basic channel switch to channel 1 and adjust C1 for basic crystal frequency $\pm 1\text{Hz}$ (see Table 2512 or 2513). Repeat on channels 2 to 9 adjusting the appropriate trimmer.

92. It may not be possible to set some channels to their correct frequency. In this case, set them as near as possible using the individual trimmers, then adjust C10 until it is possible to set each channel correctly.

1st i.f. (L7, L8) alignment

93. Switch the set to BATT and the gain control to maximum (fully clockwise). Put the basic channel switch to the tenth position (unmarked).

94. Connect the signal generator set to $8\text{MHz} \pm 100\text{Hz}$, 1mV c.w. to the off-set unit D2 pin L01.

95. Adjust L7 and L8 for maximum reading on the a.f. power meter, reducing the SG input to keep the output below 120mV .

R.F. amplifier low band alignment

96. a. Set the basic channel switch to the position giving the lowest channel frequency in the band 2 to 3.75MHz . Put the offset switch to position 0.

b. Put the set to BATT and the GAIN control to maximum.

c. With the test set to Rx-50, set the SG to the true frequency of the selected channel with 100mV c.w.

d. Connect the multimeter, switched to its 10V d.c. range, between the offset unit D3 pin 4 (+ ve) and chassis.

e. Adjust the PEAK NOISE control for a reading on the multimeter corresponding to the true channel frequency as given in Table 7.

f. Adjust L1, L2 and L3 on r.f. amplifier board A, for maximum a.f. output, reducing the SG input to keep the output below 120mV .

97. Set the basic channel switch to the position giving the highest channel frequency in the band 2 to 3.75MHz . Set the SG to the true frequency of the selected channel. Adjust the PEAK NOISE control for a reading on the multimeter corresponding to the true channel frequency as given in Table 7. Adjust C3, C5 and C8 on r.f. amplifier board A, for maximum a.f. output, reducing the SG input to keep the output below 120mV .

Table 7 - R.F. amplifier typical tuning volts/frequency table

Volts	Frequency (MHz)		Volts	Frequency (MHz)	
	Low Band	High Band		Low Band	High Band
4.149	2.000	3.750	20.64	2.750	5.156
4.375	2.020	3.788	21.68	2.777	5.208
4.611	2.040	3.825	22.77	2.805	5.260
4.858	2.061	3.864	23.92	2.833	5.312
5.116	2.081	3.902	25.13	2.862	5.365
5.388	2.102	3.941	26.41	2.890	5.419
5.672	2.123	3.981	27.75	2.919	5.473
5.969	2.144	4.021	29.16	2.948	5.528
6.281	2.166	4.061	30.64	2.978	5.583
6.608	2.187	4.101	32.21	3.008	5.639
6.950	2.209	4.142	33.85	3.038	5.695
7.309	2.231	4.184	35.59	3.068	5.752
7.686	2.254	4.226	37.41	3.099	5.810
8.080	2.276	4.268	39.34	3.130	5.868
8.494	2.299	4.311	41.37	3.161	5.927
8.928	2.322	4.354	43.50	3.193	5.986
9.382	2.345	4.397	45.76	3.224	6.046
9.860	2.369	4.441	48.13	3.257	6.106
10.36	2.392	4.486	50.64	3.289	6.167
10.89	2.416	4.530	53.29	3.322	6.229
11.44	2.440	4.576	56.08	3.355	6.291
12.01	2.465	4.621	59.03	3.389	6.354
12.62	2.489	4.668	62.15	3.423	6.418
13.26	2.514	4.714	65.44	3.457	6.482
13.93	2.539	4.762	68.92	3.492	6.547
14.63	2.565	4.809	72.60	3.527	6.612
15.36	2.591	4.857	76.48	3.562	6.678
16.14	2.616	4.906	80.60	3.597	6.745
16.95	2.643	4.955	84.95	3.633	6.813
17.80	2.669	5.004	89.56	3.670	6.881
18.70	2.696	5.054	94.43	3.706	6.950
19.64	2.723	5.105	99.60	3.743	7.019

98. Repeat 96. and 97. until no further improvement is possible. The final adjustments shall be made with the set to KEY.

R.F. amplifier high band alignment

99. Set the basic channel switch to the position giving the lowest channel frequency in the band 3.75 to 7MHz. Put the set to BATT.

100. Set the SG to the true frequency of the selected channel. Adjust the PEAK NOISE control for a reading on the multimeter corresponding to the true channel frequency as given in Table 7. Adjust L4, L5 and L6 on r.f. amplifier board A, for maximum a.f. output, reducing the SG input to keep the output below 120mV.

101. Set the basic channel switch to the position giving the highest channel frequency in the band 3.75 to 7MHz. Set the SG to the true frequency of the selected channel. Adjust the PEAK NOISE control for a reading on the multimeter corresponding to the true channel frequency as given in Table 7. Adjust C2, C6 and C9 on r.f. amplifier board A, for maximum a.f. output, reducing the SG input to keep the output below 120mV.

102. Repeat para 100. and 101. until no further improvement is possible. The final adjustments shall be made with the set to KEY.

Off-set unit Tx drive mixer T3, alignment

103. Connect the electronic voltmeter between offset unit D2 pin L01 and chassis. Put the set to KEY and basic and offset channel switches to channel 1.0. Adjust the PEAK NOISE control for maximum a.f. output. Put the test set to Tx-50. Tune the offset unit T3 for a maximum reading on the electronic voltmeter. Remove the voltmeter and reset test set to Rx-50.

455kHz oscillator

104. Connect the frequency counter to offset unit D2 pin 6. Put the test set to Tx-50 and check that the frequency measured is 455kHz +20 to +32Hz. Put the test set to Rx-50.

Transmitter frequency setting and checks

105. Connect the counter to the TRANSMIT FREQ socket on the test set. Put set to KEY and basic and offset channel switches to channel 1.0. Adjust PEAK NOISE control for maximum output on voltmeter. Put test set to Tx-50 and readjust PEAK NOISE control for maximum r.f. power output. Adjust crystal cassette trimmer C1 so that the transmitter frequency is the same amount above the true channel frequency as the 455kHz oscillator frequency (para 104) is above 455kHz. Check that the reading on the set meter is not less than 50% of f.s.d. Check that the power indication is not less than 12.75V. Repeat the above on channels 2.0, 3.0, 4.0, 5.0, 6.0, 7.0, 8.0 and 9.0.

ADAPTOR UNIT KEYER INTERFACE - 316

MECHANICAL REPAIRS AND ADJUSTMENTS

Removal of panel electronic circuit

106. a. Unscrew the ten countersunk screws securing the cover plate on the adaptor unit and remove the plate.
- b. Remove the five cheese headed screws securing the panel electronic circuit, the panel can now be lifted clear of the adaptor unit.
- c. Unsolder the cableform from the panel, carefully noting the identification of each wire as it is removed.

Removal of plugs and sockets

107. a. Carry out actions detailed in para 106.a. and b.
- b. Full access for removal of plugs and sockets is now given. The length of the cableform is sufficient to allow the relevant plug or socket to be removed from the adaptor unit before unsoldering the leads to it.

SPECIFICATION TESTS

Test conditions

108. The adaptor unit is to be tested with the Cable assembly, switch electrical (Z1/5820-99-110-6652) connected to SK4 (Thorn-Bendix 6 pin - coded KEYER).
109. The standard loads detailed in Table 8 are to be connected except when specifically removed for particular tests.

Table 8 - Standard loads for adaptor unit keyer interface

Standard load	Details
1	10Ω ±5% 5W (Z30/5905-99-222-7000) connected between Pin B of SK3 and Pin C of SK3 (Pin C is the guide pin hole adjacent to the negative supply connection Pin B)
2	500Ω ±10% 1/2W connected between Pin C of PL2 and Pin H of PL2 (PL2 connects to Keyer, when in use)

110. The power supply unit is connected to the adaptor unit via the remote battery adaptor, part of Test kit RT316.

Functional tests

Current consumption

111. Specification: With the supply voltage and conditions as in Table 9 the currents drawn from the power supply shall not exceed those stated.

Table 9 - Current consumption

Input volts	Test conditions	Current
10	Standard loads 1 and 2 connected	600mA
16.5	Standard loads 1 and 2 connected	550mA
16.5	Standard loads 1 and 2 connected and pin D and pin F of PL2 short circuited together	225mA

112. Method:
- Set the p.s.u. to 10V.
 - Connect a Multimeter, set to its 1A d.c. range, in series with the negative supply to the adaptor.
 - Operate the pressel switch on the cable assembly, switch electrical. The reading on the multimeter must not be greater than 600mA.
 - Set the p.s.u. to 16.5V, operate the pressel switch. The reading on the multimeter must not be greater than 550mA.
 - Connect pin D and pin F of PL2 together, operate the pressel switch. The reading on the multimeter must not be greater than 225mA.
 - Remove the multimeter and the connection between pins D and F of PL2.

Output voltages

113. Specification: With the supply voltage first at 10V and then at 16.5V and standard loads 1 and 2 connected the output voltages shall be as follows:-

Transmit inhibit voltage to RT316: -4.2 to -5.6V
Supply voltage to Keyer: +11.0 to +13.0V

114. Method:
- a. Set p.s.u. to 10V.
 - b. Connect a multimeter, set to its 10V d.c. range, across the 10 Ω resistor, negative to pin C of SK3.
 - c. Connect a multimeter, set to its 30V d.c. range, across the 500 Ω resistor, negative to pin C of PL2.
 - d. Operate the pressel switch. The reading on the multimeter across the 10 Ω resistor must be between 4.2 and 5.6V. The reading on the multimeter across the 500 Ω resistor must be between 11.0 and 13.0V.
 - e. Set p.s.u. to 16.5V and repeat d.
 - f. Connect pin D and pin F of PL2 together, operate the pressel switch. The reading on the multimeter across the 10 Ω resistor must not be greater than 0.2V.
 - g. Remove the connection between pins D and F of PL2.

Keying test

115. Specification: When keyed with alternate marks and spaces of 3ms duration, the waveform on an oscilloscope connected across standard load 1 shall be a square wave with no spikes greater than 1V above the final steady amplitude of any mark or space.
116. Method:
- a. Remove standard load 2 and connect Keyer unit KY463/GRA71 (5820-00-056-6853) to the cable assembly, switch electrical.
 - b. Connect an oscilloscope across the 10 Ω resistor.
 - c. With the pressel switch closed, operate the IDY switch on the Keyer.
 - d. The waveform on the oscilloscope must be a square wave with no noticeable slope on the leading or trailing edges of the waveform.
 - e. There must be no spikes with an amplitude greater than 1V above the final steady amplitude of any mark or space.

SK1 and SK2 check

117. Specification: When the adaptor unit is connected to the RT316 it shall be possible to operate the set by using a head-set assembly connected to the adaptor.

118. Method 1 (using RT316):
- a. Remove standard load 1 and plug the adaptor unit into the RT316.
 - b. Connect SK2 on the adaptor (coded PEC316) to the headset socket on the RT316.
 - c. Connect a headset assembly (part of Test kit RT316) to SK1 on the adaptor.
 - d. Switch RT316 to VOICE and adjust GAIN and PEAK NOISE for maximum noise in the headset.
 - e. Operate pressel switch on headset assembly and speak into the microphone. The RT316 meter should deflect, indicating modulation.

Method 2 (using multimeter):

Check for continuity between SK1 and SK2 as follows:-

<u>SK1</u>		<u>SK2</u>
Pin A	to	Pin A
Pin B	to	Pin B
Pin C	to	Pin C
Pin D	to	Pin D

REMOTE BATTERY ADAPTOR

General

119. The adaptor cannot be repaired, but the following tests must be carried out before discarding the unit.

Functional tests

Input current with no load

120. Specification: With an input voltage of 12 $\pm 0.3V$ the input current under no load condition shall not be greater than 5mA.
121. Method:
- a. Connect the power supply unit set to 12V, in series with the multimeter set to 10mA d.c., to the input socket of the adaptor. Ensure correct polarity of connections.
 - b. Switch on the power supply. The current, as read on the multimeter, shall not be greater than 5mA.

Output voltage on load

122. Specification: With an input at any voltage between 8 and 17V and an output load of 10 Ω , the voltage drop between input and output shall not be greater than 0.5V.
123. Method:
- a. Remove the multimeter from the input to the adaptor.
 - b. Connect a 10 Ω \pm 5% 40W resistor across the output socket.
 - c. Set the power supply to give an 8V input and measure the voltage across the 10 Ω load. The output voltage shall not be less than 7.5V.
 - d. Increase the input to 17V, the output voltage shall not be less than 16.5V.

Over voltage protection

124. Specification: With an input at any voltage between 19 and 32V there shall be no output from the adaptor.
125. Method:
- a. With test conditions as in para 123, set power supply to give a 19V input. There shall be no output voltage as measured across the load.
 - b. Repeat with power supply set to 32V there shall be no output voltage from the adaptor.

Reversed polarity protection

126. Specification: With an input voltage in the range 0-32V, connected in reverse polarity, there shall be no output from the adaptor and the input current shall not exceed 5 μ A.
127. Method:
- a. Reverse the connections to the power supply and connect the multimeter, set to its 50 μ A d.c. range, in series with the input lead.
 - b. Vary the input voltage from 0-32V, there shall be no output from the adaptor and the input current as read on the multimeter, shall not exceed 5 μ A.

The next page is Page 1001

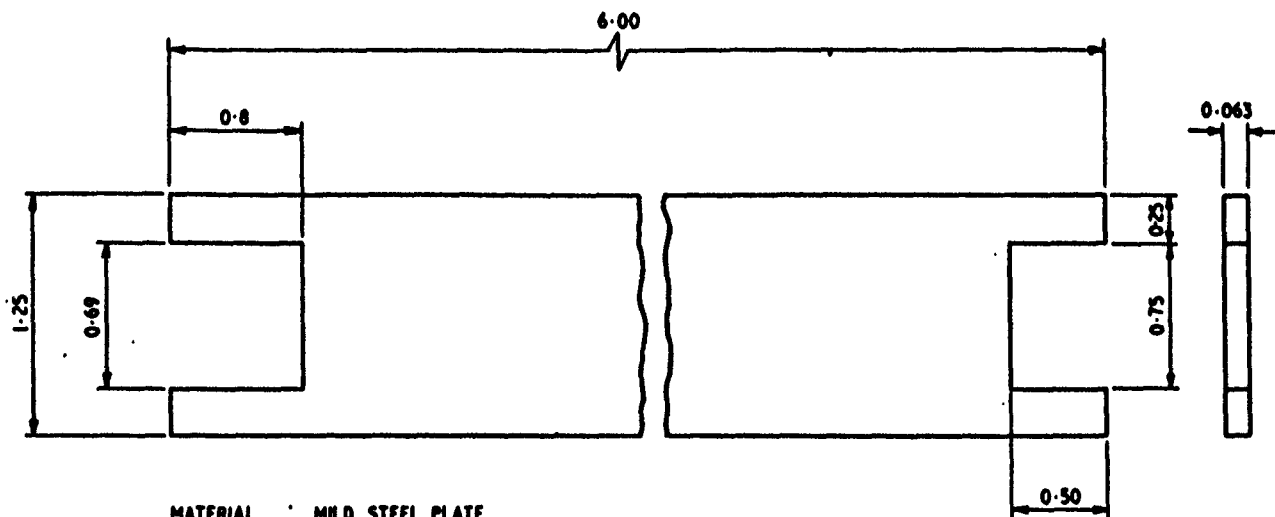

MATERIAL : MILD STEEL PLATE
THICKNESS : SUGGEST 16 SWG $\begin{matrix} 0.69 \\ 0.62 \end{matrix}$
FINISH : EMER WKSPS G500
DIMENSIONS : INCHES
TOLERANCE : ± 0.005

3060/84

Fig 4001 - Details of combined meter and key spanner

EME/8/3060/TelB

END

