

“DOLPHIN” RADIO TELEPHONE

TECHNICAL INSTRUCTIONS



Contents

	Page
General Description	3
Installation	5
Controls	7
Metering	8
Preliminary Adjustments to Transmitter/Receiver	9
Determination of Approximate Tapping Position on P.A. Aerial Coil ..	10
Operating Instructions	12
Voltage Analysis	13
Servicing	15
Electrical Interference	21
Diagrams	23

Dolphin — General Description

General

The marine set consists of a transmitter and receiver housed in a single metal cabinet approximately 21 inches tall by 15 inches wide by 9 inches deep. All controls are brought to the front panel and are fitted with rubber seals to prevent the entry of water under normal conditions of operation. Similar precautions have been taken at the junction of the front panel and the cabinet, and thus the complete set may be described as “splashproof.”

The power for the transmitter/receiver is derived initially from a 12-volt storage battery, although a modified version can be made available for 6-volt operation.

While the marine transmitter/receiver normally operates on a supply having a negative earth, it is possible, by reversing two pairs of leads in the transmitter power unit to permit operation with a positive earth supply.

The receiver has been designed to be extremely economical in operation, it taking less than 0.5 ampere from a 12-volt battery.

Receiver

The receiver is a five valve, two waveband superheterodyne, employing miniature type 1.5 volt valves.

A tuned aerial circuit with an accessible aerial compensating trimmer precedes a radio frequency amplifying stage. The radio frequency amplifier and the frequency changer stage are coupled together by a tuned anode arrangement, while the oscillator section of the frequency changer valve is of the conventional tuned grid/anode feedback type. Particular care has been taken to reduce oscillator radiation to an extremely low level.

Two high Q intermediate frequency transformers couple the I.F. valve, firstly back to the frequency changer stage, and secondly, to the following detector and audio amplifying stage. The diode section provides signal rectification and automatic volume control voltage to the R.F. and I.F. valves. A resistance/capacity arrangement couples the A.F. amplifier to the output valve, which in turn feeds a 5-inch moving coil loudspeaker.

High tension is derived from a non-synchronous vibrator and transformer feeding a full-wave metal rectifier. R.F. and A.F. filtering is incorporated to ensure “hash” and hum-free operation of the receiver.

Transmitter

This unit consists of an eight-channel Pierce type crystal oscillator, the crystals being selected by a multi-way switch. The output from the oscillator is fed to the grid of the power amplifier valve operating in Class C. Grid leak bias is used with a small amount of cathode bias to prevent damage in the event of crystal oscillator failure.

The aerial circuit consists of a reactance transformer (tapped series inductance with variable condenser from anode to ground). A suitable tap is selected by a multi-way switch ganged to the crystal selector switch, and each tap is individually adjusted on installation to

suit both aerial and crystal frequency. Final tuning is achieved by adjustment of the variable condenser. An aerial relay switches the aerial from the receiver to the transmitter.

Screen and anode modulation, employing a modulator chain comprising pre-amplifier and modulator, is used.

Aerial current metering is achieved by rectifying part of the aerial voltage and feeding the D.C. to the panel meter via the meter selector switch.

Facilities are provided for tuning the receiver to the transmitter frequency (Netting).

A rotary transformer is used to supply 450 volts H.T. to the transmitter, and is switched on by depressing the transmit/receive switch on the microphone handset. This operation energises three relays, allowing one to supply 12 volts to the rotary transformer, the second to switch off the receiver and the third to change the aerial over.

A heavy duty type plug and socket supplies L.T. to the complete set, and a fuse is incorporated in the H.T. output lead from the rotary transformer.

Installation

Transmitter/Receiver

The unit should be fitted to a convenient bulkhead at a point as close to the aerial lead-in as is possible. It is also necessary, however, to ensure that the voltage at the input plug, with a charged battery, does not fall below 11.5 volts due to voltage drop in the battery lead. If the battery lead must be long it will be necessary to increase the effective diameter of the conductors to overcome the loss in voltage. The battery lead itself should be lead-covered or run in an earthed conduit to prevent picking up interference. Electrical systems vary as to whether the positive or negative line is earthed, and it has therefore been made possible to use either system by reversing two sets of two leads fitted internally.

The equipment is normally sent out with a negative earth system. In order to make it suitable for a positive earth system the following procedure should be adopted.

Remove the transmitter/receiver from the case and lay it face downwards.

Receiver Power Unit

Unscrew two screws shown at "X" in Fig. 1.

Reverse the leads and replace the screws.

Note.—Negative Earth—Black flex lead to Black wire, Blue flex lead to Blue wire.

Positive Earth—Black flex lead to Blue wire, Blue flex lead to Black wire.

Transmitter Power Unit

Detach the braid leads on the rotary transformer "Y" by removing two screws. Reverse the leads and replace the screws.

Note.—Negative Earth—Black flex lead to Black terminal, Blue flex lead to Blue terminal.

Positive Earth—Black flex lead to Blue terminal, Blue flex lead to Black terminal.

Important.—With positive earth systems it should be borne in mind that both the receiver chassis and vibrator power unit chassis are at a potential 12 volts negative with respect to the main unit, and therefore care should be taken that metallic objects are not brought in contact indiscriminately with the chassis assemblies.

Earthing of Equipment

In order to obtain best results the set should be efficiently grounded, and it is suggested that a short direct copper braid connection be made between one of the case-fitting bolts and the nearest effective "ground" point. The "ground" point may be any convenient metallic object that is in direct contact (via a moderately large surface area) with the water. Various likely points are as follows:—

- (a) Non-metallic hulls—
 - (i) Metal keel.
 - (ii) Engine bearer bolts.
 - (iii) Rudder mounting.
 - (iv) Copper plate fitted to hull.

- (b) Metal hulls—
 - (i) As above.
 - (ii) Metal hull.

It is advisable in the case of boats using petrol engines to avoid fitting the transmitter/receiver in a position likely to be in the field of ignition interference. If excessive electrical interference is experienced in spite of these precautions, it should be dealt with at its source by a qualified electrical engineer.

Aerials

It is difficult to recommend the best aerial to instal unless the type of boat to be fitted is specified, but for best results a long wire aerial, either “T” or inverted “L” type, should be installed if at all practicable. The following points should be borne in mind when erecting these aerials.

- (a) The aerial should be erected as high as possible and kept clear of surrounding objects.
 - (b) The lead-in should be as direct as possible, at the same time bearing in mind the possibility of picking up interference.
 - (c) Adequate insulation must be used. At least one insulator at each support must be used, together with a “lead-in” insulator to the place of operation.
 - (d) The aerial should be as long as possible, although it is better if it does not exceed a quarter wavelength at the highest frequency in use.
 - (e) If a horizontal inverted “L” type of aerial is used, the top section (or roof) should slope down slightly towards the lead-in, rather than the reverse.
 - (f) Avoid fitting insulators too close to the mast, etc. Always leave a clearance of at least 12 inches.
 - (g) Avoid having finger-tight junctions in the aerial. It is always best to have a continuous run of wire from the start to finish of the aerial. Any joins should be soldered or, failing that, bolted securely and coated with a varnish or other insulating material.
- Diagrams showing general types of aerials in use are given in Fig. 2.

Controls etc. on the Front Panel

(Fig. 3)

(A) **Transmitter Indicator Lamp.**—This is fed from the same L.T. source as the rotary transformer and is illuminated by the operation of the send/receive switch on the handset.

(B) **Meter,** which is used in conjunction with the metering switch (C) to check parts of the transmitter/receiver and to provide a visual means of adjusting certain circuits.

(C) **Metering Switch.**—See (B).

(D) **Aerial Tuning Control.**—This is a panel control allowing final adjustment of the transmitter aerial circuit. The approximate readings can be marked on the escutcheon.

(E) **Netting Switch.**—This control applies a voltage to the master oscillator valve. The slight radiation in the equipment at crystal frequency permits the receiver to be tuned to the transmitter frequency.

(F) **Channel Selector.**—A two-gang eight-way ceramic insulated switch selects any one of up to eight crystals and at the same time connects the anode of the power amplifier to the correct tap on the aerial coil. The tap on this coil must be set up in position and is dependent upon frequency and aerial parameters.

(G) **Transmitter ON/OFF Switch.**—To reduce battery drain during long periods of listening the heaters of the transmitter may be switched off by this control.

(H) **Loudspeaker.**—A 5-inch permanent magnet loudspeaker is mounted behind a metal grille, together with a waterproof skin.

(I) **Tuning Dial.**—This is a circular, edge-lit Perspex dial divided equally into two and having one waveband in each half. A frequency calibration is given for each band.

(J) **Volume Control.**—This is an audio frequency gain control operating in the grid circuit of the first A.F. valve.

(K) **Tuning Control.**—To provide smoothness of operation a nylon and glass cord drive is fitted with a reduction ratio of approximately 18 : 1.

(L) **Receiver Band Switch.**—A two-position switch for selecting either the 1520–3800 kc/s. band or the 1600–530 kc/s. band (197–79 metres and 188–568 metres).

(M) **Main ON/OFF Switch.**—Operation of this switch completely shuts down the equipment.

(N) **Handset Plug.**—Three circuits are available at this point:—

(a) Microphone input.

(b) Relay switching points.

(c) Loudspeaker terminals.

These enable the use of either a normal microphone type or a combined telephone type of handset.

(P) **Power Input Plug.**—This is a two-point plug with one side earthed. Either positive or negative earth can be used, it being necessary to change over two sets of screw terminals inside the equipment. (See INSTALLATION.)

(Q) **Fuse.**—Fitted in the H.T. output lead from rotary transformer and rated at 250 mA.

Metering

(1) **L.T.**—This indicates the battery voltage as applied to the receiver. The reading is arbitrary, but has a calibration point fixed for 12 volts input at the plug (P). This calibration point is marked on the escutcheon.

(2) **A.V.C.**—The screen voltage of the R.F. and I.F. valves is applied to the meter. Thus, any signal operating the automatic volume control will cause a rise in screen volts and hence a rise in meter reading.

(3) **H.T. Receiver.**—This voltage, normally about 85 volts, is applied to the meter through a dropping resistor of such a value as to give approximately the same reading as L.T.

(4) **H.T. Transmitter.**—A voltage of about 420 is applied in the same manner as the receiver H.T. voltage and also gives approximately the same reading as L.T.

(5) **Drive.**—An indication of whether or not the power amplifier has an exciting voltage applied to the grid is given by the D.C. voltage set up across the cathode resistor in this circuit. This voltage is applied to the meter via a dropping resistor. An indication of aerial loading is also shown by the various degree of meter dip with different taps, etc.

(6) **Aerial.**—This position indicates the best aerial tapping, etc., by a measurement of voltage existing between the aerial terminal and earth. This method is accomplished by feeding a diode via a small variable condenser and inserting the meter in the diode circuit to measure the current flowing. The scale is purely arbitrary, but a compensating condenser is fitted to ensure approximately the same voltage at both ends of the band.

Preliminary Adjustments to Transmitter/Receiver

Transmitter

- (1) Remove transmitter/receiver from case.
- (2) Clip aerial on contact spring (fitted to rear of transmitter indicator lamp holder).
- (3) Fit specified crystals in order of frequency.
- (4) Apply 12 volts D.C. to plug (P) via input socket.
- (5) Switch on (M) (main ON/OFF switch) and (G) (transmitter ON/OFF switch). Allow one minute to elapse before making any adjustments.
- (6) Set metering switch (C) to "A.V.C." position.
- (7) Set channel selector to 1st crystal (lowest frequency).
- (8) Check netting by rotating (K) until (I) indicates approximate crystal frequency (knob (L)—1520–3800 kc/s. band). Depress (E) and move (K) slightly to tune in signal. Observe resonance by rise in meter reading.
- (9) Repeat (7) and (8) with other crystal frequencies.
- (10) Release (E) and rotate metering switch (C) to "AE."
- (11) Return channel selector to first frequency.
- (12) Attach aerial tapping clip (same number as crystal socket in use) to aerial coil. The position of the clip on the coil is dependent on two factors: (i) frequency, and (ii) aerial parameters. A separate section is devoted to the method of determining the position.
- (13) Depress send/receive switch on the handset.
- (14) Rotate aerial tuning control (D) for peak on the meter. Note the meter reading.
- (15) Move the aerial tapping clip progressively, first towards one end of the coil and then towards the other, readjusting aerial tuning control (D) at each point. Leave the clip on the turn giving the highest meter reading. Note setting of (D).
- (16) Adjust aerial metering trimmer C.61 to give a reading of approximately 0.2 mA. on meter.
- (17) Repeat (12)–(15) inclusive on each crystal frequency.

Receiver

- (18) Tune receiver to a weak signal, around 3500 kc/s., using A.V.C. position on metering switch (C).
- (19) Unscrew cap (R.)
- (20) Insert screwdriver in screw slot and adjust trimmer for maximum output or highest reading on meter.
- (21) Replace cap (R.)

Note.—A convenient method exists by which the receiver aerial circuit may be adjusted when a crystal channel of about 3500 kc/s. is fitted to the transmitter. The procedure to adopt is as follows:—

- (22) Set channel selector to required frequency (approximately 3500 kc/s.).
- (23) Depress netting switch (E).
- (24) Tune receiver to crystal oscillator using A.V.C. position on metering switch (C).
- (25) Unscrew cap (R.)
- (26) Insert screwdriver in screw slot and adjust trimmer for highest reading on meter.
- (27) Replace cap (R.)

Determination of Approximate Tapping Position on P.A. Aerial Coil

To facilitate adjustment of the tapping on the P.A. aerial coil a simple form of colour coding is employed. A circuit diagram showing one tap only is given below.

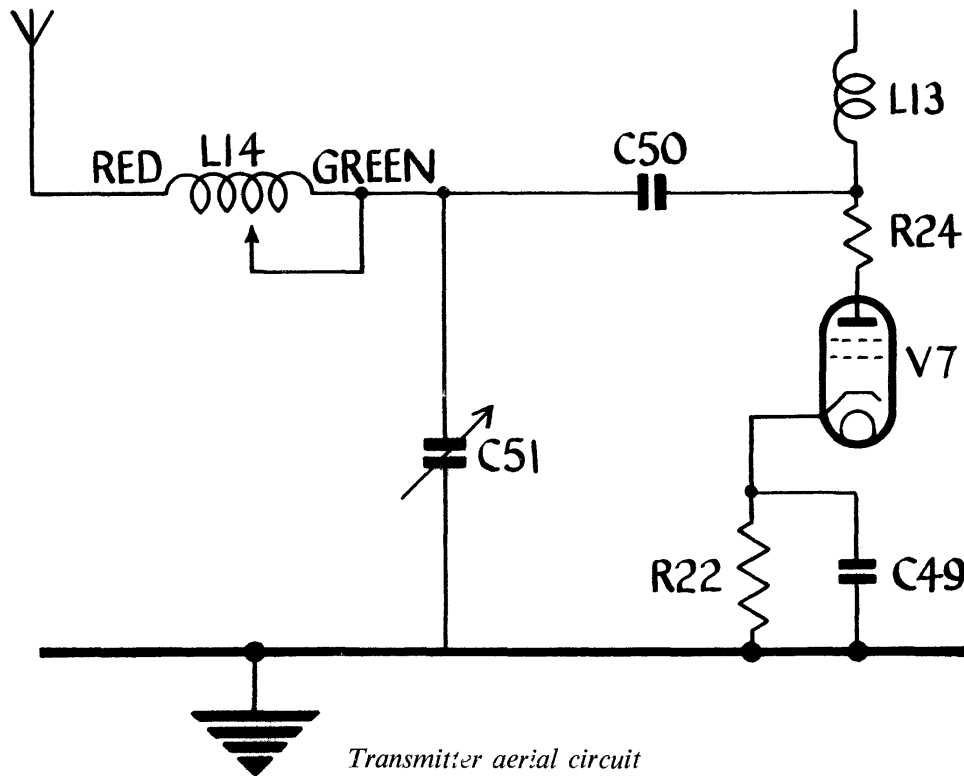

As can be seen from the above circuit the tap is also joined to the anode end of the coil, thus short-circuiting the unused portion. This prevents the possibility of dead spots in the range due to absorption.

It is necessary that care should be taken to avoid operating on a harmonic, and for this reason it is suggested that the following procedure be adopted:—

- (1) Set aerial tuning condenser (D) approximately as below to suit the lowest frequency crystal fitted in the equipment.

3000–3800 kc/s.	10 divisions
2500–3000 „	20 „
2000–2500 „	30 „
1750–2000 „	40 „
1520–1750 „	60 „

- (2) Fit tapping clip at green end of coil. Swing aerial tuning control (D) slightly. Observe meter for any indication of resonance (meter set to “AE”). If there is any

deflection on the meter the tapping clip should be advanced towards "Red" slowly, until the optimum point is determined (see preliminary adjustments). If no indication can be observed the tapping clip should be advanced in steps of several turns until a deflection is noted.

- (3) Switch in circuit the next highest frequency crystal.
- (4) Then, starting at the point determined in (2) by the 1st crystal, advance the tapping clip associated with the new frequency towards the red end in the same manner as that given in (2).
- (5) Repeat with all crystals in order of frequency, starting each tapping clip at the final tapping point of the previous frequency.

Once the first tapping position is found, the subsequent taps may be approximately calculated by the following method:—

- (a) Count the number of turns between the red end and the first tapping clip (lowest frequency).
- (b) Divide the frequency to be set up by the frequency already adjusted (lowest frequency).
- (c) Then divide the number of turns given in (a) by the answer given by (b).
- (d) This figure gives the approximate number of turns between the red end of the coil and the tapping clip to be set up.

Example:

The first frequency of 2000 kc/s. has been set up and the turns between the red end of the coil and the tapping clip have been counted and found to be 45 in number.

Let the next frequency be 3000 kc/s.

Therefore (as given in (b) above),

$$3000 \div 2000 = 1.5$$

Then (as given in (c) above),

$$45 \div 1.5 = 30$$

Therefore, the *approximate* tapping position for the 3000 kc/s. channel is 30 turns from the red end of the coil. A peak should be found at this point and it will then be necessary to move the tap either one way or the other until an optimum is determined.

General

Broadly speaking, the tapping position depends upon two factors:—

- (i) The aerial system.
- (ii) The frequency.

If the aerial system is large and has a high capacity to earth, the tapping point will move towards the red end of the aerial coil or vice versa. Also, as the frequency increases, the tap will move towards the red end.

It will therefore be necessary to ensure an adequate aerial capacity on very small boats in order to tune to the extreme lower frequencies. For the same reason the length of aerial on the larger type of boat should be borne in mind when installing and operating at the extreme higher frequencies. In general, however, it should be possible to operate within reason with any length of wire above 15–20 feet.

Operating Instructions

A. When transmitting and receiving on the same frequency:

- (1) Switch on (M) (main ON/OFF switch) and (G) (transmitter ON/OFF switch). Allow one minute to elapse before making any adjustments.
- (2) Set receiver tuning dial (I) approximately to frequency required by rotating knob (K) (1520–3800 kc/s. band).
- (3) Rotate metering switch (C) to “A.V.C.”
- (4) Set channel selector to required frequency.
- (5) Depress netting switch (E) and slowly rock tuning knob (K) until signal is heard. Tune for peak on meter. Release netting switch (E).
- (6) Rotate metering switch (C) to “AE.”
- (7) Depress send/receive switch on handset.
- (8) Rotate aerial tuning control (D) for peak on meter.
- (9) To transmit depress send/receive switch on handset and speak. To receive—release send/receive switch. Set volume control (J) to suit.

B. When transmitting on different frequency from that received:

- (1) Switch on (M) (main ON/OFF switch) and (G) (transmitter ON/OFF switch). Allow one minute to elapse before making any adjustments.
- (2) Either (a) Set tuning dial (I) by rotating knob (K) to approximate frequency of received signal (1520–3800 band);
or (b) Tune in the desired signal by rotating knob (K).

Note.—Accurate tuning may be achieved by tuning in the desired signal for peak on the meter with metering switch (C) at “A.V.C.”

- (3) Set channel selector to required frequency.
- (4) Rotate metering switch (C) to “AE.”
- (5) Depress send/receive switch on handset.
- (6) Rotate aerial tuning control (D) for peak on meter.
- (7) If method given in (2) (a) was used the necessary calls, etc., must now be made in order to ask the other station to radiate a tuning signal.
- (8) To transmit, depress send/receive switch on handset and speak. To receive—release send/receive switch. Set volume control (J) to suit requirements.

C. Receiver only required.

- (1) Switch on (M) (main ON/OFF switch).
- (2) Set switch (L) to required band.
- (3) Tune in required signal by rotating knob (K). Frequency indicated on dial (I).
- (4) Adjust volume control (J) to suit requirements.

Voltage Analysis

Conditions of measurement: All measurements taken relative to chassis (negative earth).

Receiver: Tuned to 530 kc/s.

Volume control at maximum.

12 volts at input plug.

Avometer Model 7. Under 10 volts on 10-volt scale, over 10 volts on 400-volt scale.

Transmitter: Tuned for maximum aerial current at about 2000 kc/s.

12 volts at input plug.

No modulation.

Avometer Model 7. Under 10 volts on 10-volt scale, over 10 volts on 1000-volt scale.

Receiver

V1. R.F. valve, Mullard DF91.

E_{f_1} 0 V. E_s 46 V.

E_{f_7} 1.35 V. E_a 61 V.

V2. Frequency changer valve, Mullard DK91.

E_{f_1} 0 V. E_s (Osc_a) 47 V.

E_{f_7} 1.35 V. E_a 61 V.

V3. I.F. amplifying valve, Mullard DF91.

E_{f_1} 1.35 V. E_s 46 V.

E_{f_7} 2.7 V. E_a 61 V.

V4. Detector and A.F. amplifying valve, Mullard DAF91.

E_{f_1} 1.35 V. $E_a E_s$ 15 V.

E_{f_7} 2.7 V.

V5. Output valve, Mullard DL92.

E_{f_1} 2.7 V. E_s 61 V.

E_{f_7} 4.05 V. E_a 83 V.

Bias on output valve obtained from filament drop plus line bias.

Other voltages:

Line bias—4 V.

Smoothed H.T.—85 V.

Unsmoothed H.T.—91 V.

Total H.T. current—11.3 mA.

Total L.T. input current—0.375 amperes plus that taken by the dial lamp (usually 0.2 amperes).

[Note.—Numbers given after E_f in all the above valve voltages refer to pin numbering on valve base.]

Transmitter

V6. Master oscillator valve, Type 6V6GT.

E_H	6.0 V.	I_k	5.4 mA.
E_a	155 V.	I_s	0.4 mA.
E_s	40 V.	I_a	5 mA.
E_k	0 V.					

V7. Power amplifier valve, Type 807 or Mullard QV05-25.

E_H	6.0 V.	I_k	45 mA.
E_a	415 V.	I_s	4.85 mA.
E_s	255 V.	I_a	40.15 mA.
E_k	17.5 V.					

V8. Modulation pre-amplifying valve, Type 6Q7GT.

E_H	6.0 V.	I_k	1.75 mA.
E_a	196 V.	I_a	1.75 mA.
E_k	1.75 V.					

V9. Modulator valve, Type 807 or Mullard QV05-25.

E_H	6.0 V.	I_k	45 mA.
E_a	415 V.	I_s	4.5 mA.
E_s	236 V.	I_a	40.5 mA.
E_k	17.5 V.					

Servicing

Dismantling Individual Units

Receiver

To obtain access to the underside of the chassis:

- (a) Lay the complete set on its side.
- (b) Unplug the aerial lead from the underside of the transmitter unit.
- (c) Remove screw holding tag end of bypass condenser (located on side screen).
- (d) Remove the wavechange and tuning knobs.
- (e) Unscrew four fixing screws "V." (Fig. 1.)

Note.—These screws are semi-captive due to being mounted in rubber, and should therefore be unscrewed no more than is necessary to release the unit.

- (f) Remove the screw from the black lead connecting the receiver and receiver vibrator unit together.
- (g) Carefully pull the receiver towards the back of the set, pushing if necessary on the tuning and wavechange spindles from the front of the set. When the set has been withdrawn half-way, raise the rear of the chassis slightly towards the transmitter unit to avoid damaging the scale back plate.
- (h) Remove base cover.

The leads connecting the receiver to the vibrator unit, the loudspeaker and the volume control are sufficiently long to permit servicing without unsoldering the leads connecting one unit to another.

If the removal of the complete receiver unit is required the following additional operations should be performed.

- (i) Remove the five leads connected to the tag board on the smoothing choke (vibrator unit). (See Fig. 4 for connections.)
- (j) Disconnect the loudspeaker (at loudspeaker end of connecting lead).
- (k) Either disconnect the volume control from the screened cable or remove the knob and locking nut on the volume control, thus allowing the control to be withdrawn with the unit.

To facilitate servicing, the side panels on the receiver unit can be removed by unscrewing three or four screws per side. This allows ready access to the valve holder connections. It is also possible to remove one of these side panels with the set in position, and thus any minor repair to the R.F. end of the receiver may be made without removing the receiver unit from the main assembly.

Vibrator Unit

To remove the vibrator unit:

- (a) Lay the complete set on its side.
- (b) Unscrew four fixing screws (W). (Fig. 1.)

Note.—These screws are semi-captive due to being mounted in rubber, and should therefore be unscrewed not more than is necessary to release the unit.

- (c) Remove the screw from the black lead connecting the receiver and receiver vibrator unit together.

- (d) Carefully pull the vibrator unit towards the back of the set.
- (e) Remove the bottom cover.

Leads of adequate length connect the vibrator unit to the receiver and to the connection plate, etc. It should be possible to make all repairs necessary with the unit connected in this fashion.

If complete removal is required, the following additional operations should be performed.

- (f) Remove the five leads connected to the tag board on the smoothing choke (vibrator unit). (See Fig. 4 for connections.)
- (g) Remove eight leads connected to the input tag board. (Fig. 5.) These leads form part of the inter-unit cable-form.

As with the receiver unit, it is possible, by removing three screws per side, to allow further access to the underside of the vibrator unit. It is also possible to remove one of these side panels with the unit in position and thus permit inspection and repair of some of the filter assembly.

Transmitter

Much of this unit can be serviced without removing any part of the equipment. If, however, the faulty component is in an inaccessible part of the unit, one of two methods should be adopted.

- (a) The first consists of the removal of either or both of the receiver units (receiver or receiver vibrator unit) in the manner given in the early part of this section. This gives access to the underside of the transmitter chassis.
- (b) The second method is necessary when replacing toggle switches and in cases of extensive repair. Here the top chassis should be removed in the manner given below:
 - (i) Lay the complete unit on its side with the crystal holder at the bottom.
 - (ii) Detach the receiver aerial socket from the plug on the underside of the transmitter unit.
 - (iii) Unsolder the aerial lead connecting the aerial relay to the aerial connector spring.
 - (iv) Unsolder the flexible lead from the transmitter indicator lamp.
 - (v) Remove three pointer knobs—airial tuning, channel selector and metering.
 - (vi) Loosen and remove fixing nuts from channel selector and metering switch.
 - (vii) Undo five screws (Z). (Fig. 3.)
 - (viii) Remove connecting clips from terminals at the back of the meter.
 - (ix) Gently ease the transmitter unit towards the back of the set: at the same time remove the metering switch from the hole in the front panel.

The details given in (i) to (ix) permit the transmitter unit to be swung clear of the set. If it must be detached completely it is necessary to unsolder the leads at the connection boards shown in Fig. 6.

The connections to the transmitter power unit tag strips are shown in Fig. 7. In normal circumstances it will be unnecessary to remove these connections.

I.F. Circuits — General

Output impedance of the receiver: 3 Ω .

The wavechange switch should be set to the lower frequency band and the gang condenser set to maximum capacity.

I.F. Circuits

Two I.F. transformers are used in the receiver, the first being overcoupled and the second being critically coupled. In order to preserve symmetry the following trimming procedure should be adopted.

- (a) Connect the signal generator between the grid of the frequency changer valve and earth, or between the centre section stator of the gang condenser and earth via a buffer condenser of approximately 0.01 μF .
- (b) Set signal generator to 465 kc/s.
- (c) Damp the secondary of the 1st I.F. transformer by connecting a 0.05 μF . and 10,000 ohm resistor in series between the grid of V3 and earth. Trim the primary of the 1st I.F. transformer for maximum audio output.
- (d) Damp the primary of the 1st I.F. transformer as in (c). Trim the secondary of the 1st I.F. transformer.
- (e) Repeat (c) and (d).
- (f) Remove the damping circuit and trim the primary and secondary of the 2nd transformer for maximum audio output.

The input should be less than 700 μV . at 30 per cent. modulation (400 cps.) for 50 mW. output at the loudspeaker.

The bandwidth should be checked at 2 times down in output (6 db.) and 100 times down in output (40 db.). It should be measured relative to centre frequency.

Limits.	6 db.	$\pm 3.0 - 4.0$ kc/s.
	40 db.	$\pm 10 - \pm 12$ kc/s.

[*Note.*—The approximate input required at the grid of the I.F. valve for 50 mW. output (loudspeaker) is 20 mV. at 30 per cent. modulation, 400 cps.]

R.F. Circuits — General

Dummy antenna—100 ρF . and 10 Ω . (See Fig. 8.)

[*Note.*—If the signal generator is of 10 Ω output impedance this should constitute the 10 Ω required in the dummy antenna. If the signal generator output impedance is of a different value, it must be padded to suit.]

The output from the signal generator should be fed, via the dummy antenna, to the aerial lead of the receiver, and it is necessary to short-circuit the aerial trimming condenser (C1) in order to align correctly the aerial circuit.

Output impedance of receiver: 3 Ω .

Lower Frequency Band (530-1600 kc/s)

- (1) Adjust the pointer with the vanes of the gang condenser fully meshed. The vanes are aligned by checking “flatness” of the rear section with the straight edge of a piece of bakelite, card or other material. The pointer should coincide with the centre of the “kc/s” and “m” blocks on the scale.

- (2) Rotate the pointer 180° from maximum capacity, i.e. when the pointer should again coincide with the “kc/s” and “m” blocks on the scale.
 [*Note.*—These positions will in future be referred to as maximum and minimum capacity respectively.]
- (3) With the gang condenser at minimum, adjust MW oscillator trimmer condenser C15 to 1600 kc/s. signal.
- (4) With the gang condenser at maximum, adjust MW oscillator coil L5 to 530 kc/s.
- (5) Repeat (3) and (4) until correctly adjusted.
- (6) Tune in 1500 kc/s. signal. Adjust condensers C9 and C2 for maximum output.
- (7) Tune in 600 kc/s. signal and adjust coils L4 and L1 for maximum output.
- (8) Repeat (6) and (7) until correctly adjusted.
- (9) Check signal input required at 1500 kc/s. This should not be greater than 3 μ V. (30 per cent. modulation, 400 cps.).
- (10) Repeat (9) at 1000 kc/s. The input should not be greater than 5 μ V. (30 per cent. modulation, 400 cps.).
- (11) Repeat (9) at 600 kc/s. Input not to be greater than 12 μ V. (30 per cent. modulation, 400 cps.).
- (12) The signal input required at either image (2nd channel) or intermediate frequency when received on any of the three frequencies—1500, 1000 and 600 kc/s.—should be at least 50 db. down (approximately 300 times down) on signal input at the correct frequency.

Higher Frequency Band

- (1) With the gang condenser at minimum, adjust MSW oscillator trimmer condenser C18 to 3800 kc/s.
- (2) With the gang condenser at maximum, adjust MSW oscillator coil L6 to 1520 kc/s.
- (3) Repeat (1) and (2) until correctly adjusted.
- (4) Tune in 3500 kc/s. signal. Adjust condensers C8 and C3 for maximum output.
- (5) Tune in 1700 kc/s. signal and adjust coils L3 and L2 for maximum output.
- (6) Repeat (4) and (5) until correctly adjusted.
- (7) Check the signal input required at 3500 kc/s. This is not to be greater than 4 μ V. (30 per cent. modulation, 400 cps.).
- (8) Repeat (7) at 2600 kc/s. when the input is not to be greater than 10 μ V. (30 per cent. modulation, 400 cps.).
- (9) Repeat (7) at 1700 kc/s. when the input is not to be greater than 14 μ V. (30 per cent. modulation, 400 cps.).
- (10) The signal input required at image frequency (2nd channel) when received on any of the three frequencies—3500, 2600 and 1700 kc/s.—should be at least 45 db. down (approximately 170 times down) on the signal input at the correct frequency.
- (11) The signal input required at intermediate frequency when received at any of the three frequencies—3500, 2600 and 1700 kc/s.—should be at least 80 db. down (10,000 times down) on the signal input at the correct frequency.

Receiver — General Data

Audio Response

Measured at 750 kc/s.

Modulation to be kept at 30 per cent.

Input from signal generator to be 1 mV.

Volume control to be retarded for approximately 35 mW. output.

Loudspeaker in circuit.

Response (relative to 400 cps.):

100 cps.	— 8 db.	} approximately
200	— 1 „	
1 kc/s.	+ 1 „	
2 „	— 1 „	
4 „	— 8 „	
6 „	— 17 „	

Audio Amplifier Sensitivity

Input required to audio amplifier grid (V4) for 50 mW. output (400 cps.): 0.2 volt.

Input required to output valve grid (V5) for 50 mW. output (400 cps.): 3 volts.

A.V.C. Characteristic

For a change of 60 db. in the input from the signal generator at 750 kc/s., the audio should not change more than 14 db. It is necessary to adjust the audio gain control on the receiver to prevent overloading at maximum signal input (i.e. 0.1 volt).

Calibration

All points on the scale should be within ± 1 per cent. of frequency.

Transmitter — General Data

Dummy antenna: 200 μ F. in series with 10 Ω . (See Fig. 9.)

All measurements taken with 12 volts input at socket.

Modulation Frequency Response

- (a) Loosely couple the Y plate of an oscilloscope to the aerial side of dummy antenna.
- (b) Switch the channel selector to a convenient frequency (preferably around 2000 kc/s.).
- (c) Adjust transmitter aerial circuit in accordance with setting up procedure on installation.
- (d) Connect the beat frequency oscillator to the input of the microphone transformer by the network shown in Fig. 10.
- (e) Apply a voltage from the beat frequency oscillator for 90 per cent. modulation at 1300 cps. (Approximate wave shape shown in Fig. 11.)
- (f) The wave shape should agree generally with that shown.
- (g) The output from the beat frequency oscillator should be between 0.3 and 0.6 volts.
- (h) Apply 30 volts at 5000 cps. Note modulation depth by marking the peak and trough of the wave-form on the edge of a piece of card.
- (i) Change frequency to 3500 cps. Reduce input until peak and trough coincide with that marked on the card. Input should be greater than 3.0 volts.
- (j) Change frequency to 1300 cps. Reduce input until peak and trough coincide with that marked on the card. Input should be less than 0.3 volt.
- (k) Change frequency to 200 cps. Reduce input until peak and trough coincide with that marked on the card. Input should be less than 0.75 volt.

Aerial Current

At any frequency in the band 1600 kc/s. to 3700 kc/s. it should be possible to obtain a current of not less than 0.9 ampere flowing through the dummy antenna.

Electrical Interference

(Ignition, Dynamo and Auxiliary Equipment)

Ignition

To reduce ignition interference the following points should be observed:—

- (a) Instal the transmitter/receiver as far as possible from the engine.
- (b) Try to arrange the aerial system so that the lead-in avoids the metal work associated with the engine. Also it should be kept as far as possible from the ignition wiring.
- (c) Avoid earthing the equipment to the engine mounting, etc.
- (d) Do not run the aerial lead-in parallel or close to any lighting circuits.

In the event of excessive ignition noise after the above points have been observed, it may be necessary to try one or more of the following:—

- (a) Coil Ignition.
 - (i) If the coil is not mounted on the engine block, either a heavy braid lead should earth it to the engine or, if possible, the coil should be moved to a convenient place on the block. Interference due to the above is usually caused by a long earth path or radiation from the connection between the coil and distributor. It is therefore obvious that the positioning of the coil is the most important factor.
 - (ii) Fit a 1 μ F. condenser between the “SW” terminal of the coil and earth at a point that provides a minimum length of lead. This is usually on the coil bracket itself.
 - (iii) Fit a suppression resistor in the coil-to-distributor lead as close to the distributor as possible. This resistor should preferably be one of the screw-in type of about 10,000 ohms in value. It is usual to obtain a reduction of between 5 and 10 times by this method.
 - (iv) If the above methods do not effect a complete cure a further reduction may be obtained by shortening the plug leads to the minimum length necessary. Re-routing the leads so as to shield them by the engine also helps in many cases.
 - (v) Suppression by the insertion of resistors (approx. 10,000 ohms) in each plug lead at the point nearest to each plug may be necessary in a few cases, while in extreme cases of bad interference this 10,000 ohms resistor may provide more suppression if divided into two resistors of 5000 ohms each, one being fitted to the plug end of the lead and the other to the distributor end.
 - (vi) It is possible to obtain ignition lead having a distributed resistance about its length. This effects a certain improvement over the method outlined in paragraph (v).
 - (vii) Other methods of suppression are possible but can materially affect engine performance, and therefore should not be attempted without consultation with the manufacturers of the motor. These methods include screening of ignition cables, etc.

(b) Magneto Ignition.

The points generally outlined in paragraphs (iv) to (vii) above apply equally well with magneto ignition.

Dynamo

The interference set up by the dynamo can be distinguished readily by the rhythmic crackling which becomes a medium pitched "whirr" as the engine is speeded up. Methods of suppression by the fitting of condensers, etc., are well known.

Auxiliary Equipment

Small Motors.—Fit a 0.5 to 1.0 μ F. condenser between each brush and earth with a minimum length of lead. If the noise still persists, a small R.F. choke in either or both leads might prove advantageous.

In the case of totally enclosed machines it may be necessary to reduce the capacities required in order to accommodate them inside the cover. Also, it may prove possible to use only one condenser across the brushes.

An important point that should not be forgotten is that a better earth connection to the framework of small motors often decreases the noise considerably.

Contact Breakers (including horns, thermostats, etc., but excluding ignition switching).—In cases of interference caused by the making and breaking of reactive circuits, a small condenser (the value dependent upon conditions, etc.) connected across the contacts will usually reduce the annoyance value of such interference. It may be necessary to include a small R.F. choke in the lead going to the contact breaker to prevent radiation from the wiring.

Miscellaneous.—In a boat having a number of ancillaries, a considerable amount of interference is often radiated from the wiring, especially wiring feeding cabin lights, riding lights, etc. It is therefore often necessary to bypass the wiring at the source of trouble with a suitable condenser or condensers to prevent radiated interference feeding into the aerial system.

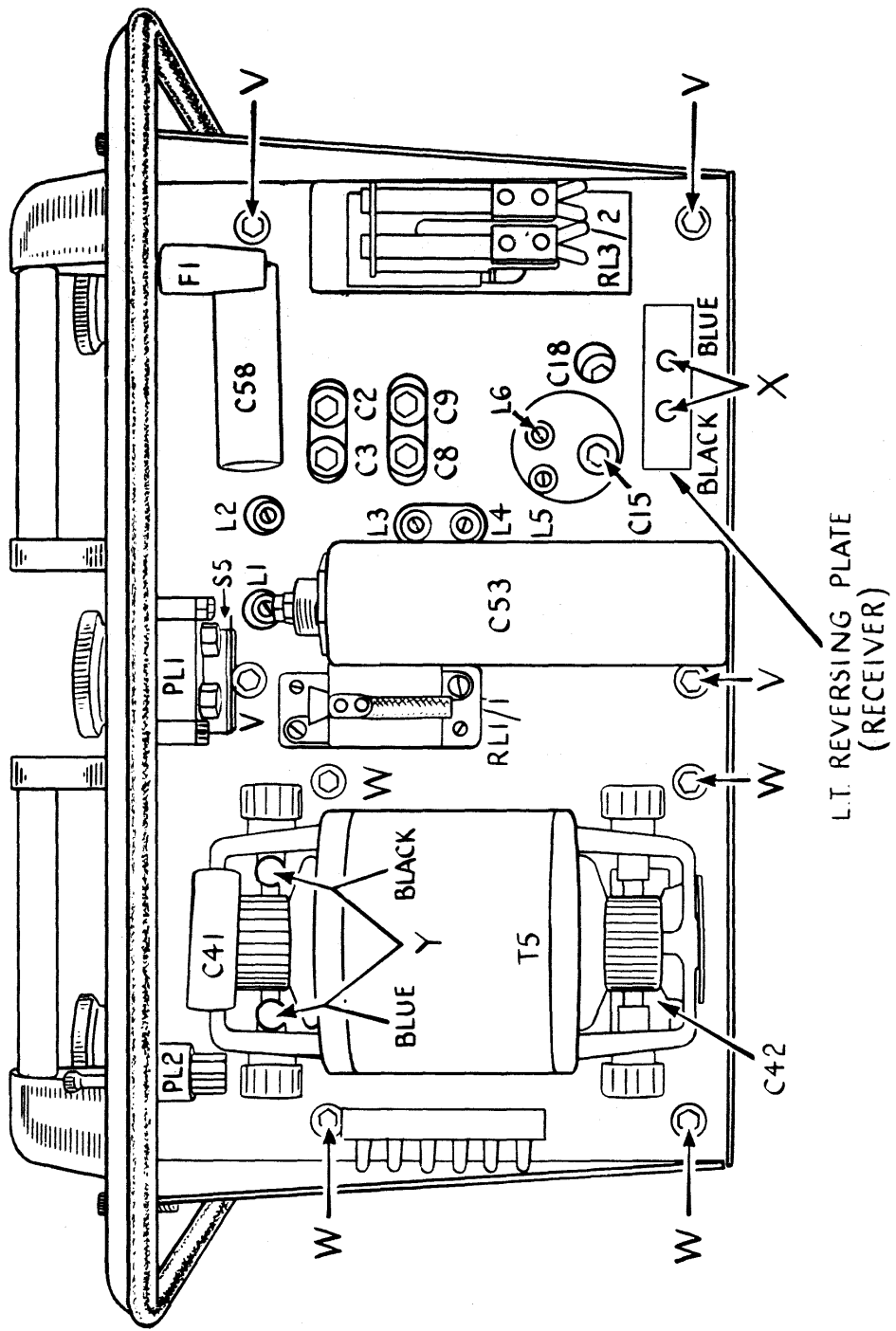

L.I. REVERSING PLATE
(RECEIVER)

Fig. 1

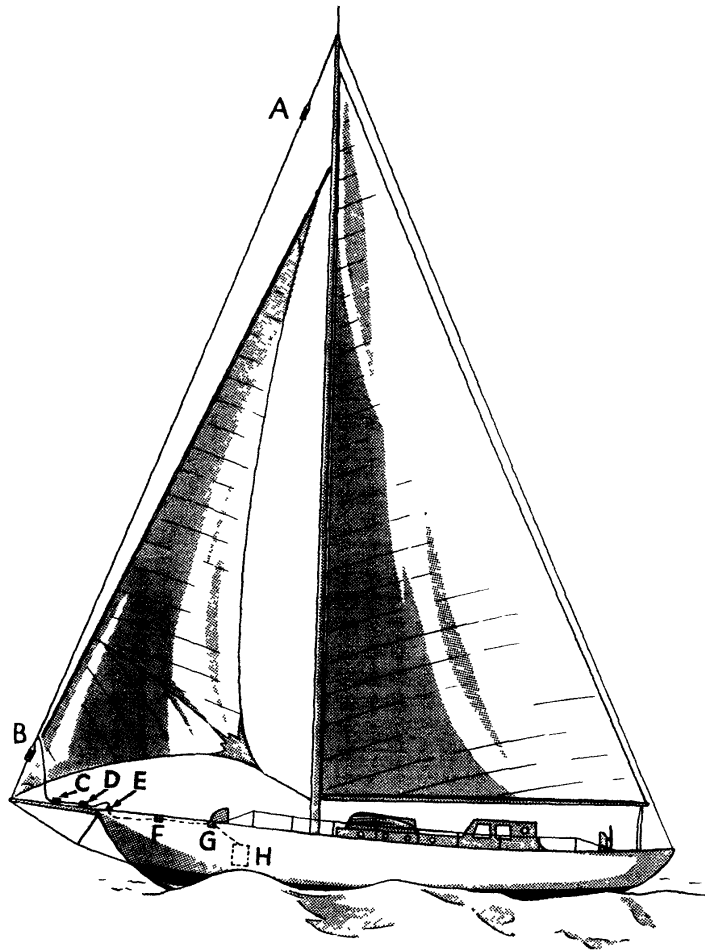

Fig. 2A

The use of the main mast stay as an aerial system on sailing yachts

Mast main stay wire (steel) replaced by steel and copper wire of equivalent strength. Insulator fitted at points A and B.

Lead-in attached at point B; this lead-in is carried by the insulators C and D mounted on the topside of the bowsprit and then taken through the hull (via suitable insulator) to the transmitter/receiver H. Insulators F and G should be fitted to the underside of the deck to support the lead-in and should be totally enclosed in trunking.

An earthed lead of copper braid or wire of not less than 7/0.056 inches diameter should connect the set to the nearest possible earthing point (keel, etc.).

Note.—Insulators in main stay wire must be of the interlock and power line type.

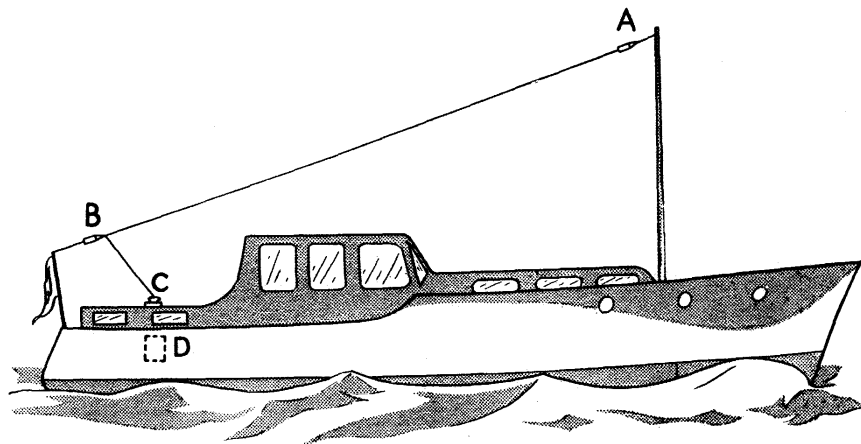

Fig. 2B
Aerial system for motor launch

- A and B. Shell type insulators.
- C. Deck insulator.
- D. Transmitter/receiver. (Earthed with copper braid as with yacht installation.)

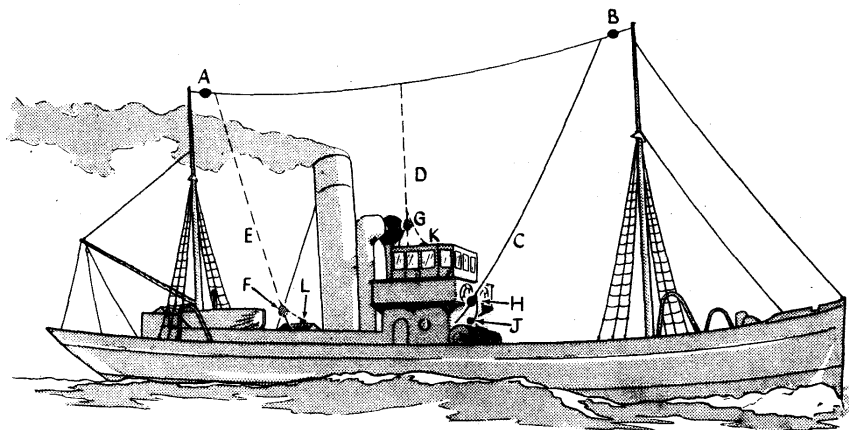

Fig. 2C
Typical trawler showing three alternative aerial systems

Heavy duty shell type insulators are fitted at points A and B. The lead-in is arranged to suit the positioning of the transmitter/receiver and may take the form of an inverted "L" type aerial as shown in the diagram by C and E, or a "T" type aerial as shown at D.

With all types of aerial it is necessary to fit strain wires and these should be insulated from the aerial as shown at F, G and H.

Deck insulators are fitted at either J, K, or L.

Earthing of the set is accomplished in a similar manner to that given with the yacht installation.

Whenever the lead-in approaches to within 6 feet of the deck, trunking must be fitted to prevent the crew touching the aerial.

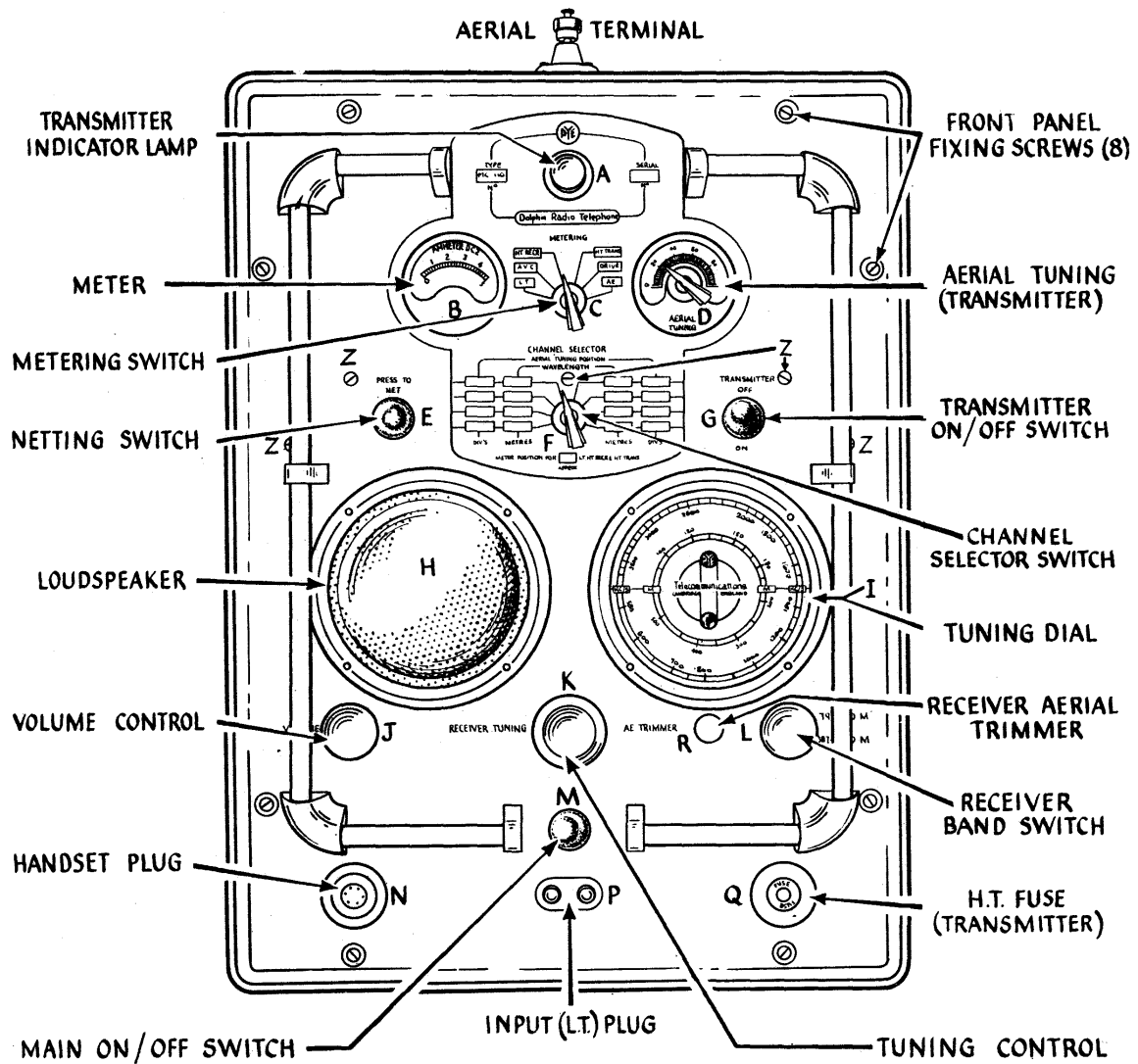

Fig. 3

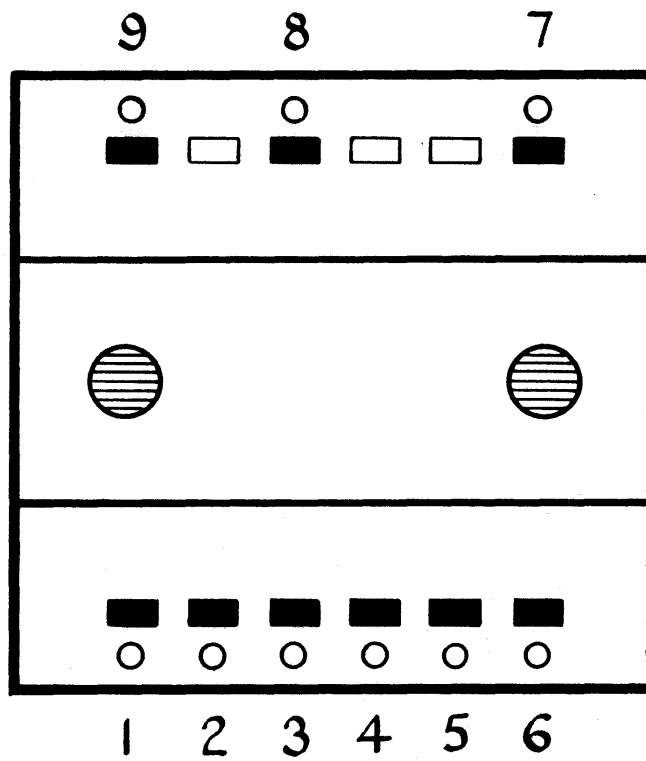

Fig. 4

Tag No.	Colour coding	Connection
1	—	Receiver H.T. + (unsmoothed)
2	Red	Receiver H.T. + (smoothed)
3	—	Netting (H.T.)
4	Orange	Receiver V1 and V3 screens
5	Brown	Receiver H.T. —
6	—	Receiver L.T. + (unfiltered)
7	—	Receiver L.T. + (unfiltered)
8	Blue	Receiver L.T. + (filtered)
9	Black	Receiver L.T. — (filtered)

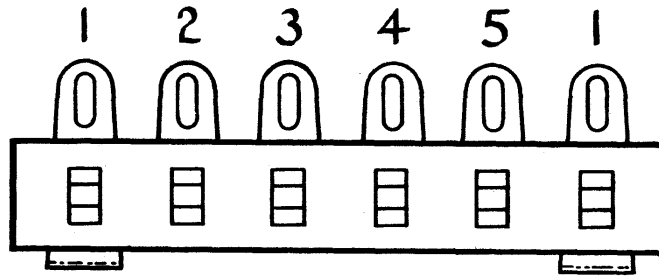

Fig. 5

Tag No.	Colour coding	Connection	Connected to
1	Black	Receiver L.T. -	Fig. 6/6
2	Blue	Receiver L.T. +	Fig. 6/1
3	Pink	Receiver V1 and V3 screens	Fig. 6/4
4	Orange	Netting switch	Fig. 6/11
5	White	Receiver H.T. +	Fig. 7/7 Fig. 6/3

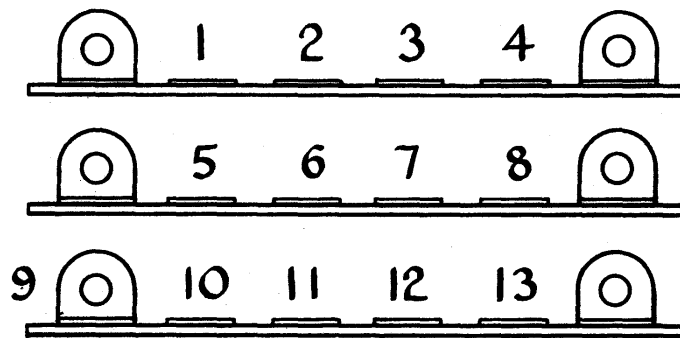

Fig. 6

Tag No.	Colour coding	Connection	Connected to
1	Blue	Receiver L.T. +	Fig. 5/2
2	Orange	Transmitter indicator lamp	Fig. 7/2
3	White	Receiver H.T. +	Fig. 5/5 Fig. 7/7
4	Pink	Receiver V1 and V3 screens	Fig. 5/3
5	Green	Transmitter L.T. ± (heaters)	Fig. 7/4
6	Black	Receiver L.T. -	Fig. 5/1
7	Mauve	Transmitter L.T. ± (switch)	Fig. 7/8
8	Red	Transmitter H.T. +	Fig. 7/1
9	Black	Microphone (earth)	PL2 pin 3
10	Brown	Microphone (hot)	PL2 pin 4
11	Orange	Netting switch	Fig. 5/4
12	Pink	Relay (M.O. H.T. +)	Fig. 7/6
13	Yellow	Relay energising coil	Fig. 7/3

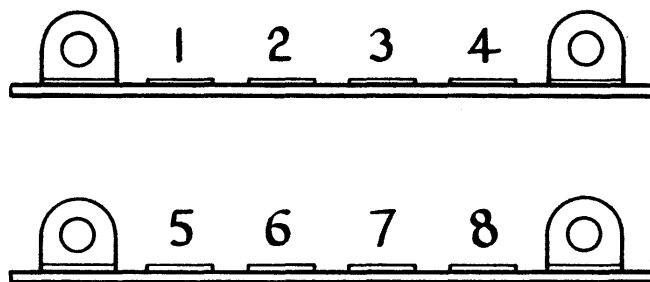

Fig. 7

Tag No.	Colour coding	Connection	Connected to
1	Red	Transmitter H.T. +	Fig. 6/8
2	Orange	Transmitter indicator lamp	Fig. 6/2
3	Yellow	Relay energising coil	Fig. 6/13
4	Green	Transmitter L.T. \pm (heaters)	Fig. 6/5
5	Blank	Blank	Blank
6	Pink	Relay (M.O. H.T. +)	Fig. 6/12
7	White	Receiver H.T. +	Fig. 5/5
8	Mauve	Transmitter L.T. \pm (switch)	Fig. 6/3
			Fig. 6/7

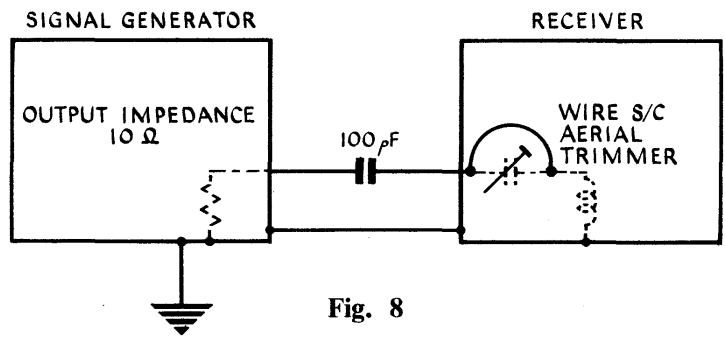

Fig. 8

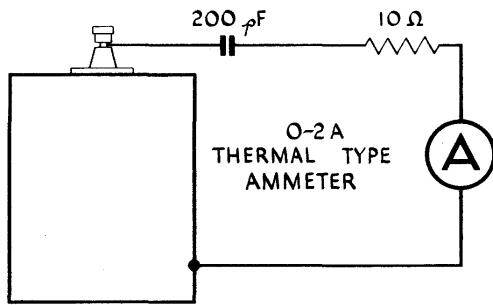

Fig. 9

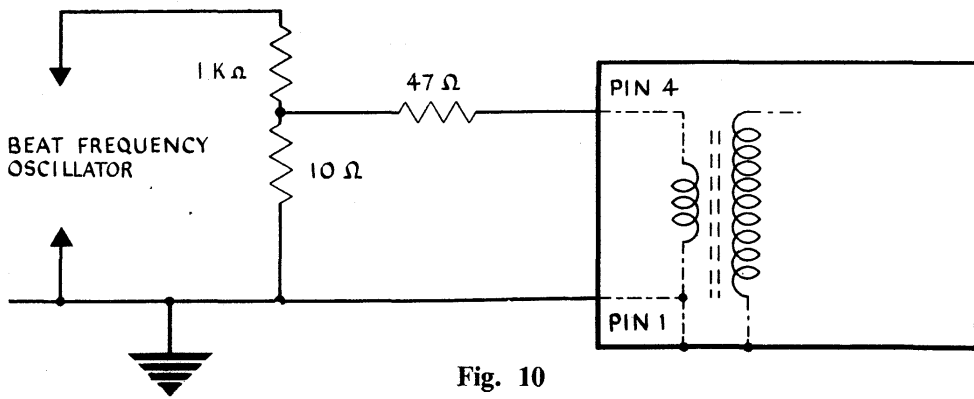

Fig. 10

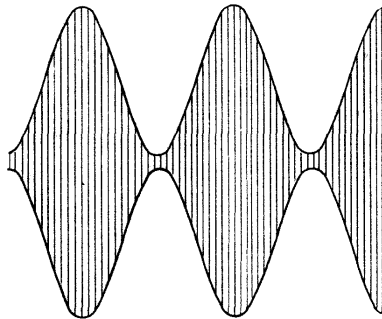

Fig. 11

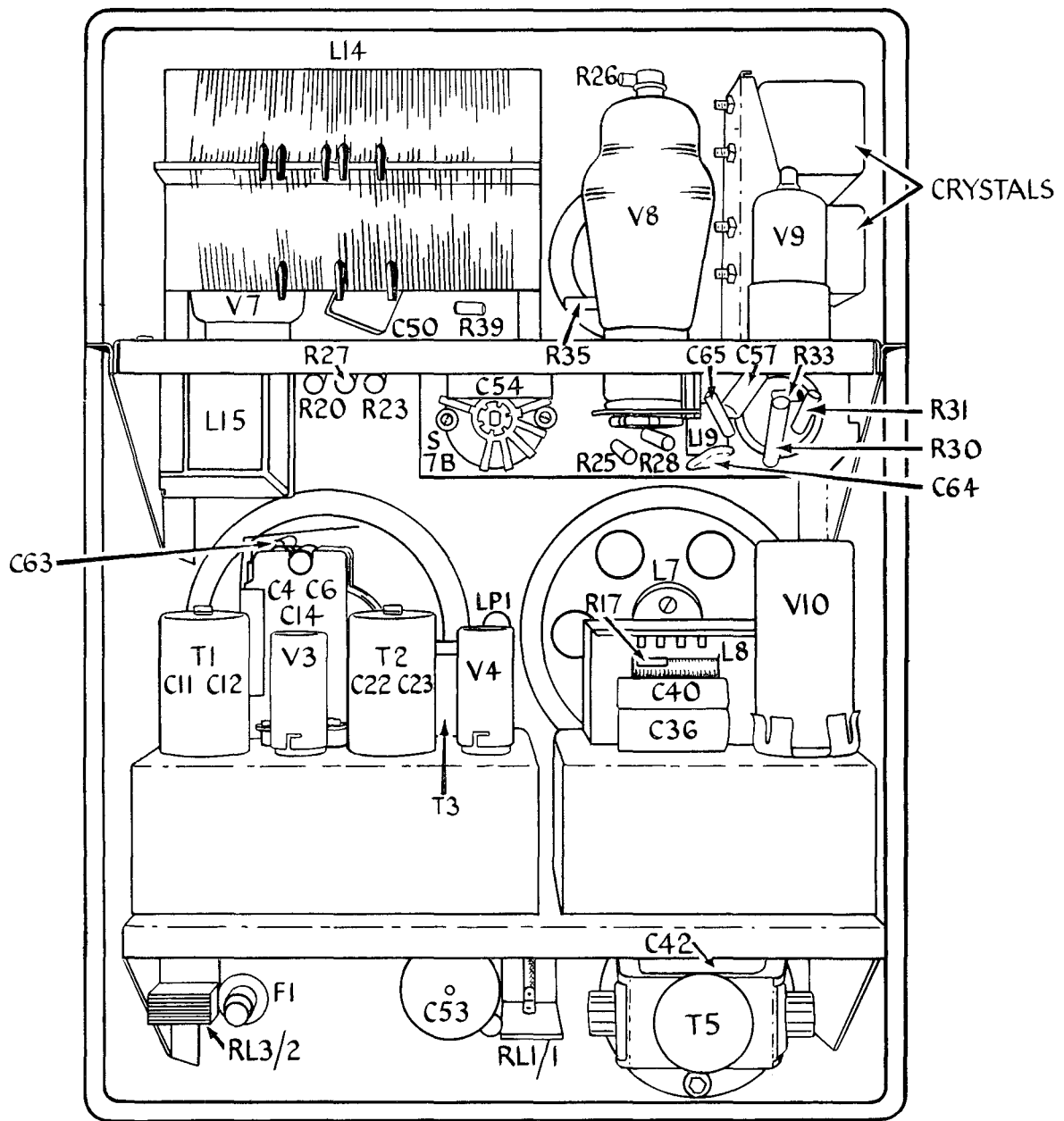

Fig. 12

Rear View of Transmitter/Receiver

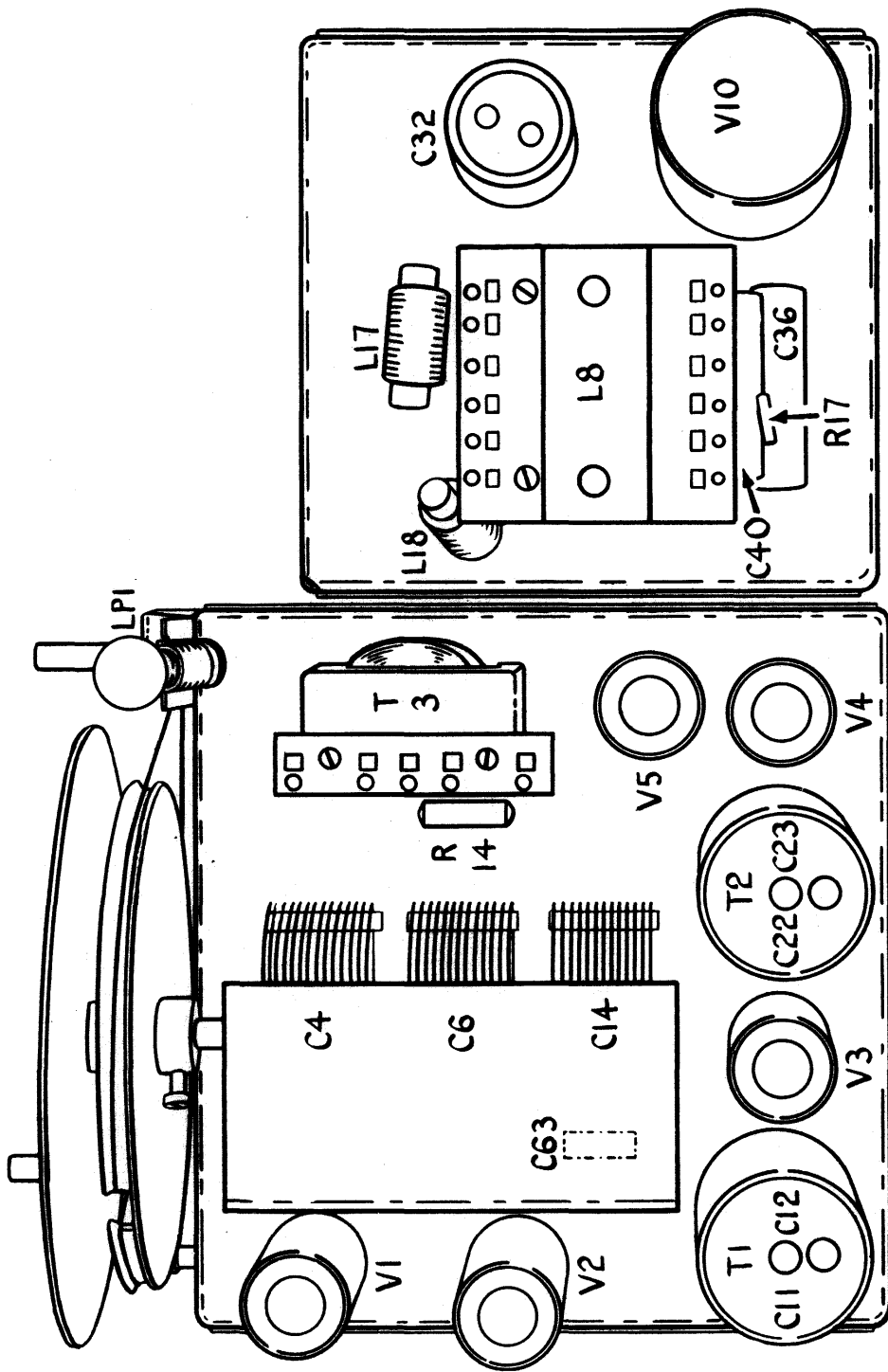
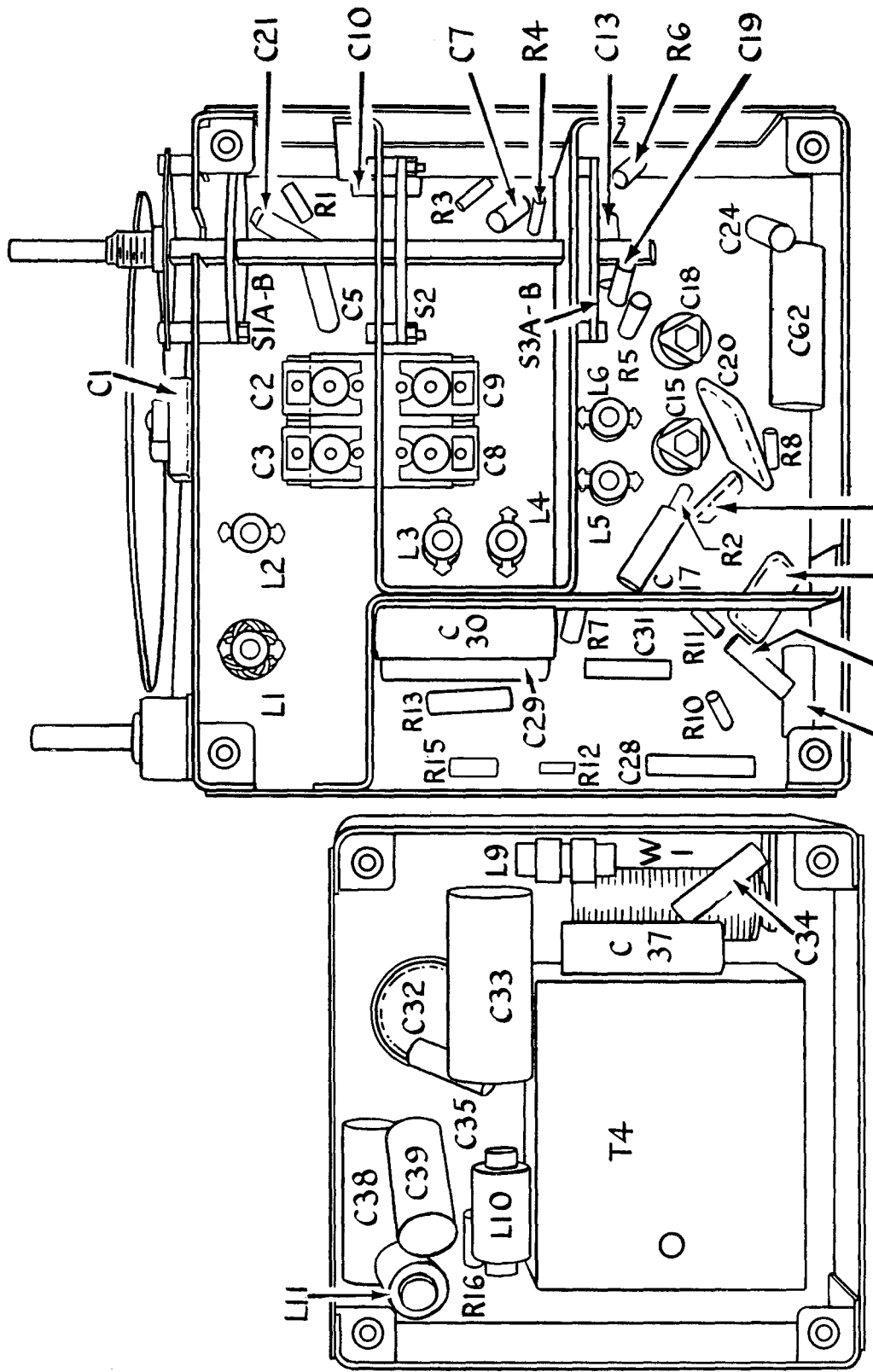

Fig. 13

Top view of receiver and vibrator power unit



C26 C27 C25 C16

Fig. 14

Bottom view of receiver and vibrator power unit

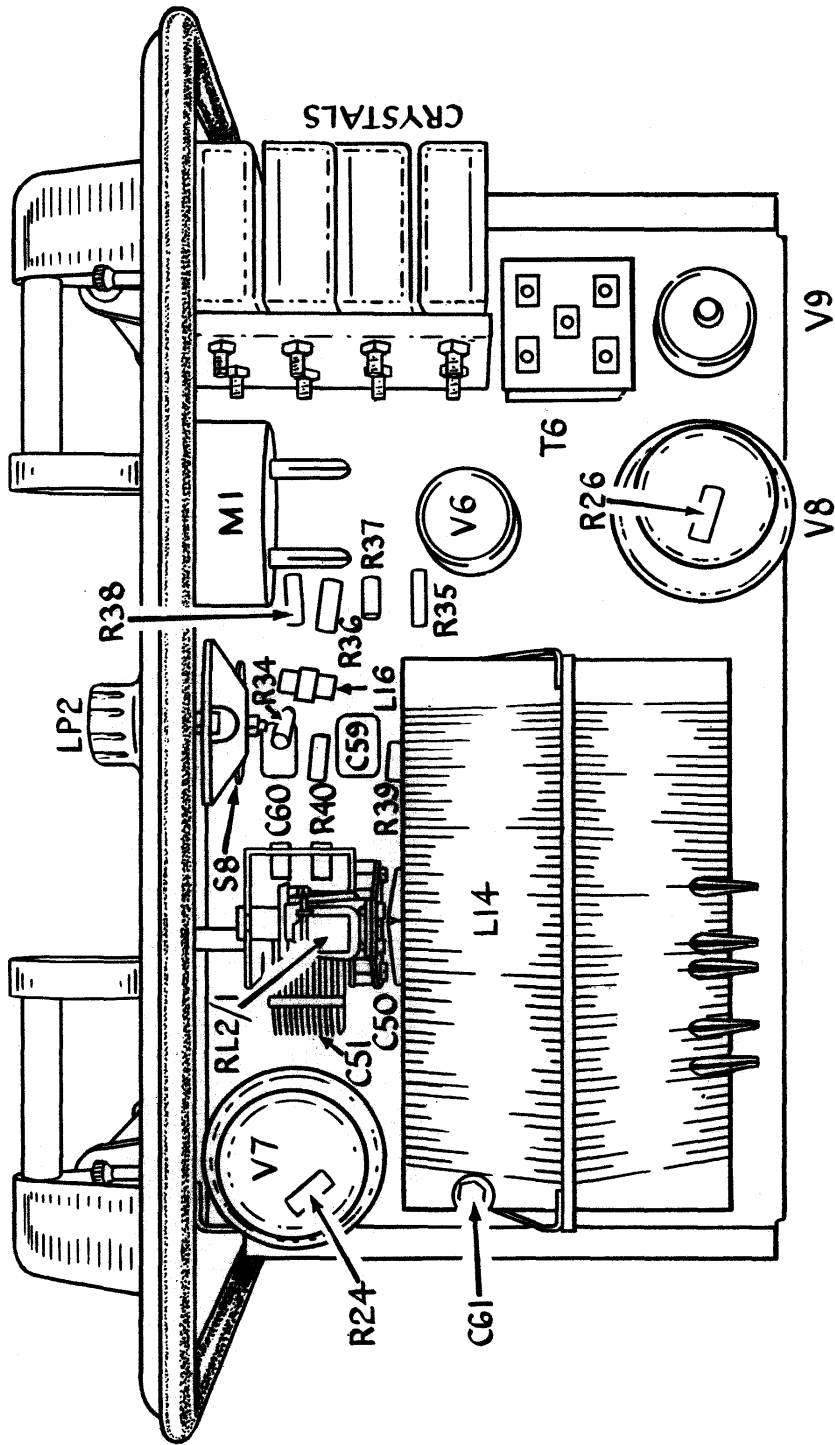

Fig. 15

Top view of transmitter

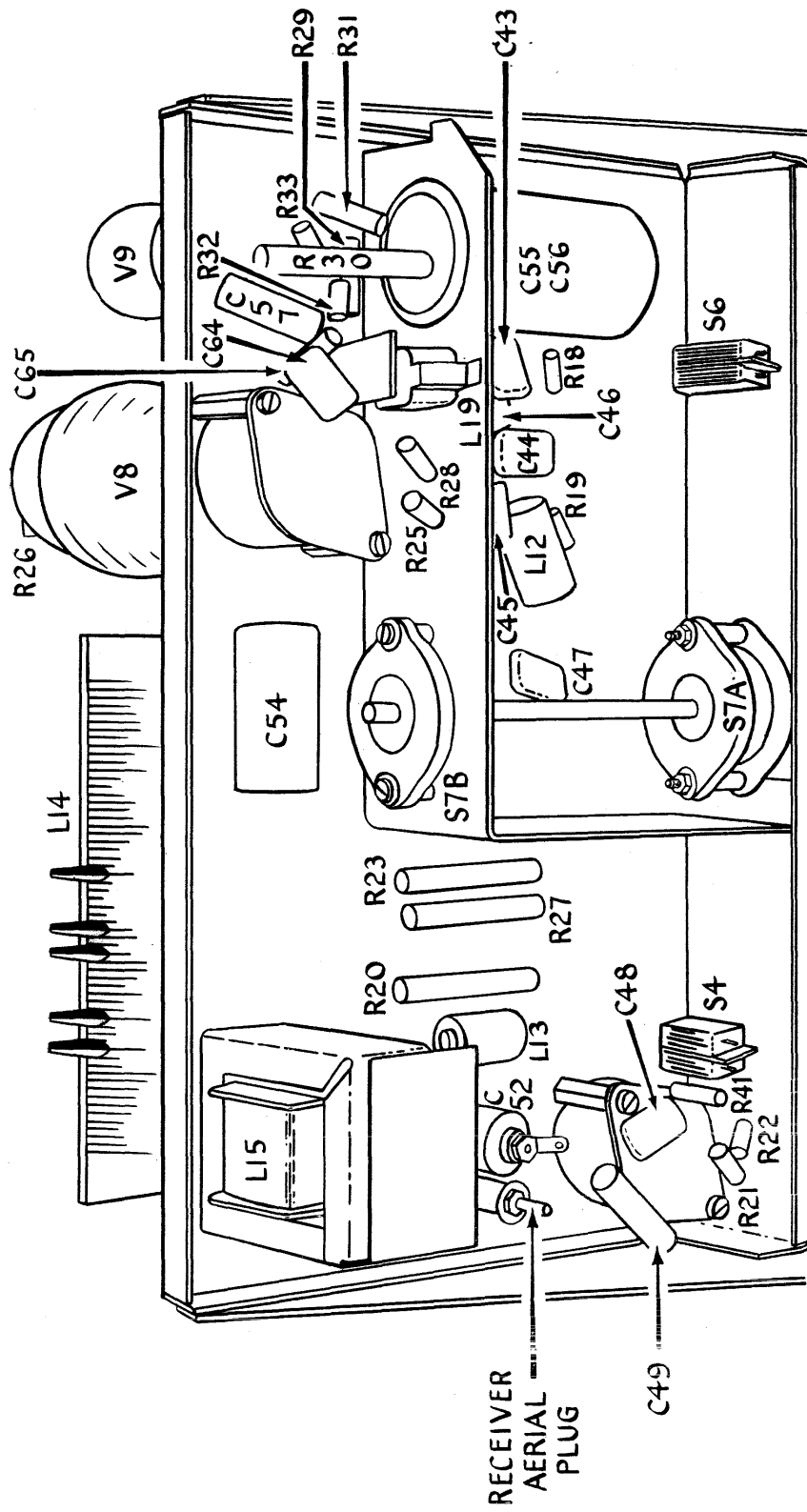

Fig. 16

Bottom view of transmitter

MODIFIED VERSION OF DOLPHIN 6 VOLT OPERATION

The following alterations to the 12 volt Dolphin are made in the modified Dolphin for 6 volt operation, and the code list beneath the circuit diagram should be amended accordingly.

Circuit Indication	RESISTORS	Ref. No.	Circuit Indication	RELAYS	Ref. No.
R13	18 Ω $\frac{1}{2}$ w. \pm 10%	670497	RL1/1	(a) Transmitter Rotary Transformer Relay ..	703230
R16	680 Ω $\frac{1}{2}$ w. \pm 20%	670391	RL2/1	(a) Aerial Changeover Relay	703305
R29	DELETED	—	RL3/2	Transmit-Receive HT Relay	703119
R35	15 K Ω $\frac{1}{2}$ w. \pm 5%	670775			
	TRANSFORMERS			MISCELLANEOUS	
T4	Receiver Vibrator Transformer	770157	LP1	Receiver Dial Lamp, 6.5 v., 0.3 A.	700499
T5	Transmitter Rotary Transformer (HT)	770418	LP2	Transmitter Indicator Lamp, 6.5 v., 0.3 A.	700499
				VALVES	
			V10	6 v. Non-Synchronous 4-Pin Vibrator	701103

NOTE.—TRANSMITTER VALVES WIRED IN PARALLEL (ONE SIDE EARTHED)

Circuit Indication	CONDENSERS	Ref. No.	Circuit Indication	INDUCTANCES	Ref. No.	Circuit Indication	VALVES	Ref. No.
C1	350pF max. (approx.) Multi-plate Trimmer	800081	L1	M.W. (530-1600 kc/s.) Aerial Coil	780317	V1	Mullard DF 91 (Equivalent to Amer. 1T4)	860052
C2	3-50pF Postage Stamp Type Trimmer	800081*	L2	M.S.W. (1520-3800 kc/s.) Aerial Coil	780318	V2	Mullard DK 91 (Equivalent to Amer. 1R5)	860051
C3	3-50pF Postage Stamp Type Trimmer	800015*	L3	M.S.W. (1520-3800 kc/s.) Anode Coil	780320	V3	Mullard DF 91 (Equivalent to Amer. 1T4)	860052
C4	532pF Swing Gang Condenser (Section 1)	800015*	L4	M.W. (530-1600 kc/s.) Anode Coil	780319	V4	Mullard DAE 91 (Equivalent to Amer. 1S5)	860049
C5	100pF Ceramicon	666520	L5	M.S.W. (530-1600 kc/s.) Oscillator Coil	780321	V5	Mullard DL 92 (Equivalent to Amer. 354)	860050
C6	532pF Swing Gang Condenser (Section 2)	800015*	L6	M.S.W. (1520-3800 kc/s.) Oscillator Coil	780322	V6	6V6 GT	860133
C7	47pF Ceramicon	666513	L7	Loudspeaker Speech Coil	850032	V7	807	860035
C8	3-50pF Postage Stamp Type Trimmer	800095	L8	H.T. Smoothing Choke (Receiver)	790108	V8	807	860035
C9	3-50pF Postage Stamp Type Trimmer	666520	L9	H.T. R.F. Filter Choke "A" (Receiver)	790046	V9	6Q7 GT	860132
C10	100pF Ceramicon	666440	L10	H.T. R.F. Filter Choke "B" (Receiver)	790046	V10	12 v. Non-synchronous 4-Pin Vibrator	701104
C11	100pF Silvered Mica } Double	666440	L11	L.T. R.F. Filter Choke "A" (Receiver)	790047			
C12	100pF Silvered Mica } Double	666520	L12	L.T. R.F. Filter Choke "B" (Receiver)	790047			
C13	100pF Silvered Mica } Condenser	666520	L13	Master Oscillator Anode Choke	790047			
C14	532pF Swing Gang Condenser (Section 3)	800015*	L14	Power Amplifier Anode Choke	790047			
C15	3-30pF Philips Type Trimmer	800065	L15	Modulation Choke	780363			
C16	570pF Silvered Mica	666617	L16	R.F. Choke	790085			
C17	3-30pF Philips Type Trimmer	800065	L17	L.T. R.F. Filter Choke "C" (Receiver)	790046			
C18	3-30pF Philips Type Trimmer	800065	L18	L.T. R.F. Filter Choke "D" (Receiver)	790046			
C19	47pF Ceramicon N750K	666513	L19	Modulation Filter Choke	790086			
C20	2500pF Silvered Mica	666616						
C21	0.1μF Tubular Paper 350 v. wkg.	668076						
C22	100pF Silvered Mica } Double	668076						
C23	100pF Silvered Mica } Condenser	668076						
C24	0.1μF Tubular Paper 350 v. wkg.	668076						
C25	220pF Ceramicon	668076						
C26	0.1μF Tubular Paper	668076						
C27	100pF Ceramicon	668076						
C28	90μF Tubular Paper 500 v. wkg.	668076						
C29	80μF Electrolytic 200 v. wkg.	668076						
C30	80μF Electrolytic 200 v. wkg.	668076						
C31	0.01μF Tubular Paper 500 v. wkg.	668076						
C32	32μF Electrolytic 200 v. wkg.	668076						
C33	0.1μF Tubular Paper 350 v. wkg.	668076						
C34	0.1μF Tubular Paper 350 v. wkg.	668076						
C35	0.1μF Tubular Paper 350 v. wkg.	668076						
C36	50μF Electrolytic 12 v. wkg. A.C. wkg.	667104						
C37	0.1μF Tubular Paper 350 v. wkg.	668076						
C38	0.1μF Tubular Paper 350 v. wkg.	668076						
C39	12μF Electrolytic 25 v. wkg.	667103						
C40	25μF Electrolytic 25 v. wkg.	668053						
C41	0.1μF Tubular Paper 350 v. wkg.	668046						
C42	0.1μF Tubular Paper 1000 v. wkg.	666619						
C43	56pF Silvered Mica	666622						
C44	1000pF Silvered Mica	666622						
C45	470pF Silvered Mica	666622						
C46	1000pF Silvered Mica	666622						
C47	1000pF Silvered Mica	666622						
C48	1000pF Silvered Mica	666622						
C49	0.05μF Mica 500 v. wkg.	668080						
C50	0.05μF Mica 1500 v. wkg.	666126						
C51	532pF Swing Single Section Condenser	800013						
C52	0.1μF Visconal Type Condenser 2500 v. wkg.	668169						
C53	8μF Electrolytic 600 v. wkg.	667077						
C54	25μF Electrolytic 50 v. wkg.	667107						
C55	8-8μF Electrolytic 550 v. Surge, 450 p.k.	667106						
C56	0.1μF Tubular Paper 500 v. wkg.	668080						
C57	0.5μF Tubular Paper 350 v. wkg.	668061						
C58	47pF Silvered Mica	666621						
C59	1000pF Silvered Mica	666622						
C60	3-30pF Philips Type Trimmer	800065						
C61	0.1μF Tubular Paper 350 v. wkg.	668053						
C62	3-30pF Philips Type Trimmer	800065						
C63	47pF Ceramicon P120K	666460						
C64	1000pF Silvered Mica	666622						
C65	1000pF Silvered Mica	666622						
C66	1000pF Silvered Mica	666624						

Circuit Indication	RESISTORS	Ref. No.	Circuit Indication	TRANSFORMERS	Ref. No.
R1	1 M.Ω	670618			
R2	10 K.Ω	670618			
R3	1 M.Ω	670651			
R4	47 K.Ω	670635			
R5	22 K.Ω	670647			
R6	22 K.Ω	670635			
R7	22 K.Ω	670635			
R8	33 M.Ω	810032			
R9	1 M.Ω	810032			
R10	22 M.Ω	670635			
R11	470 K.Ω	670635			
R12	1 M.Ω	670618			
R13	82 Ω	670429			
R14	4700 Ω	670450			
R15	390 Ω	670513			
R16	2200 Ω	670644			
R17	100 K.Ω	670633			
R18	47 K.Ω	670402			
R19	270 K.Ω	670417			
R20	33 K.Ω	670815			
R21	47 K.Ω	670513			
R22	390 Ω	670802			
R23	15 K.Ω	671041			
R24	27 Ω	670513			
R25	390 Ω	671041			
R26	27 Ω	670816			
R27	20 K.Ω	670410			
R28	1 M.Ω	670695			
R29	39 Ω	670024			
R30	100 K.Ω	670362			
R31	22 K.Ω	670511			
R32	1 K.Ω	670511			
R33	270 Ω	670390			
R34	470 Ω	671079			
R35	30 K.Ω	671077			
R36	220 K.Ω	671077			
R37	220 K.Ω	670772			
R38	1.2 M.Ω	670508			
R39	47 K.Ω	670508			
R40	27 Ω	671041			

Circuit Indication	RELAYS	Ref. No.	Circuit Indication	PLUGS	Ref. No.
RL1/I	(g) Transmitter Rotary Transformer Relay	703001			
RL2/I	(g) Aerial Change-over Relay	703002			
RL3/2	(g) Receiver L.T. Relay Contacts	703000			
	(b) Transmitter H.T. Relay Contacts				

Circuit Indication	SWITCHES	Ref. No.
S1A	Aerial Coil Switch—Aerial	830237
S1B	Anode Coil Switch—Grid	
S2	Anode Coil Switch	
S3A	Oscillator Coil Switch—Grid	
S3B	Oscillator Coil Switch—Anode	
S4	Transmitter On/Off Switch	
S5	Main On/Off Switch	
S6	Netting Switch	
S7A	Channel Selector SW.—Crystal	830236
S7B	Channel Selector SW.—Aerial Coil Tapping	830239
S8	Metering Switch	

Circuit Indication	MISCELLANEOUS	Ref. No.
LP1	Receiver Dial Lamp	700500
LP2	Transmitter Indicator Lamp	700500
WP1	Full Wave Metal Rectifier	700810
M1	0-500μA Meter	700794
FI	250 mA Cartridge Fuse	700486

* 3 gang

