

Technical manual

9024

600 MHz

Frequency-period Meter

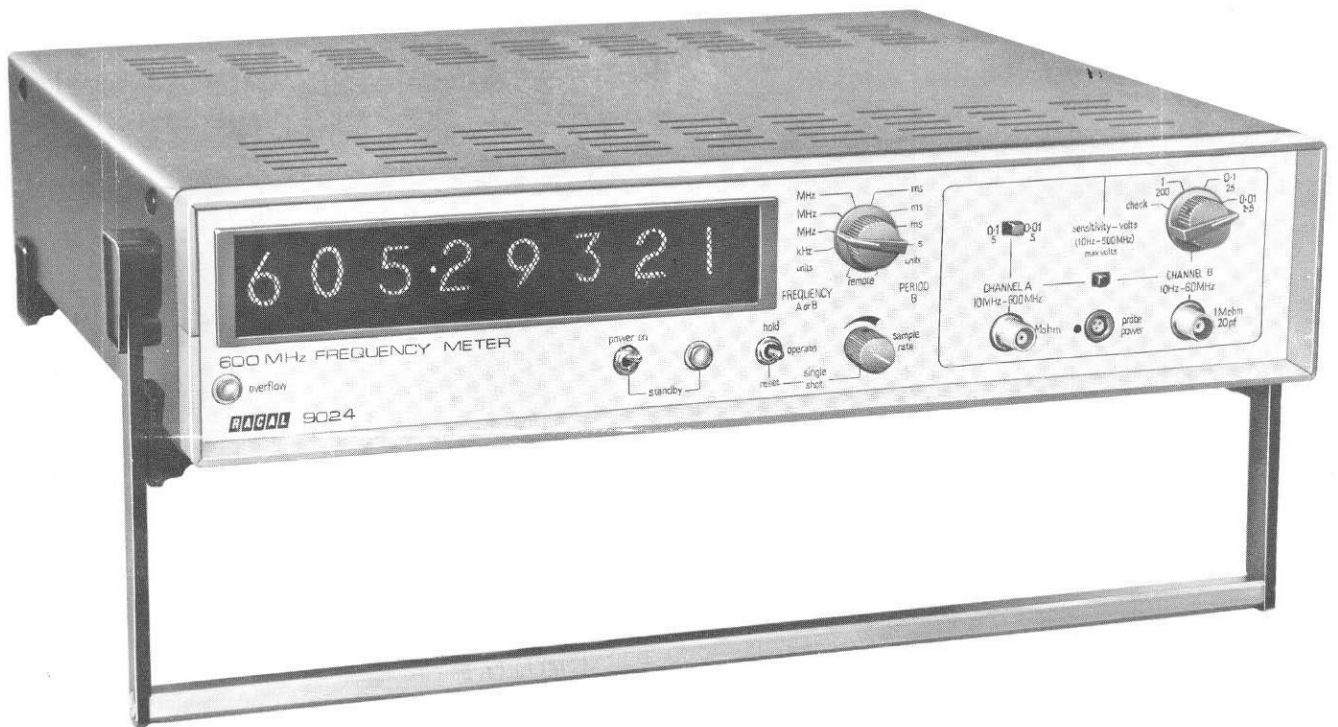

**Frequency-Period Meter
Type 9024**

CONTENTS

		<u>Page</u>
	FRONTISPIECE	
SECTION 1	TECHNICAL SPECIFICATION	
SECTION 2	DESCRIPTION OPERATION AND MAINTENANCE	
CHAPTER 1	GENERAL DESCRIPTION	1- 1
CHAPTER 2	PREPARATION FOR USE	
	Power and Earth Connections	2- 1
	Removal of case	2- 1
	Self-Check Procedure	2- 2
	Using an External Frequency Standard	2- 3
	Removal of Plug-in Boards	2- 3
	Fuselink Data	2- 3
CHAPTER 3	OPERATING	
	Description of Controls	
	OPERATING PROCEDURES	
	Frequency Measurement	
	Average Period Measurement	3- 4
	Operation with Active Probe	3- 5
	Connection of External Frequency Standard	3- 5
	1 MHz Output	3- 5
CHAPTER 4	PRINCIPLES OF OPERATION	
	Frequency Measurement	4- 1
	Period Measurement	4- 2
	Timebase and Control	4- 3
	Frequency Standard	4- 3
	Channel Selection	4- 3
CHAPTER 5	TECHNICAL DESCRIPTION	
	Attenuator and Pre-amplifier 11-0339	5- 1
	Attenuator 19-0620	5- 1
	Amplifier Divider Assembly 19-0630	5- 2
	Amplifier Gating Assembly 19-0379	5- 2
	Frequency Standard Oscillator Assembly	5- 3
	Timebase Divider Assembly 19-0352	5- 4
	Control Circuit Assembly 19-0356	5- 6
	Readout and Display	5- 8
	High Speed Decade Assembly 19-0460	5- 8
	Standard Readout Assembly	5-11
	Power Supply Assembly	5-14
	Power Switching	5-15

CONTENTS (Continued)

		<u>Page</u>
CHAPTER 6	MAINTENANCE	
	List of Test Equipment required	6-1
	Use of Test Equipment	6-1
	Power Supply Check	6-2
	Performance Tests and Setting-Up Procedures	6-4
	<u>ILLUSTRATIONS IN SECTION 2</u>	
<u>Fig. No.</u>		
2.1	Simplified Block Diagram	3-6
2.2	Frequency Measurement	4-1
2.3	Period Measurement	4-2
2.4	Control Circuit Waveforms	5-6
2.5	Timing Waveforms H.S. Decade 19-0460	5-10
2.6	Timing Waveforms: Standard Readout Decade	5-11
2.7	Service View: Chassis Upside	5-17
SECTION 3	PARTS LIST	
	Refer to the contents list at the beginning of the Parts List.	
SECTION 4	CIRCUIT DIAGRAMS AND LAYOUTS	
<u>Fig. No.</u>	<u>Title</u>	<u>Assembly Ref. No.</u>
4.1	Circuit: Pre-Amplifier Assembly	11-0339
4.2	Circuit: Oscillator Assembly	19-0636
4.3	Circuit: Power Supply Assembly	11-0565
4.4	Layout: Attenuator Assembly (Circuit Fig. 4.1)	19-0235
	Layout: Pre-Amplifier Assembly (Circuit Fig. 4.1) ..	19-0236
4.5	Layout: Timebase Divider Assembly	19-0352
4.6	Circuit: Timebase Divider Assembly	19-0352
4.7	Layout: Control Circuit Assembly	19-0356
4.8	Circuit: Control Circuit Assembly	19-0356
4.9	Layout: Amplifier Gating Assembly	19-0379
4.10	Circuit: Amplifier Gating Assembly	19-0379
4.11	Layout: Power Board (Circuit 4.3)	19-0433
4.12	Layout: Oscillator Board (Circuit 4.2)	19-0636
4.13	Layout: Standard Readout Assembly	19-0450
4.14	Circuit: Standard Readout Assembly	19-0450
4.15	Layout: High Speed Decade Assembly	19-0460
4.16	Circuit: High Speed Decade Assembly	19-0460
4.17	Layout: Attenuator)	19-0620
	Circuit: Attenuator)	

CONTENTS (Continued)

<u>Fig. No.</u>	<u>Title</u>	<u>Assembly Ref. No.</u>
4.18	Layout: Remote Control Assembly	19-0628
4.19	Circuit: Remote Control Assembly	19-0628
4.20	Layout: Amplifier Divider Assembly	19-0630
4.21	Circuit: Amplifier Divider Assembly	19-0630
4.22	Layout: Motherboard Assembly	
4.23	Circuit: Interconnections Type 9024	

SECTION 5 APPENDICES AND CHANGE INFORMATION

Appendix

- 1 Option 01: Data (BCD) Output.
- 2 Option 02: Remote Control & Data Output
- 3 Option 04: Alternative type of frequency standard
- 4 Option 06: Eight Digit Readout

TECHNICAL SPECIFICATION

1.1 FREQUENCY MEASUREMENT

Frequency Range:	10 Hz to 60 MHz (Direct Gating) Channel B 10 MHz to 600 MHz (Prescaling) Channel A
Accuracy:	± 1 count \pm time base accuracy
Gate Times:	10ms, 100ms, 1s and 10s.
Self Check:	Internal 1MHz signal fed through 'B' channel.

1.2 PERIOD MEASUREMENT

Range:	10Hz to 3MHz
Input Channel:	'B'
Periods Averaged:	1, 10, 100 or 1000.
Clock Units:	1 μ s.

1.3 RATIO MEASUREMENT

Display:	On Frequency Mode the Counter reads: $\frac{F \text{ (A or B channel)}}{F \text{ (Ext)}} \times M$ where M is 1 or 10 ³ On Period Mode the Counter reads: $\frac{F \text{ (Ext)}}{F \text{ (B Channel)}} \times \frac{1}{M}$ where M is 10 ³ or 10 ⁶
Range:	F (Ext) is any frequency between 1MHz and 15MHz.

1.4 INPUT 'A'

Frequency Range:	10MHz to 600MHz
Sensitivity:	Better than 10mV r.m.s. to 500MHz (typically better than 100mV at 600MHz).
Input Impedance:	50 ohms

Signal Range:

Position 1 (without attenuation)

10MHz to 500MHz : 10mV to 500mV.
500MHz to 600MHz : typically better than 100mV to 1V.

Position 2 (with 20dB attenuation)

10MHz to 500MHz : 100mV to 4V.
500MHz to 600MHz : typically better than 1V to 4V.

Damage Overload:

a. c. > 5V r.m.s.

d. c. The d. c. component plus peak input signal must not exceed 50V.

Input Connector:

50 ohm B.N.C. front panel.

1.5 INPUT 'B'

Frequency Range:

10Hz to 60MHz.

Sensitivity:

Better than 10mV r.m.s.
Better than 1mV r.m.s. using Active Probe 819 (option)

Input Impedance:

1M ohm in parallel with 20pF.
10M ohm using 10:1 passive probe.
1M ohm in parallel with 6pF using active probe Type Racal 819 (option).

Channel 'B'
Signal Conditions
(Volts r.m.s.)

Sensitivity Setting:	0.01	0.1	1.0
Signal Range (volts):	0.01-2.5	0.1-25	1.0-200
Damage Overload:	15V	150V	250V
DC plus peak A.C. Input:	Not to exceed 600V		

Input Connector:

B.N.C. front panel.

Self Check:

Internal 1MHz gated by Channel 'B' attenuator switch (CHECK position).

1.6 TIME BASE

Internal Frequency Standard

Oscillator Types:

Fast Warm Up Oscillator Unit:-
5MHz: Type 9400.

Warm-Up Accuracy:

4 minutes for 1 part in 10^7 .

Ageing Rate:

Better than 3 parts in 10^9 per day after one year.

Better than 1 part in 10^8 initially.

Temperature Performance:

Better than 7 parts in 10^9 per °C.

Optional Oscillator Type 9420

Ageing Rate:

Better than 1 part in 10^9 after one year.

Better than 5 parts in 10^9 initially.

Temperature Performance:

Better than 6 parts in 10^{10} per °C.

Internal Standard Output

Frequency:

1MHz Sinewave.

Level:

Nominally 1V r.m.s. from 50 ohms source.

Connector:

B.N.C. socket at rear of instrument.

External Standard Input

Frequency:

1MHz.

Minimum level 100mV r.m.s. into 1k ohm capacitively coupled.

Maximum level 10V r.m.s. 400V d.c.

Connector B.N.C. socket at rear of instrument.

External/Internal two position slide switch on rear panel for Standard Selection.

The external standard input may be used over the frequency range 1-15MHz, allowing a ratio measurement to be made.

See 1.3.

1.7 POWER INPUT

Voltage Range:

110V	(103V - 117V)
120V	(113V - 127V)
200V	(188V - 212V)
220V	(270V - 233V)
240V	(220V - 254V)

Frequency: 45 - 440Hz.
Connection: Three pin mains plug, rear panel.
Power Consumption: 60 VA approximately.

1.8 DISPLAY

Format: Seven digit, in-line, numerical indicator tubes plus overflow. Display latched-updated at completion of gate time.

Hold/Reset: Operation of the Hold/Reset toggle switch to up position retains the displayed information until released, when the instrument automatically resets to zero and is ready to commence a new measurement.

Sample Rate: The sample rate is determined by two factors:-

The length of the gate time and the turn around time. The turn around time may be varied from 250ms to 10s by means of the front panel Sample Rate control.

Single Shot: Single shot is achieved when the sample rate control is switched to 'single shot' and the Hold/Reset switch is depressed and then released.

1.9 PRINCIPAL MECHANICAL PARAMETERS

Physical

Height: case 3.3/8" (86 mm)
overall 4.1/16" (104mm) inc.ft.

Width: case 16" (407mm)
overall 17.1/8" (435mm)

Depth: case 14" (365mm)
overall 14.3/4" (375mm)

Weight: Approximately 19 lbs (8.62 Kg).

1.10 ENVIRONMENTAL CONDITIONS

The instrument conforms to the majority of D.E.F. 133 table L2 clauses within the following climatic limits:-

Storage temperature: -40°C to $+70^{\circ}\text{C}$

Operating temperature: 0°C to $+55^{\circ}\text{C}$

Humidity: 95% at 40°C .

1.11 ACCESSORIES PROVIDED

- (a) A six foot long, three core mains lead complete with mains socket.
- (b) A bag of spare fuses.
- (c) A handbook.
- (d) Two B.N.C. plugs.

1.12 OPTIONS

NOTE: All Logic Levels are TTL compatible.

Option 01

Display information format:

Data Outputs

4 line B.C.D. weighed

1.2.4.8. per display digit and 3 line decimal point position.

Function Information:

Function information format: 3 lines binary coded as follows:-

FUNCTION	CODE		
	X	Y	Z
Frequency	0	0	1
Period	0	1	1

Time base information:

3 lines binary coded as shown.

Format:

Gate Time	Code		
(frequency measurement)	x	y	z
10 sec.	0	1	1
1 sec.	1	0	1
0.1 sec.	0	0	1
0.01 sec.	1	1	0
<u>Periods Averaged</u>	<u>Code</u>		
	x	y	z
1000	0	0	1
100	1	1	0
10	0	1	0
1	1	0	0

Overflow:

Single line - indicated by '1' level.

Logic Level:

'1' state +2.4V to 4.5V } source impedance 180 ohm
'0' state 0V to 0.4V }

Command Output:

+2.4V to 4.5V } source impedance 180 ohm
off level 0 to 0.4V }

Hold/Reset: +2.4V to 10V (input impedance (1k ohm approx.
 off level -20V to 0.8V (input into a (reversed biased (diode

NOTE: Release of Hold/Reset will cause instrument to automatically reset and commence new measurement.

Print Hold: +2.4V to 10V (input impedance (1k ohm approx.
 off level -20V to 0.8V (input into (reversed biased (diode

Option 02

Remote Programme Operation - together with Data Outputs as contained in Option 01.

Remote Selection: By function switch on front panel.
 Function programme Format: XYZ control lines as shown under Option 01.
 '0' input for Frequency
 '1' input for Period Averaging.
 Channel Programme Format: Single control line operated as follows:
 '1' for A Channel,
 '0' for B Channel.
 Time Base Programme Format: 3 lines binary coded as shown.

<u>Gate Times</u> (frequency measurement)	<u>Code</u> x y z
10 sec.	0 1 1
1 sec.	1 0 1
0.1 sec.	0 0 1
0.01 sec.	1 1 0
<u>Periods Averaged</u>	<u>Code</u> x y z
1000	0 0 1
100	1 1 0
10	0 1 0
1	1 0 0

Logic Levels required: '1' state 2.4V to 10V into 1k ohm
'0' state -20V to 0.8V into reversed biased diode.

Print Hold: +2.4V to 10V
(input impedance 1k ohm approx.)
Off level -20V to 0.8V
(input into reversed biased diode).

Hold/Reset +2.4V to 10V
(input impedance 1k ohm approx.)
Off level -20V to +0.8V
(input into a reversed biased diode)

Remote Internal/External Standard Selection.

Single control line: '1' level external frequency standard.
(via REMOTE socket pin 9) '0' level internal frequency standard.

Logic levels required: '1' state 2.4V to 10V into 1k ohm.
'0' state -20V to 0.8V reverse biased diode.

Option 04 Alternative frequency standard Racal Type 9420. Refer to para. 1.6 of this Technical Specification.

Option 06 Eight digit readout.

1.13 OPTIONAL ACCESSORIES

- (a) A1. Active Probe: Type Racal 819, probe power derived from power socket adjacent to the input sockets, front panel.
- (b) A3. Rack mounting kit Racal Part No. 11-0609.
- (c) A5. Extension Board kit Racal Part No. 11-0600.

C H A P T E R 1

G E N E R A L D E S C R I P T I O N

INTRODUCTION

1.1 The Type 9024 is a compact, lightweight Frequency-Period Meter, styled in the Racal 9000 series image, being slim-line and of full rack width. It has a frequency measuring capability covering the range 10Hz to 600MHz. This is achieved using two input channels each with its own switched attenuator. Signals in the range 10MHz to 600MHz are applied to the Channel 'A' input where a Pre-Scaler Assembly of advanced design provides decade division. The Channel 'B' input is used when measuring frequency in the range 10Hz to 60 MHz, and also for Period Measurement in the range 10 Hz to 3 MHz.

CONTROLS

1.2 Separate Sensitivity Controls are provided for Channels 'A' and 'B', the sensitivity levels (in volts r.m.s.) at each setting being engraved in black and the maximum input levels in red. The slide switch at the centre of the input panel is the Channel Selector which should be set towards the particular input socket in use. The display time can be varied by the SAMPLE RATE control which, when turned to the extreme anti-clockwise position, operates a switch which provides a 'single shot' facility. The adjacent HOLD/OPERATE/RESET switch allows the display to be held at will, or, if briefly depressed to the RESET position, produces a new measurement, a facility which is useful when operating in the SINGLE SHOT mode or on long display time. The POWER switch has a STANDBY position which allows continuous operation of the frequency standard oscillator whilst the a.c. supply is connected.

CONNECTIONS

1.3 Input signals are applied via BNC front panel sockets. Both channels have an input sensitivity of 10mV r.m.s.; on Channel 'B' however, this can be increased to 1mV by use of the Racal Active Probe Type 819, for which a front panel power outlet is provided. Sockets are provided on the rear panel for external standard input and 1MHz reference output, the required facility being selected by an adjacent switch.

FREQUENCY STANDARD

1.4 The oscillator unit is one of the Racal "Fast-Warm-Up" range, which provides a high level of accuracy, and, by pre-ageing of the crystal before assembly, is assured of very stable characteristics. With mains supply connected the oscillator runs continuously, thus providing a sinusoidal 1MHz, reference frequency at the rear panel even though the instrument is otherwise not in use. An external frequency standard can be connected to the instrument; for normal measurement purposes this should be at 1MHz with an accuracy and stability not inferior to the internal oscillator, however, to provide a "ratio" facility the external standard input may be varied over the range 1 to 15MHz. Provision is made in the 9024 for remote selection of either internal or external frequency standard by means of logic signals applied to the Oscillator Assembly. A convenient connecting point for control signals is provided in the Remote Control socket when Option 02 is fitted.

READOUT

1.5 The seven digit, in-line, 'latched' display incorporating automatic decimal point positioning, enables the instrument to resolve measurements to 0.1Hz on the longest of the four available gate-times (10 ms, 100 ms, 1 s and 10 s) which are selected by the rotary function switch mounted on the front panel. Associated with the display is an Overflow Lamp which illuminates when the counter overflows, i.e. when the displayed reading is in excess of "all nines". At customer's option an additional readout assembly can be fitted to provide an 8-digit readout. (Option 06).

CONSTRUCTION

1.6 The case is constructed of duraluminium with ventilation slots in upper and lower surfaces. Four feet project from the rear face, thus permitting the instrument to be placed in the upright position with protection for panel-mounted components. The handle, which is pivoted at the sides of the case, moves through an arc of approximately 135° . In the vertical position it serves as a carrying handle, or can be set at 90° to the front panel for use as a bench stand.

1.7 Mechanical design is modular, almost all components being mounted on printed circuit boards (p.c.b.'s). Each assembly is identified by a six figure assembly number, and these numbers provide a convenient basis for the arrangement of parts lists and circuit diagrams in the handbook. An assembly identified by a number commencing with 11- (for example 11-0565) is a composite assembly consisting of one or more p.c.b.'s together with other items such as switches etc. not mounted on a board. An assembly which consists only of a single p.c.b. will have an assembly number commencing with 19- (e.g. 19-0379).

REMOTE CONTROL

1.8 Option 02 provides for remote programming of the 9024 using binary coding as detailed in the Technical Specification paragraph 1.12. The use of 3-line coding for the time base programme is a valuable design feature, used throughout the Racal 9000 series of counters, which allows any one instrument to slave (remotely control) another. Mechanical details of the available options are contained in an appendix at the rear of the handbook. It may be noted that when Option 02 is fitted it also includes the B.C.D. Data Output (Option 01).

CHAPTER 2

PREPARATION FOR USE

INTRODUCTION

2.1 To ensure correct use of the instrument the user is recommended to read the notes on front panel controls in Chapter 3 and the Brief Technical Description in Chapter 4 before setting to work.

POWER AND EARTH CONNECTIONS

- 2.2
- (1) Unpack the instrument and examine for any indication of physical damage. If it is desired to remove the case refer to paragraph 2.3 in this Chapter.
 - (2) Set the voltage adjuster on the rear panel to suit the mains supply voltage.
 - (3) Ensure that the Power Fuse on the rear panel is of the correct value for the mains supply voltage. (100/130V = 500 mA, 190/250V = 250 mA). The fuse must be of anti-surge type.
 - (4) Connect the instrument to the mains supply. The cable is colour coded as follows:-

Brown lead to line
Blue lead to neutral
Yellow/green lead to earth (ground)

- (5) With the instrument POWER switch to STANDBY switch on the mains a.c. supply and check that the amber "Standby" lamp illuminates.

REMOVAL OF CASE

- 2.3
- (1) Disconnect the power cable from the rear panel.
 - (2) Stand the instrument face downwards on the bench. Slacken off the four captive screws located in the plastic feet on the rear panel, using a large size "pozi-drive" screwdriver.
 - (3) Lift off the case.

FUSELINKS

2.4 Table of Fuselinks. Refer to page 2-3. Refer to Fig. 2.7 at the end of Chapter 6 for internal fuse location.

SELF-CHECK PROCEDURE

- 2.5 This check should be carried out when first using the instrument and periodically thereafter.
- (1) Check that the power supply connections are correct (para.2.2) and that the amber standby lamp is illuminated. Allow a 3 minute warm-up time.
 - (2) Set the instrument POWER switch to POWER ON, and note that the amber standby lamp extinguishes. The numerical indicator tubes in the display window should display digits.
 - (3) Put the HOLD/RESET switch to its centre position and turn the SAMPLE RATE knob fully clockwise.
 - (4) Set the CHANNEL 'B' SENSITIVITY switch to the CHECK position and the slide switch above the Probe Power socket to CHANNEL 'B'.
 - (5) Ensure that the EXT/INT switch on the rear panel is set to INT (down).
 - (6) Check the display against the Function switch positions in accordance with the following table, for 8-digit option see NOTE below.

TABLE 1

<u>FUNCTION/RANGE SWITCH</u>		<u>DISPLAY</u>	<u>REMARKS</u>
kHz	(10 seconds)	000.0000	→ Overflow lamp ON
MHz	(1 second)	1.000000	
MHz	(0.1 second)	01.00000	Tolerance on
MHz	(0.01 second)	001.0000	all readings
mS	(1000 Periods)	0.001000	± 1 count
mS	(100 Periods)	00.00100	
mS	(10 Periods)	000.0010	Check that decimal
S	(1 Period)	0.000001	point illumination is
REMOTE		0000000	correct at each setting.

NOTE: With 8-digit option (06) the 8th digit indicates '1' on the 10 second gate and the Overflow lamp does not illuminate.

- (7) Vary the SAMPLE RATE control and check that display time varies accordingly.
- (8) Check that the HOLD/RESET switch is functioning correctly. Press down and release and check that the instrument resets to zero and commences a new measurement. Press up and check that the display is retained while the Function switch is moved.

USING AN EXTERNAL FREQUENCY STANDARD (See also para 2.8 overleaf)

- 2.6
- (1) Put the EXT/INT switch on the rear panel to EXT.
 - (2) Connect the 1 MHz frequency standard (nominal level 1 Volt r.m.s.) to the coaxial socket on the rear panel.
 - (3) Operate the instrument as instructed in para. 2.5, allowing a suitable warm-up time for the external oscillator.

REMOVAL OF PLUG-IN BOARDS

2.7 A pair of Racal board extraction levers are provided with each instrument. These are designed to engage with holes in the printed circuit boards and, by a levering action, a board can be eased out of the edge connector. Take care to raise the board evenly to avoid pin distortion.

TABLE 2 - FUSELINK DATA

Circuit Reference	Function	Fuse Rating	Racal Part Number
FS1	+200V	60mA	23-0000
FS2	+12V	750mA	23-0005
FS3	+5V	1.5A	23-0007
FS4	+12V (crystal oven)	500mA	23-0004
FS5	-12V	500mA	23-0004
FS6	Mains Input (Rear Panel)	250mA (190-250V) or 500mA (100-130V)	23-0031 23-0022
NOTE: Mains fuse must be anti-surge type			

REMOTE PROGRAMMING OF FREQUENCY STANDARD

2.8 A connection to the Frequency Standard EXT/INT switch permits remote selection of either internal or external oscillator. The necessary data is contained in the Technical Specification page (9) and a description is given in Chapter 5 para 5.17. When Option 02 is fitted the appropriate control connection is via pin 9 of the REMOTE socket. Note that for remote control the EXT/INT switch must be set to INT.

CHAPTER 3

OPERATING

DESCRIPTION OF CONTROLS

3.1

POWER ON and STANDBY Switch:

A toggle switch, which in the 'up' position completes the +220V and +12V d.c. outputs from the power unit to the Motherboard. It should be noted that the a.c. supply is not switched, therefore dangerous voltages are present in the instrument so long as it is connected to an a.c. supply. In the STANDBY position of the switch the +12V remains connected to the frequency standard oscillator assembly as indicated by illumination of the STANDBY lamp.

Input Channel Selector Switch:

Two position slide switch which selects Channel A or Channel B input.

Function Switch:

This is a rotary switch which selects 'gate time' for frequency measurement and "number of periods averaged" for period measurement. Against each setting is engraved the units in which the display should be read.

The REMOTE position of the switch enables the 'gate time' and 'periods averaged' functions to be programmed from a remote station, with remote indication of readout.

SENSITIVITY Switches:

Also referred to as the Attenuator Switches, Channel A (10 MHz - 600 MHz) control selects two levels of attenuation giving input sensitivities of 0.1V and 0.01V r.m.s. for frequencies up to 500 MHz, for frequencies above 500 MHz the input sensitivities are 1V and 0.1V r.m.s. Channel B (10 Hz - 60 MHz) control selects three levels of attenuation giving input sensitivities of 1V, 0.1V and 0.01V r.m.s.

The red figures indicate the absolute maximum signal levels (r.m.s.) which may be fed into the instrument at each level of sensitivity.

In the CHECK position the external signal input is disconnected and the 1 MHz signal from the frequency standard is fed through the counting stages to provide a self-check facility.

SAMPLE RATE Control:

A combined potentiometer and switch. Turned clockwise it reduces the duration of the display time and gives an increased sampling rate. Turned fully anti-clockwise until the switch operates, it then holds the display and prevents further updating except by use of the RESET position of the HOLD/RESET switch.

HOLD/RESET Switch:

A three-position toggle switch. The central position is the normal operating mode. By depressing the switch, "Reset" will occur allowing a new measurement to be made and displayed. This is useful when operating on Single Shot or on long display time. The upper (HOLD) position enables the operator to 'hold' the display at any time without having to select Single Shot.

Display Controls

3.2 The following notes will summarize the relationship between the various controls affecting the display. The rate at which measurement samples are taken is determined by:-

- (a) The duration of the gating period.
- (b) The turn round time which may be varied between 10 seconds and 250 milliseconds by turning the SAMPLE RATE control in a clockwise direction.

Automatic updating of the display will cease when the SAMPLE RATE knob is turned fully anti-clockwise and clicked into the SINGLE SHOT position, a condition under which a new reading may be obtained by momentarily depressing and then releasing the HOLD/RESET switch. If put to the 'up' position the HOLD/RESET switch will hold the digits in the display irrespective of other controls, but it should be noted that if the FUNCTION/RANGE switch setting is altered, the decimal point will move. In all circumstances other than 'Hold' whenever the FUNCTION/RANGE switch setting is altered the instrument will 'clear-down', re-sample, and display a new reading.

Rear Panel Items

3.3 On the rear panel are mounted the mains power plug, mains fuse and voltage selector. Provision is made for fitting the optional Data and Remote Programming outlets. A slide switch marked EXT/INT permits selection of frequency standard input or output. In the EXT position an external 1 MHz standard may be connected to the adjacent EXT FREQ. INPUT socket, the internal oscillator being disconnected. In the INT position a near sinusoidal 1 MHz output derived from the internal standard is available at the adjacent 1 MHz OUTPUT socket.

OPERATING PROCEDURES

INTRODUCTION

3.4 Refer to Chapter 2 and check that the Power connections have been correctly made. Carry out the Self-Check Procedure to be assured of satisfactory performance. (Para. 2.5).

FREQUENCY MEASUREMENT

- 3.5 (1) Allow not less than 3 minutes warm-up time on STANDBY.
- (2) Switch to POWER ON. Note that the Standby lamp extinguishes and that displayed digits appear in the readout.
- (3) Set the SAMPLE RATE and HOLD/RESET controls as required.
- (4) Set the SENSITIVITY - VOLTS switch to 0.1 for Channel A (10 MHz - 600 MHz) input or 1 for Channel B (10 Hz - 60 MHz) input.
- (5) Connect the signal to be measured to the appropriate Channel A or Channel B socket.
- (6) Set the Input Channel Selector slide switch to the required 'A' or 'B' position.
- (7) Set the FUNCTION switch to the required Gate-Time. (See (9) below).
- (8) The frequency of the input signal should now be displayed on the readout. If a satisfactory display is not obtained on Channel A input re-check the display with SENSITIVITY at 0.01. If a

satisfactory display is not obtained on Channel 'B' input re-check the display with SENSITIVITY at 0.1 and once again, if necessary, at 0.01. If a satisfactory display is still not obtained, check that the level of the input signal is not lower than 10 mV r.m.s.

- (9) When using gate times of long duration the count may overflow (OVERFLOW lamp illuminates). Take a reading using a shorter gate time to determine the most significant digits, and then use the longer gate times to obtain a high resolution.
- (10) To hold the display, set the HOLD/RESET to HOLD.

NOTE: Below 10 kHz, greater accuracy may be obtained by measuring the average period over a number of cycles and calculating frequency.

AVERAGE PERIOD MEASUREMENT

- 3.6 This mode is recommended for measuring low frequencies in the range below 10 kHz and for short repetitive time intervals.
- 3.7 The incoming unknown signal is taken to the time-base decade dividers, the output from which, selected by the PERIOD position of the Function switch, is used to gate the internal frequency standard to the counter decades.
 - (1) Select the number of periods to be measured by setting the Function switch to :- 1, 10, 100 or 1000.
 - (2) Set the Channel Selector slide switch to CHANNEL 'B'.
 - (3) Connect the unknown signal to the CHANNEL 'B' input socket.
 - (4) Set the SAMPLE RATE control to give a suitable display time.
 - (5) When averaging over a large number of cycles to obtain higher resolution, the count may overflow the display in which case a second reading averaged over fewer cycles to determine the most significant digits should be taken.

NOTE:1: The display indicates the actual value of the period of the incoming signal. Note the unit (μ s or ms) which corresponds to the position selected on the Function switch.

NOTE:2: At lower frequencies, the trigger error becomes significant. Its effect can be minimised by averaging over many cycles with overflow, and reducing the result to six significant digits.

OPERATION WITH ACTIVE PROBE (CHANNEL B)

3.8 By using the Racal Active Probe Type 819, the sensitivity of the instrument is improved to 1 mV r.m.s. on Channel B.

- (1) Connect the power supply lead of the 819 Probe to the 3-pin outlet marked PROBE POWER on the front panel of the 9024.
- (2) Connect the signal output lead of the 819 Probe to the CHANNEL B input socket of the 9024.

NOTE: A separate handbook is available for the 819 Probe.

CONNECTION OF EXTERNAL FREQUENCY STANDARD

3.9 On the rear panel set the EXT/INT switch to EXT, and connect the 1 MHz source (not lower than 0.1V into 1k Ω) to the socket EXT FREQ. INPUT. It should be borne in mind that the accuracy of the frequency standard will have a direct effect on the precision of measurement made by the counter. The instrument will accept an external frequency standard in the range 1 to 15 MHz, thus providing a ratio measurement facility.

1 MHz OUTPUT

3.10 The internal 1 MHz reference frequency is available as a nearly sinusoidal output at the rear panel socket ' 1MHz OUTPUT '. The adjacent switch must be set to INT.

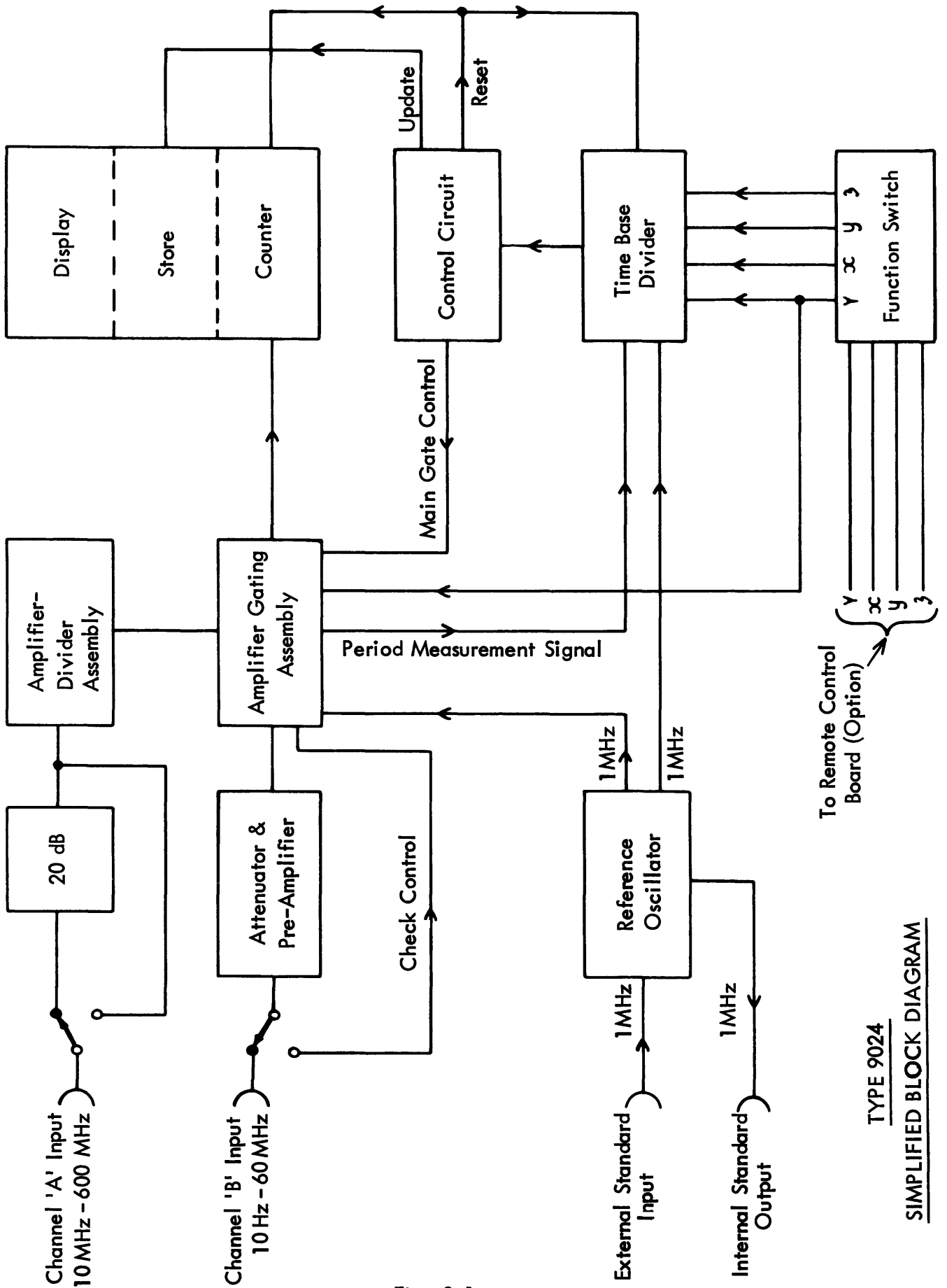

Fig. 2.1

TYPE 9024
SIMPLIFIED BLOCK DIAGRAM

CHAPTER 4

PRINCIPLES OF OPERATION

FREQUENCY MEASUREMENT

Fig. 2.2

4.1 The instrument measures frequency by counting the cycles of an input signal for an accurately known period of time. Two signal inputs are available, signals from 10 MHz to 600 MHz are applied via input socket 'A' to the Amplifier Divider Assembly (19-0630), 20 dB attenuation may be switched in if required and is provided by Attenuator (11-0620). Signals from 10 Hz to 60 MHz are applied via input socket 'B' and the rotary sensitivity switch to the Attenuator and Pre-Amplifier (11-0339). When the main signal gate in the Amplifier Gating Assembly (19-0379) is opened by a 'Gate Time' signal from the Timebase (19-0352) the unknown signal is released to the counting decades for a precise time interval determined by the Gate Time setting of the Function switch. At the end of the gating period the count is stopped and the total is transferred via the Readout stages (19-0450) to the numerical display lamps. The total is displayed on the indicator lamps for a time interval determined by the setting of the SAMPLE RATE control. Then, unless HOLD or SINGLE SHOT has been selected, the counter will reset, clear the display to "all zero's" and repeat the cycle of operations. All timing processes are referenced to the very stable 1 MHz signal derived from the Frequency Standard oscillator.

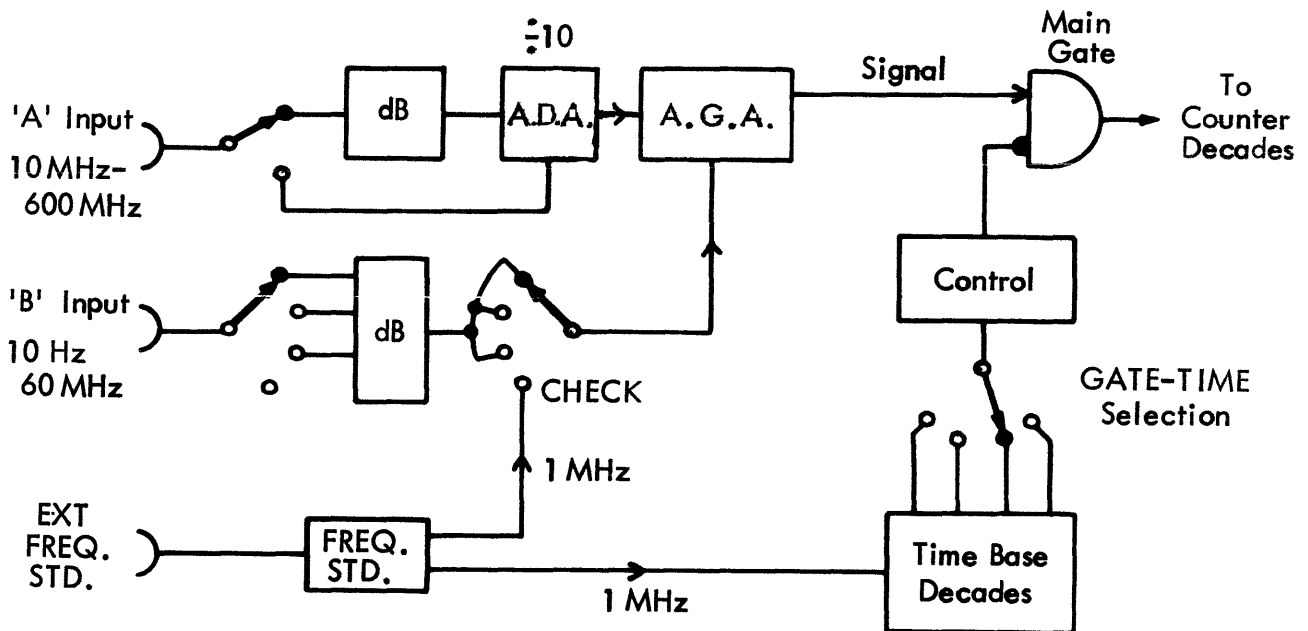

Frequency Measurement

Fig. 2.2

SELF-CHECK

4.2 In the CHECK mode the instrument operates as for frequency or period measurement except that the 1 MHz signal from the Frequency Standard takes the place of an unknown signal at the input to the A.G.A. Thus a readout of 1.000000 ± 1 count confirms that the instrument measuring circuits are serviceable.

PERIOD MEASUREMENT

Fig. 2.3

4.3 In the Period mode the unknown signal is used to control the gating time and the clock pulses from the frequency standard are counted during one or more cycles of the unknown signal. Greater accuracy is obtained by measuring over as many cycles as possible. The readout displays the clock pulses counted during an average period and the units of the display are as engraved against the selected position of the Function switch.

4.4 Referring to Fig. 2.3 below, it is seen that the signal of unknown frequency from input socket 'B' is shaped and applied to the Timebase decades. In the Timebase the unknown signal generates a selection of gate waveforms, one of which is selected by a PERIOD position of the Function switch. The chosen gating waveform is applied to the main gate to control the number of cycles during which the measurement is taken.

4.5 Clock pulses from the Frequency Standard are fed to the signal input of the main gate and are counted in the counting decades during the time interval controlled by the selected timebase output. The displayed readout is the average period of the unknown signal which can be converted to frequency by a simple calculation.

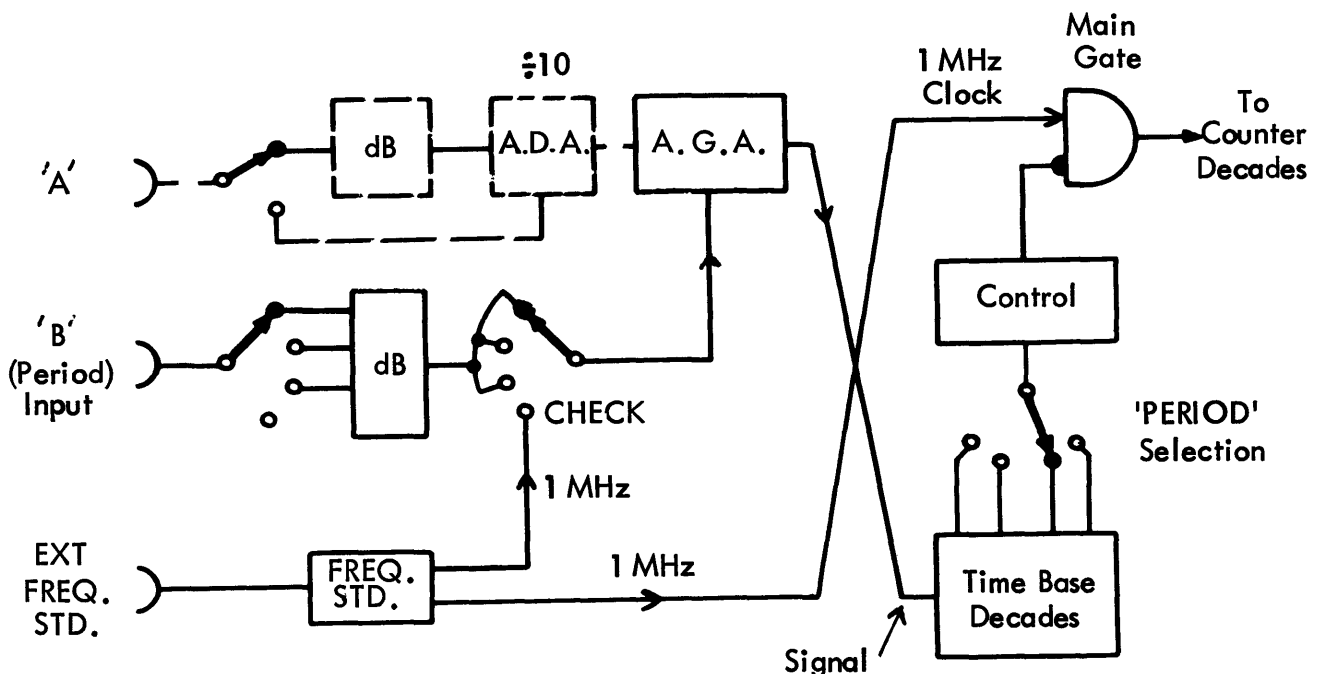

Period Measurement: Channel 'B'

Fig. 2.3

TIMEBASE and CONTROL

4.6 The Timebase Divider consists of a number of integrated circuit decades which divide down the applied input to the board to produce the timing signals necessary for the various functions and ranges of the instrument. Selection of the required output from this board is achieved by a combination of gates which are primed by the binary coded output from the Function switch. Signals from the Timebase Divider govern the Control Circuit which in turn opens and closes the Main Gate, and produces the Reset and Update command signals.

FREQUENCY STANDARD

4.7 A Racal Fast warm up oscillator of either 5 MHz or 10 MHz type may be fitted. The oscillator output being divided down to 1 MHz in the oscillator p.c.b. assembly and this reference frequency determines the accuracy of all timing process within the instrument. The oscillator is a plug-in unit and bearing in mind that the accuracy and resolution of the instrument is directly related to the accuracy of the frequency standard, it is recommended that a replacement unit be fitted if a fault occurs. Link facilities in the p.c.b. assembly enable either a 5 MHz or 10 MHz oscillator to be used as a direct replacement. The connections to the oscillator unit are very accessible and a simple test procedure is given in the Maintenance instructions. Servicing of the oscillator should be carried out by Racal Instruments Ltd., or by an authorized repair agency.

CHANNEL SELECTION

4.8 Since both Channel A and Channel B inputs are fed to a common stage in the Amplifier Gating Assembly, it is necessary to disable the amplifier which is not in use. This is the function of the Channel Selector switch S5 (see Fig. 4.23) which connects the +12V supply to the appropriate A or B amplifier assembly (either 19-0630 or 11-0339).

4.9 When the Remote Control Option is fitted certain links are removed and the relay RLA (Fig. 4.23) performs the channel selection function. The relay coil being energized from +12V within the instrument via pin 19 of the Remote Control Assembly (19-0628) and pin 7 of the Remote Control socket where the application of a logical '1' selects Channel A and a '0' selects Channel B.

CHAPTER 5

TECHNICAL DESCRIPTION

ATTENUATOR AND PRE-AMPLIFIER 11-0339 (CHANNEL B)

Fig. 4.1

- 5.1 The Attenuator and Pre-Amplifier Assembly is contained within a screening box and mounted behind the B Channel SENSITIVITY switch on the front panel. The circuit is shown in Fig. 4.1 and will be seen to consist of two separate printed circuit boards, 19-0235 and 19-0236, together with the switch.
- 5.2 The Attenuator Assembly 19-0235 is shown within the chained line on the left of the diagram and consists basically of a resistor potential divider network. The resistors alone determine the attenuation at low frequencies, but correct attenuation at high frequencies is achieved by the adjustment of the trimmers C3 and C5. The outputs from contacts 2, 3 and 4 of the printed circuit board represent 0 dB, -20dB and -40 dB respectively.
- 5.3 The chained line to the right of the diagram encloses the circuit of the Pre-Amplifier Assembly 19-0236. The signal level selected by the SENSITIVITY switch S1b is a.c. coupled via C9 to the gate of the field effect transistor Q1, the bias for which is obtained from the 6.8V zener diode D3. Across the input circuit the limiting arrangement of D1, Q6, D2 and Q7, clips both positive and negative excursions of the applied signal. The transistor Q2 acts as the constant current source for the FET, whilst the transistor Q3 may be looked upon as a shunt feedback amplifier. This whole input configuration provides a well defined gain coupled with a low input capacitance and high input resistance.
- 5.4 Signals developed across R9 are a.c. coupled via C12, C24 to the base of Q4, the first transistor in the long-tailed pair formed by Q4 and Q5. Further clipping action from D5, D6 improves the shape of the signal presented to Q4. The signal developed across R20 is applied via the zener diode D7 to the first stage of the Amplifier Gating Assembly. The +12V supply to the amplifier board is supplied via the Channel Selector switch on the front panel of the instrument.

ATTENUATOR 19-0620 (CHANNEL A)

Fig. 4.17

- 5.5 Input signals in the frequency range 10 MHz to 600 MHz are fed via input socket 'A'. The slide switch offers a choice of a direct signal path to the Amplifier Divider Assembly, or 20 dB attenuation by a conventional attenuator network.

Input Amplifier

5.6 The signal from the Channel 'A' Attenuator Assembly enters the Amplifier Divider Assembly at SKT1, with an input impedance of 50Ω and is applied to the amplifier formed by transistors Q1, Q2, Q3 and Q4, which has a nominal overall voltage gain of 14. Adjustment is provided at C3 and C8 for high-frequency compensation to ensure adequate gain over the entire frequency range of the instrument.

Shaping

5.7 From the amplifier output at Q4 signals are fed to the shaper circuit consisting of transistor Q6 and tunnel diode D2. When fitting a new tunnel diode to the p.c.b. it is vital that the correct soldering procedure is followed (see Chapter 6, para 6.25). The bias on Q6 is set by transistor Q5 with preset adjustment by R24. The signal across D2 is fed to Q7, and after further amplification, into the divide-by-ten integrated circuit package IC1. The divided output is amplified by Q8 and applied to Q9 and Q10. The output from emitter follower Q9 is taken to the Amplifier Gating Assembly 19-0379. An additional output from emitter follower Q10 is available but is not used in this instrument. The +12V supply to the assembly is supplied via the Channel Selector switch on the front panel of the instrument.

AMPLIFIER GATING ASSEMBLY 19-0379 (A.G.A.)

5.8 Signals from the 'B' Channel Attenuator and Pre-Amplifier enter the A.G.A. via pin 7 whilst signals from the Amplifier Divider Assembly (Channel A) enter via pin 23.

5.9 The first four transistors in this circuit comprise a two-stage amplifier. The emitter follower Q1 offers a high input impedance to the applied signal and acts as a buffer between the input and the first voltage amplifier Q2. Low frequency decoupling from the emitter of Q2 is by C13, whilst high frequency peaking is by adjustment of C11. The diodes D4 and D5 limit the input to the base of Q3. Emitter followers Q5 and Q8 act as buffer stages on either side of the Schmitt Trigger formed by Q6, Q7; R25 effectively adjusts the bias to provide a sensitivity control for the trigger, while D11 compensates for effects of temperature on the bias point. The zener D9 provides fast switching within the Schmitt circuit and bead X4 in the emitter of Q8 damps the overshoot. The resultant output is differentiated by C26, and the pulse train leaving the collector of Q9 is now offered two alternative paths, as it is applied to both the base of Q10 and the base of Q12.

Frequency measurement

5.10 When the Function switch is turned to any one of the four FREQUENCY positions the Y input goes to a '0' level, and reaches the base of Q11 via pin 16 of the printed circuit board, Q11 is turned off permitting the output from Q10 to reach the base

of Q14. At the same time the '0' level entering pin 16 is inverted by the transistor Q19, the resultant '1' level being applied to the bases of Q13 and Q17 respectively, clamping the outputs from Q12 and Q18.

5.11 The main gate on this assembly is formed by the transistors Q14, Q15, and Q16.

The gate is opened by a '0' level from the Control Circuit Assembly which enters the circuit on pin 12 and is applied to the base of Q16. Under these conditions the output pulses from the emitter follower Q20 are fed directly to the counter. When a '1' state is received from the Control Circuit Q16 will turn on, the collector of Q14 is clamped to 0V which closes the gate and cuts off the signal flow to the counter.

Period Measurement

5.12 When the Function switch is turned to any one of the four PERIOD positions, pin 16 will receive a '1' level, turning on Q11 and Q19. The output from Q10 is now clamped to 0V, which diverts the incoming signal through Q12 and out via pin 15 to the Timebase Divider. The '1' state inverted by Q19 not only turns off Q13 (to enable Q12) but also turns off Q17, removing the clamp from Q18. This allows the 1 μ s clock pulses from pin 17 to reach the base of Q15. From here they will pass into the counter via Q20 in accordance with '0' and '1' states applied to the base of Q16 by the Control Circuit.

5.13 The '1' level now on pin 16 for period measurement is applied to the base of a third transistor Q21, having the effect of bringing C29 into circuit, which reduces the upper limit of the amplifier's bandwidth to 3MHz.

Check Signal

5.14 With the rotary SENSITIVITY switch set to any of the three Sensitivity positions and with "Channel B" selected, pin 3 on the A.G.A. is open circuit, which results in a reverse bias being applied to diode D1. Turned to the CHECK position the input signal is disconnected from pin 7 (S1B Fig. 4.1) and pin 3 is taken to -12V (S1Ba Fig. 4.1). In this condition the 1MHz signal from pin 17 is applied via R54, C2 and the now conducting D1 to the collector of Q2 and used as a check signal. The 1MHz square wave from pin 17 is attenuated and shaped by R54 and C2 in conjunction with C3. The decoupling from R1 and C32 prevents the 1MHz signal from passing into the Attenuator and Pre-Amplifier Assembly.

FREQUENCY STANDARD OSCILLATOR ASSEMBLY

Fig. 4.2

Introduction

5.15 The Oscillator Assembly consists of p.c.b. 19-0636 together with a fast-warm-up oscillator unit. The EXT/INT switch mounted on the rear panel permits selection of either internal or external frequency standard source. In earlier models the oscillator unit was mounted on an Assembly with the p.c.b., but in later versions the oscillator is attached to the inner face of the rear panel with adjustment access via a hole in the panel. In the event of an oscillator fault it is recommended that the unit be returned to Racal Instruments Ltd., or authorised agent.

External/Internal Standards

5.16 Sockets on the rear panel make provision for a 1MHz reference output derived from the frequency standard and also for the connection of an external 1MHz reference source. Operation from internal or external standard source may be chosen by manual setting of the EXT/INT switch, or by remote programming.

Remote Programming

5.17 With the EXT/INT switch set to INT the frequency standard source may be programmed by logic levels applied to pin 9 of the rear panel REMOTE socket, as follows:-

Logic '1' will select 'external' standard source.

Logic '0' will select 'internal' standard source.

Logic levels required are:-

'1' state +2.4V to +10V into 1k Ω

'0' state -20V to +0.8V reverse biased diode.

Internal Standard Operation (refer to Fig 4.2)

5.18 The internal oscillator output is fed via the shaper circuit to Q3 and pulse amplifier Q5 to the decade divider IC1 which is wired in a $\frac{1}{5}$, $\div 10$ configuration. The divided output must be 1MHz, thus with a 5MHz oscillator the link LK1 will be connected to select the $\frac{1}{5}$ output.

5.19 Gating. With switch SW1 at INT, Q6 will be turned off, the resulting '1' at IC2a pins 1 & 2 producing a '0' at IC2d/12. Due to the '0' on IC2d/12, logic '1' is applied to IC2c/10 which opens the gate IC2c. As IC2b is already open due to the '1' on IC2b/4 the internal 1MHz signal from IC1 can pass to the output at pin 10 on the p. c. b.

5.20 The external 1MHz reference is applied via the rear panel IN socket to the shaper Q1 and pulse amplifier Q4. With switch SW1 at EXT, Q6 is turned on by +12V, the resulting logic '1' at IC2a/3 opens the gate IC2d. Since IC2c/9 is also at '1' the external signal can pass through IC2c to the output. At the same time IC2b remains closed due to the logic '0' from Q6 collector, thus inhibiting the 1MHz internal signal from IC1. The gating sequence just described can also be achieved under remote program control (para 5.17).

5.21 The output from the decade divider IC1 is also taken to the base Q2, in which the collector circuit, formed by the primary of T1 with C5, produces a sinewave of 1MHz available for external use from the OUT socket on the rear panel. The optimum waveform shape will result from a 1:1 mark-space ratio of the square wave leaving the decade divider IC1.

5.22 The potential divider R31/R32 and the two transistors Q7 and Q8 with associated circuitry provide a constant +5 volts from the +12V source, thus ensuring operation during Standby.

TIMEBASE DIVIDER ASSEMBLY 19-0352

Fig. 4.6

5.23 This is a standard assembly and some of the components are not used by the 9024 but their logic output levels must be such that they prime the gates which are required. Thus in the diagram shown in Fig. 4.6 unused components appear in dashed outline; but pin 17 is taken to 0V, which results in '1' level outputs from the three unwanted gates IC1d, IC6a and IC6b.

5.24 Paragraph 5.10 describes how the Y output from the Function switch determines whether the instrument is set for a frequency or period measurement. For a frequency measurement the Y level is '0', which applied to pin 7 of the Time Base Divider Assembly, will inhibit the gate IC5a which puts a logic '1' on pin 13 of IC5b: pins 9 and 10 of this gate are already at a '1' level from the unused gates IC6a and IC6b. The gate IC6c is opened by the logic '1' from the unused gate IC1d and the $\bar{Y} = 1$ from the collector of Q1. The 1MHz output from the oscillator follows a path via pins 17 and 14 of the Amplifier Gating Assembly 19-0379, and enters the Time Base Divider Assembly 19-0352 on pin 3. The decade elements IC7 and IC8 divide the frequency to 10kHz which then passes through the now open gates IC6c and IC5b to enter the time base divider chain formed by IC's 9 to 13.

5.25 When the Function switch is set to one of the four Period settings its Y output becomes a '1' level and applied to pin 4 of IC5a, in conjunction with the '1' already on pin 2, will open this gate. The $\bar{Y} = 0$ from Q1 will inhibit IC6c blocking the 10kHz output from IC8, and the '1' level output from IC6c will open IC5b. Signals leaving the Amplifier Gating Assembly (19-0379) by pin 15 (see paragraph 5.12) enter the Time Base assembly by pin 8 and pass through gates IC5a and IC5b into the time base divider chain.

5.26 Selection of the required output from the time base divider chain is achieved by a three-line binary code set up by the Function switch and identified as the x, y, z levels. The codes for all eight ranges of the instrument are given in Table 3 below:-

TABLE 3

<u>Function</u>	<u>Time Base Output</u>	<u>Code x</u>	<u>y</u>	<u>z</u>
Frequency Measurement	10s	0	1	1
Frequency Measurement	1s	1	0	1
Frequency Measurement	0.1s	0	0	1
Frequency Measurement	0.01s	1	1	0
Periods Averaged	1000	0	0	1
Periods Averaged	100	1	1	0
Periods Averaged	10	0	1	0
Periods Averaged	1	1	0	0

For example, assume that the Function switch has been set to a gate time of 0.01 seconds or to 100 periods. In either of these positions the output from the time base divider chain is from the same point, pin 11 of IC10, therefore the same x, y, z code, 1, 1, 0, appears for each in Table 3 above.

5.27 With contacts 19, 20 and 18 coded 1, 1, 0 and the inversions of 0, 0, 1 from the three gates of IC1 which are in use, if the circuit is traced out it will be seen that only two gates remain open, IC3a and IC4. Thus, only the output from IC10 is provided with a path to pin 9 for application to the Control Circuit.

THE CONTROL CIRCUIT ASSEMBLY 19-0356

Fig. 4.8

5.28 Throughout the following explanation reference should be made to Fig. 4.8 at the rear of the book, certain areas of which, not applicable to the 9024, appear in dashed outline only.

5.29 The main gate control bistable formed by Q3 and Q4 is a high speed circuit similar to that used in the High Speed Decade (Fig. 4.16) and is designed to ensure a fast, clean control of the gating period. When the gate is closed Q4 is in the "on" condition. An edge from the time base divider, via pin 3, will cause the bistable to change state, thus turning Q4 off. The high level at the collector of Q4 turns on Q2 and the '0' level at the collector of Q2 is buffered by Q18 which shifts the level and improves the line driving.

5.30 The next signal from the time base divider which marks the end of the gating period will toggle the bistable again, turning on Q4 and thereby closing the main gate. This gate coincides with Q3 going "off" to produce a positive-going edge at its collector which will toggle IC1a to produce outputs of $Q = 1$, $\bar{Q} = 0$. The Q output will turn on Q6 which switches off Q5 to clamp the main gate control bistable in the 'gate closed' state.

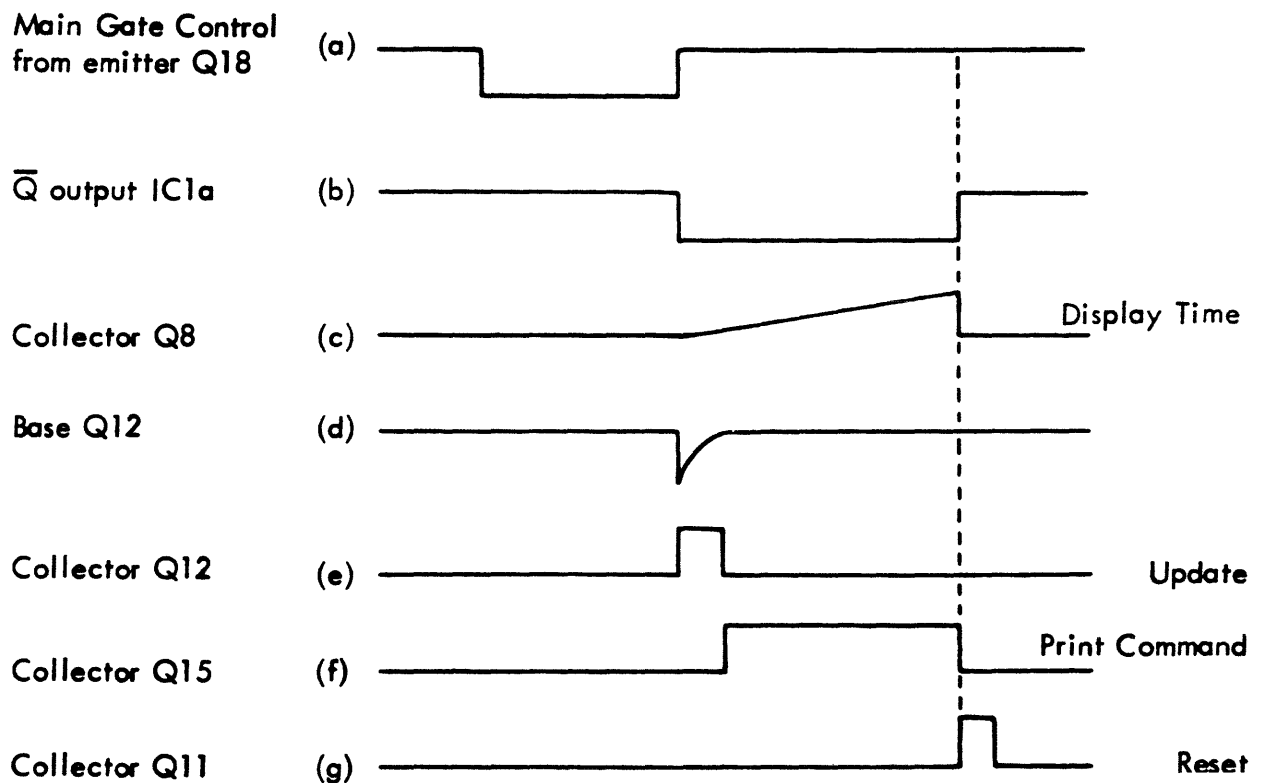

Fig. 2.4. - Control Circuit Waveforms

5.31 The \bar{Q} output of IC1a now at '0' will turn off Q8 which permits the Sample Rate Generator to commence charging (waveform (c) in Fig. 2.4). At the same time the negative-going edge from \bar{Q} is differentiated to switch off Q12 momentarily and produce the 'update' pulse at Q12 collector; this pulse is fed via pin 17 to the latch input on IC2 of each Readout board. During the high level period of the update pulse, current will flow through D8 into the base of Q15 keeping this transistor "on"; but when the update pulse reverts to '0' the base of Q15 is maintained at a '0' level by the \bar{Q} output of IC1a. Q15 will turn off and the positive edge at its collector indicates the start of the 'print-out' period (waveform (f) in Fig. 2.4).

5.32 The charging rate of the time display generator which can be varied from 250 milliseconds to 10 seconds, approximately, is determined by the setting of the SAMPLE RATE control on the front panel. Dependent on the setting of the SAMPLE RATE control the charge on C6 will eventually be large enough to cause Q9 and Q10 to conduct, and when they do so C6 discharges very rapidly and during the discharge time Q11 is turned "off" to produce the reset pulse at its collector.

5.33 The positive-going edge of the reset pulse is inverted by Q7 which immediately clears the bistable IC1a sending its output to $Q = 0$, $\bar{Q} = 1$. Prior to this action, Q6 was being held on by the high level Q output of IC1a; now, with this IC cleared, Q6 is still held on by the high level of the reset pulse through D16. This maintains the clamp on the gate control bistable until the reset action throughout the instrument has been completed. The \bar{Q} output of IC1a now at a '1' level turns on Q8 and Q15; this causes Q8 to complete the discharge of C6 and thereby terminates the reset pulse, and Q15 terminates the print command pulse.

External Hold

5.34 If, after the print command output has been initiated when the collector of Q15 goes high, the external equipment deems it necessary to impose a 'hold' condition on the sample rate, it will do so by sending a logic '1' into the instrument which, via pin 14, will turn on Q19 and thus prevent C6 from charging.

Hold and Single Shot

5.35 To hold a given display for an indefinite time the three-position toggle switch on the front panel will be moved to the 'up' position marked HOLD. This will result in Q17 being turned on sending its collector "low"; an output which is connected to the D pin of IC1b. This IC is continuously triggered at intervals of 100 microseconds by the 10 kHz clock signal entering on pin 8 and, with its data input now at '0', its \bar{Q} output becomes a '1' and is applied to the bases of Q6, Q8, Q14 and Q15.

5.36 It has already been explained that a '1' on the base of Q6 locks the main gate control bistable, but if the hold has been applied during a gating period the normal events on the gate closing and the resultant triggering of IC1a must be suppressed. Therefore the '1' level at the base of Q8 prevents the sample rate generator from charging,

and Q15 will not produce a 'print-out' command. The new transistor in the sequence is Q14; now turned on it produces a clamp across Q12 and Q13 preventing an update pulse from being generated.

5.37 Returning the HOLD/RESET switch to the centre position turns off Q17 and the next 100 microsecond clock signal, when triggering IC1b, will send the \bar{Q} output of this IC to '0' removing the conditions imposed in the previous paragraph. In addition the negative-going edge is differentiated by C9 to produce a reset pulse and by C10 to produce an update pulse, in this order, to provide a display of zero. The purpose of the monostable Q16 is to eliminate "contact bounce" effect when operating the Hold/Reset switch

5.38 If the SAMPLE RATE control knob is turned fully anti-clockwise until its switch contacts open, it will not be possible for the Sample Rate generator to charge. Under these conditions single shot readings may be taken by depressing and releasing the HOLD/RESET switch. Circuit action is the same as described in paragraphs 5-36 and 5-37.

READOUT AND DISPLAY - 19-0460 and 19-0450

5.39 The readout facility is provided by seven latched b.c.d. decade counters, each of which drives a numerical indicator tube. This arrangement enables a maximum of seven significant figures to be displayed in the standard version of the instrument. At customer's option an additional Decade Assembly can be fitted to provide an eight digit readout.

5.40 The indicator tube displaying the least significant figure is driven by a High Speed Decade Assembly 19-0460. The B.C.D. decade counter on this board consists of four separate bistables, the first of which is a conventional circuit including transistors Q14 and Q15. The remaining three are 'D' Type integrated circuit packages (IC3a, IC4a and IC4b). The discrete component values have been chosen to give the counter the very fast switching that is required of the first decade in the counting circuit. The remaining indicator tubes are driven by standard Readout Assembly boards, (19-0450), each of which employs a single B.C.D. Decade Counter integrated circuit package.

5.41 The Interconnection diagram (Fig. 4.23) shows how the High Speed Decade and the Readout Assemblies are connected in series to provide the counting stage of the instrument. This operates in the conventional way, i.e. as each decade completes a count of ten it resets itself to 'zero' and carries '1' to the next decade.

High Speed Decade Assembly 19-0460

Fig. 4.16

5.42 The output from the Main Gate via pin 10 on the Amplifier Gating Assembly 19-0379 is fed via pin 1 on 19-0460 to the input of the discrete component bistable, Q14 and Q15. This bistable forms the first stage of the 'Divide by Ten' counter (Q14-Q15, IC3a, IC4a and IC4b) and is capable of operating at speeds in excess of 60 MHz.

5.43 Initially, the bistable Q14-Q15 is in the 'Reset' state, i.e. with Q14 turned on and Q15 turned off. The first negative edge is differentiated by C3/R20 and fed

to the base of Q14. As a result Q14 turns off and its collector, the Q output of the bistable, goes to logic '1'. This is then fed via the emitter follower Q13, as the digit '1' output of the counter to the decoding network for the indicator tube. This is marked A¹ on the circuit.

5.44 The \bar{Q} output of the bistable, Q14-Q15, is fed via the emitter follower Q16 to the 'Clock' input (pin 11) of IC3, the second stage of the counter. The logic '1' on the 'D' input (pin 12) is transferred to Q output (pin 9) by the first positive edge from the emitter of Q16 (i.e. the \bar{Q} output of the first bistable). This occurs when the second negative edge is fed from the Main Gate to the input of the first bistable, which via the differentiating network C5 and R26 turns off Q15.

TABLE 4
High Speed Decade Board: Sequence of Operations

'CLOCK' input to IC3a & IC4b	Logic Description	Divide by 10 Counter O/Ps			
		1 (A)	2 (B)	4 (C)	8 (D)
1st	Q output of IC3a goes to logic '1'; Q output of IC4b remains at logic '0' because the 'D' input is held at logic '0'.	0	<u>1</u>	0	0
2nd	Q output of IC3a goes to logic '0'. \bar{Q} output of IC3a going to logic '1' 'clocks' IC4a; the Q output of IC4a goes to logic '1'. The Q output of IC4b remains at logic '0'.	0	0	<u>1</u>	0
3rd	Q output of IC3a goes to logic 1. Transit delays prevent the emitter of Q20 going to logic '1' in time for that level to be transferred to the Q output of IC4b.	0	<u>1</u>	1	0
4th	Q output of IC4b goes to logic '1'. Q outputs of both IC3a and IC4a go to logic '0'. This returns the emitter of Q20 to logic '0'. The Q output of IC4b applies a logic '0' via Q18 onto the 'CLEAR' input of IC3a.	0	0	0	<u>1</u>
5th	Q output of IC3a remains at logic '0' because 'CLEAR' input at logic '0' overrides the 'D' input. Q output of IC4b returns to logic '0'.	0	0	0	0

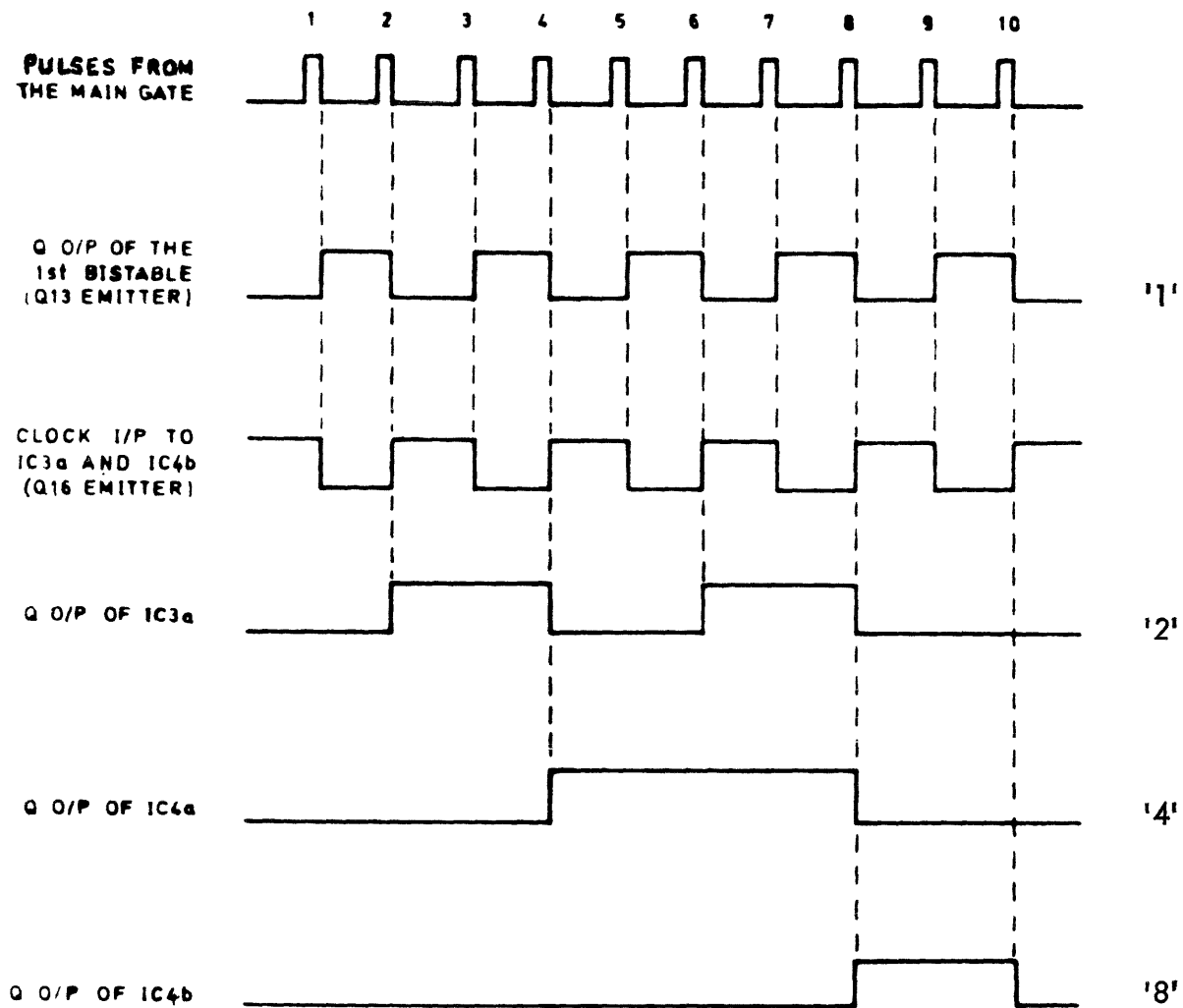

Fig. 2.5 Timing Diagram: High Speed Decade 19-0460

5.45 It can be seen from Fig. 4.19 that the \bar{Q} output is also fed to the 'Clock' input (pin 11) of IC4b. The Q output of IC4b remains at logic '0' because the 'D' input (pin 12) of IC4b is held at logic 0 by the emitter of Q20.

5.46 The Q output of IC3 is fed as the 'digit 2' output of the counter to the decoding network for the indicator tube. Table 4 in conjunction with the timing diagram in Fig. 2.5 explains how IC3a, IC4a and IC4b operate to provide the '2', '4' and '8' outputs from the counter.

5.47 The '8', '4', '2', '1' outputs from the divide-by-ten section are fed to the Quad-Latch element IC2 which stores the information until it is released by an update pulse from pin 17 of the Control Circuit Assembly 19-0356. On release from IC2 the information is decoded by the gates IC1a, b, c and d and by transistor Q1. The BCD information for external readout is taken via R4, R13, R15 and R17. The decoding method is identical to that in the Standard Readout Assembly 19-0450 which is summarised in Table 5. In comparing the two circuits note that there are minor differences in component referencing, for example Transistor Q1 on the High Speed Decade is referenced Q2 on the Standard Readout.

5.48 The B.C.D. Decade Counter IC3 counts the number transitions between logic '1' and logic '0' which occur at its input on pin 14. IC3 counts a total of 10 negative edges before resetting itself to zero and carrying '1' to the next decade, i.e. the next Readout Assembly.

5.49 As the count progresses the 8421 outputs of IC3 are fed into IC2 where the information is held during the counting period. On receipt of the latch pulse at pin 6 of the board the stored information is released to turn on the appropriate transistor which illuminates the required digit in the indicator tube. For a transistor (Q3 to Q12) to conduct, its base must become more positive than its emitter. Table 5 on the next page shows the sequence of operations for obtaining the required conditions for each transistor.

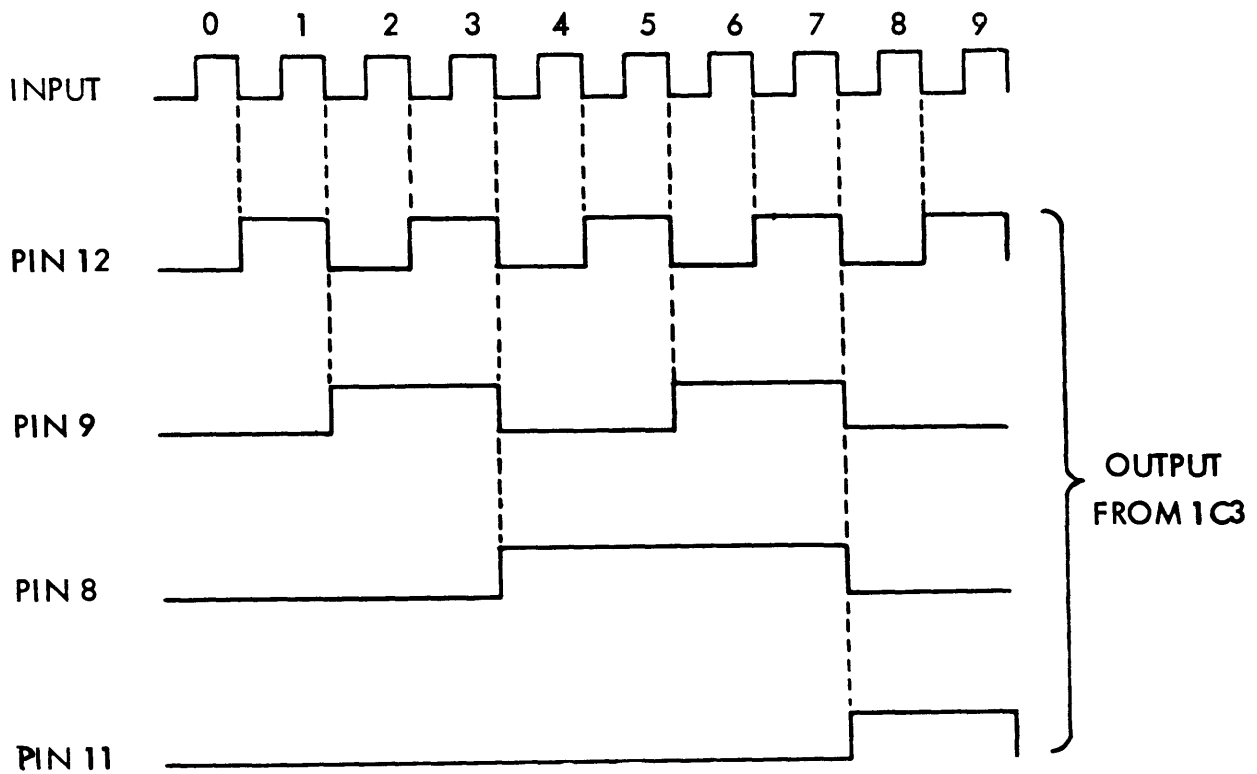

Fig. 2.6 Timing Diagram: Standard Readout Decade

TABLE 5

Standard Readout Board : Sequence of Operations

DIGIT DISPLAYED	'8'	'4'	'2'	'1'	TRANSISTOR	BASE	EMITTER
0	0	0	0	0	Q3	Held at Vcc. Q2 turned off by logic '0' on its base	Goes to logic '0' by the '1' output from IC3
1	0	0	0	1	Q4	As above	Goes to logic '0' by output IC1d
2	0	0	1	0	Q5	Goes to logic '1' by output of IC1d (A)	Goes to logic '0' by output of IC1a
3	0	0	1	1	Q6	Goes to logic '1' by '1' output of IC3(A)	As above
4	0	1	0	0	Q7	Goes to logic '1' by output of IC1d(A)	Goes to logic '0' by output of IC1b
5	0	1	0	1	Q8	Goes to logic '1' by '1' output of IC3(A)	As above
6	0	1	1	0	Q9	Goes to logic '1' by output IC1d(A)	Goes to logic '0' by output of IC1c
7	0	1	1	1	Q10	Goes to logic '1' by '1' output of IC3(A)	As above
8	1	0	0	0	Q11	Goes to logic '1' by the '8' output of IC3	Goes to logic '0' by the '1' output of IC3
9	1	0	0	1	Q12	As above	Goes to logic '0' by the output of IC1d

5.50 The standard readout (19-0450) decades are fitted with decimal point indication in the form of a lamp mounted beside each numerical indicator tube, but only in four of the assemblies is this lamp in circuit. The decimal points are illuminated by switching on an associated series transistor (Q1, Q2, Q3 or Q4) mounted on the Motherboard Assembly (see Fig. 4.23). The appropriate transistor being switched on by a '1' level applied to the base by a contact closure on the Function switch.

Latched Display and Transfer Pulse

5.51 In both the High Speed Decade and the Standard Readout Board, the integrated circuit IC2 provides for a latched display. The transfer pulse which releases the stored information is applied from the Control Circuit Assembly to pin 6 of each Readout Assembly. A slight delay is applied to this transfer pulse by transistor Q7 and its associated time constant network, which is mounted on the Motherboard. (Fig. 4.23). This delay is to ensure, that when operating to maximum count capacity, the transfer pulse to the overspill bistable IC2b is delayed to compensate for transit time through the preceding decade chain.

Overflow Lamp

5.52 The overflow lamp is illuminated by an output (overspill) pulse from the final counting decade. The circuit for translating this overspill pulse into lamp illumination is provided by IC2a, IC2b and transistors Q5 and Q6 on the Motherboard. The appropriate link LK5 or LK6 (Fig. 4.23) is connected according to whether a 7-digit or 8-digit display is fitted.

5.53 The reset pulse from the Control Circuit assembly is inverted by Q5 and applied to the integrated circuit IC2a, setting this JK bistable to $Q = 0$ and $\bar{Q} = 1$. The first pulse out from the final decade is applied to the Trigger input of IC2a and the bistable will toggle to produce outputs of $Q = 1$, $\bar{Q} = 0$. This latter level fed back to the J and K inputs will prevent the bistable from responding to any further pulses from the final decade. The second JK bistable, IC2b, acts as a store responding only to the 'update' commands from the Control Circuit. On receipt of such a signal the level at the J input is transferred to the Q output; if this level is a '1' the transistor Q6 will turn on and illuminate the overflow lamp LP1.

5.54 This is a self contained unit incorporating all the components associated with supply of d.c. power rails to the 9024. It comprises the following items:-

- (a) Mains input socket.
- (b) Mains Filter Assembly 19-0475.
- (c) Mains Voltage Selector.
- (d) Mains Transformer T1.
- (e) Power Stabiliser Assembly 19-0433 (P.C.B.).
- (f) Smoothing Capacitors C1, C3, C6, C10, C13.
- (g) Heat Sink bracket mounting the four 'series regulator' transistors Q2, Q6, Q9, Q12 and the zener diodes D5 and D8. (See Fig. 2.7)

5.55 The assembly provides the following power rails, full wave rectified, smoothed and fused as indicated.

Power Supply Rails

Rail	Supply for:	Fuse Rating
+220V d.c.	Indicator Tubes	FS1 - 60 mA
+12V d.c.	Discrete Circuitry	FS2 - 750 mA
+5V d.c.	TTL Packages	FS3 - 1.5A
-5.4V d.c.	ECL Packages	FS4 - 500mA
-12V d.c.	Discrete Circuitry	FS5 - 500mA

5.56 All except the +220V d.c. rail are stabilised against variations in load current and fluctuations in mains voltage (by conventional series regulation techniques). It is not necessary to stabilise the 220V rail because variations in the voltage due to mains fluctuation will not prevent the indicator tubes, which it supplies, from operating correctly.

Power Stabiliser Assembly 19-0433

5.57 This is a printed circuit board assembly containing a full wave rectifier bridge D1, D2, D4, D6 and D9 (one for each power rail) a bleeder resistor R1 for removing residual charge on the +220V d.c. rail smoothing capacitor C1, and stabilisation circuitry for the +12V, +5V, -5.4V and -12V rails. It does not contain the series regulator transistors Q2, Q6, Q9 and Q10; these are mounted on a separate 'Heat Sink' bracket. The bracket also mounts the zener diodes D5 and D6 which provide overload protection for the TTL and ECL packages, supplied by the +5V d.c. and -5.4V rails respectively.

5.58 The 220 volt output is unregulated, but the +12V, -12V, -5.4V and +5V outputs each have a conventional regulating system which is the same in principle for each rail although the individual circuits differ slightly. Stabilization of each output is achieved by an 'error detection' circuit which, responds to a change in voltage level at the output. Each stabilized output can be pre-set to the required level by the appropriate potentiometer R8, R16, R22 and R30. It is important that this adjustment is made with the mains supply voltage at the correct level.

5.59 It should be noted that the stabilizing circuits are to some extent inter-dependant. For example the +12V and +5V circuits use a common reference diode D3 and the control circuit in the +5V section is connected to +12V via a contact on the Power switch; also the +12V control relies on a connection via R3 and R2 to the +220V rail. Similarly the -12V regulator relies on a +5V supply for its operation. These points could be significant in fault location.

POWER SWITCHING

5.60 The a.c. mains supply is not switched therefore dangerous a.c. voltages are present in the instrument so long as it is connected to an a.c. supply. The Power switch operates in the +220V and +12V outputs. When the power switch is set to ON +12volts is supplied to the +5V stabilizer, thus turning on the +5V output which in turn completes the -12V control circuit. The Frequency Standard oven is supplied with +12V from pin 25 of the p.c.b. irrespective of the setting of the power switch, thus providing immediate accuracy after a period on Standby.

CHAPTER 6

MAINTENANCE

TEST EQUIPMENT REQUIRED

- | | | | |
|-----|-----|---|---|
| 6.1 | (a) | Multimeter: | 20 k Ω /volt D.C. voltage range 0-250
Example: AVO 8. |
| | (b) | Oscilloscope: | Bandwidth: D.C. to 20 MHz
Sensitivity: 50 mV/cm
Example: Tektronix 543, which also provides suitable calibrated output. |
| | (c) | Passive (X10) Probe: | Tektronix P6006, or similar. |
| | (d) | Frequency Standard: | 1MHz, Accurate to 1 part in 10 ⁸ ,
1V r.m.s. (nominal). |
| | (e) | H.F. Signal Generator: | Upper Frequency limit must be not less than
600 MHz. 8 mV to 2V r.m.s. |
| | (f) | L.F. Signal Generator: | To cover frequencies down to 10 Hz. |
| | (g) | Variable Auto-Transformer: | For power supply check. 0-260 V a.c.
Example: Variac. |
| | (h) | Electronic Voltmeter: | To be used if calibrated signal generator
not available.
Example: Racal-Airmec 301A. |
| | (i) | Coaxial Lead: | 50 ohm. BNC to BNC connectors, approx. 1
metre (3 ft) long. |
| | (j) | BNC 'T' piece and 50 Ω
terminating pad: | |

USE OF TEST EQUIPMENT

6.2 The test equipment listed above will be connected directly to the instrument under test and used according to the manufacturers instructions. All signal generator inputs to the 'B' Channel must be made via a 50 ohm terminating pad except when the input is made via the passive probe unit.

REMOVAL OF CASE

6.3 Remove the case of the instrument as described on page 2-1.

WARNING: A.C. MAINS SUPPLY VOLTAGE AND 220 V D.C. ARE EXPOSED WHEN THE INSTRUMENT IS REMOVED FROM ITS CASE.

FUSE CHECK

6.4 Check that fuses are of correct value and securely fitted. See Table 2 on page 2-3 and chassis photograph Fig. 2.7 at the end of this chapter.

NOTE: Care should be taken at all times to avoid the risk of electrical shock. Remember that mains power is connected to the oscillator even when the POWER switch is at STANDBY; to remove all dangerous voltages the power lead must be disconnected from the supply outlet.

GENERAL PERFORMANCE CHECK

6.5 Before commencing any setting-up procedures ensure that the instrument is serviceable and that the power supply voltages are correct.

Self Check

6.6 Carry out the Self Check procedure as given on page 2-2.

POWER SUPPLY CHECK

6.7 Equipment Required:- (a) Multimeter
(b) Variac Unit

Procedure

- (1) Connect the mains supply and set the POWER switch to STANDBY. Note that the 'Standby' lamp illuminates.
- (2) Check that the mains supply voltage is at a satisfactory level. Set the POWER switch to ON.
- (3) Set the Multimeter to the D.C. voltage range (250V or higher) and connect the negative lead to chassis (0V) or to pin 27 on the power supply board.

- (4) Connect the positive lead to the following test points on the power supply board 19-0433 and check the voltages. If necessary adjust R8, R16, R22 and R30 as indicated below:-

<u>Test Point</u>	<u>Required Voltage</u>	<u>Remarks</u>
24	+220V \pm 10V	No adjustment
25	+12V \pm 0.1V	Adjust R8
28	+5V \pm 0.1V	Adjust R16
29	-5.4V \pm 0.1V	Adjust R22
30	-12V \pm 0.1V	Adjust R30

- (5) If a suitable unit, such as a Variac, is available, this should be connected in the a.c. mains supply and the mains voltage varied by plus and minus 6%. At the same time check that the +12V, -12V, -5.4V and +5V readings do not vary be more than $\pm 0.1V$.

(6) Probe Power Supply

Check the Probe power supply at the Probe socket on the front panel. (See pin diagram below). The 0V connection of the multimeter lead may conveniently be made to pin 6 of the A.G.A. board, 19-0379 on which the Probe power filtering components are mounted. (see fig. 2.7). Take care to avoid short circuits if testing at the Probe Power socket.

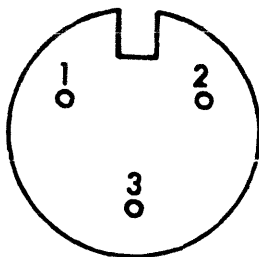

Pin 1 = 0V
 Pin 2 = +12V \pm 0.1V
 Pin 3 = -12V \pm 0.1V

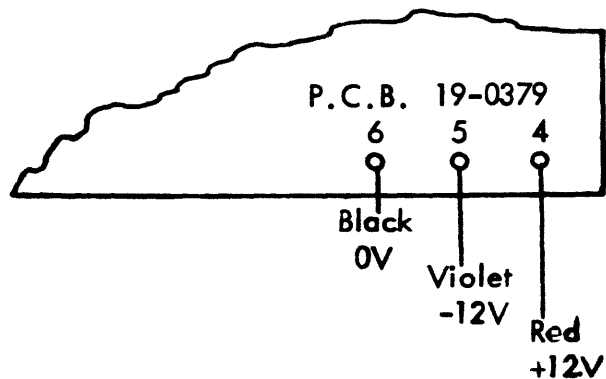

PERFORMANCE TESTS AND SETTING-UP PROCEDURES

NOTE: When feeding a signal generator signal into the Channel 'B' Input socket a BNC 'T' piece with 50 ohm load must be used.

Setting-Up Internal Frequency Standards

6.8 NOTE: Ensure that the link on the oscillator p.c.b. assembly is set for $\div 10$ (10MHz oscillator) or $\div 5$ (5MHz oscillator) as shown in Fig.4.2.

Equipment Required:- Oscilloscope
1MHz external frequency standard, with accuracy better than one part in 10^8 .

Procedure

- (1) Check that the 9024 has been on STANDBY for not less than half an hour. Set the POWER switch to ON.
- (2) Set the INT/EXT switch on the rear panel to INT.
- (3) Connect the 1MHz external standard to the 'External Trigger' input of the oscilloscope.
- (4) Connect the oscilloscope lead to the inner pin of the '1MHz OUTPUT' socket on the rear panel, (Screen to chassis).
- (5) In the Oscillator Type 9400 adjust the mechanical tuning via the aperture in the oscillator case to obtain a stationary trace. Observe the oscilloscope display and check that in a period of 1 minute not more than one cycle of displayed waveform moves past a fixed point on the oscilloscope face.
- (6) If the instrument is fitted with Oscillator Type 842 or 9420 the procedure is the same as (5) above, except that tuning is by means of the "coarse" and "fine" tuning potentiometers accessible via apertures in the rear panel of the instrument.

1MHz Output Amplitude Check

- 6.9
- (1) Terminate the rear panel Terminal 1MHz OUTPUT with a BNC 50 ohm pad.
 - (2) With the INT/EXT switch set to INT connect the oscilloscope to the 1MHz OUTPUT socket on the rear panel and check that an approximately sinusoidal waveform is displayed, with an amplitude of not less than 1 volt peak-to-peak. If necessary adjust the core of transformer T1 on the oscillator p.c.b. (fig.4.12) to obtain the maximum output level.

- (3) Disconnect the test equipment.

External Frequency Standard Input

- 6.10 (1) Set the Sensitivity switch to the CHECK position and the FUNCTION switch to the '1 sec kHz' position.
- (2) Set the SAMPLE RATE control clockwise.
- (3) Connect the 1MHz external standard at 1 volt r.m.s. to the rear panel socket EXT. FREQUENCY INPUT.
- (4) Set the rear panel INT/EXT switch to EXT.
- (5) Check that the 9024 displays a reading of 1000.000 ± 1 count.

Pre-Amplifier Assembly (11-0339)

Fig. 4.1, 4.4

6.11 The pre-amplifier assembly comprises the switch together with an attenuator board (19-0235) and a pre-amplifier board (19-0236) which are contained in the metal case immediately behind the Channel B Sensitivity control.

Equipment Required

- (a) Oscilloscope: Tektronix 543 recommended.
- (b) Passive (x10) Probe: Tektronix 6006 or similar.
- (c) A source of 1kHz calibrated square-wave voltages at 0.1V, 1V and 10V peak-to-peak is required. The calibrated output from the Tektronix 543 is very suitable. Alternatively a square-wave generator with a rise time of approximately one microsecond should be used.
- (d) H.F. Signal Generator.
- (e) BNC 'T' connector with 50 ohm load.

6.12 Setting the Attenuator

- (1) Remove the cover from the Pre-Amplifier assembly.
- (2) Set the SENSITIVITY switch to the .01 position and the HOLD/RESET switch to HOLD. Switch on the power.
- (3) Connect the passive probe to the input socket of the 9024.
- (4) Set the calibrated square-wave source to give an output of 1kHz at 0.1 volts peak-to-peak.
- (5) Connect the tip of the passive probe to the output of the square-wave source.

- (6) Connect the oscilloscope probe to pin 1 (input) and earth on the pre-amplifier board 19-0236 and check that the amplitude is 10mV peak-to-peak. If necessary adjust the passive probe to give an optimum square-wave. (19-0236 is the upper of the two boards).
- (7) Set the Channel B Sensitivity switch to the 0.1 position.
- (8) Set the calibrated square-wave source to 1 volt peak-to-peak.
- (9) With the oscilloscope probe connected as in (6) above, adjust the capacitor C3 on the attenuator board 19-0235 (via the hole in the upper board) to provide an optimum square-wave on the oscilloscope display with an amplitude of 10 mV peak-to-peak.
- (10) Set the Channel B Sensitivity switch to the 1V position and the calibrated square-wave source to 10 volts peak-to-peak.
- (11) Repeat the procedure given in (9) but adjusting C5 via the appropriate hole in the upper board.
- (12) Disconnect the square-wave source and passive probe.

6.13 Pre-Amplifier Frequency Response

- (1) Set the Sensitivity switch to the .01 position and the HOLD/RESET switch to HOLD. Switch on the power.
- (2) Connect the H.F. signal generator to the input socket of the 9024 via the 'T' piece with 50 ohm load, and apply a signal of 10mV r.m.s. at a frequency of 10 MHz.
- (3) With an oscilloscope, or electronic or digital voltmeter, check the r.m.s. level at the rear of the Channel B input socket on the 9024 and also the output level from the pre-amplifier. (A convenient point is between pin 7 and chassis on the A.G.A. 19-0379). Calculate the amplifier gain which should be $8 \text{ dB} \pm 3 \text{ dB}$.
- (4) Repeat (3) but at a frequency of 50 MHz.

Attenuator 19-0620

Fig. 4.17

- 6.14 Equipment Required:-
- (a) Signal Generator. (500 MHz).
 - (b) 'T' piece and 50Ω load.

Procedure

- (1) Apply 480 MHz at 10mV r.m.s. from the signal generator via the 'T' piece and 50Ω load to Channel A input socket.

- (2) Set Channel A Sensitivity switch to 0.01 V and switch the power on.
- (3) Reduce the input from the signal generator until the display ceases to operate, then carefully increase the input until the display just operates (Threshold). Note the input level setting on the signal generator.
- (4) Set the Channel A Sensitivity switch to 0.1 V and carefully increase the input until the display just operates. Note the input level setting on the signal generator.
- (5) The input voltage level required to operate the display in (4) should be 20 dB \pm 3 dB higher than that required to operate the display in (3).

Amplifier Divider Assembly 19-0630

Fig. 4.20

- 6.15 The amplifier divider assembly comprises the input amplifier a shaper circuit and a divide by ten integrated circuit.

Equipment Required

- (a) H.F. signal generator with frequency range up to 600 MHz.
- (b) Electronic Voltmeter (for gain check).
- (c) Oscilloscope (for shaper adjustment).

6.16 Sensitivity (Shaper) Adjustment

- (1) From the signal generator apply 10 MHz at 10 mV r.m.s. to Input Socket A on the instrument.
- (2) Set the Channel A Sensitivity switch to 0.01V.
- (3) Connect the high impedance probe of an oscilloscope to the junction of C18/R31.
- (4) Adjust the potentiometer R24 to the centre of the movement which produces a 1:1 mark-space ratio on the rectangular waveform. The amplitude should be approximately 500 mV peak-to-peak.

6.17 Wideband Amplifier Check

NOTE: For satisfactory adjustment of the bandwidth, using trimmers C3 and C8, the use of a sweep scanner such as a "Polyskanner" is essential (See para. 6.28). Using basic servicing equipment the amplifier gain can be checked only at the lower end of the band. If a loss of sensitivity at the higher frequencies is suspected, the board should be returned to Racal Instruments Limited, or an approved Agent.

Procedure

- (1) Apply a signal of 10 MHz at 10mV r.m.s. from the signal generator to Input Socket A.
- (2) Set the Sensitivity switch to 0.01V.
- (3) Connect the electronic voltmeter to base of Q6 (junction of R26/C16) via a 0.1 μ F capacitor in series with a 100 ohm resistor. All leads are to be as short as possible.
- (4) Check that the overall gain is 14 dB \pm 3 dB.
- (5) Repeat the test with an input of 50 MHz.
- (6) The above tests will establish the basic serviceability of the board, for a more advanced procedure employing a sweep scanner refer to para. 6.28.

Amplifier Gating Assembly 19-0379

6.18 The nominal gain of the wideband amplifier together with the 'B' Channel pre-amplifier 32 dB \pm 4dB at 10 MHz rising to 34 dB \pm 4dB at 60 MHz. The gain is measured between the front panel input socket and pin 20 on assembly 19-0379.

Equipment Required

- (a) H.F. signal generator with frequency range up to 60 MHz.
- (b) Electronic voltmeter (for gain check).
- (c) Oscilloscope (for Shaper check).

6.19 Amplifier Gain Check

- (1) Set the signal generator to 10 MHz and apply a signal of 10 mV r.m.s. via the 'T' piece and 50 ohm load, to the input socket (Channel B) of the 9024
- (2) On the board 19-0379 connect the electronic voltmeter between pin 20 (TP1) and chassis.
- (3) Check that the overall gain between the input socket and TP1 is 32 dB \pm 4 dB. If necessary adjust C11 and C18 to obtain this gain.
- (4) Change the signal generator frequency to 60 MHz at 10mV r.m.s. Repeat the measurements as in (3) and check that the gain is 34 dB \pm 4 dB. Making fine adjustment to C11 and C18 if required.
- (5) Repeat (3) with 10 MHz input and (4) with 60 MHz input until the gain figures are obtained without further adjustment of C11 and C18.
- (6) Disconnect the electronic voltmeter.

TABLE 6

'B' Channel Sensitivity Check:

Function Switch Gate Time	Input Frequency	Remarks
1.0 sec	10Hz	Sensitivity Switch set to 0.01V
1.0 sec	100Hz	
0.10 sec	1kHz	
0.10 sec	10kHz	
0.01 sec	100kHz	
0.01 sec	1MHz	Input level to be not higher than 10mV r.m.s.
0.01 sec	10MHz	
0.01 sec	25MHz	
0.01 sec	60MHz	

(6) Transfer the signal generator to the Channel 'A' input socket (50 ohm load not required).

(7) Repeat operation (5) but in accordance with the details in Table 7 below.

TABLE 7

'A' Channel Sensitivity Check:

Function and Sensitivity Switch Settings	Input Frequency (MHz)	Input Level
Gate Time 0.01 secs and Sensitivity Setting 0.01V for all tests	10	10mV r.m.s.
	100	
	200	
	300	
	400	
	500	100mV r.m.s.
	550	
	600	

Display Timing Check

6.22 Equipment Required: Oscilloscope

Procedure

- (1) Set the Channel 'B' Sensitivity switch to CHECK, and the Channel Selector switch to Channel 'B'.
- (2) Set the Function switch to Gate Time 0.01 sec. and check that the display reads 0010 000 \pm 1 count.
- (3) Turn the SAMPLE RATE control to maximum clockwise position and observe the fast sample rate (short display time).
- (4) Connect the oscilloscope probe to the collector of transistor Q11 on the control circuit assembly 19-0356 (screen to 0V).
- (5) Turn the SAMPLE RATE control anti-clockwise, at the same time observing on the oscilloscope that the period of the reset pulse changes from less than 250 milliseconds to 10 seconds \pm 1 second. Finally turn the control to the SINGLE SHOT (Click) position.
- (6) While operating on Single Shot, briefly depress the HOLD/RESET switch to the RESET position and release, noting that this updates the display.
- (7) Set the Function switch to Gate Time 10 sec. and note that the Overflow lamp illuminates at the conclusion of the count period.

Data Output Check

6.23 This check applies only to instruments fitted with Option 01 or Option 02.

Equipment Required:

- (a) Suitable printer or simulator
- (b) Signal generator.
 - (1) Connect the printer via the 50-way connector on the rear panel designated BCD.
 - (2) Connect the signal generator to the Channel 'B' input via the 50 ohm 'T' piece. Set the Channel Selector switch to 'B'.
 - (3) Set the Channel 'B' Sensitivity switch as appropriate and apply a signal generator output to display all digits in turn. Set the Function Switch as required. Observe displayed numbers and decimal points and check that the printout is identical.

- (4) Select 10 second gate on the 9024 and check that the Overflow lamp illuminates. Check that remote overflow indication is obtained (if this facility is connected).

Remote Control Check (Option 02)

- 6.24 This information will be included with the Appendices at the rear of the handbook when required.

MISCELLANEOUS SERVICING INFORMATION

Lamp Changing

- 6.25 To change the Overflow and Standby indicator lamps unscrew the lens and lift out the bulb with collet attached. Transfer this collet to the new bulb before fitting.

Tunnel Diode Replacement

- 6.26 The tunnel diode D2 in the Amplifier Divider Assembly 19-0630 is fitted by a special technique to ensure optimum performance. If servicing of this component becomes necessary it is recommended that the work be carried out by Racal Instruments Service Department.

S U P P L E M E N T A R Y A L I G N M E N T P R O C E D U R E

AMPLIFIER DIVIDER ASSEMBLY: 19-0630

Overall Gain and Response Check Using Sweep Scanner

NOTE: It is assumed that the user is fully conversant with the type of sweep scanner to be used and that the Amplifier Divider Board is mounted in a serviceable instrument.

6.27 Equipment Required:

- (a) Sweep Scanner such as a Knott "Polyskanner".
- (b) Coaxial lead with BNC plug at each end.
- (c) Coaxial lead with BNC plug at one end and open wire at the other, with 100 ohm resistor and 0.1 μ F capacitor wired in series.

6.28 Procedure

- (1) Allow the Sweep Scanner to warm up and set the controls for H.F. operation with output attenuation of -25dB and frequency sweep (initially) of 0.5MHz to 50MHz.

- (2) Set up the Sweep Scanner to an appropriate input reference for gain measurement.
- (3) Connect the R.F. OUTPUT socket of the Sweep Scanner to the INPUT socket of the 9024 under test.
- (4) On the 9024 set the 'A' Channel SENSITIVITY switch to the most sensitive setting. (0.01V).
- (5) Using the open-ended coaxial lead, with the 100 ohm resistor and 0.1 μ F capacitor wired in series, connect the Sweep Scanner R.F. Input socket to the base of transistor Q6 (junction of R26/C16) on the Amplifier Divider Board. The braiding should be lightly soldered to the adjacent OV track during this test.
- (6) Switch on the power to the 9024 under test and carry out the amplifier frequency response check over the bandwidth 10MHz to 600MHz. If necessary adjust the trimmer capacitors C3 and C8 on the Amplifier Divider Board to achieve maximum bandwidth with flat response.
- (7) Check the amplifier gain which should be 14dB \pm 4dB from 10MHz to 400MHz, falling to 0dB gain at approximately 550MHz.

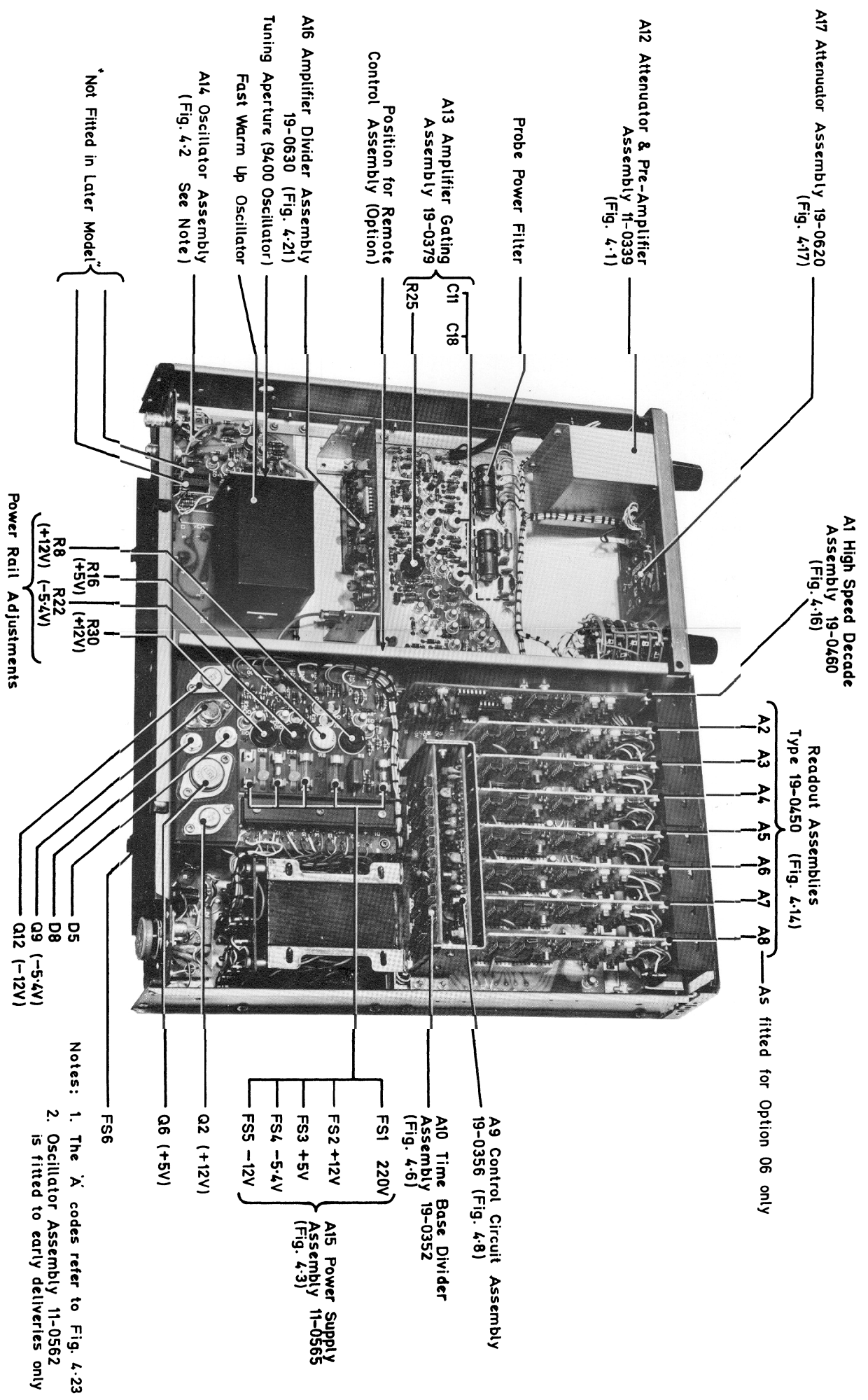

Notes: 1. The 'A' codes refer to Fig. 4-23
 2. Oscillator Assembly 11-0562 is fitted to early deliveries only

Service View: Chassis Upperside

WOH2078
A B

Fig. 2-7

PARTS LIST

<u>CONTENTS</u>	<u>Page</u>
Pre Amplifier Assembly	11-0339... 7-2
Oscillator Assembly	19-0636... 7-2
Power Supply Assembly	11-0565... 7-3
Chassis Mounted Components	11-0733... 7-4
Attenuator Assembly	19-0235... 7-4
Pre-Amplifier Assembly	19-0236... 7-5
Time Base Divider Assembly	19-0352... 7-6
Control Circuit Assembly	19-0356... 7-6
Amplifier Gating Assembly	19-0379... 7-8
Power Supply Stabilizer Board	19-0433... 7-10
Standard Readout Assembly	19-0450... 7-11
High Speed Decade Assembly	19-0460... 7-12
Mains Filter Assembly	19-0475... 7-13
Attenuator Board Assembly	19-0620... 7-13
Remote Control Assembly (Option)	19-0628... 7-14
Amplifier Divider Assembly	19-0630... 7-14
Motherboard Assembly	19-0634... 7-16
Oscillator P.C.B. Assembly	19-0636... 7-17
Options Parts List Summary	7-18

Replacement Resistors

The Erie Type 15 composition resistor which has 0.4 inch (10mm) lead spacing may be replaced by the Mullard Type CR16 Carbon Film type. In cases where the printed circuit board has resistor mounting holes with 0.5 inch (12.5mm) spacing, the recommended replacement resistor is the Mullard CR25, (330mW, carbon film type. The Mullard CR25 may also replace those $\frac{1}{4}$ watt 5% metal oxide resistors which have 0.5 inch hole spacing.

Part No.	Description	Rating	Tolerance %	Value	Component References	Vendor
----------	-------------	--------	-------------	-------	----------------------	--------

PRE-AMPLIFIER ASSEMBLY, 11-0339

(also refer to Assemblies 19-0235 and 19-0236)

<u>Resistors</u>		watts				
20-0100	Composition	1/10	10	10	R21, R22	Erie 15
20-0560	Composition	1/10	10	56	R6	Erie 15
<u>Capacitors</u>						
21-4528	Polyester	400V		.047 μ	C1	Mullard C296-AC-A47K
21-1616	Ceramic	12V	10	0.1 μ	C8, C22, C23	Murata DD.600.BC.12
21-5501	Feed thru				C19, C20, C21	Erie K2600/361
23-3030	Connector-BNC					Greenpar UG 1094/AU
17-0029	Switch-Rotary					Racal Inst.

OSCILLATOR ASSEMBLY 11-0770 (See NOTE below)

9400	5 MHz Fast warm up Oscillator Type 9400					
19-0636	P.C.B. Assembly. See Parts List page 7-17					
23-3005	BNC Sockets, Bulkhead. 1 MHz Ext/Int.					Amphenol UG-1094/U
23-3074	Valve Base B7G					Carr Fastener
23-4042	Slide Switch d.p.d.t.					Racal Insts.

NOTE: In later models the components listed under Assembly 11-0770 are transferred to the Main Chassis Parts List.

Cct. Ref.	Description	Rat	Tol. %	Value	Component References	Manufacturer
<u>POWER SUPPLY ASSEMBLY 11-0565</u>						
NOTE: Components on the Stabiliser p.c.b. are shown in the Parts List 19-0433 and the Mains Filter in 19-0475.						
<u>Capacitors</u>						
21-0587	Electrolytic	350V		33 μ	C1	I, T. T. EN12.12
21-0577	Electrolytic	16V	-10+50	3300 μ	C10	Mullard 071-15332
21-0576	Electrolytic	25V	-10+50	2200 μ	C3, C13	Mullard 071-16222
21-0578	Electrolytic	16V	-10+50	10,000 μ	C6	Mullard 071-15103
<u>Diodes</u>						
22-1845	Volt Reg. (Stud Anode)		5	6.8V	D5	Texas IS.6006.A
22-1846	Volt Reg. (Stud Cathode)		5	6.8V	D8	Texas IS.6006.RA
<u>Transistors</u>						
22-6012	Silicon npn (High Power)				Q6	Motorola 2N 3055
22-6016	Silicon npn (High Power)				Q2, Q9, Q12	R.C.A. 2N 3054
<u>Miscellaneous</u>						
17-4027	Transformer				T1	Racal Instruments
19-0433	Power Supply Stabilizer Board					Racal Instruments
19-0475	Mains Filter Assembly					Racal Instruments
23-0000	Fuselink			60mA	FS1	Bulgin F270
23-0004	Fuselink			500mA	FS4, FS5	Bulgin F270
23-0005	Fuselink			750mA	FS2	Bulgin F270
23-0007	Fuselink			1.5A	FS3	Bulgin F270
23-0031	Fuselink	200-250V		250mA	FS6	Bulgin F286/0.25
Anti-Surge						
23-0022	Fuselink	100-130V		500mA	FS6	Bulgin F286/0.50
Anti-Surge						
23-0014	Fuse Holder (For FS6)					Bulgin F296
23-3036	Mains Inlet - 3 pin plug					Bulgin P429
23-3038	Socket (Free) - 3 way (mates with 23-3036)					Bulgin P430
23-9022	Voltage Selector					Carr Fastener 81/118

Cct Ref.	Description	Rat	Tol. %	Value	Component References	Manufacturer
----------	-------------	-----	--------	-------	----------------------	--------------

CHASSIS MOUNTED COMPONENTS: Parts List 11-0733

NOTE: The following miscellaneous items are not located on any single assembly. For Motherboard components refer to Parts List 19-0634.

17-0051	Function Switch					Racal Instruments
23-4044	Switch: Hold/Reset s.p.d.t. Toggle				S2	Waycom MST205H
23-4043	Switch: Power d.p.d.t. Toggle				S3	Waycom MST205N
23-4042	Switch: Channel Select d.p.d.t.				S5	Jeanrenaud 51M
20-6593	Potentiometer inverse log with switch: Sample Rate 500K				R1/S4	Erie 53
26-3007	Lamps: Standby and Overflow 12V			.06A	LPI, LP2	Thorn Bendix L1343
23-1015	Lampholder for LP1, LP2 (Amber)					Sloan 102.SK1
23-3069	Socket: Probe Power					Sealectro D102A052
23-5125	Edge Connector 12 way					Carr. Fastener

ATTENUATOR ASSEMBLY 19-0235

(Part of Assembly 11-0339)

<u>Resistors</u>		watt				
20-0220	Composition	1/10	10	22	R23	Erie 15
20-1501	Film	$\frac{1}{4}$	1	100k	R3, R5	Erie 15
20-1502	Film	$\frac{1}{4}$	1	910k	R2, R4	Erie 15
20-3104	Metal Oxide	$\frac{1}{2}$	5	100k	R1	Erie MO5
<u>Capacitors</u>						
21-1008	Tantalum	15V	10	150 μ	C7	S.T.C.472/LWA/403FAA
21-1515	Ceramic		10	39p	C4	Erie 831 N1500
21-1517	Ceramic		10	56p	C6	Erie 831 N1500
21-1526	Ceramic		10	330p	C2	Erie 831 N5600
21-6003	Trimmer			2-6p	C3, C5	Steatite Ins. 10S-Triko 06

Cct. Ref.	Description	Rat	Tol. %	Value	Component References	Manufacturer
-----------	-------------	-----	--------	-------	----------------------	--------------

PRE-AMPLIFIER ASSEMBLY, 19-0236

(Part of Assembly 11-0339)

<u>Resistors</u>		watts				
20-0100	Composition	1/10	10	10	R19	Erie 15
20-0106	Composition	1/10	10	10M	R7	Erie 15
20-0332	Composition	1/10	10	3.3k	R8	Erie 15
20-0330	Composition	1/10	10	33	R14	Erie 15
20-2102	Metal Oxide	$\frac{1}{4}$	5	1k	R13	Erie MO4
20-2153	Metal Oxide	$\frac{1}{4}$	5	15k	R16	Erie MO4
20-2221	Metal Oxide	$\frac{1}{4}$	5	220	R9	Erie MO4
20-2271	Metal Oxide	$\frac{1}{4}$	5	270	R20	Erie MO4
20-2332	Metal Oxide	$\frac{1}{4}$	5	3.3k	R12	Erie MO4
20-2471	Metal Oxide	$\frac{1}{4}$	5	470	R17	Erie MO4
20-2560	Metal Oxide	$\frac{1}{4}$	5	56	R18	Erie MO4
20-2561	Metal Oxide	$\frac{1}{4}$	5	560	R11	Erie MO4
20-2681	Metal Oxide	$\frac{1}{4}$	5	680	R10	Erie MO4
20-2821	Metal Oxide	$\frac{1}{4}$	5	820	R15	Erie MO4
<u>Capacitors</u>						
21-1002	Tantalum	20V	20	10 μ	C15, C17	Union Carbide K.10E20
20-1017	Tantalum			22 μ	C12, C24	Mullard C421/AMDP22
21-1512	Ceramic			22p	C14	Erie 831 N470
21-4506	Polystyrene	100V		0.1 μ	C9	Waycom MKS
21-1616	Ceramic	12V	10	0.1 μ	C10, C11, C13, C16, C18	Murata DD.600.BC12
<u>Diodes</u>						
22-1018	Silicon				D5, D6	Hewlett-Packard HPA2900
22-1029	Silicon				D1, D2	S. T. C. IN 4149
22-1807	Voltage Regulator	4.7V			D7	Mullard BZY88-C4V7
22-1809	Voltage Regulator	5.6V			D4	Mullard BZY88-C5V6
22-1811	Voltage Regulator	6.8V			D3	Mullard BZY88-C6V8

Cct. Ref.	Description	Rat	Tol. %	Value	Component References	Manufacturer
<u>19-0236 (continued)</u>						
<u>Transistors</u>						
22-6017	Silicon npn				Q2, Q4	Mullard 2N 2369
22-6039	Silicon npn				Q3, Q5	Mullard BFY 90
22-6040	F.E.T.				Q1	Motorola 2N 4416
22-6057	Silicon (used as diodes)				Q6, Q7	Ferranti ZTX 342
23-8000	Ferrite Bead				X1 (to be fitted to base of Q5) X2 (fitted on Collector of Q4)	Mullard FX 1214

TIME BASE DIVIDER ASSEMBLY, 19-0352

<u>Resistors</u>						
		watts				
20-0102	Composition	1/10	10	1k	R2, R4	Erie 15
20-0472	Composition	1/10	10	4.7k	R1, R3	Erie 15
<u>Capacitors</u>						
21-1003	Tantalum	10V	20	15 μ	C1	Union Carbide K15E10
21-1616	Ceramic	12V	10	0.1 μ	C2	Murata DD.600 BC12
<u>Integrated Circuits</u>						
22-4044	Quad 2 input pos. Nand Gate				IC1	Motorola 7400
22-4049	Decade Counter				IC7, IC8, IC9, IC10, IC11, IC12, IC13	Motorola 7490
22-4053	Triple 3 input Ps. Nand Gate				IC2, IC3, IC6	Motorola 7410
22-4056	Dual 4 input Pos. Nand Gate				IC5	Motorola 7420
22-4055	Single 8 input pos. Nand Gate				IC4	Motorola 7430

<u>Transistors</u>						
22-6017	Silicon npn				Q1, Q2	Motorola 2N 2369

CONTROL CIRCUIT ASSEMBLY 19-0356

<u>Resistors</u>						
		watts				
20-0101	Composition	1/10	10	100	R23, R24	Erie 15
20-0102	Composition	1/10	10	1k	R15, R19, R32, R33, R34, R47, R49, R50, R52, R54	Erie 15

Cct. Ref.	Description	Rat	Tol. %	Value	Component References	Manufacturer
<u>19-0356 (continued)</u>						
<u>Resistors</u>						
20-0103	Composition	1/10	10	10k	R10, R16, R18, R20, R21, R28	Erie 15
20-0152	Composition	1/10	10	1.5k	R1, R4, R5, R7, R11, R46	Erie 15
20-0181	Composition	1/10	10	180	R30, R40	Erie 15
20-0222	Composition	1/10	10	2.2k	R2, R6, R13, R48	Erie 15
20-0821	Composition	1/10	10	820	R8	Erie 15
20-0392	Composition	1/10	10	3.9k	R29	Erie 15
20-0272	Composition	1/10	10	2.7k	R14	Erie 15
20-0471	Composition	1/10	10	470	R25, R31, R39	Erie 15
20-0123	Composition	1/10	10	12k	R45	Erie 15
20-0472	Composition	1/10	10	4.7k	R22, R36, R37, R38, R41, R42, R43, R44, R51	Erie 15
20-0681	Composition	1/10	10	680	R35	Erie 15
20-2102	Metal Oxide	$\frac{1}{4}$	5	1k	R27	Erie MO4
20-2152	Metal Oxide	$\frac{1}{4}$	5	1.5k	R26	Erie MO4
20-2221	Metal Oxide	$\frac{1}{4}$	5	220	R3, R9, R12, R17	Erie MO4
20-2771	Metal Oxide	$\frac{1}{4}$	5	270	R53	Erie MO4
<u>Capacitors</u>						
21-1510	Ceramic		10	15p	C1, C4	Erie 831-N150
20-1513	Ceramic		10	27p	C2, C3	Erie 831-N650
21-1520	Ceramic		10	100p	C18	Erie 831-N3300
21-1532	Ceramic		20	1000p	C10, C12	Erie 831-K350081
21-1536	Ceramic		25	2200p	C9,	Erie 831-K7004
21-1616	Ceramic	12V		0.1 μ	C5, C8, C14, C15, C16	Murata DD 600 BC12
21-1508	Ceramic		+10	10p	C17	Erie 831-N.P.O.
21-1003	Tantalum	10V		15 μ	C7	Union Carbide K15E10
21-1004	Tantalum	6.3V		22 μ	C6, C13	Union Carbide K22E6
21-1545	Ceramic	25V	+50 -25	.01 μ	C11	Erie 831/T/25V
<u>Diodes</u>						
22-1029	Silicon				D1-D18 incl.	I.T.T. IN 4149
<u>Transistors</u>						
22-6017	Silicon npn				Q1-Q7 incl., Q10, Q11, Q12, Q13, Q14, Q16, Q17, Q18, Q19	Motorola SN 2369

Cct. Ref.	Description	Rat	Tol. %	Value	Component References	Manufacturers
<u>19-0356 (continued)</u>						
<u>Transistors</u>						
22-6041	Silicon npn				Q8, Q15	Mullard BC109
22-6058	Silicon npn				Q9	Transitron TES-014

<u>Integrated Circuits</u>						
22-4048	Dual 'D' Type Bistable				IC1	Motorola 7474

AMPLIFIER GATING ASSEMBLY 19-0379

<u>Resistors</u>						
20-0102	Composition	1/10	10	1k	R43, R45, R47, R55, R60, R63	Erie 15
20-0103	Composition	1/10	10	10k	R59	Erie 15
20-0121	Composition	1/10	10	120	R7, R39	Erie 15
20-0151	Composition	1/10	10	150	R5	Erie 15
20-0222	Composition	1/10	10	2.2k	R6	Erie 15
20-0181	Composition	1/10	10	180	R14	Erie 15
20-0182	Composition	1/10	10	1.8k	R49	Erie 15
20-0221	Composition	1/10	10	220	R50, R53	Erie 15
20-0272	Composition	1/10	10	2.7k	R8, R48, R51	Erie 15
20-0331	Composition	1/10	10	330	R42	Erie 15
20-0152	Carbon Film	1/5	10	1.5k	R54	Mullard CR16
20-0333	Composition	1/10	10	33k	R2, R64	Erie 15
20-0391	Composition	1/10	10	390	R22	Erie 15
20-0470	Composition	1/10	10	47	R34, R62	Erie 15
20-0471	Composition	1/10	10	470	R16, R38	Erie 15
20-0472	Composition	1/10	10	4.7k	R15	Erie 15
20-0680	Composition	1/10	10	68	R21	Erie 15
20-0681	Composition	1/10	10	680	R57, R58	Erie 15
20-0682	Composition	1/10	10	6.8k	R1	Erie 15
20-0821	Composition	1/10	10	820	R9, R17	Erie 15
20-2101	Metal Oxide	$\frac{1}{4}$	5	100	R29, R33	Erie MO4
20-2102	Metal Oxide	$\frac{1}{4}$	5	1k	R12, R20, R31, R35	Erie MO4
20-2181	Metal Oxide	$\frac{1}{4}$	5	180	R3	Erie MO4
20-2221	Metal Oxide	$\frac{1}{4}$	5	220	R37, R46, R61	Erie MO4
20-2222	Metal Oxide	$\frac{1}{4}$	5	2.2k	R36	Erie MO4
20-2271	Metal Oxide	$\frac{1}{4}$	5	270	R30, R32	Erie MO4
20-2331	Metal Oxide	$\frac{1}{4}$	5	330	R41	Erie MO4
20-2391	Metal Oxide	$\frac{1}{4}$	5	390	R18	Erie MO4
20-2560	Metal Oxide	$\frac{1}{4}$	5	56	R13, R23	Erie MO4
20-2471	Metal Oxide	$\frac{1}{4}$	5	470	R10, R27	Erie MO4

Cct. Ref.	Description	Rat	Tol. %	Value	Component References	Manufacturer
<u>19-0379 (continued)</u>						
<u>Resistors</u>						
20-2681	Metal Oxide	$\frac{1}{4}$	5	680	R28	Erie MO4
20-2820	Metal Oxide	$\frac{1}{4}$	5	82	R11, R19	Erie MO4
20-4049	Metal Oxide	$\frac{1}{4}$	2	3.9k	R24	Electrosil TR4
20-4066	Metal Oxide	$\frac{1}{4}$	2	8.2k	R26	Electrosil TR4
20-6543	Variable			2.2k	R25	Plessey 404/8/02854/ NP
<u>Capacitors</u>						
21-1513	Ceramic		20	27p	C26	Erie 831-N650
21-1508	Ceramic			10p	C31	Erie 831-NPO
21-1547	Ceramic		+50-25	.033 μ	C32	Erie 831/T/18V
21-1515	Ceramic		20	39p	C12, C19	Erie 831/N1500
21-1520	Ceramic		20	100p	C2	Erie 831-N3300
21-1522	Ceramic		20	150p	C29	Erie 831-N3300
21-1526	Ceramic		20	330p	C3	Erie 831-N5600
21-1517	Ceramic		20	56p	C33	Erie 831-N1500
21-1616	Ceramic	12V	10	0.1 μ	C1, C4, C5, C7, C9, C14, C15, C16, C21, C25, C28, C30, C34-C37 incl. C40	Murata DD. 600. BC. 12
21-1003	Tantalum	10V		15 μ	C6, C8, C10, C17	Union Carbide K15E10
21-1004	Tantalum	6V		22 μ	C27	Union Carbide K22E6
21-1017	Tantalum	15V		22 μ	C38, C39	Mullard C421/AM/FP4.7
21-0514	Tantalum	6V		500 μ	C13, C20	Hunts MEF15AT
21-6000	Trimmer			10/40p	C11, C18	Steatite Ins. 10STriko06
<u>Transistors</u>						
22-6018	Silicon pnp				Q1	Motorola MPS 3640
22-6017	Silicon npn				Q6-Q21 incl	Motorola 2N2369
22-6009	Silicon npn				Q3, Q5,	Motorola 2N4124
22-6019	Silicon npn				Q2, Q4	Mullard 2N 918
<u>Diodes</u>						
22-0001	Germanium				D5, D10, D12	Hughes HD 1870
22-1029	Silicon				D1, D4, D11	I. T. T. 1N 4149
22-1809	Voltage Regulators	5.6V			D9	Mullard BZY 88-C5V6
22-1810	Voltage Regulators	6.2V			D7	Mullard BZY 88-C6V2
22-1814	Voltage Regulators	9.1V			D2, D3, D6, D8	Mullard BZY 88-C9V2

Cct. Ref.	Description	Rat	Tol. %	Value	Component References	Manufacturer
<u>19-0379 (continued)</u>						
<u>Miscellaneous</u>						
23-8000	Ferrite Bead				X1, X2, X3, X4	Mullard FX 1242
NOTE: X4 on Emitter of Q8						
23-7012	Inductor			4.7 μ H	L1, L2	Painton 58/10/0009/10

POWER SUPPLY STABILIZER BOARD: 19-0433

(Part of Power Supply Assembly 11-0565)

<u>Resistors</u>		watts				
20-3224	Metal Oxide	$\frac{1}{4}$	5	220k	R1	Welwyn MR5
20-0474	Composition	1/10	10	470k	R2, R3	Erie 15
20-0100	Composition	1/10	10	10	R4, R12, R19, R26	Erie 15
20-0470	Composition	1/10	10	47	R5	Erie 15
20-0471	Composition	1/10	10	470	R6, R13	Erie 15
20-2332	Metal Oxide	$\frac{1}{4}$	5	3.3k	R7, R29	Erie MO4
20-6546	Variable	$\frac{1}{4}$	20	10k	R8, R30	Plessey 404/8/02857/MP
20-2472	Metal Oxide	$\frac{1}{4}$	5	4.7k	R9, R31	Erie MO4
20-2222	Metal Oxide	$\frac{1}{4}$	5	2.2k	R10, R32	Erie MO4
20-0103	Composition	1/10	10	10k	R11, R18, R25	Erie 15
20-2100	Metal Oxide	$\frac{1}{4}$	5	10	R14	Erie MO4
20-2121	Metal Oxide	$\frac{1}{4}$	5	120	R15, R23	Erie MO4
20-6541	Variable	$\frac{1}{4}$	20	470	R16, R22	Plessey 404/8/02857/MP
20-2681	Metal Oxide	$\frac{1}{4}$	5	680	R17, R21	Erie MO4
20-0151	Composition	1/10	10	150	R20, R27	Erie 15
20-2471	Metal Oxide	$\frac{1}{4}$	5	470	R24	Erie MO4
20-0122	Composition	1/10	10	1.2k	R28	Erie 15

Capacitors

21-4515	Polyester	250V	20	0.22 μ	C2	Radio Resistor POM.A
21-1616	Ceramic	12V	10	0.1 μ	C4, C5, C7-C9 incl., C11, C14, C15,	Murata DD.600.BC.12
21-1002	Tantalum	20V	20	10 μ	C12	Union Carbide K10E20

Diodes

22-1651	Bridge Rectifier	600V	2A		D1	Waycom VS.648
22-1650	Bridge Rectifier	200V			D2, D4, D6, D9	Waycom VS.248
22-1810	Voltage Reg.	400mW	5	6.2V	D3, D7, D10	Mullard BZY88-C6V2

Cct. Ref.	Description	Rat	Tol. %	Value	Component References	Manufacturer
<u>19-0433 (continued)</u>						
<u>Transistors</u>						
22-6017	Silicon npn (High speed)				Q4,Q7,Q10	Motorola 2N.2369
22-6041	Silicon npn (Low level)				Q1,Q3,Q8,Q11 Q13	Mullard BC109 S. G. S. BFY 51
22-6044	Silicon npn				Q5	
23-0013	Fuseholder				FS1-FS5 incl	Bulgin F267/PC

STANDARD READOUT ASSEMBLY (LATCHED) 19-0450

<u>Resistors</u>						
			watts			
20-0181	Composition	1/10	10	180	R2,R3,R4,R6	Erie 15
20-0222	Composition	1/10	10	2.2k	R5,R7,R8,R11, R12.	Erie 15
20-0562	Composition	1/10	10	5.6k	R1,R9,R10,R13, R14,R15,R16	Erie 15
20-0100	Composition	1/10	10	10	R17	Erie 15
20-2393	Metal Oxide	$\frac{1}{4}$	5	39k	R20	Erie MO4
<u>Capacitors</u>						
21-1551	Ceramic	30V	+50-25	0.1 μ	C1	Erie 811/T/30V
<u>Diodes</u>						
22-1029	Silicon				D1	I.T.T. IN 4149
<u>Integrated Circuits</u>						
22-4044	Quad 2 input Pos. Nand Gate				IC1	Motorola 7400
22-4049	B. C. Decade Count				IC3	Motorola 7490
22-4051	Quad Latch				IC2	Motorola 7490
<u>Transistors</u>						
22-6041	Silicon npn				Q2	Mullard BC 109
22-6057	Silicon npn Nixie Driver				Q3-Q12 incl.	Ferranti ZTX 342
<u>Indicators</u>						
26-1013	Tube, Numerical Indicator (Nixie)					Hivac XN13
26-3003	Lamp, D.P.		4.5V	.06A		Vitality 670U/C

Cct. Ref.	Description	Rat	Tol. %	Value	Component References	Manufacturer
--------------	-------------	-----	-----------	-------	-------------------------	--------------

HIGH SPEED DECADE ASSEMBLY 19-0460

<u>Resistors</u>		watts				
20-0101	Composition	1/10	10	100	R27	Erie 15
20-0102	Composition	1/10	10	1k	R36	Erie 15
20-0152	Composition	1/10	10	1.5k	R22, R24	Erie 15
20-0181	Composition	1/10	10	180	R4, R13, R15, R17	Erie 15
20-0221	Composition	1/10	10	220	R19, R34, R37	Erie 15
20-0222	Composition	1/10	10	2.2k	R2, R5, R6, R10, R18, R20, R26	Erie 15
20-0272	Composition	1/10	10	2.7k	R28	Erie 15
20-0331	Composition	1/10	10	330	R29	Erie 15
20-0471	Composition	1/10	10	470	R30, R33	Erie 15
20-0561	Composition	1/10	10	560	R23	Erie 15
20-0562	Composition	1/10	10	5.6k	R1, R3, R7, R8, R12, R14, R16, R31, R32	Erie 15
20-2221	Metal Oxide	$\frac{1}{4}$	5	220	R21, R25, R35	Erie MO4
20-2393	Metal Oxide	$\frac{1}{4}$	5	39k	R11	Erie MO4
<u>Capacitors</u>						
21-1508	Ceramic		10	10p	C1, C6	Erie 831-N.P.O.
21-1512	Ceramic		10	22p	C3, C5	Erie 831-N470
21-1616	Ceramic		10	0.1 μ	C2	Murata DD 600 BC12
21-1003	Tantalum	10V		15 μ	C4	Union Carbide K15E10
21-1515	Ceramic		20	39p	C7	Erie 831-N1500
<u>Diodes</u>						
22-0001	Germanium				D2, D3, D4, D5	Hughes HD1870
22-1029	Silicon				D1, D6, D7, D8	I.T.T. IN 4149

Cct. Ref.	Description	Rat	Tol. %	Value	Component References	Manufacturer
<u>19-0460 (continued)</u>						
<u>Transistors</u>						
22-6017	Silicon npn				Q2, Q13, Q16, Q17, Q18, Q19, Q20	Motorola 2N 2369
22-6059	Silicon npn				Q14, Q15	Mullard BFX 89
22-6041	Silicon npn				Q1	Mullard BC 109
22-6057	Silicon npn Nixie Driver				Q3-Q12 incl.	Ferranti ZTX 342
<u>Integrated Circuits</u>						
22-4044	Quad 2 input Pos. Nand Gate				IC1	Motorola 7400
22-4052	Dual 'D' Type Bistable				IC3, IC4	Motorola 7479
22-4051	Quadruple Latch				IC2	Motorola 7475
<u>Indicator Tube</u>						
26-1013						Hivac XN 13
<u>MAINS FILTER 19-0475</u>						
<u>Capacitors</u>						
21-1540	Ceramic	500V	+25	4700p	C1, C2, C3	Erie 811
<u>Inductors</u>						
17-4032	Choke, sub-miniature			250 μ H	L1, L2	Racal Instruments
<u>ATTENUATOR BOARD ASSEMBLY: 19-0620</u>						
<u>Resistors</u>						
		watts				
20-0121	Composition	1/10	10	120	R1, R2	Erie 15
20-0271	Composition	1/10	10	270	R3	Erie 15
20-0820	Composition	1/10	10	82	R4	Erie 15
<u>Capacitors</u>						
21-1624	Ceramic	50V	20	0.1 μ	C1	Erie 8133-203-Z5U
<u>Switch</u>						
23-4060	Sensitivity, slide, 2 c/o				SA	Jeanrenaud 51MP

Cct. Ref.	Description	Rat	Tol. %	Value	Component References	Manufacturer
-----------	-------------	-----	--------	-------	----------------------	--------------

REMOTE CONTROL ASSEMBLY 19-0628 (Option 02)

Resistors

20-0102	Carbon Film	1/10	10	1k	R1-R10 incl.	Mullard CR16
20-0222	Carbon Film	1/10	10	2.2k	R11-R15 incl.	Mullard CR16

Capacitors

21-1616	Ceramic	12V		0.1 μ	C1	Murata DD 600 BC12
---------	---------	-----	--	-----------	----	--------------------

Transistors

22-6017	Silicon npn				Q1-Q6 incl.	Motorola 2N 2369
---------	-------------	--	--	--	-------------	------------------

Integrated Circuits

22-4045	Quad 2 input Pos. Nor Gate				IC1, IC5	Motorola 7402
22-4044	Quad 2 input Pos. Nand Gate				IC3, IC4	Motorola 7400
22-4053	Triple 3 input Pos. Nand Gate				IC2	Motorola 7410

AMPLIFIER DIVIDER ASSEMBLY: 19-0630

Resistors

		watts		ohms		
20-1527	Carbon Film	1/10	5	270	R1	Nutec RKL10
20-1525	Carbon Film	1/10	5	28	R2, R5	Nutec RKL10
20-0820	Composition	1/10	10	82	R3, R4, R36, R49	Erie 15
20-1530	Carbon Film	1/10	5	390	R6, R15	Nutec RKL10
20-1526	Carbon Film	1/10	5	22	R7	Nutec RKL10
20-0821	Composition	1/10	10	820	R8, R17, R35	Erie 15
20-1515	Carbon Film	1/10	5	180	R9, R14	Nutec RKL10
20-1541	Carbon Film	1/10	5	1.8k	R10, R19, R22	Nutec RKL10
20-1542	Carbon Film	1/10	5	4.7k	R11, R20, R23	Nutec RKL10
20-1517	Carbon Film	1/10	5	330	R12, R18, R21	Nutec RKL10
20-1531	Carbon Film	1/10	5	47	R13	Nutec RKL10
20-1529	Carbon Film	1/10	5	33	R16, R30	Nutec RKL10
20-1522	Carbon Film	1/10	5	12	R22, R28	Nutec RKL10
20-7009	Variable	$\frac{3}{4}$		200	R24	Bourns 3009Y-1 (150ppm)
20-1544	Carbon Film	1/10	5	1.2k	R25	Nutec RKL10
20-1514	Carbon Film	1/10	5	100	R26	Nutec RKL10
20-2221	Metal Oxide	$\frac{1}{4}$	5	220	R27	Erie MO4
- -	Composition	1/10	10	15 - 33	R31 [A.O.T.]	Erie 15
20-0102	Composition	1/10	10	1k	R32, R39, R40	Erie 15
20-0471	Composition	1/10	10	470	R33, R41, R43 R46, R47	Erie 15

Cct. Ref.	Description	Rat	Tol. %	Value	Component References	Manufacturer
<u>19-0630 (continued)</u>						
<u>Resistors</u>						
20-0220	Composition	1/10	10	22	R34	Erie 15
20-0153	Composition	1/10	10	15k	R37	Erie 15
20-0391	Composition	1/10	10	390	R38	Erie 15
20-0151	Composition	1/10	10	150	R42	Erie 15
20-2471	Metal Oxide	$\frac{1}{4}$	5	470	R44	Erie MO4
20-2392	Metal Oxide	1/10	5	3.9k	R45	Erie MO4
20-0100	Composition	1/10	10	10	R48	Erie 15
<u>Capacitors</u>						
21-1709	Ceramic (Monobloc)	100V	-20 +80	.01 μ	C1, C5, C7, C11, C15, C19, C20, C22, C23, C24, C25, C28, C30, C35, C36	Erie 8123-000-Z5U
21-1626	Ceramic	100V	20	.01 μ	C2, C6, C10, C12, C13, C14, C16, C18	Erie CMC-1A-Z5U
21-6004	Variable			3.5/13p	C3, C8	Steatite 7S. Triko-02
— —	Ceramic		10	10-22p	C17 [A. O. T.]	Erie 831
21-302	Ceramic		10	22p	C21	Erie 8000-006-0220 C17
21-1616	Ceramic			0.1 μ	C26, C27, C31, C34,	Murata DD.600.BC12
21-1000	Tantalum	15V	20	3.3 μ	C32, C33	Union Carbide K3R3.E15
<u>Diodes</u>						
22-1809	Voltage Reg.	5.6V			D1	Mullard BZY88-C5V6
22-2003	Tunnel				D2	R.C.A.40573
<u>Transistors</u>						
22-6039	Silicon: npn				Q1, Q2, Q3, Q4, Q6, Q7,	Mullard BFY90
22-6058	Silicon: pnp				Q5	Transitron TES014
22-6017	Silicon: npn: 2N2369				Q8, Q9, Q10	Various
<u>Integrated Circuit</u>						
22-4500	Divide-by-Ten				IC1	Racal Instruments

Cct. Ref.	Description	Rat	Tol. %	Value	Component References	Manufacturer
-----------	-------------	-----	--------	-------	----------------------	--------------

19-0630 (continued)

Miscellaneous

23-8000	Ferrite Bead				X1, X2, X3	Mullard FX1242
23-3126	P.C.B. mounted receptacle:			50-Ω	SKT1	Sealectro Conhex 52/051/0000

MOTHERBOARD ASSEMBLY 19-0634

Resistors watts

20-2471	Carbon Film	$\frac{1}{3}$	5	470	R1, R3, R5, R7	Mullard CR25
20-2181	Carbon Film	$\frac{1}{3}$	5	180	R2, R4, R6, R8, R13, R14, R15, R16, R20, R21	Mullard CR25
20-2821	Carbon Film	$\frac{1}{3}$	5	820	R10, R11, R12	Mullard CR25
20-2391	Carbon Film	$\frac{1}{3}$	5	390	R17	Mullard CR25
20-2681	Carbon Film	$\frac{1}{3}$	5	680	R18	Mullard CR25
20-2103	Carbon Film	$\frac{1}{3}$	5	10k	R19	Mullard CR25
20-2221	Carbon Film	$\frac{1}{3}$	5	220	R22	Mullard CR25
20-2472	Carbon Film	$\frac{1}{3}$	5	4.7k	R23	Mullard CR25
20-2102	Carbon Film	$\frac{1}{3}$	5	1k	R24	Mullard CR25

Capacitors

21-1510	Ceramic		10	15p	C1	Erie 831 N150
21-1528	Ceramic		10	470p	C2	Erie 831 K120051
21-1616	Ceramic	12V	10	0.1μ	C3	Murata DD. 600. BC. 12

Diode

22-1029	Silicon				D1	I.T.T. IN 4149
---------	---------	--	--	--	----	----------------

Solid State Items

22-4044	Integrated Circuit					
	Quad 2 input pos. Nand Gate				IC1	Motorola 7400
22-4047	Integrated Circuit					
	Dual Master-Slave JK Flip-Flop				IC2	Motorola 7473
22-6017	Transistor Silicon npn				Q1, Q2, Q3, Q4, Q5, Q6, Q7	Mullard 2N 2369

Edge Connectors

23-5104	10-way with key				SKT9, SKT10,	} Carr Fastener Permacon
23-5112	18-way with key				SKT11, SKT12, SKT1 to SKT8 incl.	

Cct. Ref.	Description	Rat	Tol. %	Value	Component References	Manufacturer
-----------	-------------	-----	--------	-------	----------------------	--------------

OSCILLATOR P. C. B. ASSEMBLY: 19-0636

<u>Resistors</u>						
		watts	%			
20-2101	Carbon Film	1/3	5	100	R15, R20	Mullard CR25
20-2102	Carbon Film	1/3	5	1k	R25, R26, R27	Mullard CR25
20-2103	Carbon Film	1/3	5	10k	R24	Mullard CR25
20-2122	Carbon Film	1/3	5	1.2k	R10, R16	Mullard CR25
20-2182	Carbon Film	1/3	5	1.8k	R8, R12	Mullard CR25
20-2221	Carbon Film	1/3	5	220	R23	Mullard CR25
20-2222	Carbon Film	1/3	5	2.2k	R13	Mullard CR25
20-2272	Carbon Film	1/3	5	2.7k	R19, R21	Mullard CR25
20-2332	Carbon Film	1/3	5	3.3k	R9, R14	Mullard CR25
20-2391	Carbon Film	1/3	5	390	R30	Mullard CR25
20-2392	Carbon Film	1/3	5	3.9k	R22	Mullard CR25
20-2471	Carbon Film	1/3	5	470	R11, R17, R18	Mullard CR25
20-2560	Carbon Film	1/3	5	56	R28	Mullard CR25
20-2561	Carbon Film	1/3	5	560	R29	Mullard CR25
20-4011	Metal Oxide	1/4	1	470	R31	Electrosil TR4
20-4063	Metal Oxide	1/4	1	330	R32	Electrosil TR4
<u>Capacitors</u>						
21-1003	Tantalum	10V	20	15μ	C3, C11	Union Carbide K15E10
21-1508	Ceramic	25V	-	10p	C12	Erie-Hunt 21103-100-0471-AH-0250
21-1514	Ceramic		10	33p	C7	Erie 831-N1500
21-1532	Ceramic		20	1000p	C4, C9	Erie 931-K350081
21-1616	Ceramic	12V	20	0.1μ	C2, C6, C8, C10	Murata DD. 600. BC.12
21-2552	Silver Mica	350V	5	2200p	C5	Dubilier D20
21-5505	Polycarbonate	100V	20	0.47μ	C1	I.T.T. PMC1RO.47 M100
<u>Diodes and Transistors</u>						
22-1029	Diode, Silicon				D1, D2, D3	I.T.T. 1N4149
22-6017	Transistor Silicon, npn				Q1 to Q6 incl.	Type 2N 2369
22-6044	Transistor Silicon, npn				Q7	S.G.S. BFY51
22-6058	Transistor Silicon pnp				Q8	Transitron TES014
<u>Integrated Circuits</u>						
22-4049	B.C. Decade Counter				IC1	Type 7490
22-4044	Quad 2 input Pos. Nand Gate.				IC2	Type 7400

Cct. Ref.	Description	Rat	Tol. %	Value	Component References	Manufacturer
--------------	-------------	-----	-----------	-------	-------------------------	--------------

OPTIONS PARTS LIST SUMMARY

OPTION 01: DATA OUTPUT ASSEMBLY: 11-0650

10-2137	Cableform Assembly					Racal Instruments
23-3013	Socket: 50-way					Amphenol 57-40500

OPTION 02: DATA OUTPUT AND REMOTE CONTROL

NOTE: Option 02 also includes the items in Option 01 (above).

19-0628	Remote Control, Assembly (see page 7-14)					Racal Instruments
10-2136	Cableform Assembly (Remote Control)					Racal Instruments
23-3010	Socket: 14-way					Amphenol 57-40140

OPTION 04: ALTERNATIVE FREQUENCY STANDARD

842	Fast Warm Up Oscillator: 5MHz					Racal Instruments
-----	-------------------------------	--	--	--	--	-------------------

OPTION 06: EIGHT DIGIT READOUT

An additional Standard Readout Assembly Type 19-0450 is fitted.

- NOTES:
- 1 UNLESS OTHERWISE INDICATED RESISTORS IN OHMS, CAPACITORS IN PICOFARADS
 - 2 CONNECTIONS NUMBER CONSECUTIVELY FROM LEFT TO RIGHT FACING COMPONENT SIDE OR ASSY

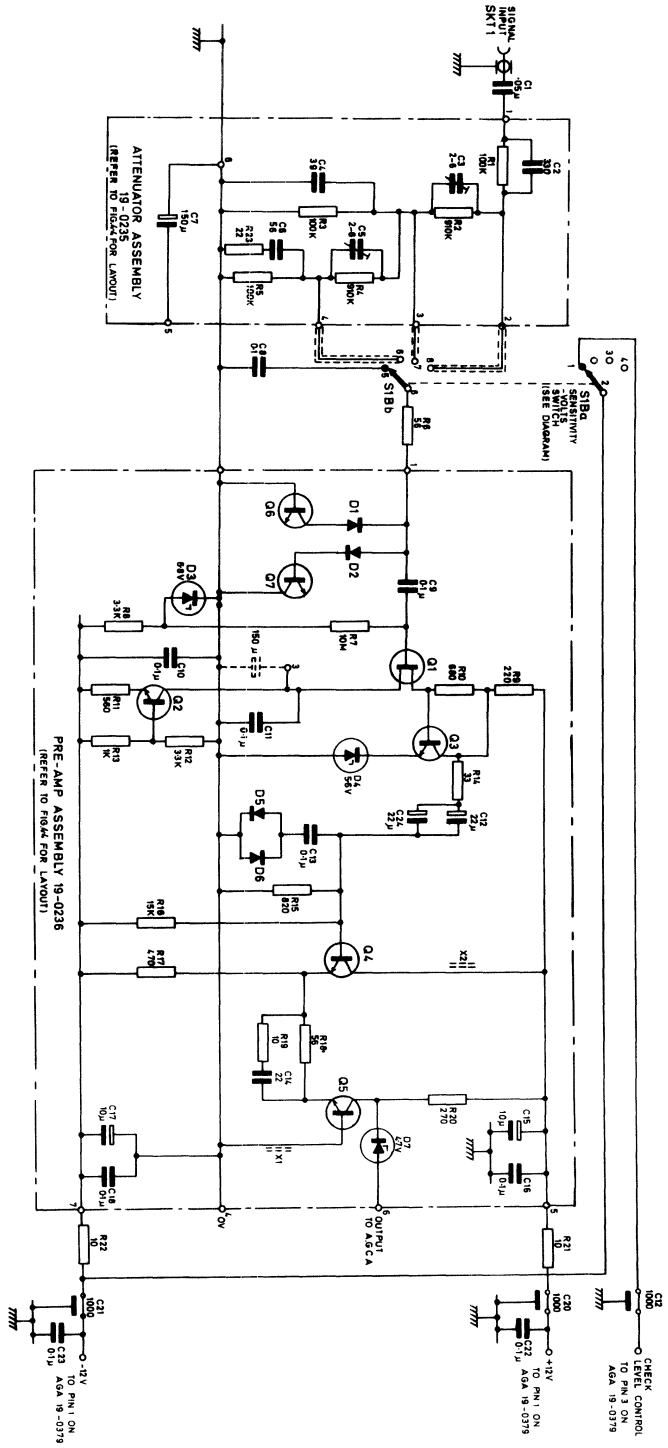
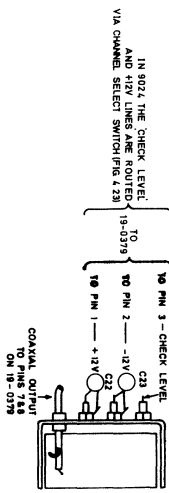
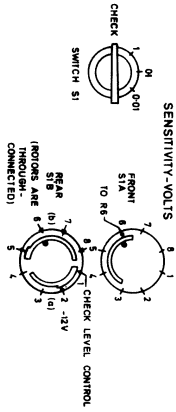

Circuit: Pre-Amplifier Assembly 11-0339

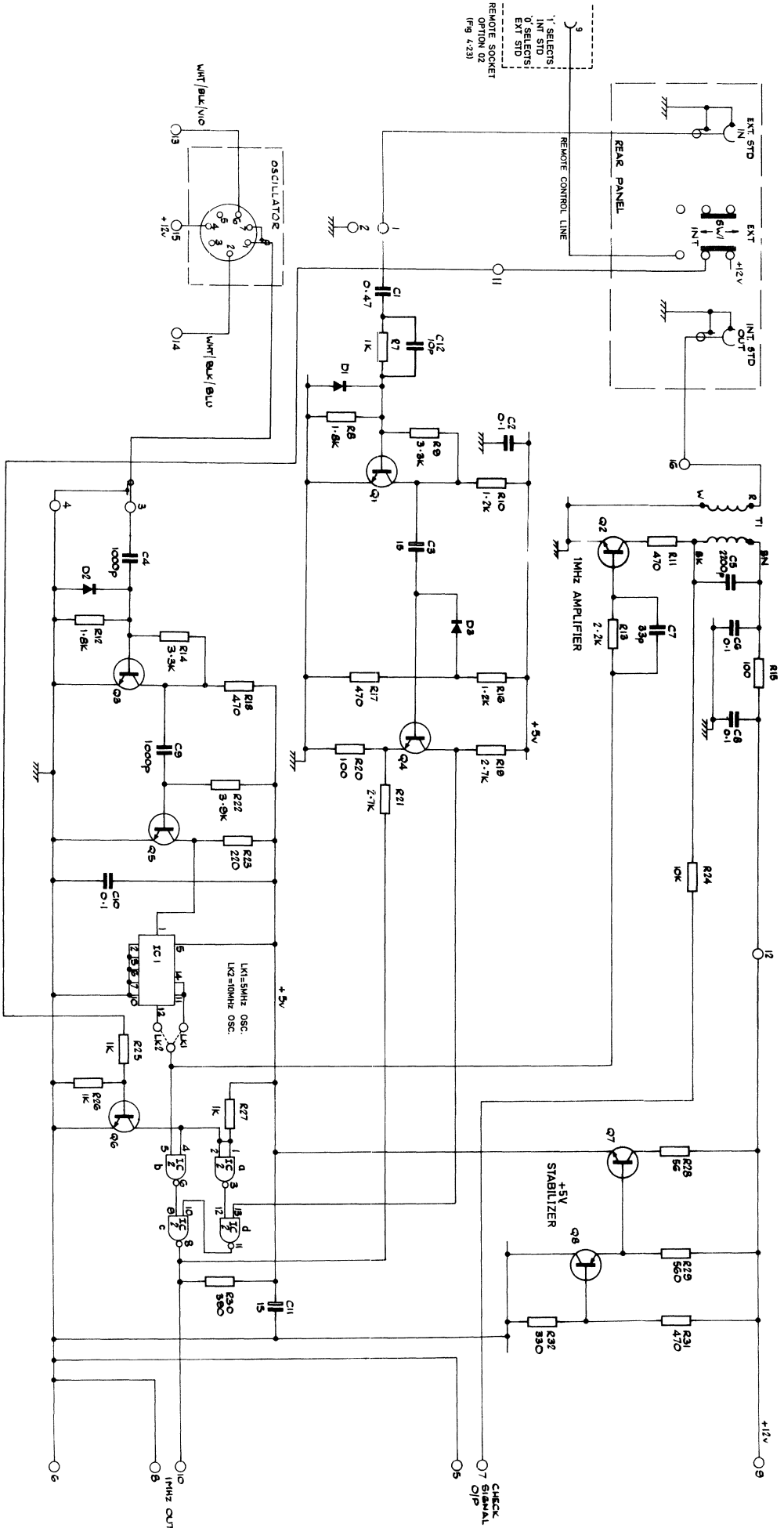

NOTE: 1 FOR PCB LAYOUT REFER TO FIG. 4.12 (19-0636)

Circuit: Frequency Standard Oscillator Assembly 19-0636
(WITH P.C.B. ASSEMBLY 19-0636)

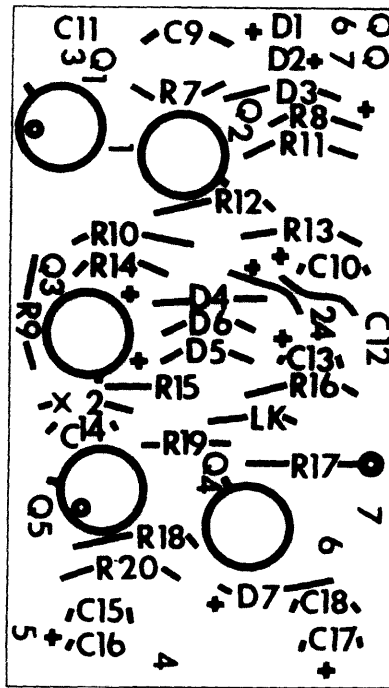

19-0236
2

Pre-Amplifier Board
19-0236

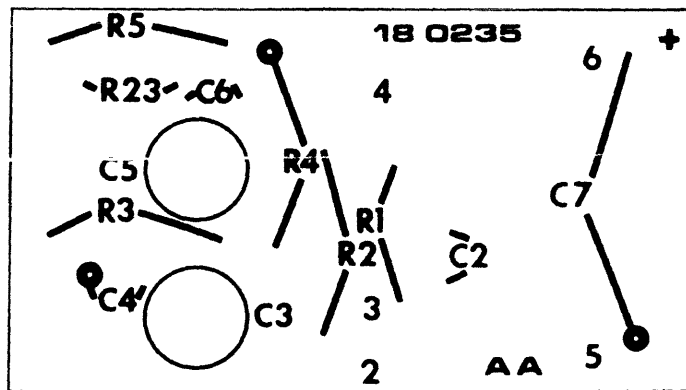

19-0235
2

Attenuator Board
19-0235

WOH 2078

Layout: Attenuator and Pre-Amplifier Assemblies

Fig. 4-4

(PART OF PRE-AMPLIFIER ASSEMBLY 11-0339 Fig 4-1)

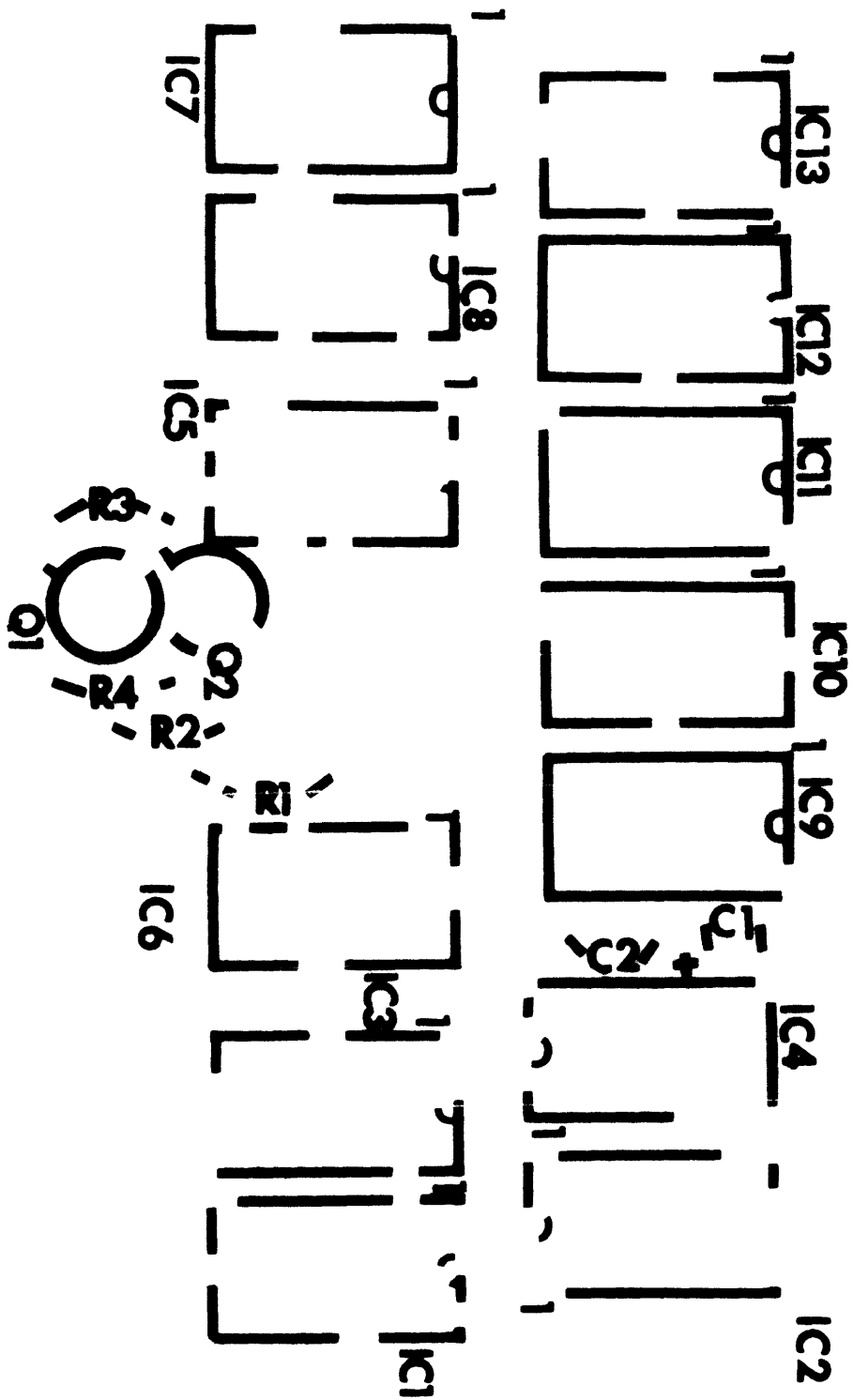

Layout: Time Base Divider Assembly
19-0352

Fig.4·5

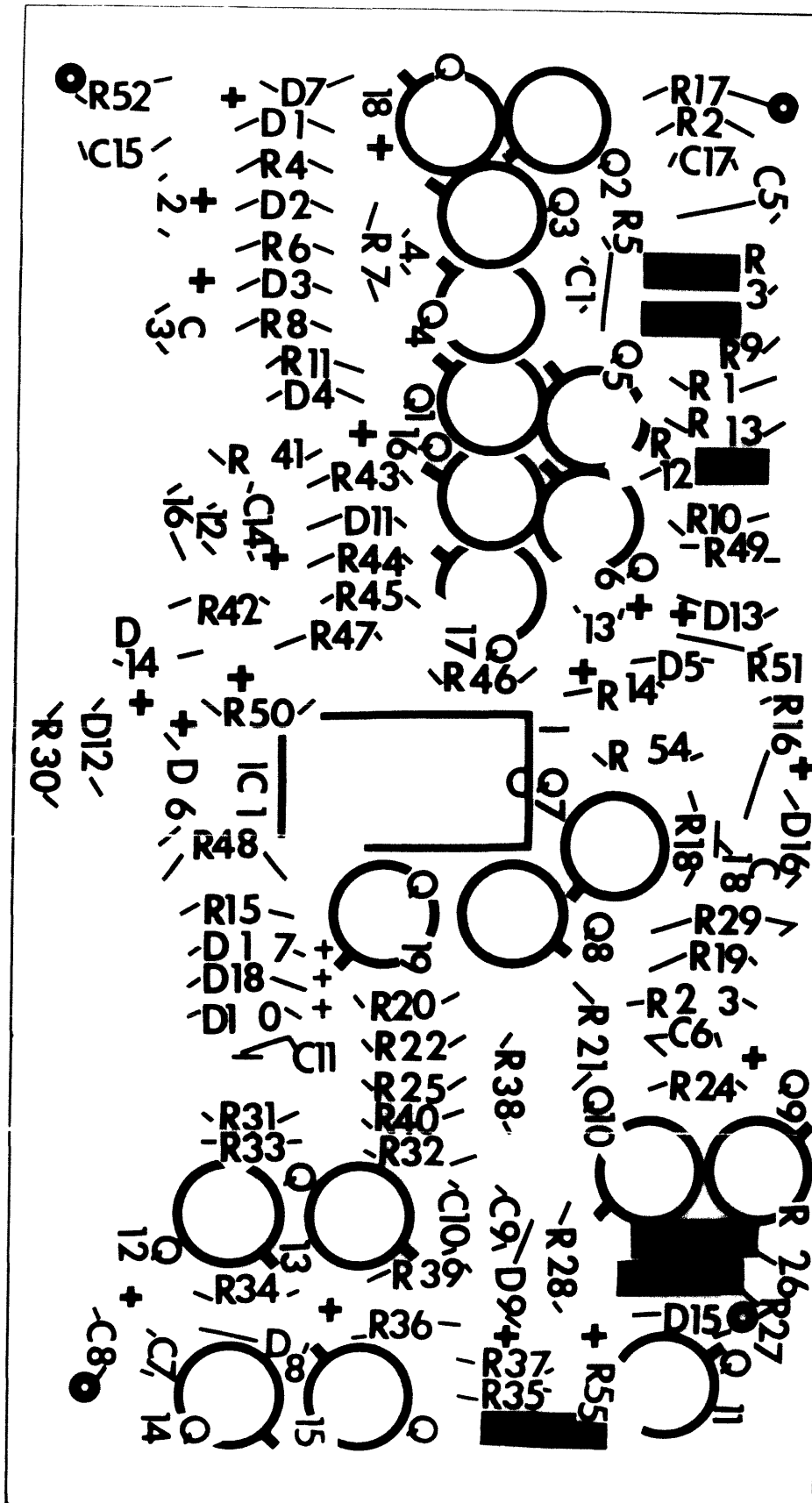

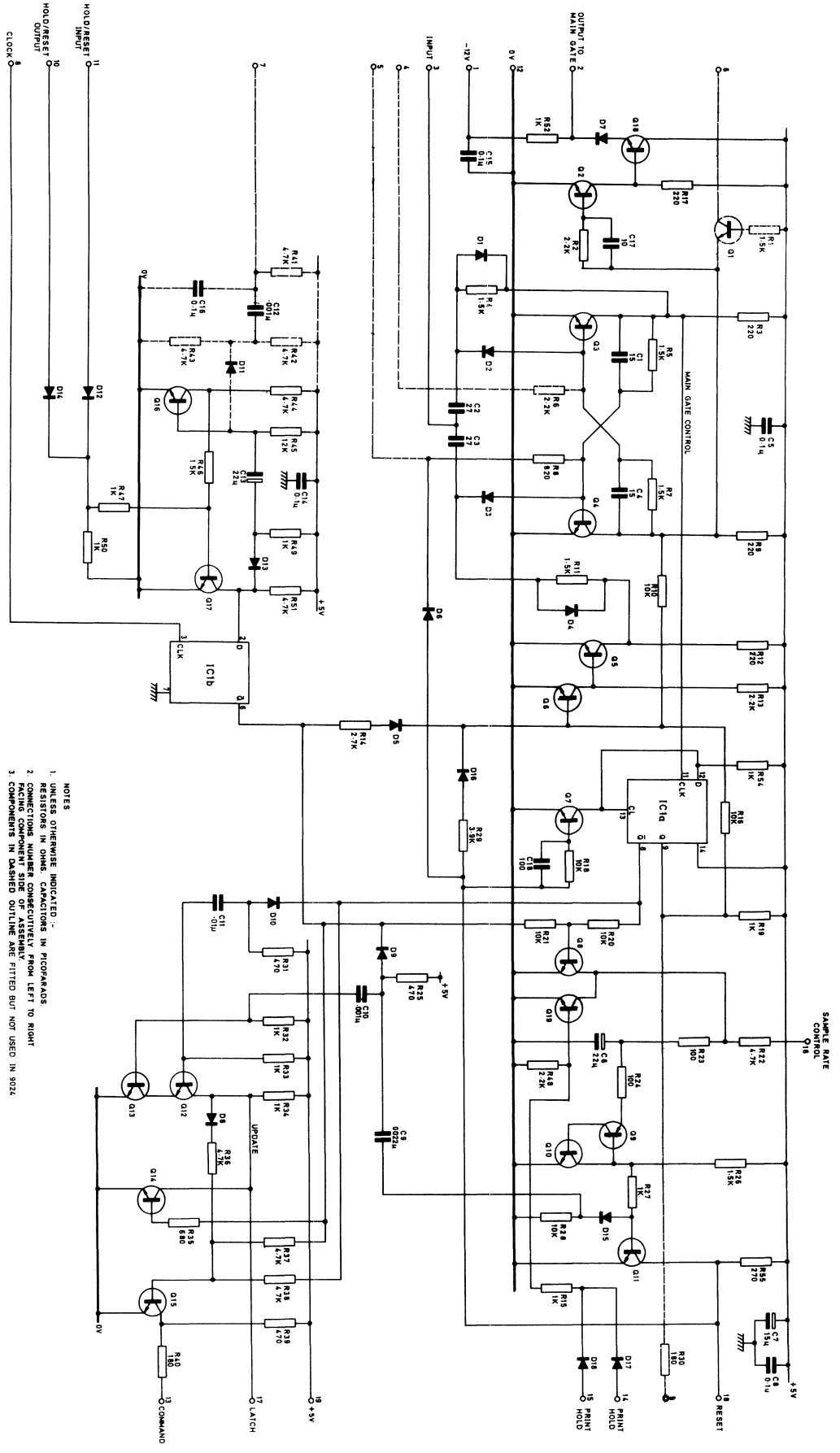

- NOTES
1. UNLESS OTHERWISE INDICATED -
 2. RESISTORS IN OHMS, CAPACITORS IN PICOFARADS
 3. CONNECTIONS NUMBER CONNECTIONS FROM LEFT TO RIGHT
 4. CONNECTIONS NUMBER CONNECTIONS FROM TOP TO BOTTOM
 5. COMPONENTS IN DASHED OUTLINE ARE FITTED BUT NOT USED IN 9074

Circuit : Control Circuit Assembly 19-0356

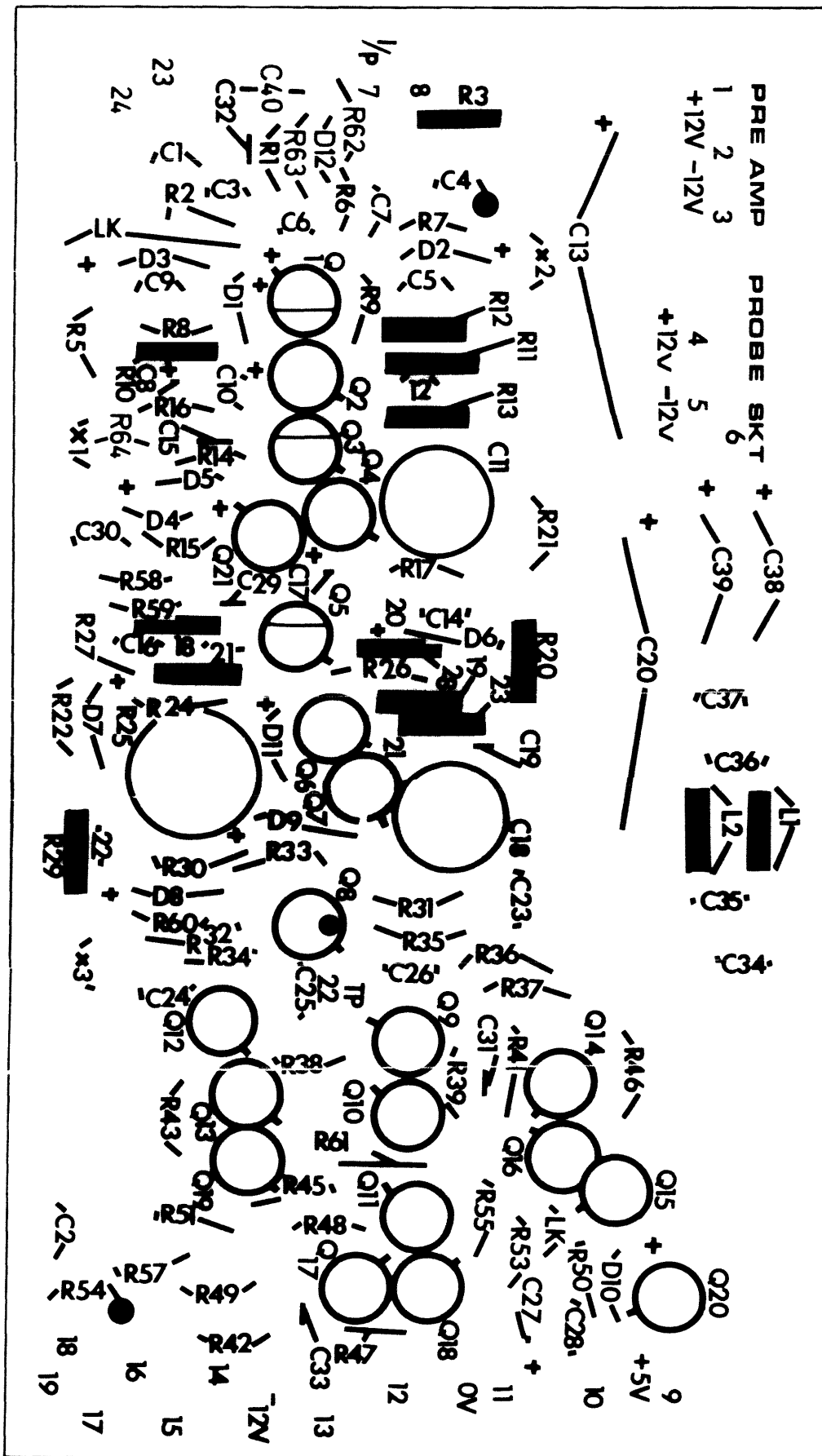

Layout : Amplifier Gating Assembly
19-0379

Fig. 4-9

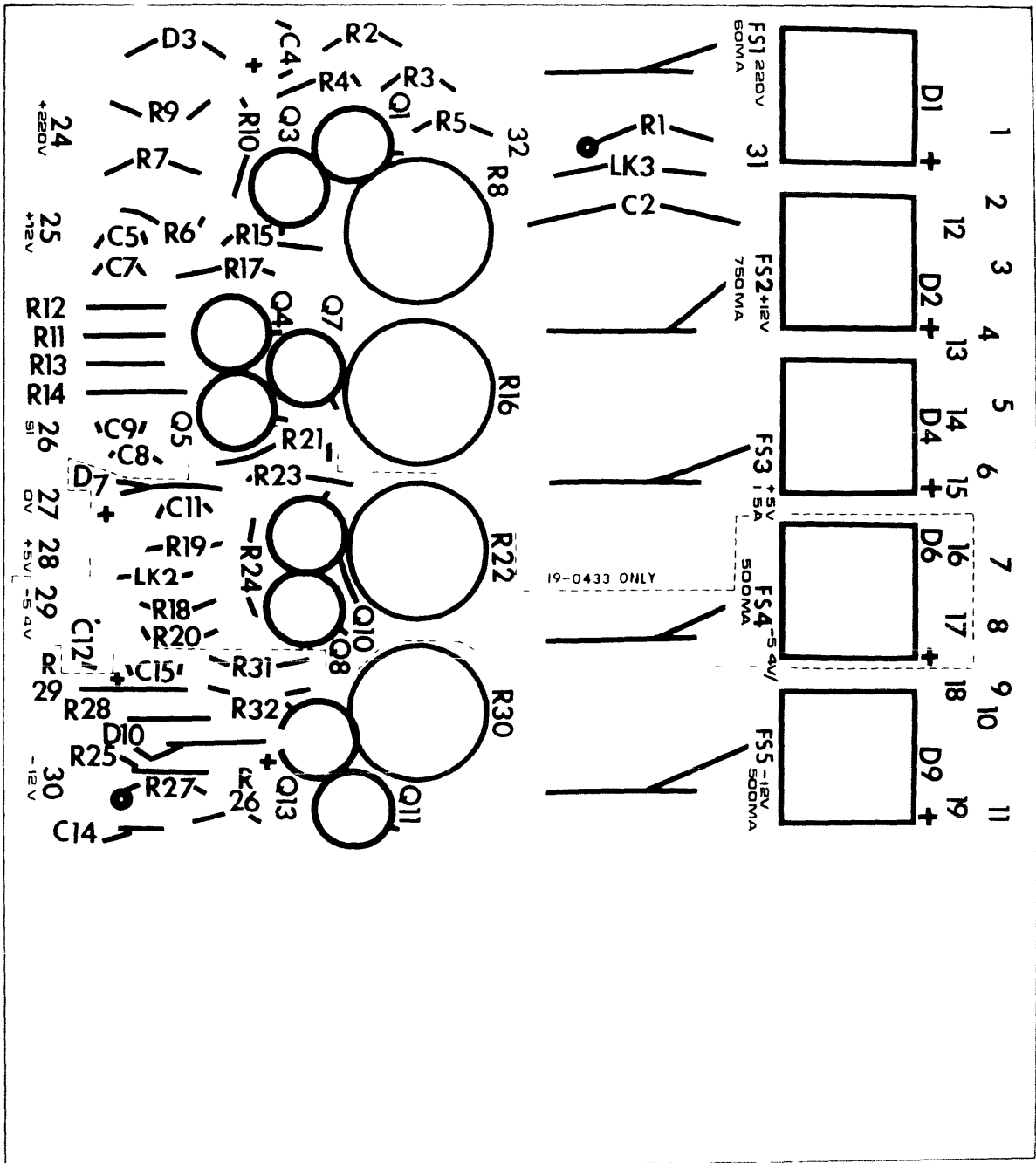

WCH 2078 19 0433
1121

Layout Stabilised Power Supply 19-0433

Fig. 4-11

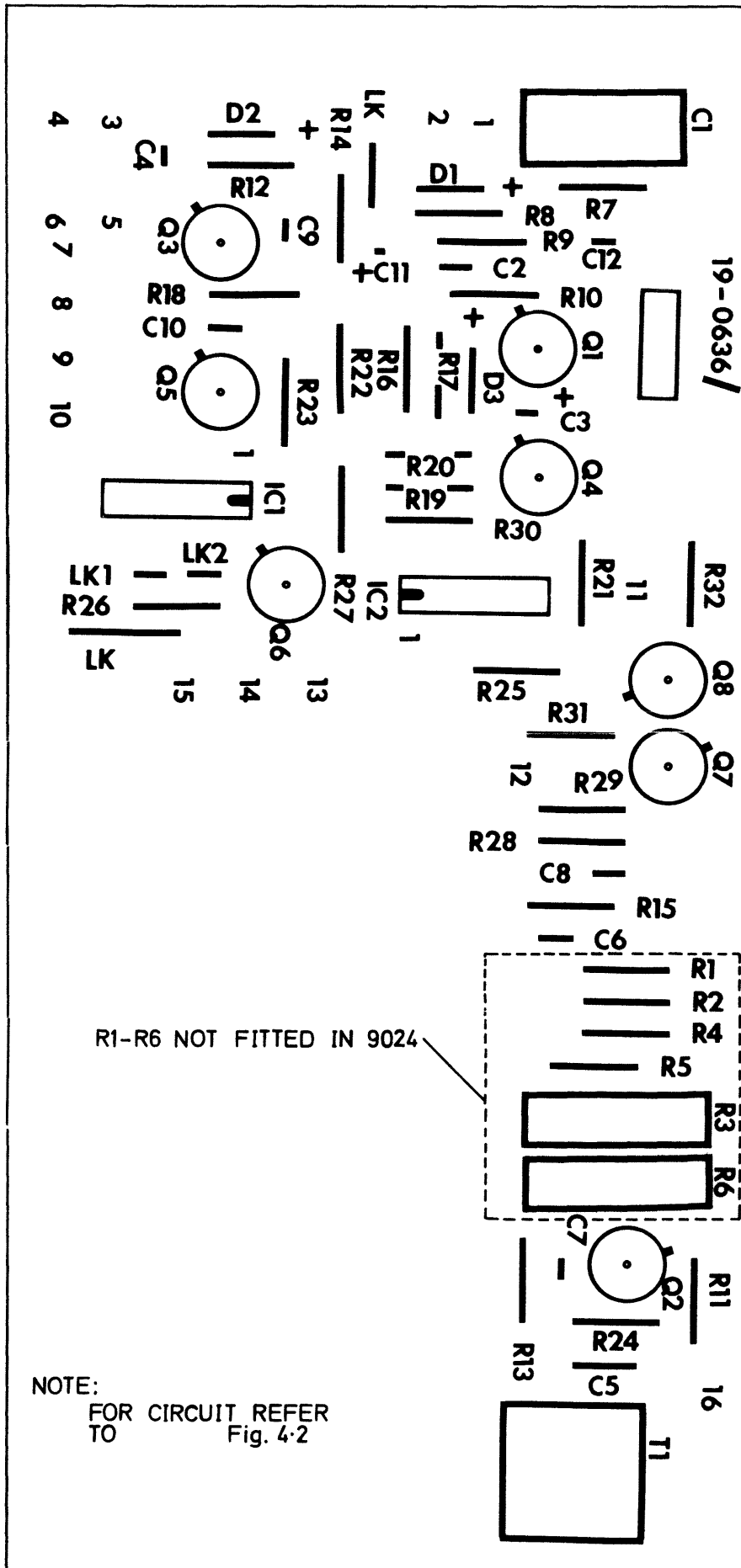

WOH2078	19-0636
1	

Layout: Oscillator P.C.B Assembly
19-0636

Fig. 4-12

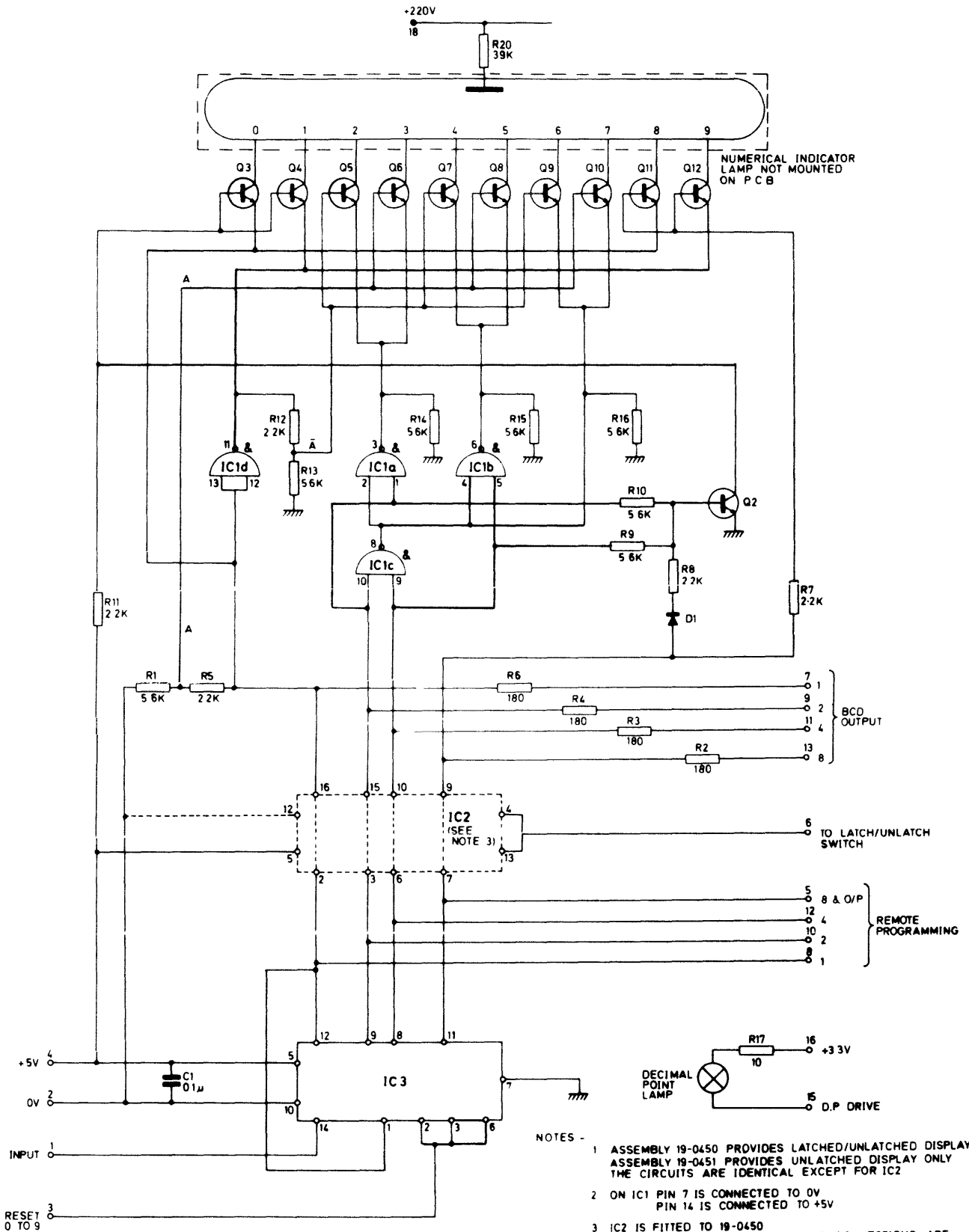

WOH 2078	19-0450/51
1	2

Readout Decade Assemblies Type 19-0450 & 19-0451

(ONLY 19-0450 IS FITTED WITH LATCHED DISPLAY)

Fig. 4-14

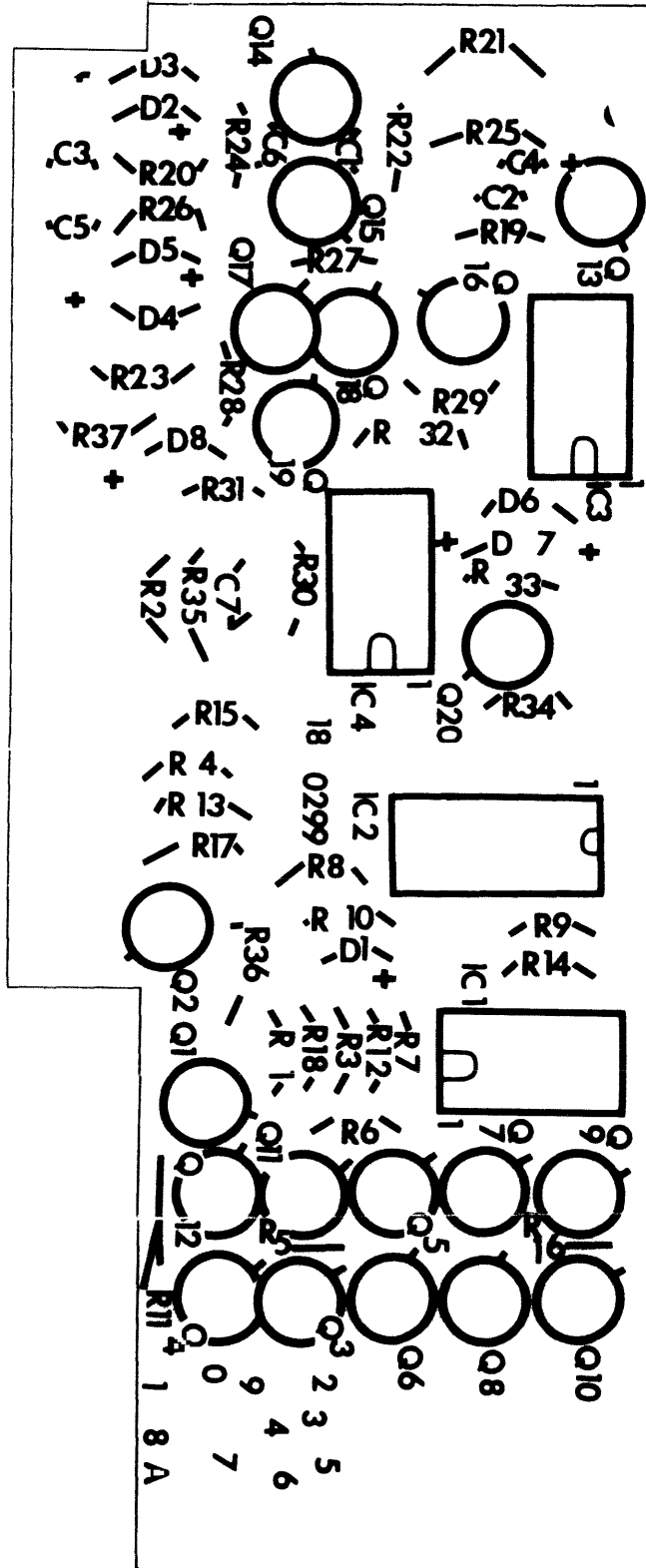

WOH 2078 16-0460
11

Layout : High Speed Decade Assembly
19-0460

Fig.4.15

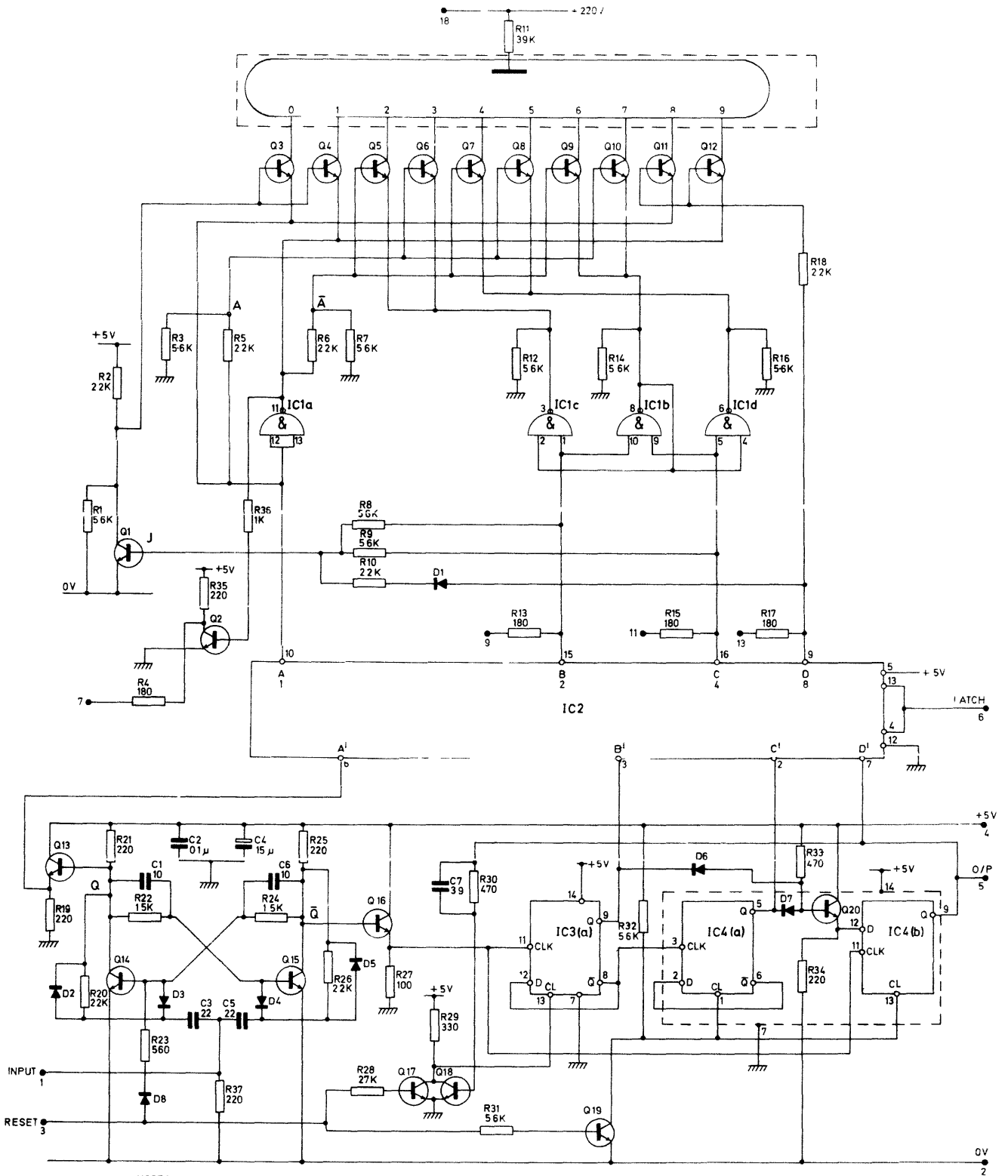

NOTES
 1 UNLESS OTHERWISE INDICATED
 RESISTORS IN OHMS CAPACITORS IN PICOFARADS
 2 CONNECTIONS NUMBER CONSECUTIVELY FROM LEFT
 TO RIGHT FACING COMPONENT SIDE OF ASSY

WOH 2078 19-0460
 1 2 1 3

High Speed Decade 19-0460

Fig. 4.16

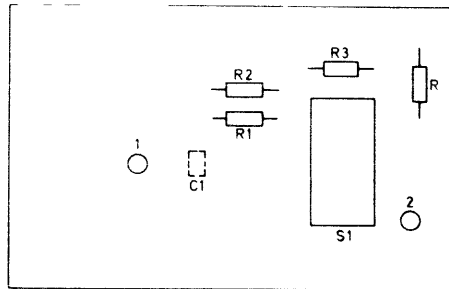

19-0620/1
1

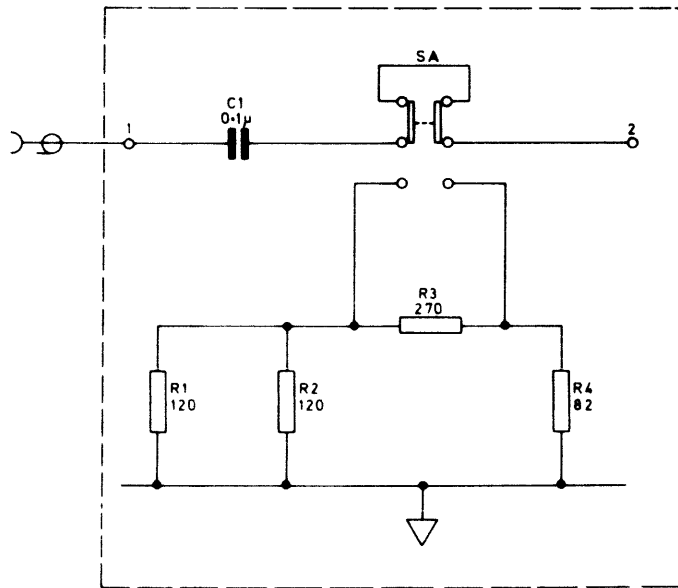

19-0620/2
1

WOH 2078	19-0620
1	

Circuit and Layout
Attenuator Assembly : 19-0620

Fig.4-17

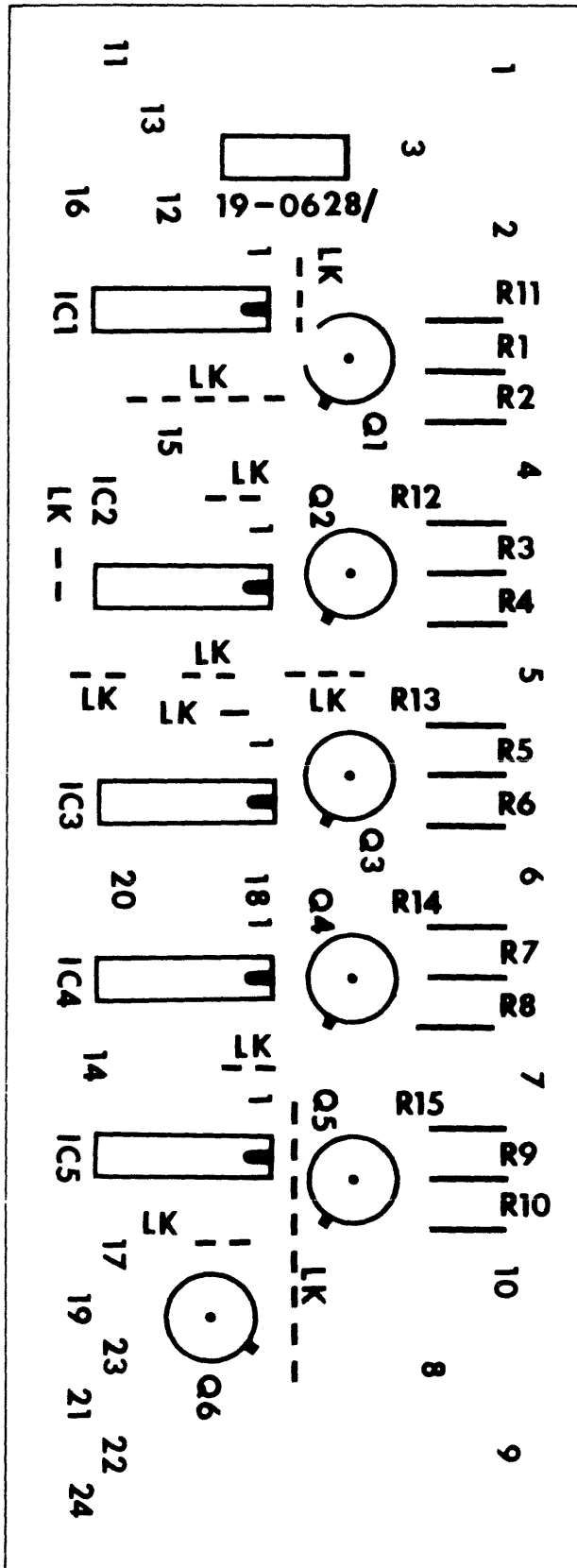

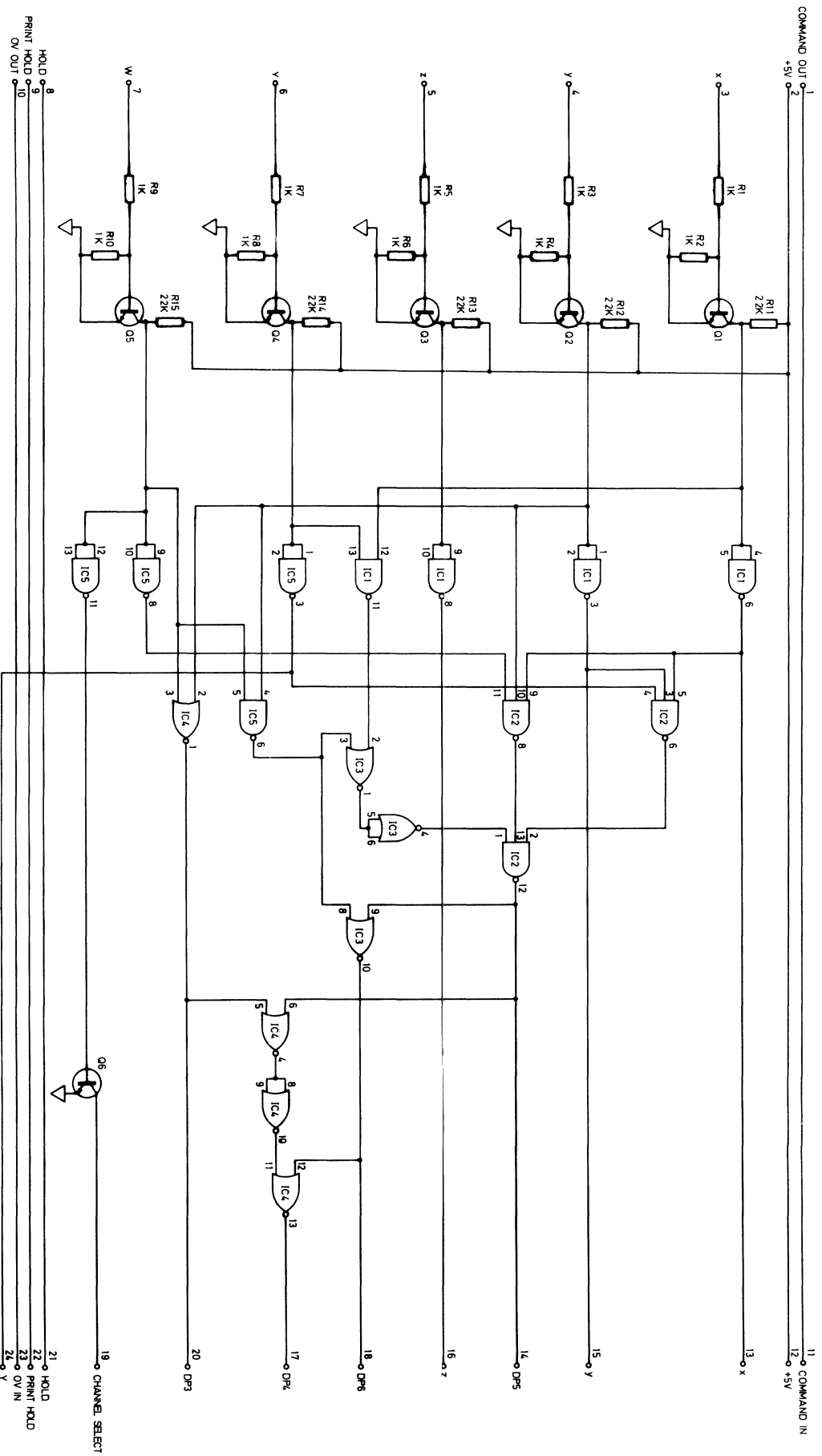

WOH 2078 19-0628

Circuit: Remote Control Assembly 19-0628

Fig. 4-19

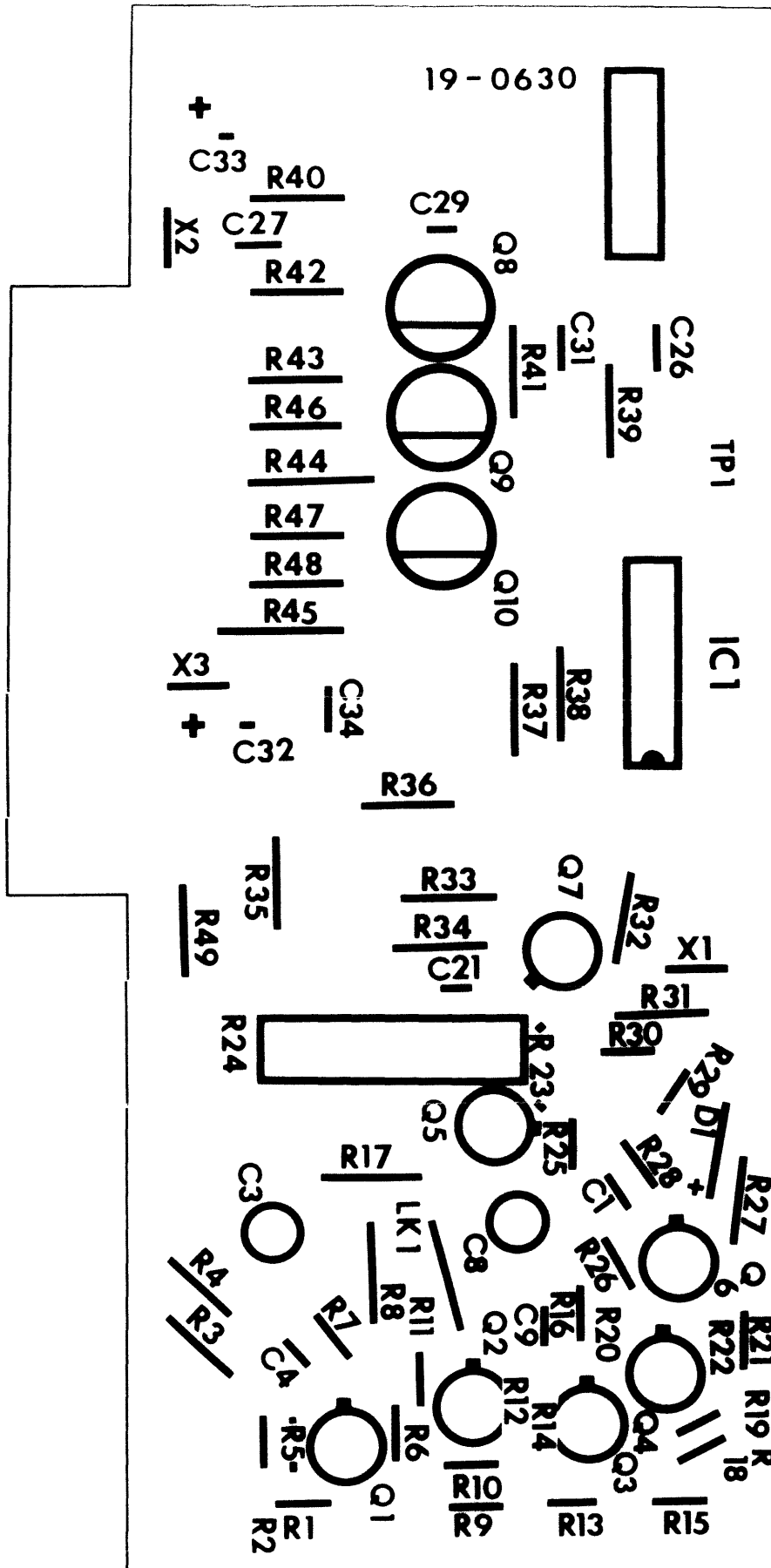

Layout : Amplifier Divider Assembly
19-0630

Circuit: Amplifier Divider Assembly 19-0630

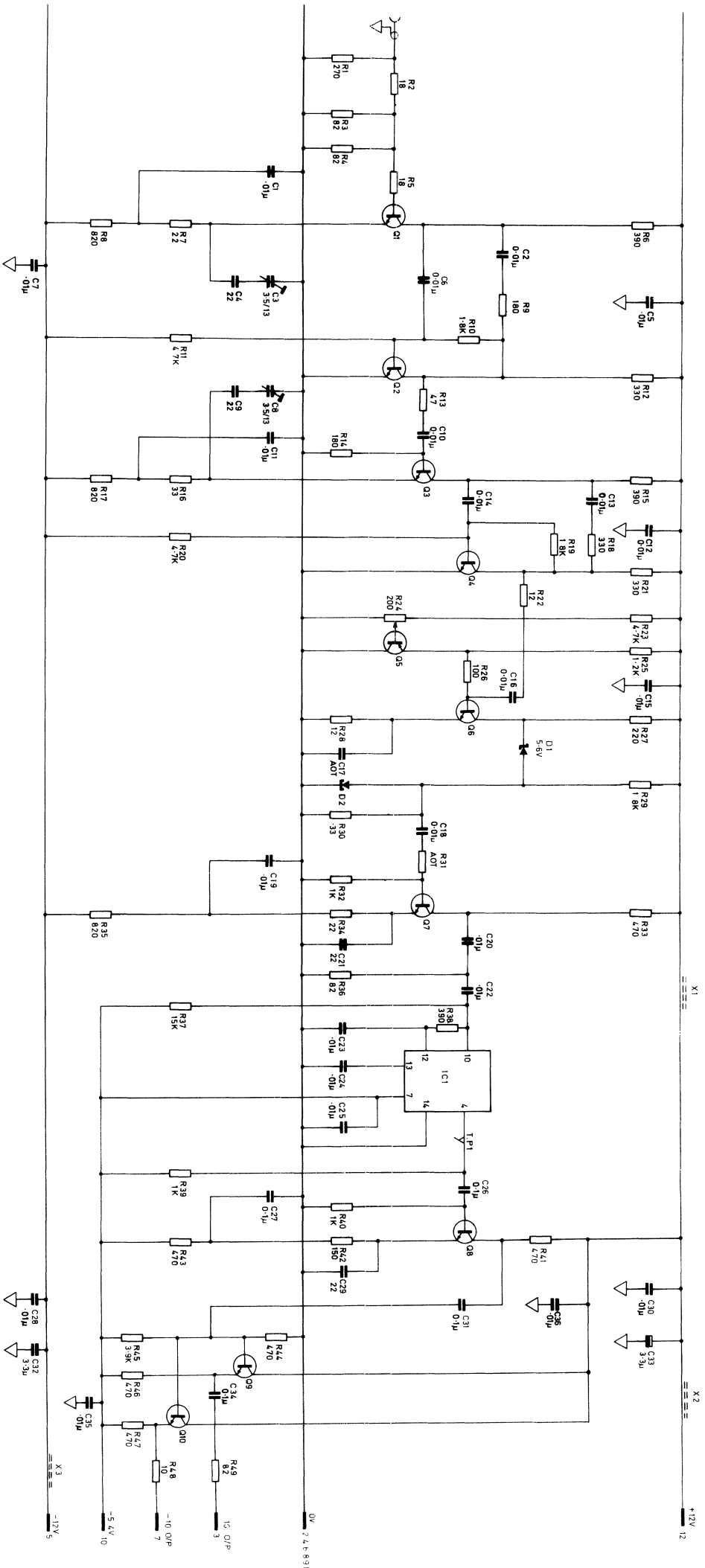

- NOTES:
1. THE VALUES OF C17 AND R31 ARE SELECTED BY TEST FROM THE FOLLOWING RANGES:
C17 --- 15-33p
R31 --- 15-33p
 2. C36 IS FITTED BY TEST

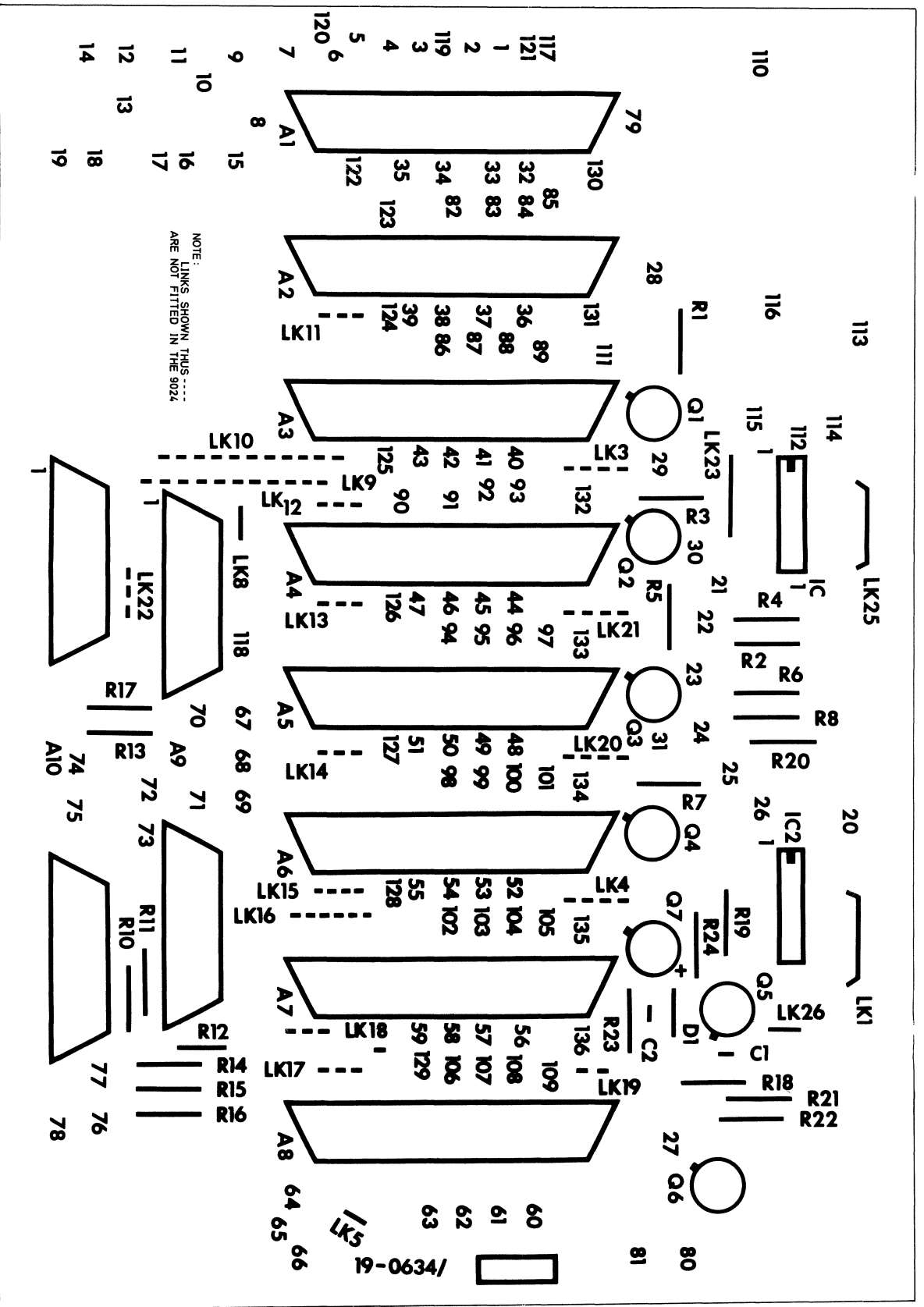

Layout: Motherboard Assembly 19-0634

Fig. 4-22

FREQUENCY PERIOD METER 9024AMENDMENTPower Supply Assembly 11-0565 (Fig. 4.3)

In some models, on the Stabilizer P.C.B. 19-0433, R14 has a value and connection details different from those given in the handbook. Also Q5 differs in type.

If R14 is found on inspection to have a value of 56 ohm then its circuit connection is between Q5 collector and the +12V rail to pin 26. The Part Number of the resistor is 20-2560. Also, with the 56 ohm resistor the correct transistor for Q5 is a type 2N2369 (Part No. 22-6017).

If R14 has a value of 10 ohm, then the connection details are as shown in the handbook and Q5 will be a type BFY51 (Part No. 22-6044) as listed on page 7.11.

A P P E N D I X 1

O P T I O N 01: D A T A (B, C, D.) O U T P U T

For the logic details of Option 01 reference should be made to Page 7 of the Technical Specification at the front of the handbook. The interconnection details are given in Fig.4.23, from which it is seen that in addition to the display data, information is also available from the time base and function selection. The provision of overflow and decimal point information is also included in this comprehensive data readout.

The Data Output Assembly Type 11-0650 consists of a cableform with a 50-way socket for which provision is made by an aperture on the rear panel. See page 7-18 for parts details.

A P P E N D I X 2

O P T I O N 02: R E M O T E C O N T R O L A N D D A T A O U T P U T

This Option comprises the following items:-

- (a) Data Output Assembly 11-0650 (see Option 01).
 - (b) Remote Control P.C.B. Assembly 19-0628 (Fig.4.19).
 - (c) Relay RLA
 - (d) Diode D4
 - (e) Remote Control Outlet Socket.
- } (Fig. 4. 23)

The wiring details are given in the lower right hand corner of Fig.4.23, in addition to which, note that three links are removed when fitting this option, they are:-

- (a) From the Function switch between wafer 1 Tag 12 and wafer 5 Tag 1.
- (b) From the Function switch between wafer 3 tag 8 and wafer 6 tag 12.
- (c) The link which normally completes the loop now provided by contact RLAI of the relay.

OPTION 02 (continued)

For logic details refer to pages 8 and 9 of the Technical Specification at the front of the handbook.

Remote Control P.C.B. Assembly 19-0628

The circuit of this assembly is shown in Fig.4.19 and the location in Fig.2.7. Referring to Fig.4.19 it is seen that the board contains a number of "interface" transistors (Q1 to Q5) and a gating network IC1 to IC5. The function of transistors Q1 to Q5 is to render it unnecessary for the customer's logic levels to match those of the instrument, '0' levels down to -20V and '1' levels to +10V being acceptable.

Remote Programming of Frequency Standard

Refer to Technical Specification page 9 for logic data and to Chapter 5 para 5.17 for technical description. Circuit details are shown in Fig. 4.2 The only part of Option 02 which is necessary for this facility is the 14-way outlet socket via which the control logic may be applied.

A P P E N D I X 3

O P T I O N 04: A L T E R N A T I V E T Y P E O F F R E Q U E N C Y

S T A N D A R D

The technical details of Option 04 Alternative Frequency Standard (Racal Type 9420) refer to para.1.5 of the Technical Specification at the front of the handbook. The oscillator plugs into the B7G valve base on the Oscillator p.c.b. Assembly and no circuit changes are necessary other than to check that the link LK1 or LK2 on the oscillator P.C.B. is correctly connected (Refer to Section 2, Chapter 5, para.5.18).

A P P E N D I X 4

O P T I O N 06: E I G H T D I G I T R E A D O U T

Option 06 Eight Digit Readout requires the fitting of an additional Standard Readout Assembly 19-0450 (For technical details refer to Section 2, Chapter 5, Para. 5.48). The Standard Readout Assembly plugs into the vacant edge connector socket on the Mother-board. (See Service View, Fig.2.7). The link LK6 must replace Link LK5 on the Mother-board Assembly as shown on Fig. 4.23.

