

★  
T. O. 12R2-2URC4-2

HANDBOOK  
MAINTENANCE INSTRUCTIONS

**RADIO SET**  
AN/URC-4

**REVISION**  
NOTICE

**LATEST REVISED PAGES SUPERSEDE  
THE SAME PAGES OF PREVIOUS DATE**

Insert revised pages into basic  
publication. Destroy superseded pages.

PUBLISHED UNDER AUTHORITY OF THE SECRETARY OF THE AIR FORCE

Reproduction for non-military use of the information or illustrations contained in this publication is not permitted without specific approval of the issuing service (BuAer or USAF). The policy for use of Classified Publications is established for the Air Force in AFR 205-1 and for the Navy in Navy Regulations, Article 1509.

**LIST OF REVISED PAGES ISSUED**

**INSERT LATEST REVISED PAGES. DESTROY SUPERSEDED PAGES.**

NOTE: The portion of the text affected by the current revision is indicated by a vertical line in the outer margins of the page.

Page No.	Date of Latest Revision
i . . . . .	1 July 1952
1 . . . . .	21 December 1953
2 . . . . .	21 December 1953
2A . . . . .	20 August 1956
3 . . . . .	1 July 1953
5 . . . . .	1 July 1952
6 . . . . .	1 July 1952
7 . . . . .	1 July 1952
8 . . . . .	1 July 1952
9 . . . . .	1 March 1951
11 . . . . .	15 October 1958
12 . . . . .	15 October 1958
12A . . . . .	1 July 1952
15 . . . . .	1 July 1952
16 . . . . .	1 July 1952
17 . . . . .	1 July 1952
*18 . . . . .	5 May 1960
19 . . . . .	1 July 1952
21 . . . . .	1 July 1952
22 . . . . .	1 July 1952
23 . . . . .	1 July 1952
24 . . . . .	1 July 1952
25 . . . . .	1 July 1952
26 . . . . .	1 July 1952

\* The asterisk indicates pages revised, added or deleted by the current revision.

**ADDITIONAL COPIES OF THIS PUBLICATION MAY BE OBTAINED AS FOLLOWS:**

USAF ACTIVITIES.—In accordance with Technical Order No. 00-5-2.

USAF

NAVY ACTIVITIES.—Submit request to nearest supply point listed below, using form NavAer-140; NASD, Philadelphia, Pa.; NAS, Alameda, Calif.; NAS, Jacksonville, Fla.; NAS, Norfolk, Va.; NAS, San Diego, Calif.; NAS, Seattle, Wash.; ASD, NSC, Guam.

For listing of available material and details of distribution see Naval Aeronautics Publications Index NavAer 00-500.

Revised 5 May 1960

## TABLE OF CONTENTS

Section		Page No.
I	INTRODUCTION . . . . .	1
	1-1. General Description . . . . .	1
II	TABLE OF SPECIFICATIONS . . . . .	2
	2-1. General . . . . .	2
	2-3. Amplitude-Modulated Voice Transmitter . . . . .	2
	2-4. Tone-Modulated Transmitter . . . . .	2
	2-5. Super-Regenerative Receiver . . . . .	2
	2-6. Tube Complement . . . . .	2
	2-7. Fuse Complement . . . . .	2A
	2-8. Frequency Ranges . . . . .	2A
	2-9. Output Characteristics . . . . .	2A
	2-10. Operating Voltages and Currents . . . . .	2A
III	THEORY OF OPERATION . . . . .	3
	3-1. General . . . . .	3
	3-3. General System Operation . . . . .	3
	3-5. Transmission, Voice . . . . .	4
	3-6. Radio Frequency Generating Circuits . . . . .	4
	3-7. Speech Amplifier and Modulator Stages . . . . .	4
	3-8. Transmission, Tone. . . . .	4
	3-9. Tone Generator. . . . .	5
	3-10. Speech Amplifier Stage . . . . .	5
	3-11. Side Tone . . . . .	5
	3-12. Receiving . . . . .	5
	3-13. Detector Circuits . . . . .	5
	3-14. Audio Amplifier Stages . . . . .	5
	3-15. Functional Operation of Electronic Components . . . . .	5
	3-16. Functional Operation During Transmission . . . . .	5
	3-17. Crystal Oscillator Stage . . . . .	5
	3-18. First Doubler Stage . . . . .	5
	3-19. Second Doubler and VHF Output Stage . . . . .	6
	3-20. Third Doubler and UHF Output Stage . . . . .	6
	3-21. Antenna . . . . .	7
	3-22. Speech Amplifier and Modulator Circuits . . . . .	7
	3-27. Functional Operation During Tone Modulation . . . . .	8
	3-29. Functional Operation During Reception . . . . .	8
	3-30. UHF and VHF Detectors . . . . .	8
	3-34. First Audio Amplifier Stage . . . . .	9
	3-35. Second Audio Amplifier Stage . . . . .	10
	3-37. Antenna . . . . .	10
IV	TEST EQUIPMENT AND SPECIAL TOOLS . . . . .	10
	4-1. Test Equipment . . . . .	10
V	TROUBLE SHOOTING, REPAIR AND OVERHAUL . . . . .	11
	5-1. General . . . . .	11
	5-3. Opening the Receiver-Transmitter Case . . . . .	11
	5-4. Removing the Chassis from the Case . . . . .	11
	5-5. Removing and Replacing Tubes . . . . .	12
	5-6. Battery Voltages . . . . .	12
	5-7. Trouble Shooting Charts . . . . .	13
	5-8. Periodic Checks and Preventive Maintenance . . . . .	18
	5-9. Testing Battery . . . . .	18
VI	ALIGNMENT AND TESTING . . . . .	18
	6-1. General . . . . .	18
	6-2. Analyzer TS-684/URM-30 . . . . .	18
	6-3. Emergency Alignment Without Analyzer TS-684/URM-30 . . . . .	18
VII	DIAGRAMS . . . . .	19

TABLE OF CONTENTS



Figure 1-1. Radio Set AN/URC-4, Operating Components

## SECTION I

## INTRODUCTION

## 1-1. GENERAL DESCRIPTION

1-2. Radio Set AN/URC-4 is a compact, lightweight receiving and transmitting equipment designed for use under emergency rescue conditions. The basic operating components (figure 1-1) of the equipment consist of Radio Receiver-Transmitter RT-159/URC-4, RT-159A/URC-4 or RT-159B/URC-4, Battery BA-1264/U and Special Purpose Cable Assembly CX-1093/U. The Special Purpose Cable Assembly is supplied in two lengths, 2 ft. 6 in. and 5 ft. 6 in. Only one cable is required for operation. The length of cable to be supplied with an individual radio set is determined by the conditions of operation. All reference to the RT-159A/URC-4 will also apply to the RT-159B/URC-4 except when otherwise noted.



Figure 1-2. Vest, Radio Carrier AN/URC-4

1-3. The basic components described in paragraph 1-2 will be supplied for all conditions of use and operation. The equipment also consists of a number of variable components which will be supplied in addition to the basic components, when required, for a particular application. The following variable components are part of the Radio Set: Vest, Radio Carrier AN/URC-4, figure 1-2, is supplied when the equipment is to be carried on the person of airmen during flight missions; and Droppable Kit AN/URC-4, figure 1-3, is used in aerial delivery of the radio equipment to survivors of aircraft crashes and forced landings. The Droppable Kit consists of Container, Aerial Delivery, Type A-20, and Parachute, Aerial Delivery, Type G-7 modified.



Figure 1-3. Droppable Kit, AN/URC-4

1-4. The Radio Set is a portable, hand-operated unit designed to furnish two-way voice and keyed-tone communication between distressed personnel and searching aircraft. The transmitter is crystal-controlled, and depending upon the crystal in use, will transmit on any preset frequency within the VHF band of 120 to 130 megacycles, or in the UHF band of 240 to 260 megacycles. The output on any frequency in the UHF band will always be twice the VHF output frequency. The equipment is normally preset to the distress frequencies of 121.5 megacycles and 243 megacycles. The actual frequencies of operation are indicated on the nameplate of the radio receiver-transmitter unit.

1-5. The receivers are of the super-regenerative type and can be tuned independently of the transmitter to any desired frequency within the VHF and UHF bands mentioned in paragraph 1-4. The receivers are normally preset for operation on the same frequencies as the transmitter.

1-6. The equipment is not designed nor intended for general utility use or ground installation. However, in the event of an emergency, the equipment may be used for airdrome traffic control.

1-7. The equipment as supplied to using personnel is completely self-contained. No auxiliary, test, or other equipment is required for operation. Table I lists all the components that comprise Radio Set AN/URC-4.

TABLE I. EQUIPMENT SUPPLIED		
QUANTITY REQUIRED	NAME OF EQUIPMENT	TYPE DESIGNATION
1	Radio Receiver-Transmitter	RT-159/URC-4 RT-159A/URC-4 RT-159B/URC-4
1	Battery	BA-1264/U
1	Special Purpose Cable Assembly	CX-1093/U (2 ft. 6 in.) CX-1093/U (5 ft. 6 in.) CX-1093A/U (2 ft. 6 in.)
1	Vest, Radio Carrier (Four Sizes) (Stock Number)	
	Extra Large	8300-978-500
	Large	8300-978-510
	Medium	8300-978-520
	Small	8300-978-530
1	Droppable Kit, Aerial Delivery consisting of: Parachute, Cargo Container, Aerial Delivery	AN/URC-4  G-7 modified A-20

SECTION II

TABLE OF SPECIFICATIONS

2-1. GENERAL.

2-2. The basic operating components of Radio Set AN/URC-4 consist of Radio Receiver-Transmitter RT-159/URC-4 or RT-159A/URC-4, Battery BA-1264/U and Special Purpose Cable Assembly CX-1093/U or CX-1093A/U. Depending upon the position of the operating controls, the equipment is capable of the three following types of operation.

NOTE

Radio Receiver-Transmitter RT-159A/URC-4 is a modified version of Radio Receiver-Transmitter RT-159/URC-4 and is identical to it operationally. Production changes in RT-159A, as compared to RT-159, are basically as follows:

- a. Simplified wiring
- b. Tubes V3 and V4 changed from type 5851 to USAF6147
- c. Resistor and capacitor changes to improve tone compensation
- d. Resistor changes to increase bias values and prolong tube life

In the following pages, these changes are noted where they are applicable.

2-3. AMPLITUDE-MODULATED VOICE TRANSMITTER. The radio set, in this type of operation, functions as a crystal-controlled oscillator-doubler transmitter with an output on a preset frequency in the VHF band between 120 and 130 megacycles, or in the

UHF band between 240 and 260 megacycles. The crystal generally supplied with the equipment provides for output on either the 121.5 or the 243.0 megacycle distress frequencies. The actual output frequencies of the equipment, as supplied to using personnel, is marked on the case of the radio receiver-transmitter.

2-4. TONE-MODULATED TRANSMITTER. The equipment, in this type of operation, acts as an amplitude-tone-modulated transmitter and can be either keyed for modulated continuous wave (MCW) operation for transmitting messages or distress signals, or the controls can be locked to provide a continuous tone-modulated signal when searching aircraft are using direction-finding equipment, or when injury or weakness of the using personnel make other types of operation impossible.

2-5. SUPER-REGENERATIVE RECEIVER. For reception, the equipment functions as a super-regenerative receiver, pre-tuned to one frequency in each band, usually the transmitter frequency. Two stages of audio-frequency amplification are provided and the received signal is heard through the "MIC-EAR-PHONE" aperture.

2-6. TUBE COMPLEMENT. Radio Set AN/URC-4 employs seven sub-miniature and one miniature electronic tubes. Their types, functions and locations are given in the following table. Since the functions of certain tubes change depending upon the type of operation employed, all types of operation are listed in the function column and explanatory footnotes are provided to clarify the different functions of these dual purpose tubes.



**TABLE II**  
**TUBE COMPLEMENT OF RADIO SET AN/URC-4**

QUANTITY	RT-159/URC-4 SERIAL 1-50	SERIAL 51-10637	RT-159A/URC-4 SERIAL 10637 and up	FUNCTION	LOCATION
1	CK 5676	USAF 6050*	USAF 6050	Crystal Oscillation (1), (2)	V1
1	CK 5676	USAF 6050*	USAF 6050	First R. F. Doubler (1), (2)	V2
1	MIL 5851*	MIL 5851	USAF 6147	Second R. F. Doubler (1), (2)	V3
1	MIL 5851	MIL 5851	USAF 6147**	Third R. F. Doubler (2)	V4
1	CK 5636	USAF 6050*	USAF 6050	VHF Detector (3)	V5
1	CK5676	USAF 6050*	USAF 6050	UHF Detector (4)	V6
1	2E32	2E32	2E32	First Audio Amplifier (3), (4) Speech Amplifier (5)	V7
1	JAN-3Q4	JAN-3Q4	JAN-3Q4	Voice Modulation (5) Audio Frequency Tone Generator (6) Audio Output Tube (3), (4)	V8

In RT-159B/URC-4, serial number 1 to approximately 16,000, tube types USAF 6147 and JAN2E32 were used for V3, V4 and V7 respectively. Tube types CK6397 and JAN5678 are used thereafter. CK6397 replaced USAF 6147 and JAN5678 replaced JAN2E32. In the event that tube replacement is required CK6397 is interchangeable with USAF 6147 and JAN5678 is interchangeable with JAN2E32.

\*In RT-159/URC-4 serial numbers 51 to approximately 250, an early version of CX5676 tube was used for V1, V2, V5, and V6. Tube type USAF 6050 is used thereafter, having been developed for the purpose. Use USAF 6050 for replacement. Since USAF 6050 has lower capacitances than the early CX5676, each corresponding stage must be realigned after replacement; and to retain coverage of the frequency range 240 to 260 mc by the UHF detector, coil L6 must be replaced with one from spare parts (higher inductance).

USAF 6050 is nearly equivalent to the final version of CX5676 and to JAN Type 5676 but it has a higher minimum gm and will operate at lower filament voltage--to give maximum battery life. The early 5676 is easily distinguished from the final 5676 by a fifth wire in the glass seal from which the four base-pins extend; the final tube has four pins and no extra wire in the seal.

\*\*USAF Type 6147 replaces MIL 5851 in the RT-159A/URC-4 units. The tubes are not interchangeable.

(1) VHF Transmitting Operation  
(2) UHF Transmitting Operation

(3) VHF Receiving Operation  
(4) UHF Receiving Operation

(5) Voice Modulation  
(6) Tone Modulation

**NOTE** Tube Types 6147 and 6397 are directly interchangeable with Tube Type 5851 and may be utilized in RT-159/URC-4 when supply of Tube Type 5851 is exhausted.

2-7. FUSE COMPLEMENT. No fuses are employed in Radio Set AN/URC-4.

2-8. FREQUENCY RANGES. Radio Set AN/URC-4 is equipped with a single crystal. Depending upon the crystal employed, the VHF output frequency may be selected to be at any point within the VHF frequency band of 120 to 130 megacycles. The UHF output frequency will be twice the VHF output frequency, within the UHF band of 240 to 260 megacycles. The crystals provided with Radio Sets AN/URC-4 when issued to using personnel are usually selected to provide a VHF output frequency of 121.5 megacycles and a UHF output of 243 megacycles so as to operate on the two emergency frequencies employed for rescue work. The receivers may be pre-tuned to any frequency within the two frequency bands. However, it is customary to tune the receivers to the same frequency as the transmitter.

2-9. OUTPUT CHARACTERISTICS. The output of the transmitter, when properly tuned, is better than 35 milliwatts on each frequency band. Modulating capabilities, both voice and tone modulation, are better than 90% negative modulation.

2-10. OPERATING VOLTAGES AND CURRENTS. Radio Receiver-Transmitter RT-159/URC-4 or RT-159A/URC-4 requires a maximum of 45 milliamperes at 125 volts D.C. for plate and screen supply to the tubes and a maximum of 520 milliamperes at 1.25 volts for the filament supply. These voltages are supplied by Battery BA-1264/U. The battery has a life of approximately 24 hours of continuous operating in cycles of five minutes of transmitting and five minutes of receiving. The battery life is considerably extended if the equipment is shut down between operating periods, or if the receiving periods are longer than the transmitting periods.

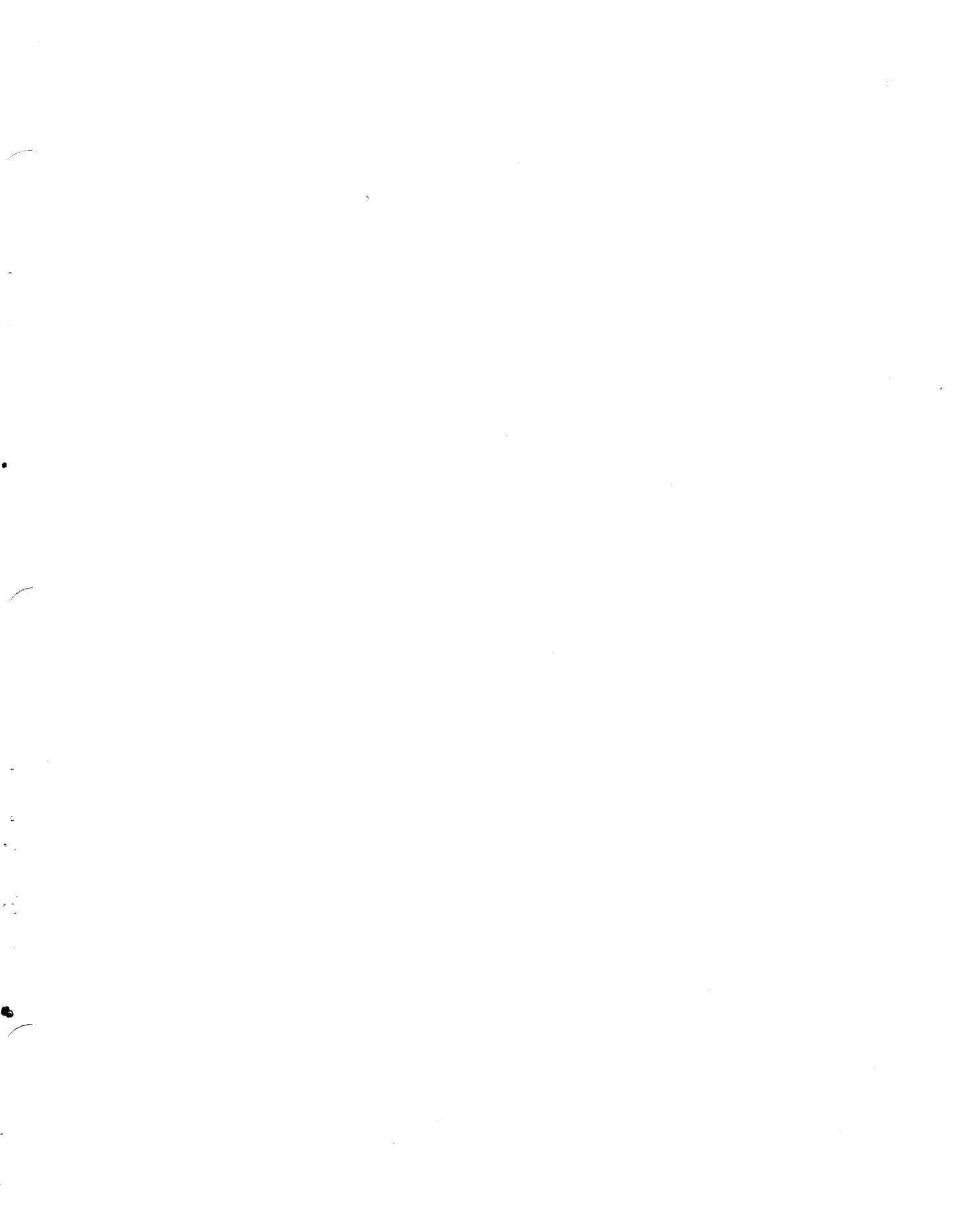



SECTION III  
THEORY OF OPERATION

## 3-1. GENERAL.

3-2. Radio Set AN/URC-4 is a self-contained, self-powered radio receiver-transmitter combination that is capable of transmitting on a single predetermined frequency in the VHF band between 120 and 130 megacycles or in the UHF band on a harmonically-related frequency between 240 and 260 megacycles. The output of the transmitter can be either voice- or tone-modulated.

The equipment will receive on a single preset frequency in the VHF band and in the UHF band.

## 3-3. GENERAL SYSTEM OPERATION.

3-4. The general operation of Radio Set AN/URC-4 is described in the following paragraphs. This discussion, together with three block diagrams, Figures 3-1, 3-2 and 3-3 cover, broadly, the circuits employed during the

Section III  
Paragraphs 3-5 to 3-8

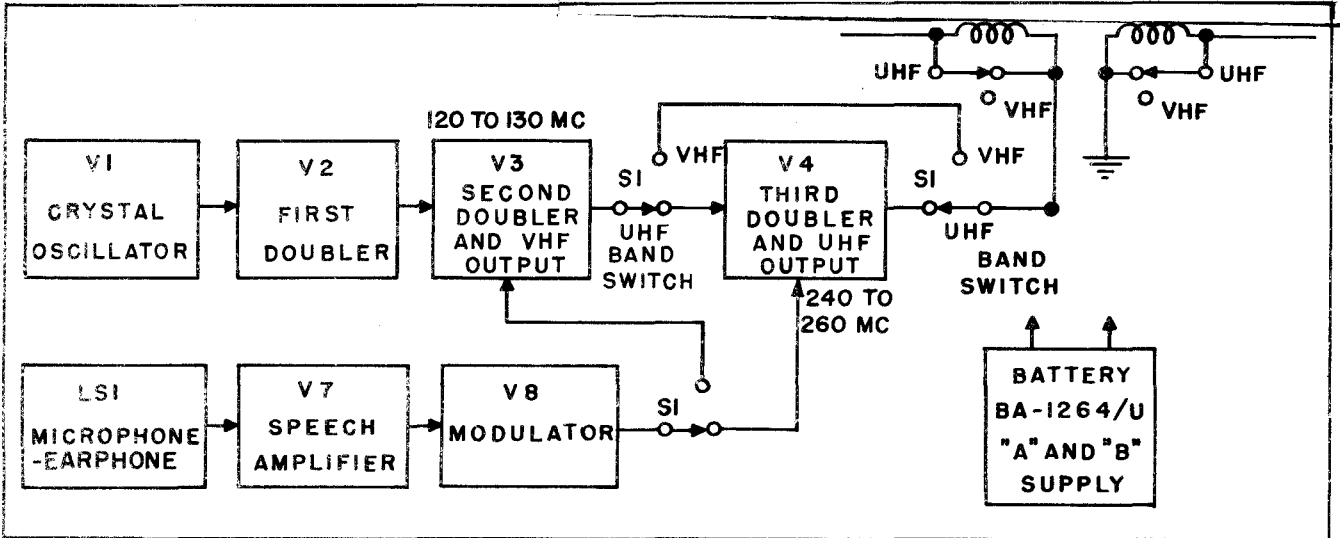

Figure 3-1. Block Diagram, Voice Transmission, UHF Condition

three types of operation of which the equipment is capable.

3-5. TRANSMISSION, VOICE. Figure 3-1 is a simplified block diagram showing the circuits when the radio set is employed for transmitting voice messages.

3-6. RADIO FREQUENCY GENERATING CIRCUITS. The radio frequency generating circuits are comprised of a crystal oscillator, a first doubler, a second doubler that also acts as the output stage when the equipment is operated in the VHF range. A third doubler is energized, and acts as the output stage when operation in the UHF range is desired. The BAND SWITCH S1 turns on the third doubler, connects the third doubler output to the antenna and disconnects the modulation from the second doubler when UHF operation is employed.

3-7. SPEECH AMPLIFIER AND MODULATOR STAGES. The sounds of the voice are translated into electrical

voltage variations by the "MIC-EARPHONE" which, in this mode of operation, acts as a dynamic microphone. These voltage variations are applied to the grid of the speech amplifier stage by a step-up transformer, and amplified in the stage to drive the modulator tube. The output of the modulator tube is applied to the D.C. supply to the r-f output stage in use so as to amplitude modulate the plate and screen voltage to the stage and consequently the radiated carrier wave from the antenna.

3-8. TRANSMISSION, TONE. The function of the radio frequency generating circuits during operation with tone modulation are the same as during voice transmission. However, as shown in Figure 3-2, when the "TONE" switch S2A is depressed, two switching actions take place in the audio frequency and modulator stages, and a side-tone is provided so that the operator may monitor his transmission.

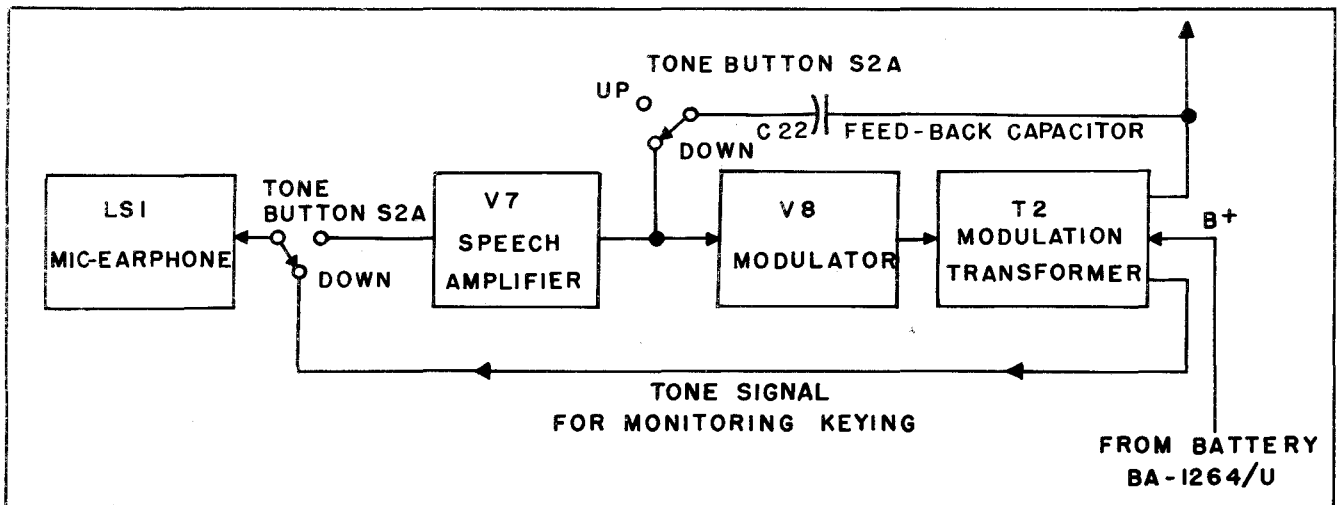

Figure 3-2. Block Diagram, Audio Frequency Circuits for Tone Modulation

3-9. **TONE GENERATOR.** The action of the "TONE" switch couples a feed-back capacitor between the output and input of the modulator stage causing it to become an audio oscillator. The output is a 1,000 cycle tone that is applied as a modulating voltage to the r-f output stage.

3-10. **SPEECH AMPLIFIER STAGE.** The input to this stage is disconnected, allowing it to stand idle when the "TONE" switch is depressed.

3-11. **SIDE TONE.** The "MIC-EARPHONE" is connected to a winding on the modulation transformer so that a small portion of the output of the tone generator is applied to the "MIC-EARPHONE" which functions as a dynamic speaker, and provides a side tone for use in monitoring the transmission.

3-12. **RECEIVING.** Figure 3-3 is a simplified block diagram showing the circuits employed when the radio set is operating in the receiving condition. This connection of the electrical components is obtained when the "REC" button is depressed.

3-13. **DETECTOR CIRCUITS.** The antenna is connected to the tuning inductances of both the UHF and the VHF detector circuits when the equipment is used for receiving. However, the action of the "BAND SWITCH" is such that power is applied to the filament of only one of the two detector tubes; the detector in use is determined by the position of the switch. These detectors are of the self-quenched super-regenerative type, each pre-tuned to a frequency in its operating band.

3-14. **AUDIO AMPLIFIER STAGES.** The output of the detector in use is coupled to the first audio amplifier stage, amplified and applied to the audio output stage. The output of this stage is connected to the "MIC-EARPHONE" which acts as a dynamic speaker.

3-15. **FUNCTIONAL OPERATION OF ELECTRONIC COMPONENTS.**

3-16. **FUNCTIONAL OPERATION DURING TRANSMISSION.** Figure 3-4 is a simplified schematic diagram of the electronic components in the radio frequency generating circuits during UHF transmitting operation. The circuits are connected in this fashion when the "TRANS" button S2B is depressed. The actions of the "BAND SWITCH" S1 are shown in this simplified diagram with the switch in the "UHF" position. The connections made by the switch in the "VHF" position are indicated so that the band-changing operation may be studied. Figure 3-5 is a simplified schematic of the antenna connections. Figure 3-6 (see paragraph 3-22) is a simplified schematic of the speech amplified and modulator stages only. Figure 3-7 shows the action of the TONE switch S2A when transmitting a tone-modulated signal. A detailed description of the various stages follows.

3-17. **CRYSTAL OSCILLATOR STAGE.** The crystal oscillator stage generates the radio frequency voltage that determines the output frequency of the transmitter. It is comprised of the sub-miniature type USAF 6050 triode tube V1 and its associated components. These form a Miller type crystal oscillator circuit. The crystal employed is a type CR-24/U harmonic-mode crystal and the output of the stage is between 30 and 32.5 mc. R1 is the grid resistor that provides bias necessary for operation. L1 is the plate inductance for the stage, and provides feed-back to sustain oscillation through a small link inductively coupled to the plate inductance. When L1 is properly tuned to the crystal frequency, a strong output is generated. The output of the stage is taken from a high impedance point on L1 and coupled to the grid of the first doubler tube V2 through capacitor C1.

3-18. **FIRST DOUBLER STAGE.** This stage doubles the frequency of the crystal detector stage and also acts as a buffer amplifier between the crystal oscillator stage and the modulated VHF amplifier-doubler stage V3. It is comprised of the type USAF 6050 sub-miniature

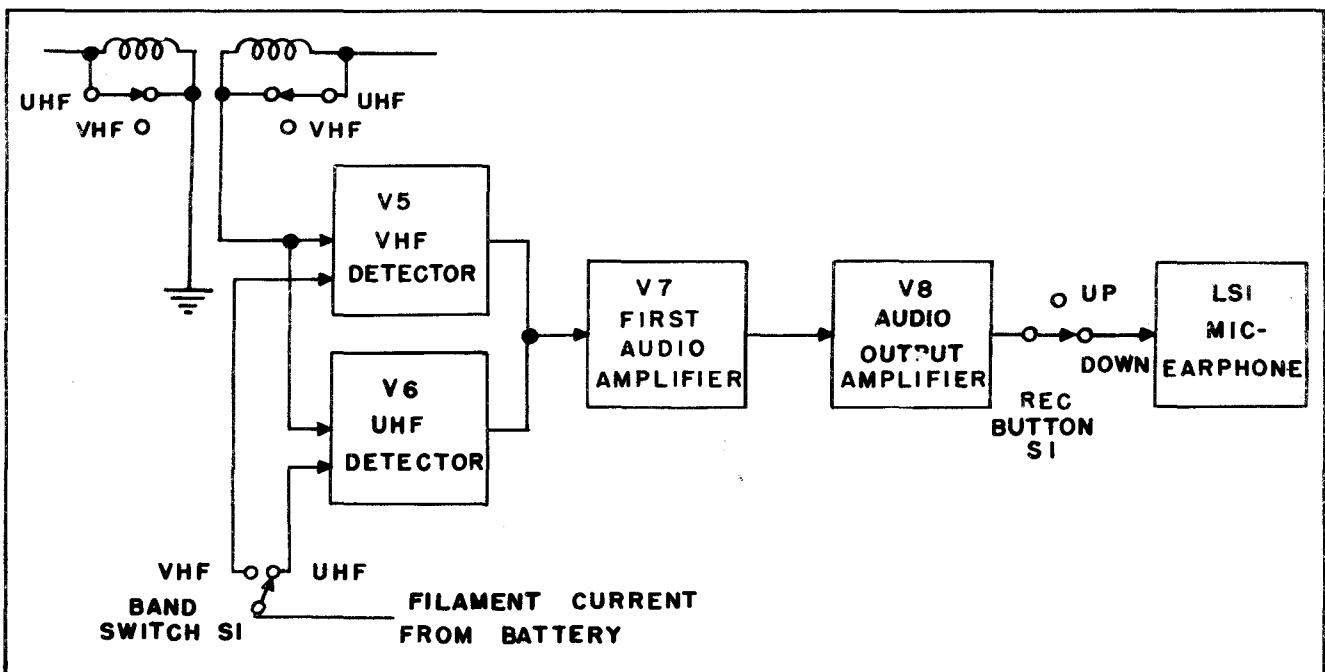

Figure 3-3 Block Diagram, UHF Receiving Condition

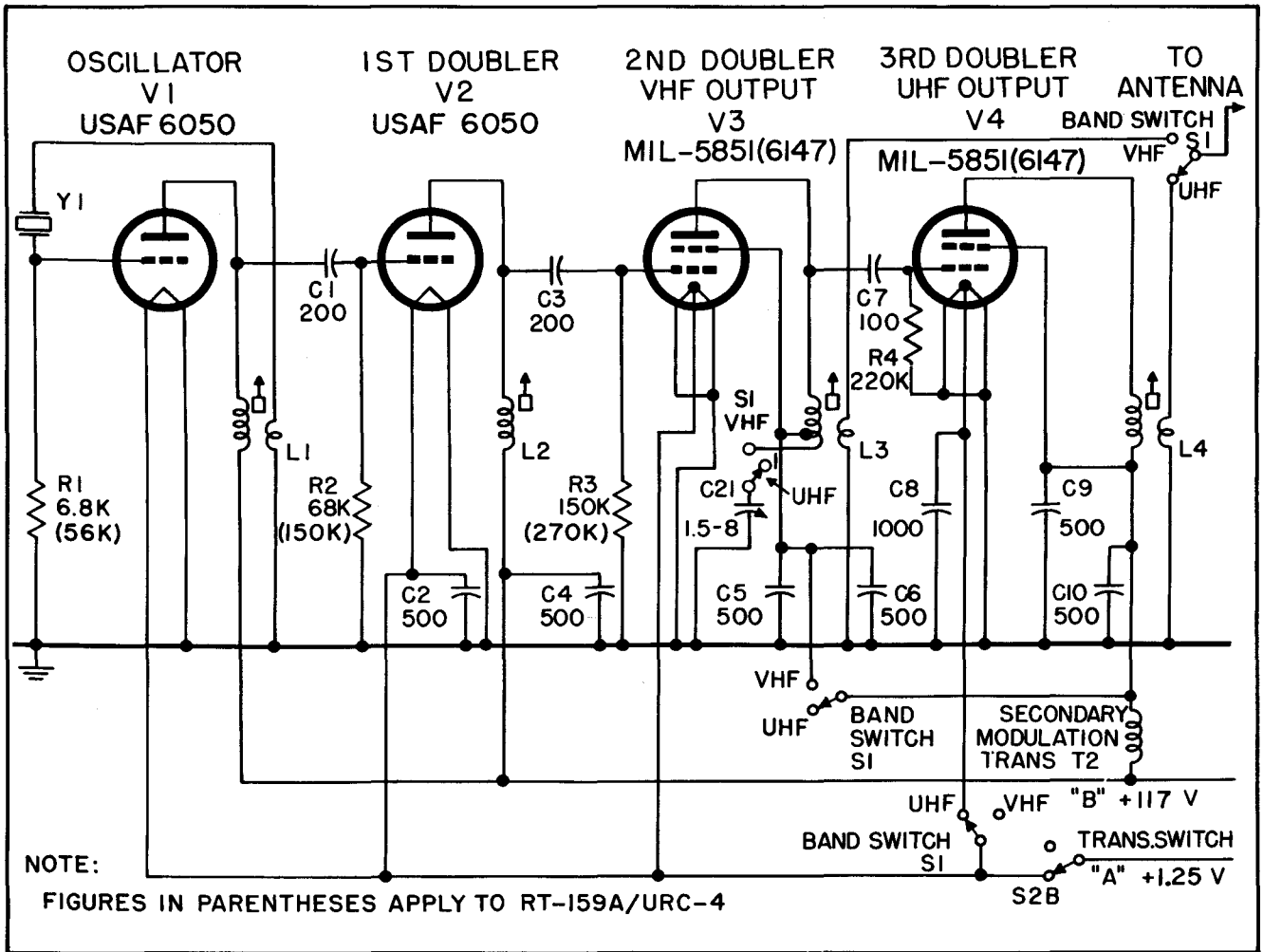

Figure 3-4. Simplified Schematic Radio Frequency Generating Circuits

triode tube V2 and its associated components. It is a standard over-driven class C type amplifier with high grid bias and high impedance plate load to develop a maximum of second harmonic voltage across plate inductance L2. Grid resistor R2 provides grid bias for the tube. L2, the plate inductor, is permeability tuned to twice the input frequency. The output of the stage is coupled to the following stage from a high impedance point in the plate circuit by the 200 mmf capacitor C3.

**3-19. SECOND DOUBLER AND VHF OUTPUT STAGE.** This circuit acts as the r.f. output stage of the transmitter when operated in the VHF band, and as a second doubler when operating in the UHF band. It is comprised of the sub-miniature pentode tube V3. With either type of operation, the stage functions as a class C doubler with its plate inductance tuned to twice the input frequency to provide an output of between 120 and 130 megacycles. When the stage is operated as the VHF output stage, modulation voltage is supplied to the plate and screen grid of the tube through the "BAND SWITCH" S1. This switch also couples the link coil of plate inductor L3 to the antenna. Capacitor C21 is connected inductively to L3 and, together with the permeability of the core of the inductor, serves to tune the stage to resonance when operating in the VHF band. The purpose of this capacitor

is to compensate for the differences in loading between the antenna and the grid of the following stage when switching between the antenna and the grid of the following stage when switching between the VHF and UHF bands, and it is disconnected when operating on the UHF band by S1.

**3-20. THIRD DOUBLER AND UHF OUTPUT STAGE.** This stage is employed only when transmitting on the UHF band at which times it acts as a third doubler into the 240 to 260 mc. band. Its output is coupled to the antenna through the action of the "BAND SWITCH" S1. When operating in the VHF band, the stage is disabled by removing the filament supply, and the cold tube with its coupling components remain as part of the capacitive elements of the plate tank circuit of V3. The stage is comprised of the sub-miniature pentode tube V4 and its associated components. The plate inductance of the stage is provided by L4 which is permeability tuned to the output frequency. Coupling to the antenna from this stage is by means of a small link on L4 that is connected to the antenna by the "BAND SWITCH" S1 when the switch is in the UHF position. C8 is provided as an r-f bypass capacitor for the high side of the filament and C9 and C10 respectively are the screen bypass and B+ bypass capacitors.

3-21. ANTENNA. The antenna is an unbalanced doublet type that provides radiation in both the horizontal and vertical planes. Radiation in the vertical elements will be vertically polarized and from the horizontal elements,

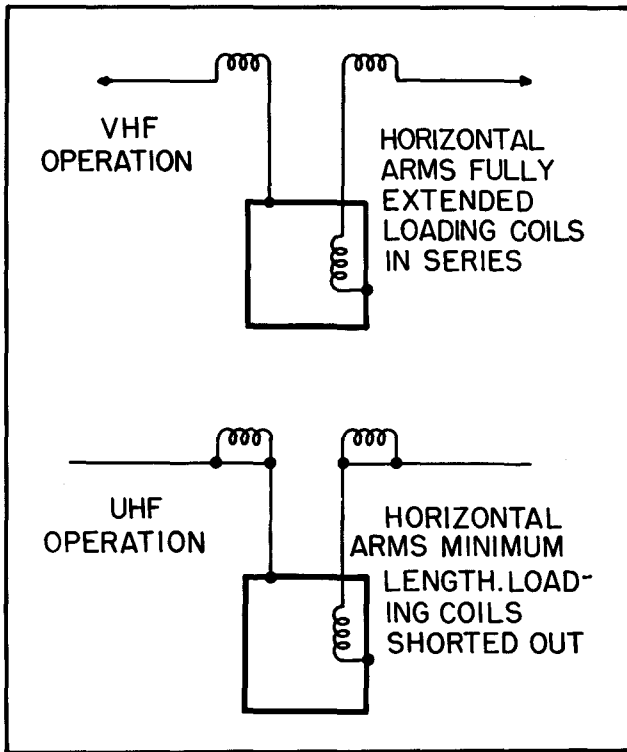

Figure 3-5. Simplified Schematic, Antenna Connection, VHF and UHF

horizontally polarized. This unbalance of the antenna can be seen by reference to Figure 3-5. It will be noted that the ground points of the vertical legs are unsymmetrical. One leg is grounded at the top of the case, while the other, the feeder leg, is grounded through the coupling loop at a point within the case. When in the VHF condition (vertical arms and horizontal arms fully extended) the grounding effect is balanced for the horizontal arms through the difference in the values of inductance of the two series coils in the antenna head. When in the UHF condition, these coils are shorted out and the two horizontal dipole arms are mechanically symmetrical. However, in this condition, unbalance is obtained through the fact that one leg is grounded at the top of the case while the other is terminated to ground through the coupling inductance of the UHF output stage.

3-22. SPEECH AMPLIFIER AND MODULATOR CIRCUITS. Figure 3-6 shows the simplified schematic diagram of the speech amplifier and modulator circuits employed for voice modulation. The circuit is shown with the "TRANS" switch S2B depressed. Alternate switch positions that are employed when the equipment is operated for receiving are shown, but the connections are not included.

3-23. The sound waves of the operator's voice are translated into electrical voltage variations through the actions of LS1 that functions as a dynamic microphone. The low impedance output of LS1 is applied to the primary of transformer T1. T1 has an impedance ratio of 12 ohms to 300,000 ohms, and applies a high impedance voltage to the grid of the speech amplifier tube V7. The 33,000 ohm resistor R13 and capacitor C23 form an isolation circuit between the grid of V7 and transformer T1 so as to prevent the output of the detector tubes from

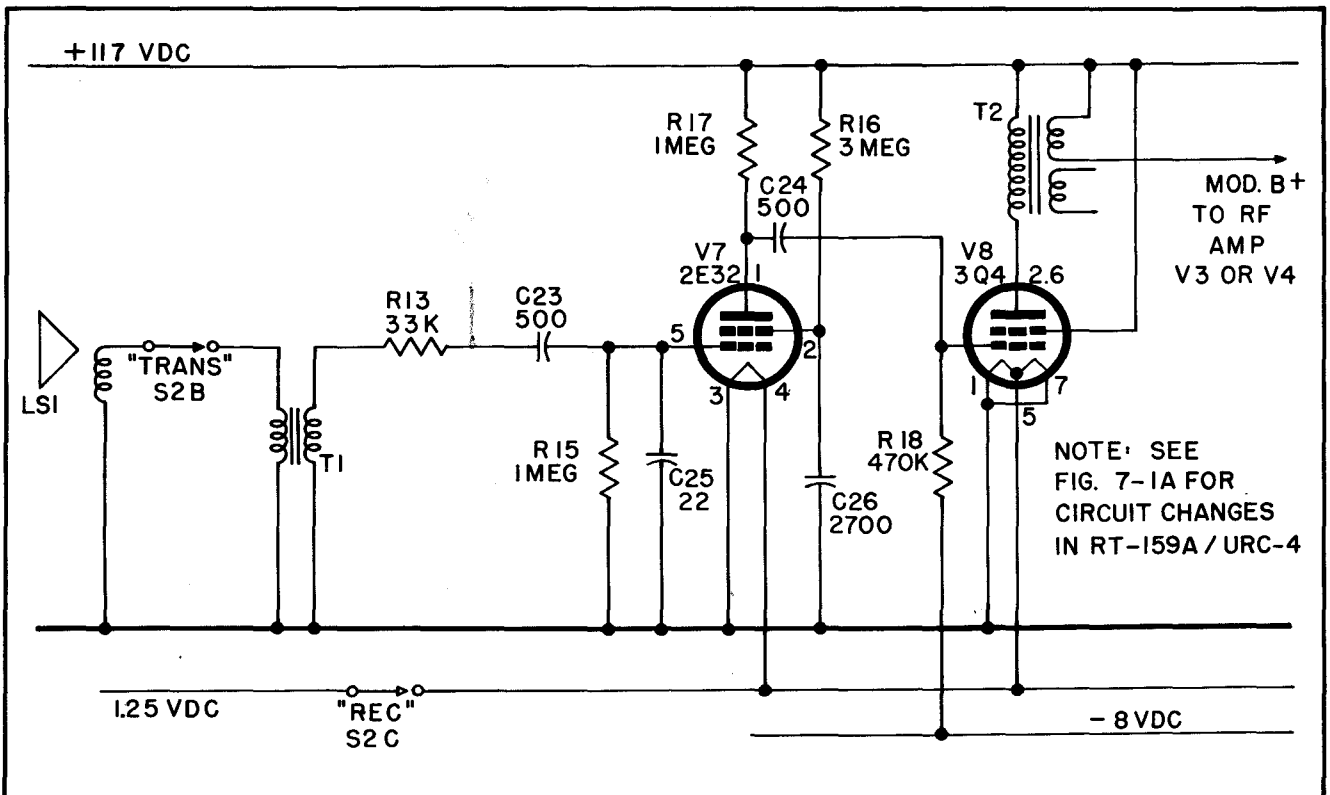

Figure 3-6. Simplified Schematic, Speech Amplifier and Modulator Circuits, RT-159/URC-4

being dissipated in the transformer when the equipment is operated in the receiving condition.

3-24. The first speech amplifier stage is comprised of the sub-miniature tube V7, a type 2E32 triode, and its associated components. The high value of the grid resistor R15 (R16 on RT-159A/URC-4) and the high amplification factor of the tube provide for a high gain in this stage. C25 acts as an r.f. bypass capacitor for stray r.f. voltages. The output of the stage is capacitively coupled to the modulator V8 by capacitor C24.

3-25. The Type JAN-3Q4 pentode tube V8 functions as the modulator tube when the equipment is operated for voice transmission. It is a Class A power amplifier and the output of the plate appears across the primary winding of T2, the modulation transformer. The plate and screen voltage supply for the r.f. output stage in use is supplied through the secondary winding of the modulation transformer, thus modulating the r.f. output stage in use.

3-26. A negative bias voltage necessary for proper operation of V8 is provided by dropping resistor R10 in series with the negative return lead of the 125-volt plate and screen supply from the battery. This resistor provides proper bias when operated in the transmitting condition. When in the receiving condition, with the transmitting tubes turned off, the current passing through the resistor is decreased and an additional resistor R11 is switched in series with R10 to provide proper bias voltage when receiving.

3-27. FUNCTIONAL OPERATION DURING TONE MODULATION. The operation of the r.f. components during tone modulation transmissions is the same as described for voice transmission. However, as shown in Figure 3-7, the modulator tube V8 is switched so that, with its associated components, it becomes an audio frequency oscillator with an output of approximately 1,000 cycles. This output, by means of the modulation transformer, tone modulates the VHF or UHF output stage, whichever is in use.

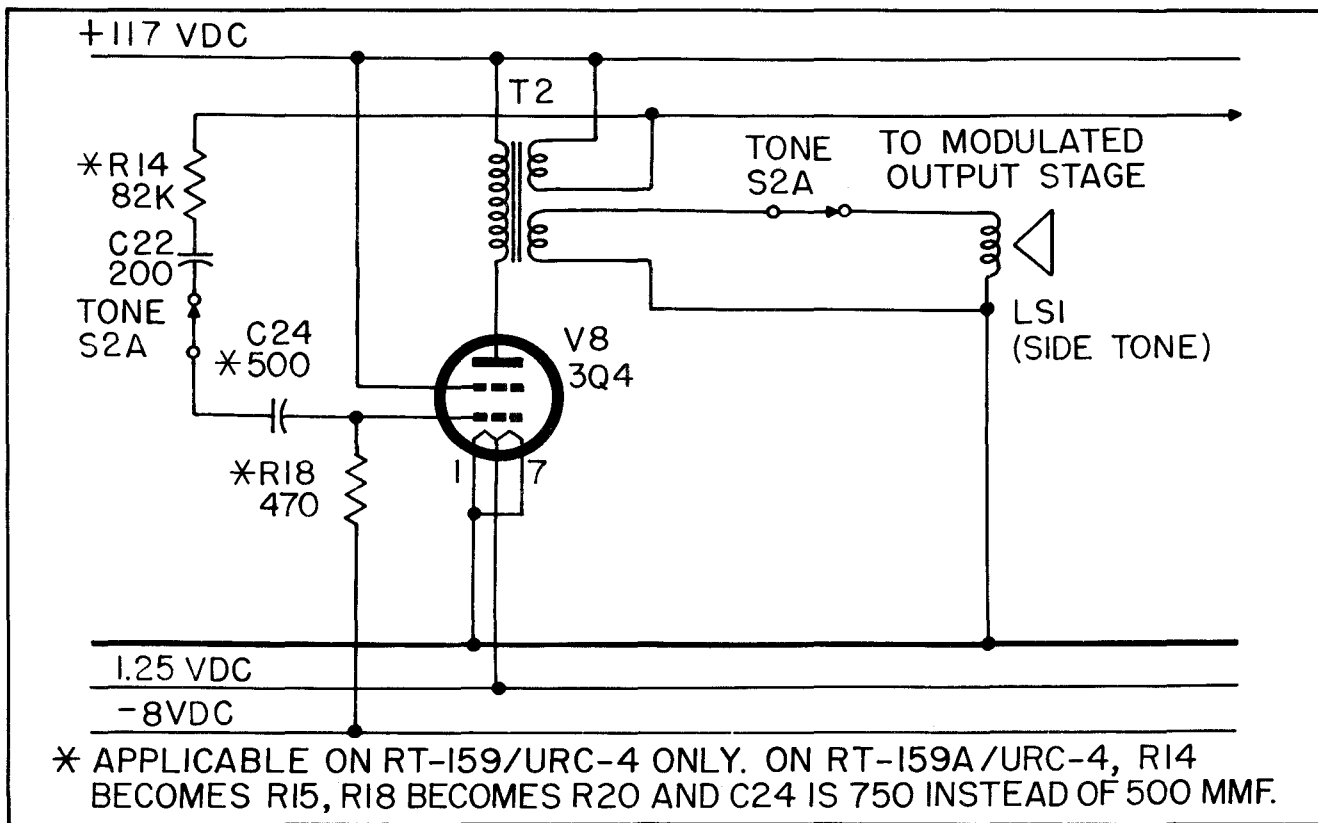

Figure 3-7. Simplified Schematic, Tone Generating Circuits

3-28. The "TONE" switch S2A connects feed-back capacitor C22 in series with R14 (R15 on RT-159A/URC-4) between the plate and grid of V8. This causes the tube to oscillate at an audio frequency determined by the value of the resistor and the capacitor, or approximately 1,000 cycles. Switch S2A also connects the "MIC-EARPHONE" LSI in series with resistor R12 to the low-impedance winding on modulation transformer T2 so that LSI is supplied with an audio tone voltage while S2A is depressed. LSI acts as a dynamic speaker in this mode of operation, and produces an audible side-tone that may be used for monitoring the keying of the transmitter.

3-29. FUNCTIONAL OPERATION DURING RECEPTION. Radio Set AN/URC-4 functions as a super-regenerative receiver with two stages of audio amplification when used in the receiving condition. Filament current is not supplied to the transmitter section during this operation and consequently these stages do not function. A simplified schematic diagram of the equipment in the receiving condition is shown in Figure 3-8.

3-30. UHF AND VHF DETECTORS. Two individual self-quenched super-regenerative detectors are provided in the radio receiver-transmitter. As shown in Figure

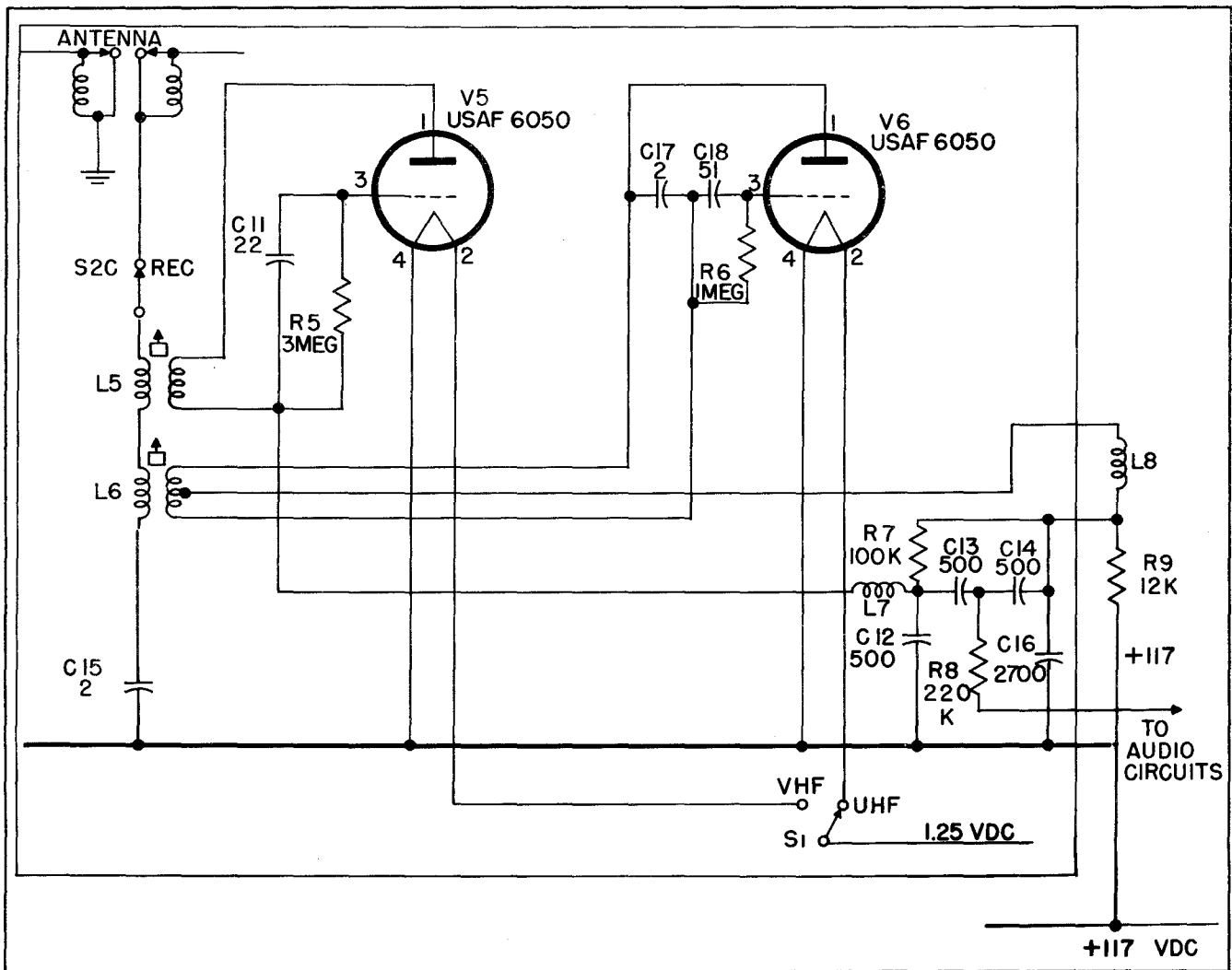

Figure 3-8. Simplified Schematic, VHF and UHF Detector Circuits

3-8 the input inductances of these two detectors are connected in series. However, only one detector is in use at any given time, since the other detector is disabled by the action of the "BAND SWITCH" S1 which supplies filament voltage to only one stage at a time.

position, filament current is supplied this stage and removed from V5. The output of this stage is coupled to the audio amplifier V7 through capacitor C14. L8 and C16 act as the r.f. filter for this detector.

3-33. Both detector stages are reactance-tuned by adjusting the tuning slug in the center of the tuning coil forms. C19, a 20 mfd electrolytic capacitor, acts as a low impedance to audio voltages in the B+ circuit. This prevents audio oscillation due to common coupling when the internal resistance of the battery is high, as when partially discharged.

3-34. FIRST AUDIO AMPLIFIER STAGE. The first audio amplifier stage consist of the type 2E32 sub-miniature tube V7 and its associated components. The output of the detector in use is coupled to the grid of the tube through the 220K series resistor R8. R8 serves to prevent the voice frequencies present on the grid of the tube during transmission from being dissipated in the detector circuits. R13 acts as a series resistor to prevent the output of the detector stages from being dissipated through the input transformer T1. The stage acts as a high-gain Class A amplifier. Its output is coupled to the grid of V8 through capacitor C24.

3-31. V5, a Type USAF 6050 tube, is the VHF detector. When the switch S1 is in the VHF condition, filament current is supplied this tube and removed from the UHF detector V6. Super-regenerative action is developed by the connection of the grid to the high voltage supply through the 3 megohm resistor R5. The value of R5 and capacitor C12, plus the connection of the grid to the high voltage, cause an alternate blocking and unblocking action at a frequency of approximately 80,000 cycles per second, giving the stage a self-quenched super-regenerative action. Output of the stage is coupled to the grid of V7 through capacitor C13. Inductance L7 and capacitor C12 acts also as an r.f. filter to prevent stray r.f. from reaching the audio stages. The stage is tunable to any frequency between 120 and 130 megacycles.

3-32. V6 and its associated components form a similar detector circuit tunable to any frequency between 240 and 260 megacycles. When the band switch S1 is in the UHF  
Revised 1 March 1951



3-35. **SECOND AUDIO AMPLIFIER STAGE.** The Type JAN-3Q4 miniature pentode tube acts as a second audio amplifier stage when the equipment is used for receiving. It should be noted that the connections to the modulation transformer T2 remain the same as when used as a modulator during transmission. However, since the modulated r.f. tubes are not supplied filament current during the receiving operation, they act to open-circuit. The modulation winding of T2. However, switch S2C, the "REC" switch, when closed, serves to connect LS1 across a low-impedance winding of the transformer, supplying the amplified audio signal to LS1. LS1 then acts as a dynamic speaker to convert the audio frequency electrical signals to audible sound waves that are heard by the operator.

3-36. The -8 volt grid bias for V8, under receiving conditions, is developed by passing the negative return to the 125-volt plate supply through resistors R10 and R11. R11 is added in series with R10, the bias resistor used when transmitting, to maintain the same grid bias during both receiving and transmitting operations. This is necessary since the r.f. tubes are inoperative during reception, and the total current flow in the 125-volt return circuit is less during reception than transmission. The addition of R11 compensates for this decrease in current flow, and provides proper operating bias for the tube.

3-37. **ANTENNA.** The antenna is connected to the receiving circuits by switch S2C and functions in the same manner during reception as during transmission.

**SECTION IV**

**TEST EQUIPMENT AND SPECIAL TOOLS**

4-1. **TEST EQUIPMENT.**

4-2. The test equipment required for maintenance of Radio Set AN-URC-4 is itemized in the following table.

4-3. No special tools are required or supplied. However,

an alignment wrench is provided. Due to the small size and compact arrangement of the unit, maintenance personnel should use small tools, a small soldering iron and other small implements such as are employed in maintenance and repair of meters, and other small and compact electronic equipment.

TABLE III		
TEST EQUIPMENT		
Part Or Type No.	Nomenclature	Application
TS-684/URM-30	Analyzer	Provides test signal for aligning detectors; measures voltages.  Measures voltage, resistance and current.

SECTION V

TROUBLE SHOOTING, REPAIR AND OVERHAUL

5-1. GENERAL.

5-2. The components requiring maintenance, repair and overhaul are, for the most part, located in Radio Receiver-Transmitter RT-159/URC-4. Especial care should be taken when working on this unit due to the fact that the sub-miniature parts employed are delicate and easily damaged. Use only small tools, and do not force tubes and other parts when checking, testing, removing and replacing.

5-3. OPENING THE RECEIVER-TRANSMITTER CASE. The catch on Receiver-Transmitter RT-159/URC-4 and RT-159A/URC-4 is shown in figure 5-1. The case is opened by slipping a knife-blade or small screwdriver under the catch until the locking spring is lifted above the catch on the case. Do not twist or lift on the tool when opening the case. To do so may distort the case and thus make the water-proof seal ineffective when reassembled. The RT-159B/URC-4 case is opened simply by loosening the three screws located at both ends of the cover.

5-4. REMOVING THE CHASSIS FROM THE CASE. The chassis is secured to the case by three small screws indicated as "chassis mounting screws" on fig-

ure 5-2. When these screws are removed, the chassis may be lifted from the case as shown in figure 5-3.

NOTE

Before removal of the chassis from the case is attempted, tubes V-5 and V-7 will be removed from their respective sockets. This procedure is required in order that the chassis mounting screw directly behind tube V-7 can be removed without damage being inflicted to the coating (Shield) of V-7.

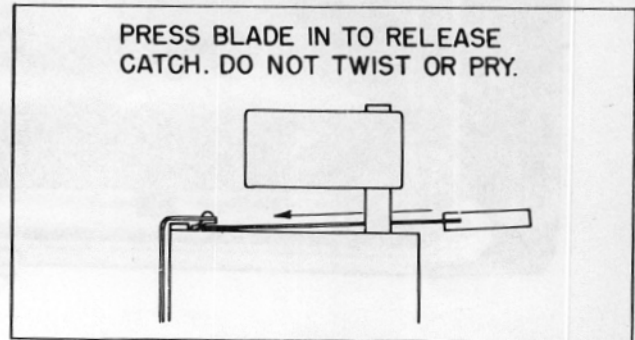

Figure 5-1. Removing Cover from the Radio Receiver-Transmitter Case

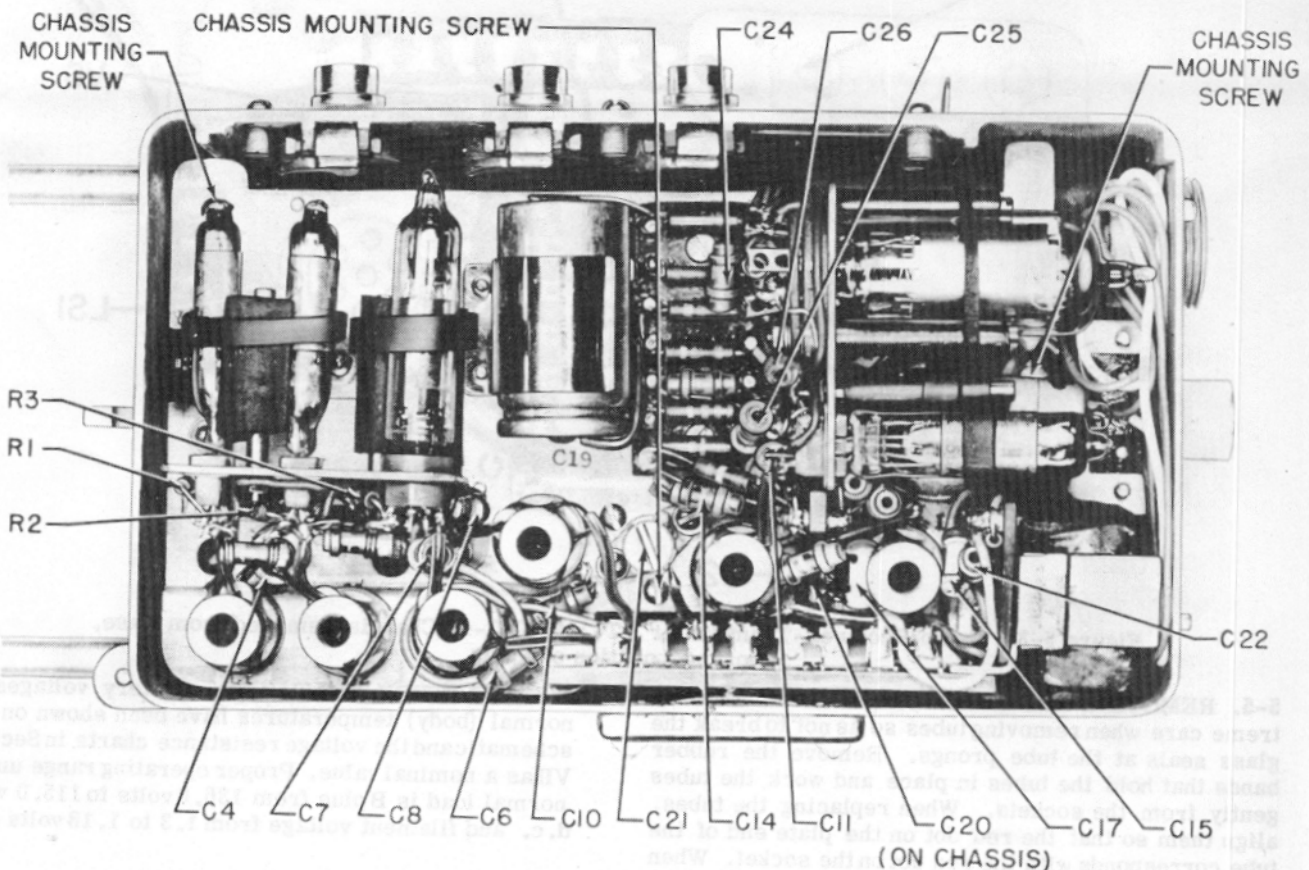

Figure 5-2. Radio Receiver-Transmitter RT-159/URC-4, Cover Removed, Showing Location of Parts

Revised 15 October 1958

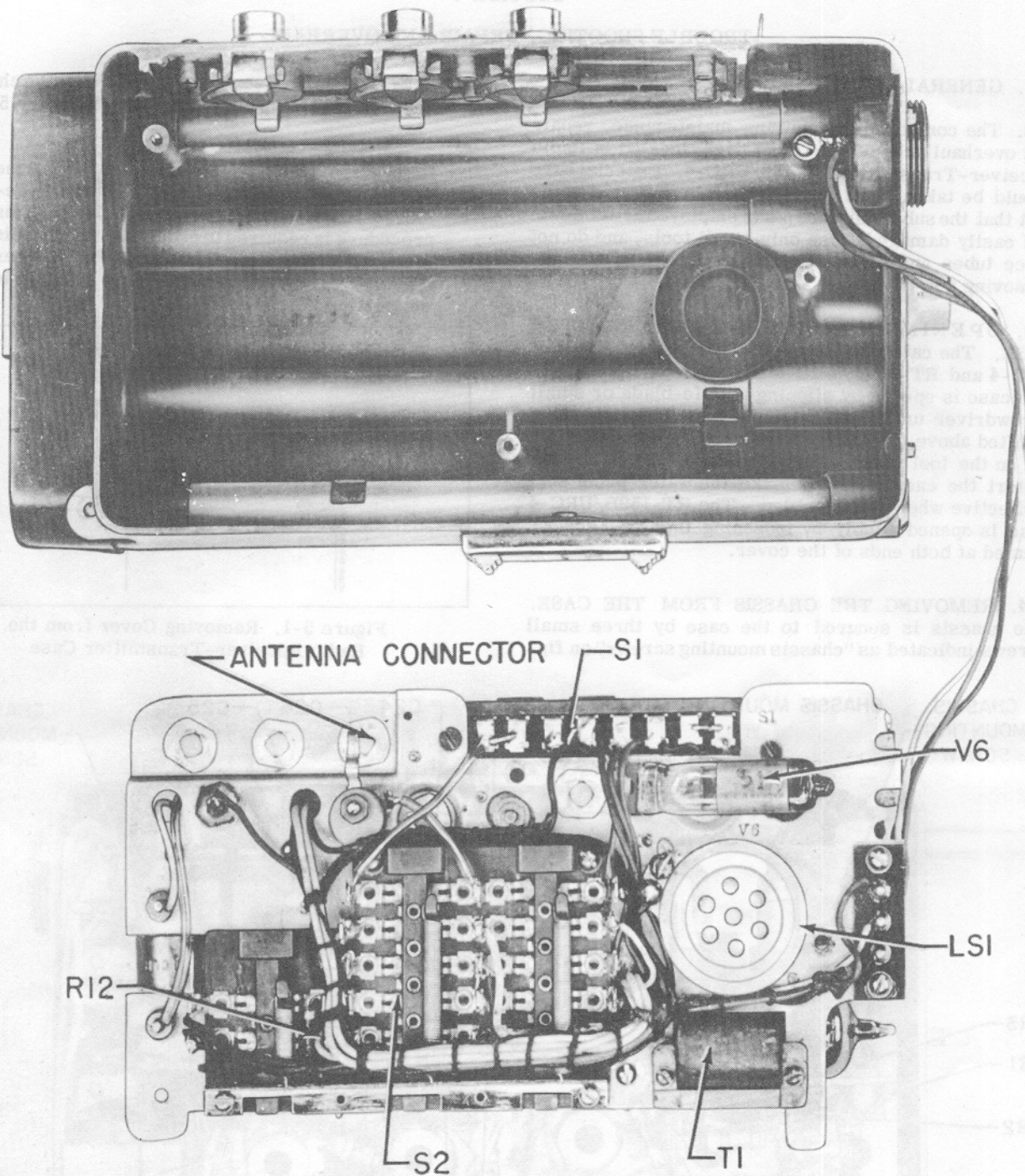

Figure 5-3. Radio Receiver-Transmitter RT-159/URC-4, Chassis Removed from Case, Showing Location of Parts

5-5. REMOVING AND REPLACING TUBES. Use extreme care when removing tubes so as not to break the glass seals at the tube prongs. Remove the rubber bands that hold the tubes in place and work the tubes gently from the sockets. When replacing the tubes, align them so that the red dot on the plate end of the tube corresponds with the red dot on the socket. When installing a new tube V6, place the tube in the socket with the pins unbent, and carefully bend the prongs so that the tube lies parallel to the chassis.

5-6. BATTERY VOLTAGES. Battery voltages at normal (body) temperatures have been shown on the schematic and the voltage resistance charts in Section VII as a nominal value. Proper operating range under normal load is B plus from 136.0 volts to 115.0 volts d. c. and filament voltage from 1.3 to 1.18 volts d. c.

TABLE IV

## COMPARISON OF COMPONENTS IN MODELS RT-159/URC-4 AND RT-159A/URC-4

The following table gives a comparison of resistors and capacitors showing symbol numbers, value and reasons for changes:

RT-159/URC-4		RT-159A/URC-4		
Symbol No.	Value	Symbol	Value	Reasons
R1	6.8K	R1	56K	(Oscillator grid resistor) (1st doubler grid resistor) (2nd doubler) (R1, 2, 3 changed to reduce grid current of tubes)
R2	68K	R2	150K	
R3	150K	R3	270K	
R4	No Change			
R5	No Change			R10 increased to maintain cathode bias voltage with less plate current Transmitter Bias Resistance. Bias Compensation
R6	No Change			
R7	No Change			
R8	No Change			
R9	No Change			
R10	180 ohm	R10	270 ohm	
R11	560 ohm	R11	470 ohm	
R12	No Change	R12		
R13	No Change	R13		
		R14	68K	
R14	No Change	R15		1st Audio bias bleeder network (159A only)
R15	No Change	R16		
R16	No Change	R17	10K	Same use as R14
R17	No Change	R18		
R18	No Change	R19		
R19	No Change	R20		
C1	No Change			
C14				
C15	2 uuf	C15	2 uuf	Different temperature coefficient.
C16	No Change			
C22				Tone compensation on 159A only
C23	500 uuf	C23	750 uuf	
C24	500 uuf	C24	750 uuf	
C25	No Change	C25		
C26	No Change	C26		
C27	No Change	C27		
		C28	1000 uuf	



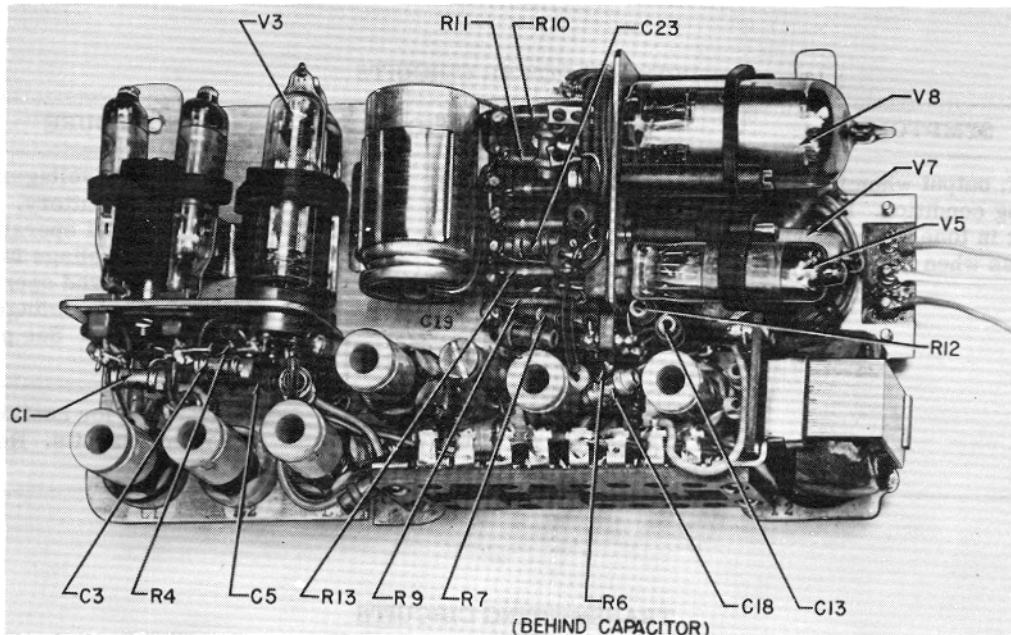

Figure 5-4. Radio Receiver-Transmitter RT-159/URC-4, Main Chassis, Top View From Right.

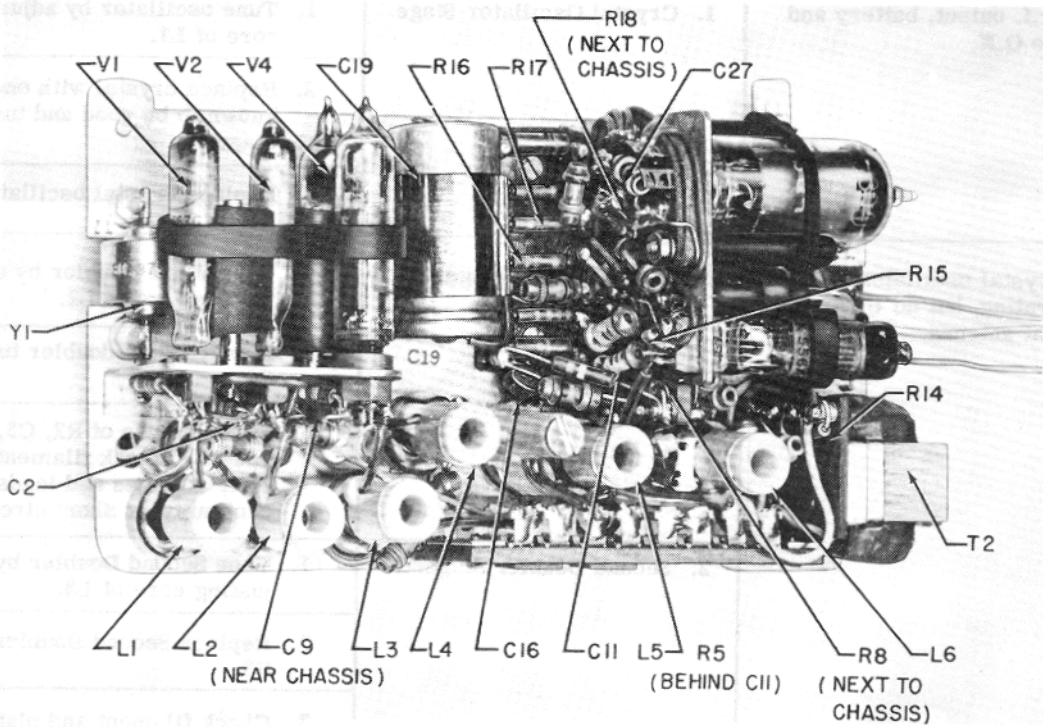

Figure 5-5. Radio Receiver-Transmitter RT-159/URC-4, Main Chassis, Top View From Left

5-7. TROUBLE-SHOOTING CHARTS. Four charts are included for use when trouble-shooting. These charts are designed to assist maintenance personnel to locate troubles in each of the three operating conditions of the equipment. They trace the circuits through their normal sequence of operation, and maintenance personnel, by following the charts can effectively isolate and locate the point where trouble is occurring in the various circuits. Reference to Figures 5-2 to 5-5 inclusive

will help to locate the parts to be checked. The schematic diagram and wiring diagram will further aid in trouble-shooting. Socket diagrams have been included on the schematic to show the location of the tube pins where the numbers cannot be read. The schematic, wiring diagrams and voltage and resistance charts included in Section VII will be of further aid in assisting the trouble-shooter.

## PRIMARY POWER CIRCUITS

SYMPTOM	TROUBLE LOCATION	PROCEDURE
1. No r.f. output when in transmitting condition. No tone output in tone modulation. No hiss when receiving.	1. Battery BA-1264/U.	1. Check battery voltages at connector on battery. Replace battery if operating plate supply voltage is below 120 volts and operating filament supply voltage is below 1.2 volts. See paragraph 5-6.
	2. Special Purpose Cable Assembly CX-1093/U.	1. Check cable for continuity and short circuits. Replace if defective.

## TRANSMITTING CIRCUITS

SYMPTOM	TROUBLE LOCATION	PROCEDURE
1. No r.f. output, battery and cable O.K.	1. Crystal Oscillator Stage.	1. Tune oscillator by adjusting core of L1.
		2. Replace crystal with one known to be good and tune stage.
		3. Replace crystal oscillator tube.
2. If crystal oscillator is operating, but no UHF output at antenna.	1. First Doubler Stage.	1. Tune First Doubler by adjusting core of L2.
		2. Replace first doubler tube V2.
		3. Check values of R2, C3, C4 and L2. Check filament and plate voltages and leads for continuity or short circuits.
	2. Second Doubler Stage.	1. Tune Second Doubler by adjusting core of L3.
		2. Replace Second Doubler tube V3.
		3. Check filament and plate voltages and values of R3, C5, C6 and L3. Check leads for continuity or short circuits.
		4. Place "BAND SWITCH" in "VHF" position, adjust antenna for VHF operation and tune stage with C21 for maximum VHF output.

## TRANSMITTING CIRCUITS (Continued)

SYMPTOM	TROUBLE LOCATION	PROCEDURE
2. (Continued)	3. Third Doubler Stage V4.	1. Readjust for UHF output and tune stage by adjusting core of L4.
		2. Replace Second Doubler tube V4.
		3. Check values of R4, C8, C9, C10 and L4. Check leads for continuity or short circuits.
3. R.F. carrier OK, but no voice modulation.	1. Leads to filaments plates and screen of audio tubes.	1. Check filament voltage at Pin 5 of V1 and V8. Check plate voltage and screen voltage of V7 (Pins 1 and 7) and of V8 (Pins 2,6 and 4.) Check bias voltage at grid of V8 (Pin 3).
	2. Components of audio circuits if voltage absent or of improper value at one or more pins of V7 and V8.	1.* Check values of R16, R17, R18, C26 and C27. Check leads for continuity or short circuits.
	3. Microphone LS1.	1. Check for continuity or short circuits in LS1 and leads to T1.
	4. Input Transformer T1.	1. Check continuity of primary and secondary windings.
	5. Grid Circuit of V7.	1.* Check values of R8, R13, R15, C13, C14, C23 and C25.
	6. Speech Amplifier tube V7.	1. Check for output of V7 by connecting high impedance headphones through 0.05 capacitor between Pin 3 of V8 to ground.
		2. Replace modulator tube V8.
7. Modulator Tube V8 and Modulation Transformer T2.	1. Check for output of V8 by connecting high impedance headphones through 0.05 capacitor between Pin 2, or 6 to ground.	
	2. Repeat above test, connecting headphones and capacitor across C10. This checks secondary of transformer T2 and leads to UHF output tube.	
4. Modulation on UHF output but not on VHF output.	1. Switch S1, and connecting leads.	1. With "BAND SWITCH" S1 in VHF position, check continuity between secondary of T2 to plate, Pin 3 of V3. Check also for short to ground.

\* For RT-159A/URC-4, check resistors in comparative circuits by referring to figure 7-1A.



## TRANSMITTING CIRCUITS (Continued)

SYMPTOM	TROUBLE LOCATION	PROCEDURE
5. Voice Modulation OK but no Tone Modulation.	1. Switch S2A.	1. Check continuity across both switch contacts when switch is closed.
	2. Defective parts in audio oscillator circuits.	1. Check values of C22 and R14. Check leads from these parts for continuity, or short circuits.

## RECEIVING CIRCUITS (VHF DETECTOR)

SYMPTOM	TROUBLE LOCATION	PROCEDURE
1. Receiver does not function, VHF operation, Battery and Cable known to be in good condition.	1. Filament supply to VHF detector V5.	1. Check filament voltage at Pin 2 of V5, and leads from A+ pin of connector, through switch S1 (VHF position) to pin 2 of V5.
	2. B+ supply to VHF detector V5.	1. Check plate voltage at pin 1 of V5.
2. Check leads, also capacitors C11, C12, C13, C15, C16, C19, resistors R5, R7, R8, R12, inductors L5 and L7 for proper values and short circuits to ground.		
2. Receiver does not function, VHF operation, proper voltage at tube sockets.	1. Improper tuning of L5.	1. Tune L5 by adjusting center core to signal from test set or other transmitter. Listen to signal in pair of headphones connected between junction of C13, C14 and R8 to chassis.  2. Replace detector tube V5 and retune L5.

## RECEIVING CIRCUITS (UHF DETECTOR)

SYMPTOM	TROUBLE LOCATION	PROCEDURE
1. Receiver does not function, UHF operation, battery and cable known to be in good condition.	1. Filament supply to UHF detector V6.	1. Check filament voltage at Pin 2 of V6 and leads from A+ pin of connector through switch S1 (UHF position ) to pin 2 of V6.
	2. B+ supply to UHF detector V6.	1. Check plate voltage at pin 1 of V6.
2. Check leads, also capacitors C14, C15, C16, C17, C18, C19, resistors R6, R8, R9, and inductors L6 and L8 for proper values and short circuits to ground.		

For RT-159A/URC-4, check resistors in comparative circuits by referring to figure 7-1A.

## RECEIVING CIRCUITS (UHF DETECTOR) (Continued)

SYMPTOM	TROUBLE LOCATION	PROCEDURE
2. Receiver does not function, UHF operation, proper voltages at tube sockets.	1. Improper tuning of L6.	1. Tune L6 by adjusting center core to signal from test set or other transmitter. Listen to signal in pair of headphones connected between junction of C13, C14 and R8 to chassis.
		2. Replace detector tube V6 and retune L6.

## RECEIVING CIRCUITS (AUDIO SYSTEM)

SYMPTOM	TROUBLE LOCATION	PROCUREMENT
1. Audio Signal from detectors determined by previous tests, no output from LS1.	1. Defective resistor R8.	1. Replace R8.
	2. Defective lead to grid (pin 4) of V7.	1. Check for audio signal at grid of V7 by connecting headphones in series with 0.05 capacitor between pin 4 and ground.
	3. Defective components in grid circuit of V7.	1. Check T1, R13, R15, C23 and C25 for proper value and short circuits to ground.
	4. Defective audio Amplifier tube V7.	1. Check for audio signal with earphones and series capacitor between plate 1 and chassis. 2. Replace V7.
	5. Bias supply to V8.	1. Measure bias from pin 3 to chassis.
		2. Check R18, R11 and R10 and contacts of S2C for proper values and check circuit for continuity.
	6. Audio Output Tube V8.	1. Check for audio signal with earphones and 0.05 capacitor in series between pins 2, 6 and chassis.
		2. Replace V8.
7. Audio Output transformer T2, and loudspeaker LS1.	1. Check for audio signal with earphones across both secondary windings of T2. If signal is present across modulation winding and not across loudspeaker winding, check continuity of lead from switch S2C (switch open) through loudspeaker winding to ground. If line appears open, or shorted to ground, replace transformer.	
8. Defective loudspeaker LS1.	1. Check speaker for continuity or short.	
	2. Replace speaker LS1.	

For RT-159A/URC-4, check resistors in comparative circuits by referring to figure 7-1A.

5-8. **PERIODIC CHECKS AND PREVENTIVE MAINTENANCE.** Radio Set AN/URC-4 and battery will be checked for satisfactory operation prior to installation in any survival kit. An operational test of the AN/URC-4 Receiver-Transmitter, installed in any multiplace life raft or rescue kit, will be performed every 90 days (30 days in geographical areas where humidity conditions exist) or in conjunction with inspection requirements set forth for the life raft or rescue kit, if at shorter intervals. Inspection and testing of the BA-1264/U or BA-1315/U battery, utilized with the AN/URC-4, will be performed at the same interval as above with the following exception. In areas where the temperature falls below -65 degrees F or exceeds +110 degrees F, inspection and testing of the battery will be

performed every 30 days. Extreme caution should be employed while testing the transmitter portion of the AN/URC-4 in an effort to eliminate false transmission on the emergency frequencies.

5-9. **TESTING BATTERY.** All voltage measurements on BA-1264/U or BA-1315/U should be made with a 1,000 ohms per volt voltmeter at a temperature of approximately 80°F. To make certain the battery is in operating condition, the "A" and "B" voltages should be measured over a period of three to five minutes under load. If the voltages show a steady drop during this period of time, the battery should be replaced. In any event, the battery should be replaced if the "A" section is less than 1.18 volts under load or "B" section less than 115 volts under load.

SECTION VI

ALIGNMENT AND TESTING

6-1. GENERAL.

6-2. **ANALYZER TS-684/URM-30.** This analyzer has been specifically developed for alignment and testing of Radio Set AN/URC-4. Complete alignment procedures for use of this analyzer are contained in the handbook covering its operation.

6-3. **EMERGENCY ALIGNMENT WITHOUT ANALYZER TS-684/URM-30.**

6-4. Radio Set AN/URC-4 may be aligned without the analyzer when circumstances make it necessary. Figure 6-1 shows a simple test circuit for aligning the transmitting circuits that may be made from parts normally found in the maintenance depot. It consists of a 0-1 milliammeter, a shunting capacitor, a 1N34 crystal rectifier and a piece of twisted hook-up wire approximately 17 inches long, terminated in a loop approximately 3/4 inch in diameter.

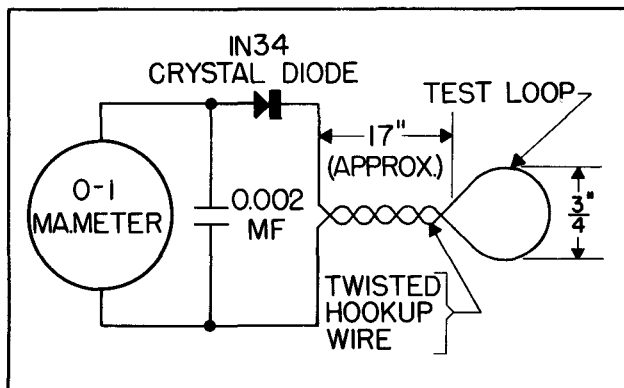

Figure 6-1. Schematic of Test Circuit for Emergency Alignment

6-5. The procedure for aligning the r.f. circuits of the transmitter is as follows:

a. Remove the cover from the receiver-transmitter case.

b. Place the pick-up coil of the analyzer around the plate tank coil of the crystal oscillator. Adjust controls and antenna for UHF operation.

c. Using a non-inductive, low-capacity tuning tool, rotate the core of L1 for reading of the meter.

d. Repeat for L2, L3, and L4.

e. Couple the coil loosely to the antenna and repeat tuning of L1, L2, L3 and L4 for maximum deflection of the meter, moving the pick-up coil farther from the antenna as the signal strength increases.

f. Adjust the controls for VHF operation.

g. Couple the loop to the antenna and tune C-21 for maximum deflection of the meter.

h. Replace cover on case of the receiver-transmitter.

6-6. The procedure for aligning the receiver circuits is as follows:

a. Remove cover from the case and adjust the controls for VHF receiving condition.

b. Adjust a signal generator to the proper frequency, or use the signal from another transmitter for alignment. If a signal generator is used, connect the output leads between the case and insulated vertical antenna section and adjust for 300 microvolts, 30% modulated with a 1,000 cycle tone. If another transmitter-receiver is employed, locate it some distance away from the unit being aligned. If the signal is too strong, collapse the antenna of the receiver-transmitter being used as a signal generator. Adjust it for locked tone modulation.

c. Reduce the value of the signal from the signal generator or receiver transmitter until a sharp tuning point is observed while listening to the output of the unit being aligned.

d. Tune L5 for maximum output, reducing the strength of the signal until a sharp peak is obtained.

6-7. The procedure for aligning the UHF circuits is the same as for the VHF circuits, using a signal of proper frequency and aligning L6 in the manner explained in paragraph 6-5.

## SECTION VII

## DIAGRAMS

Figure No.	Title	Page No.
7-1.	RT-159/URC-4, Schematic Diagram . . . . .	21
7-1A.	RT-159A/URC-4, Schematic Diagram . . . . .	22
7-2.	RT-159/URC-4, Practical Wiring Diagram . . . . .	23
7-2A.	RT-159A/URC-4, Wiring Diagram . . . . .	24
7-3.	Terminal Voltage and Resistance Diagram, R.F. Sub- Chassis . . . . .	25
7-4.	Terminal Voltage and Resistance Diagram, Detector and Audio Circuits . . . . .	26
7-5.	RT-159/URC-4, Terminal Board Voltage and Resistance Diagram . . . . .	26
7-6.	RT-159A/URC-4, Terminal Board Voltage and Resistance Diagram . . . . .	26

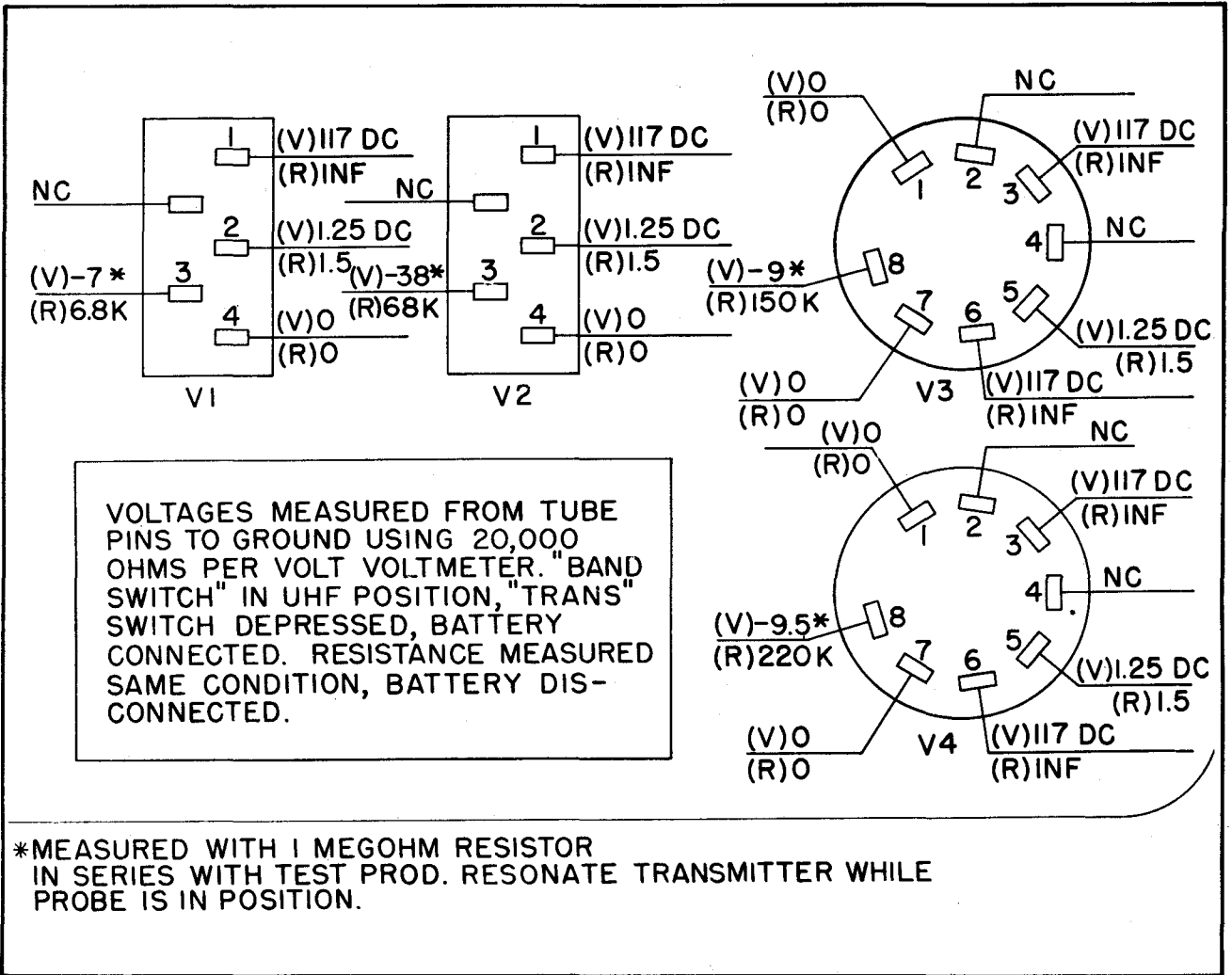

Figure 7-3. Terminal Voltage and Resistance Diagram, R.F. Sub-Chassis

TABLE 7-1

Changed values in Tubes V1 through V4 for RT-159A/URC-4. (All values shown in figure 7-3 are valid for RT-159A/URC-4, except as indicated below.)

Tube	Terminal	Voltage	Resistance
V1	1	102	
	3	-6	56K
V2	1	108	
	3		50K
V3	3	112	
	6	114	
V4	8	-50	270K
	3	114	
	6	114	
	8	-35	

TABLE 7-2

Changed values in Tubes V5 through V8 for RT-159A/URC-4. (All values shown in figure 7-4 are valid for RT-159A/URC-4, except as indicated below.)

Tube	Terminal	Voltage	Resistance
V5	3	-8	
V6	1	88	
	3	-9	
V7	1	22	
	2	14	
V8	2	107	
	4	115	
	6	NC	NC

*222 ohm for 10V Drop @ 45mA 4.5 Watts.  
9.15 ohm for 3.75V Drop @ 520mA.*

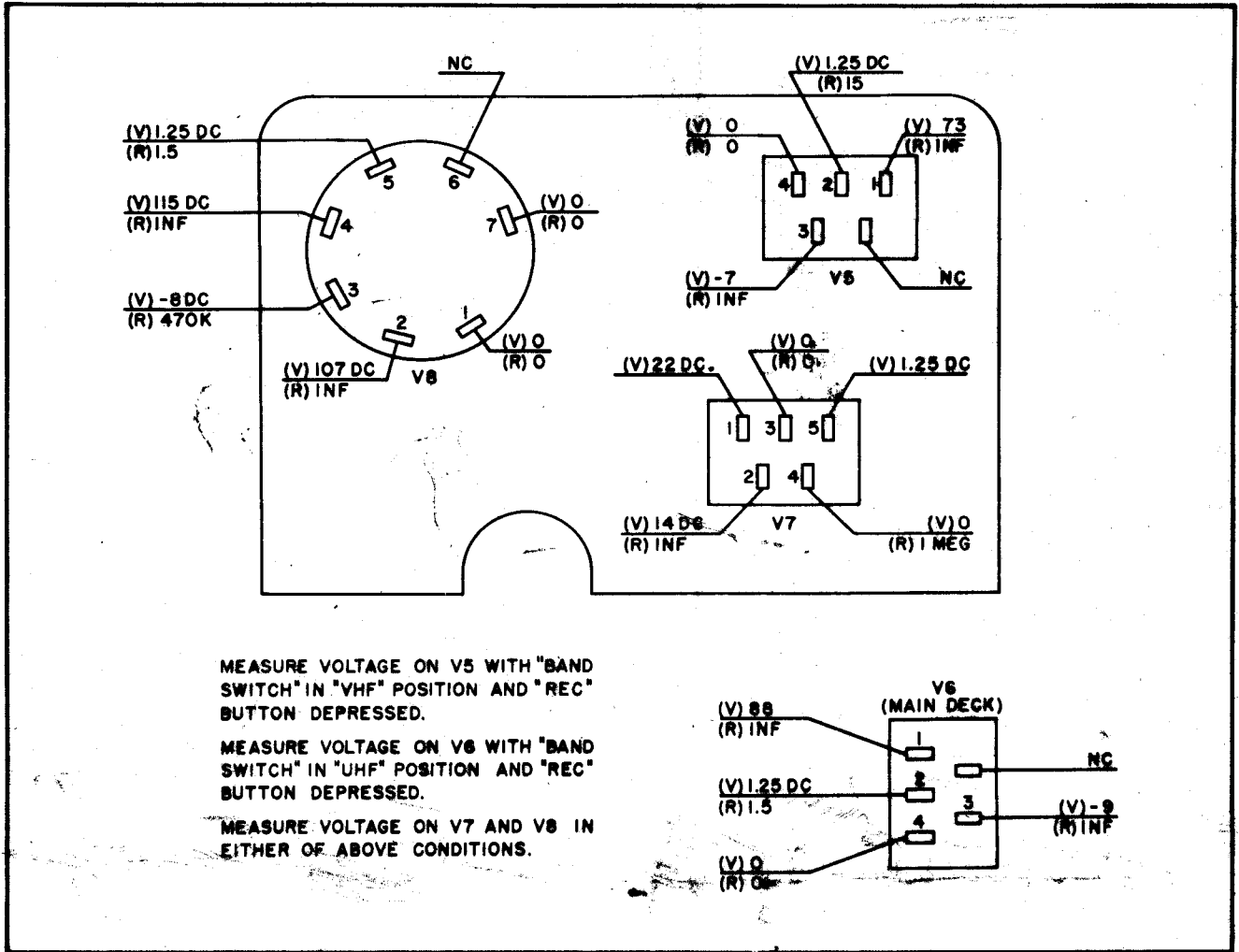

Figure 7-4. Terminal Voltage and Resistance Diagram, Detector and Audio Circuits

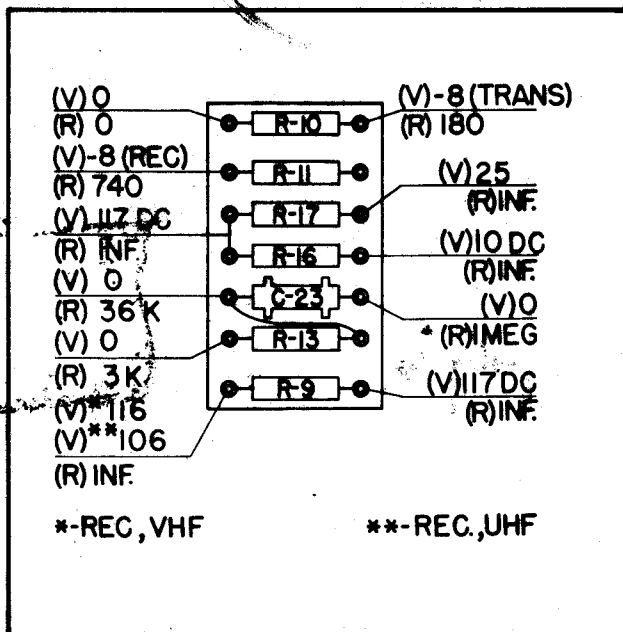

Figure 7-5. RT-159/URC-4, Terminal Board Voltage and Resistance Diagram

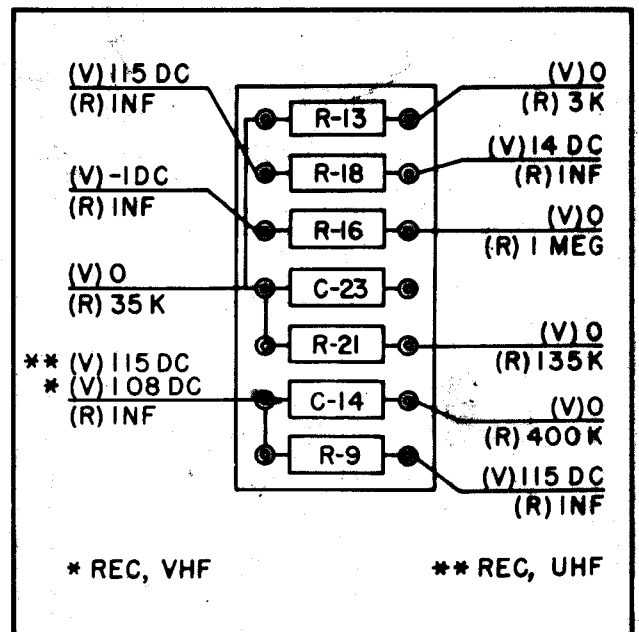
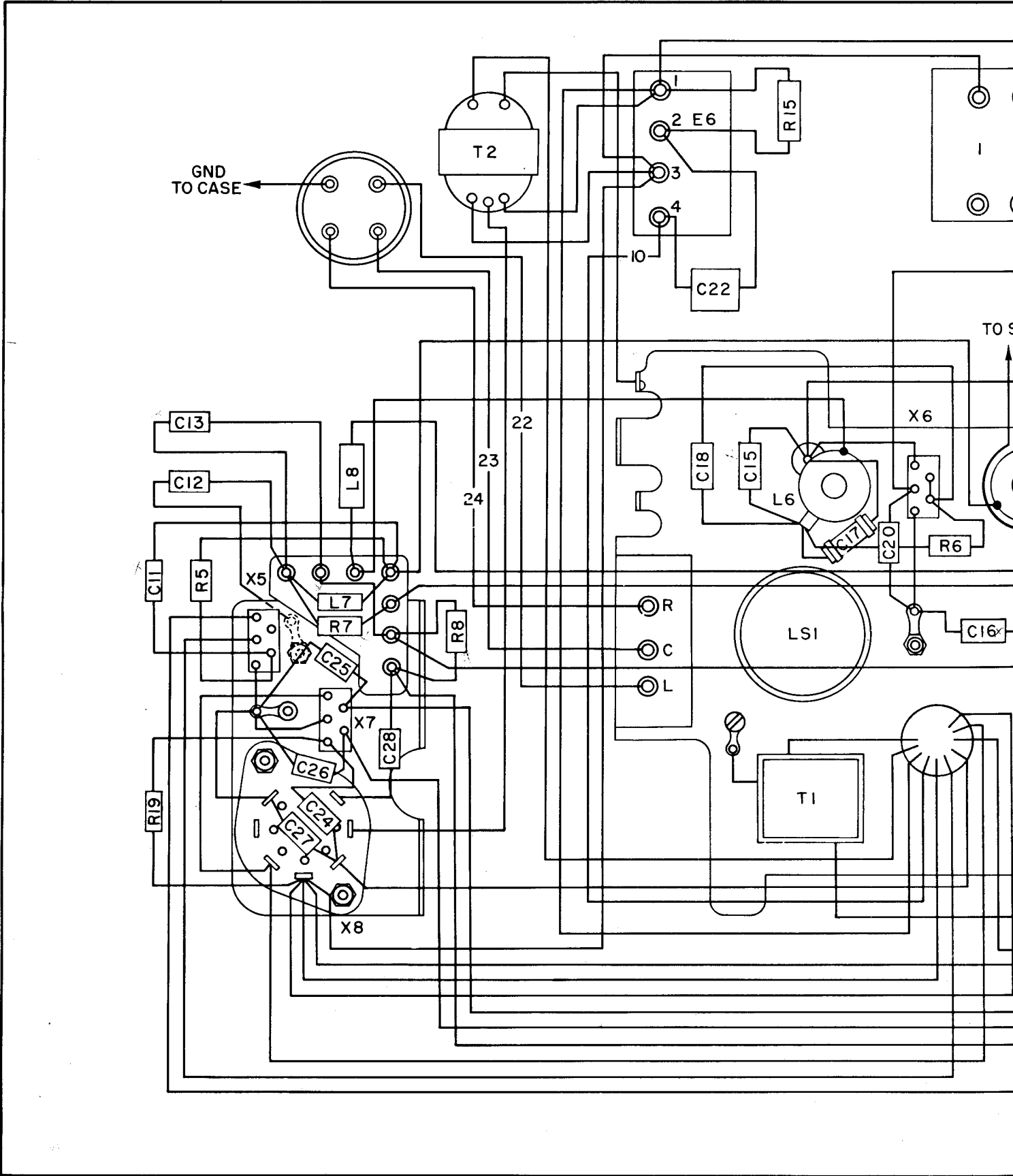
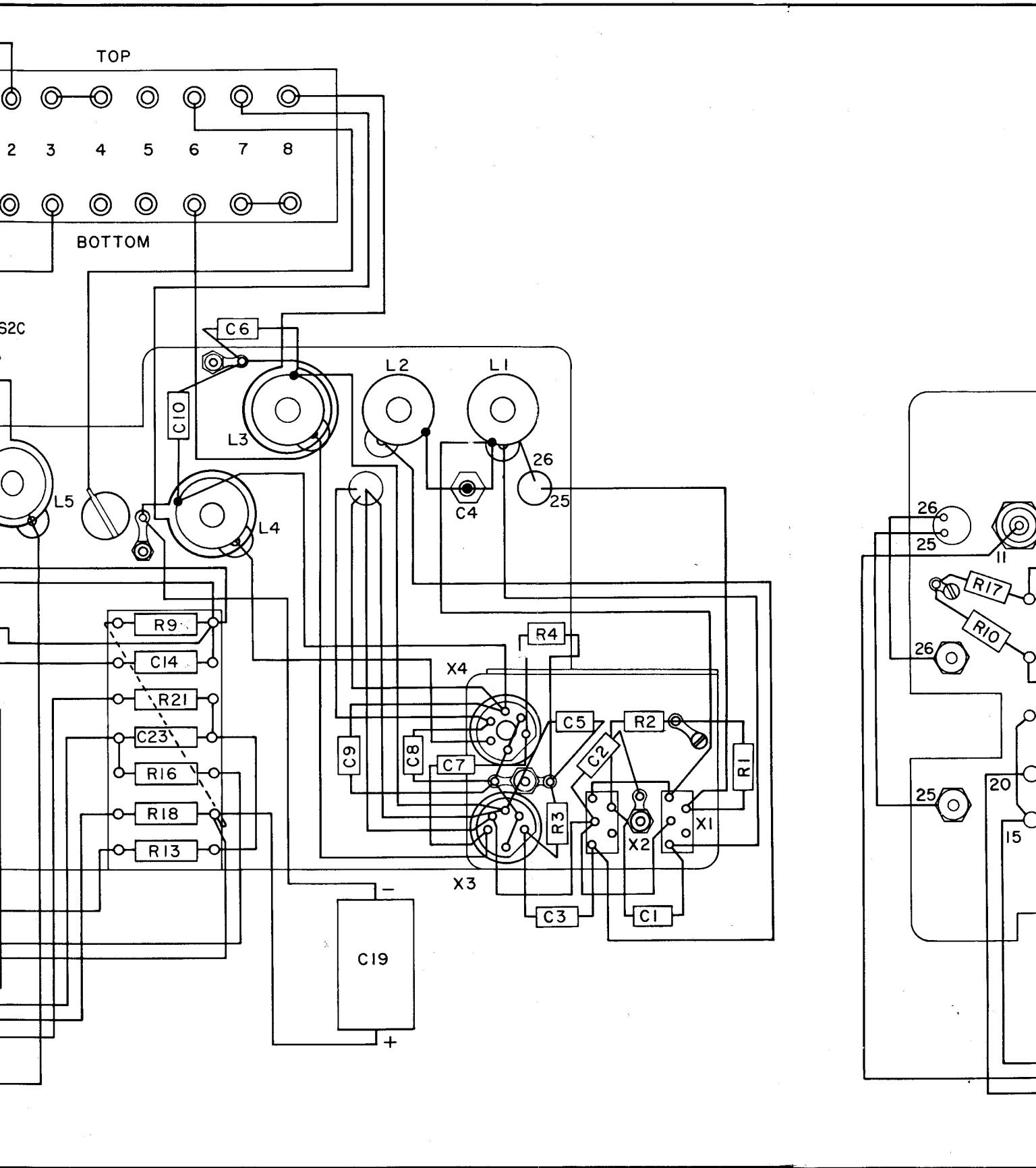

Figure 7-6. RT-159A/URC-4, Terminal Board Voltage and Resistance Diagram











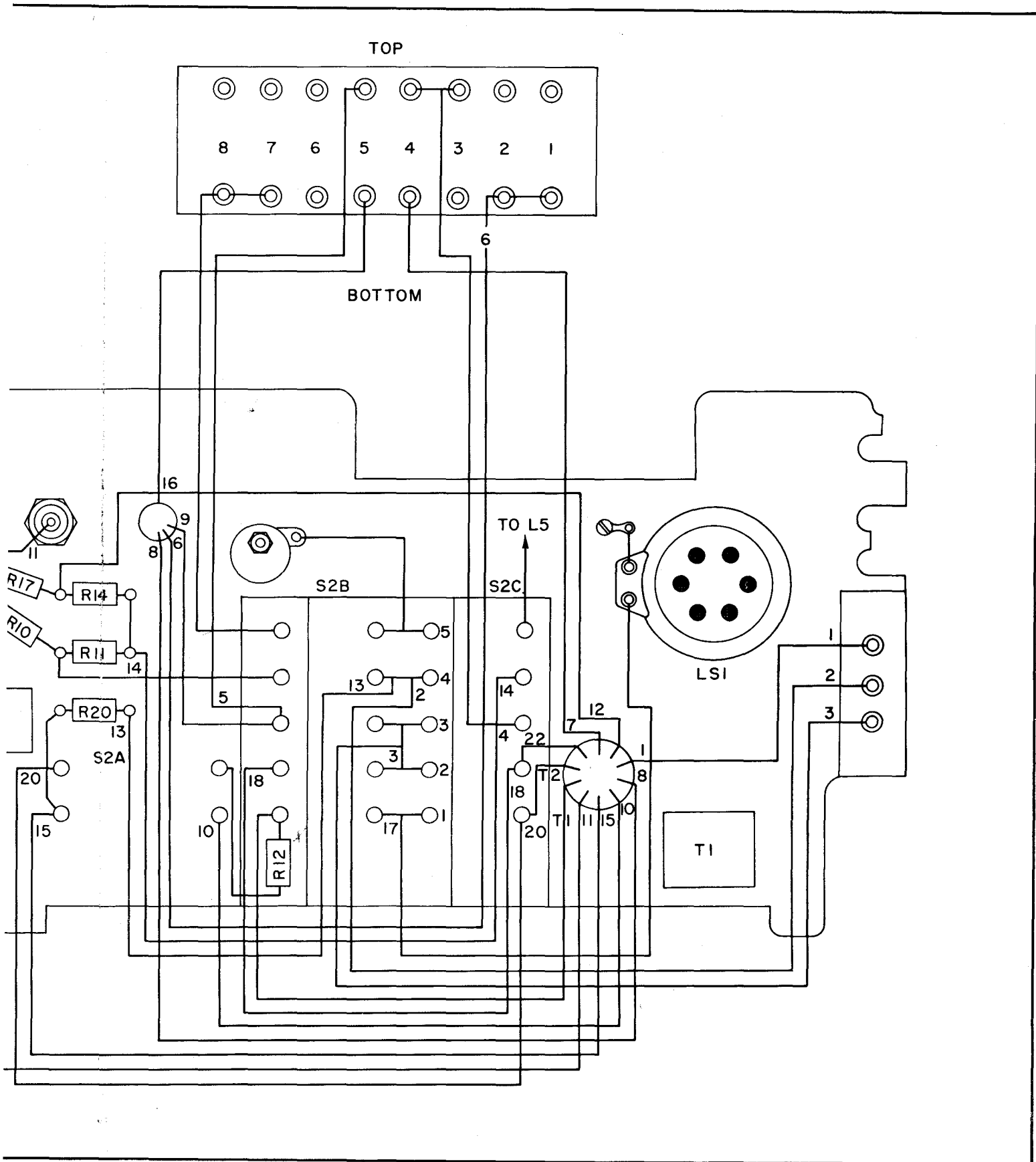
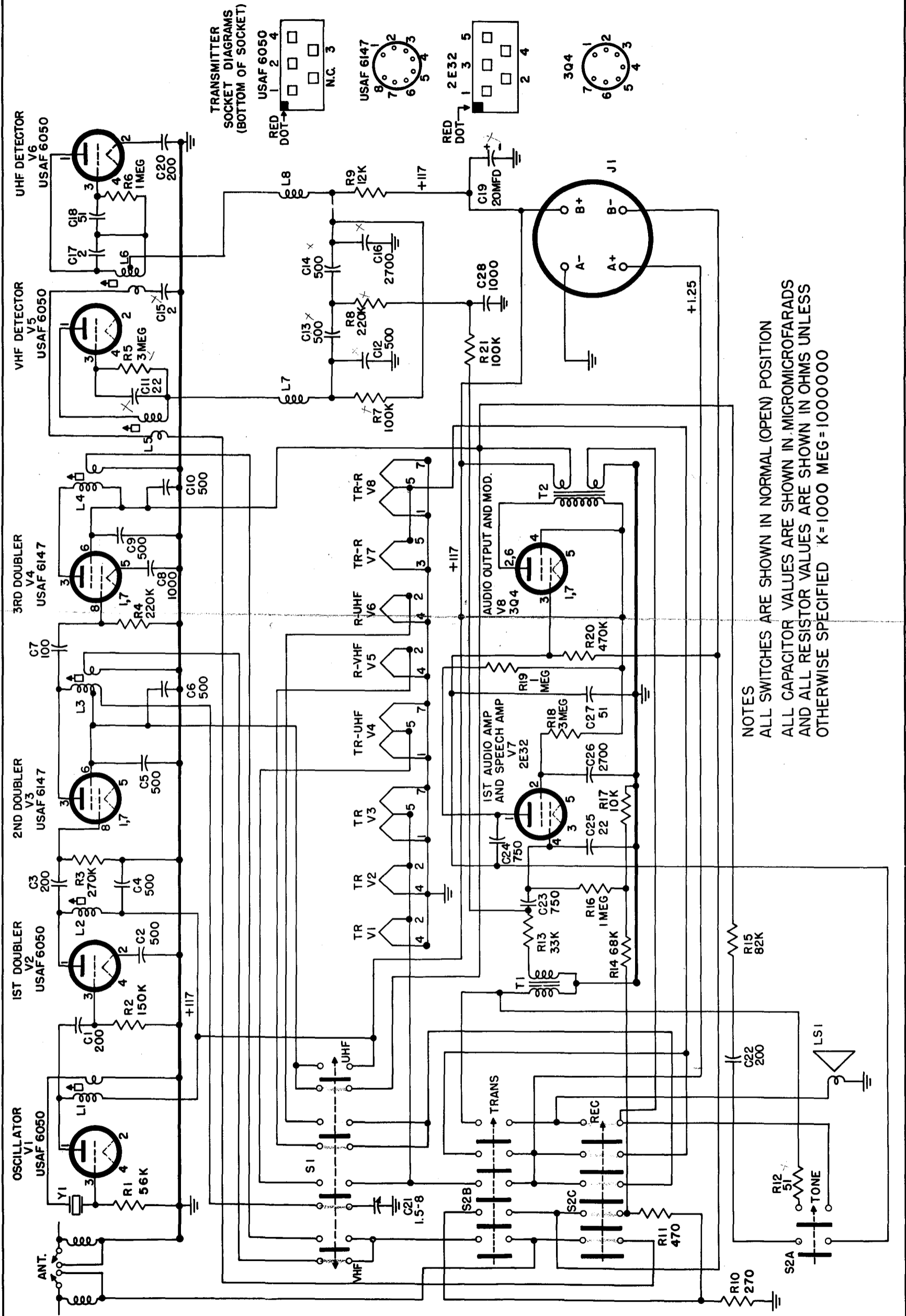

Figure 7-2A. RT-159A/URC-4, Wiring Diagram





NOTES  
 ALL SWITCHES ARE SHOWN IN NORMAL (OPEN) POSITION  
 ALL CAPACITOR VALUES ARE SHOWN IN MICROMICROFARADS  
 AND ALL RESISTOR VALUES ARE SHOWN IN OHMS UNLESS  
 OTHERWISE SPECIFIED K=1000 MEG=1000000

Figure 7-1A. RT-159A/URC-4, Schematic Diagram

Revised 1 July 1952

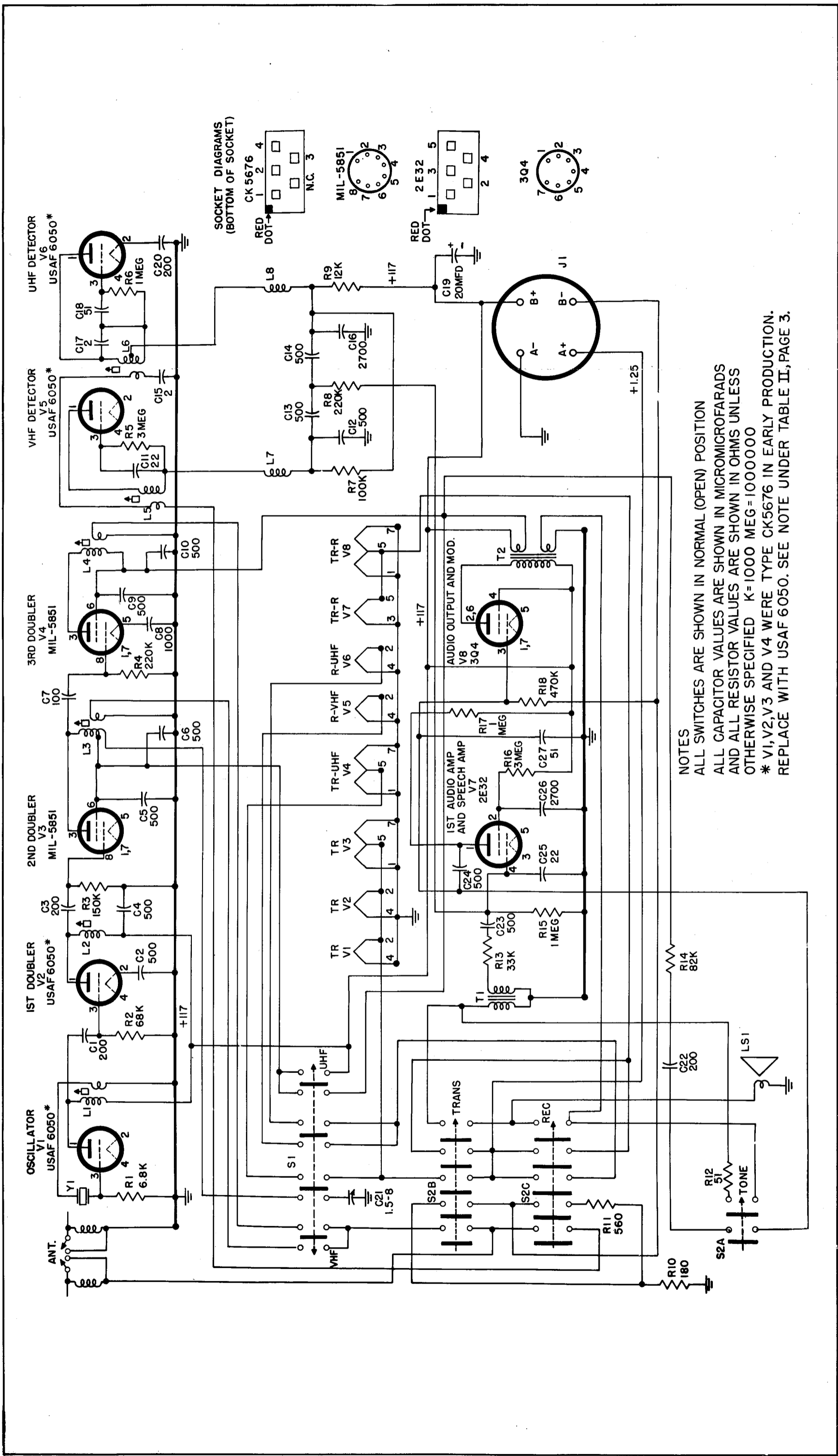

NOTES  
 ALL SWITCHES ARE SHOWN IN NORMAL (OPEN) POSITION  
 ALL CAPACITOR VALUES ARE SHOWN IN MICROMICROFARADS  
 AND ALL RESISTOR VALUES ARE SHOWN IN OHMS UNLESS  
 OTHERWISE SPECIFIED K=1000 MEG=1000000  
 \* V1, V2, V3 AND V4 WERE TYPE CK5676 IN EARLY PRODUCTION.  
 REPLACE WITH USAF 6050. SEE NOTE UNDER TABLE II, PAGE 3.

Figure 7-i. RT-159/URC4, Schematic Diagram