

# Technical manual

## TA. 940B 100 Watt Linear Amplifier



**RACAL**  
THE ELECTRONICS GROUP

**Racal-Mobilcal Limited** 464 Basingstoke Road, Reading, Berks. RG2 0RY England  
Tel. Reading 84461 or 85571 Telex. 847152 Grams: RACMOBILCAL READING  
Prepared by Technical Publications, Racal Group Services Limited.  
Printed in England

Ref. WOH 1122

Issue 7.2.74-200



THIS HANDBOOK REFERS TO EQUIPMENT  
SERIAL NUMBER ..... AND SUBSEQUENT

### HANDBOOK AMENDMENTS

See Yellow Amendment Sheet Numbers .....  
which follow this page. The action called for by the amendments  
should be carried out by hand as soon as possible.



RACAL-MOBILCAL LIMITED, READING

AMENDMENT TO

TA.940B 100 WATT LINEAR AMPLIFIER

Chapter 1 - Page 1-1

Para. 4.

Amend to read: "Mounting frames type 989 .....". "These frames can ....."

Chapter 6 - Page 6-1

Para. 1 - Amend to read:

"This Chapter details the procedures for adjusting the input level and the collector current detector preset controls. Access to these controls is obtained by removing the case from the rear of the unit (See Chap. 5)".

Heading of Para. 3

Amend to read: Use of Test Set CA.470B

Components List

Page 8-7

Delete D13, D14, D15, D16. Not used.

Page 8-8

Amend PLA Part Number to read: 917789.

Page 8-9

Amend LP1 Part Number to read: 920892.

ILLUSTRATIONS

Fig. 7. Insert after D10 and D11 Type Number IN4149.

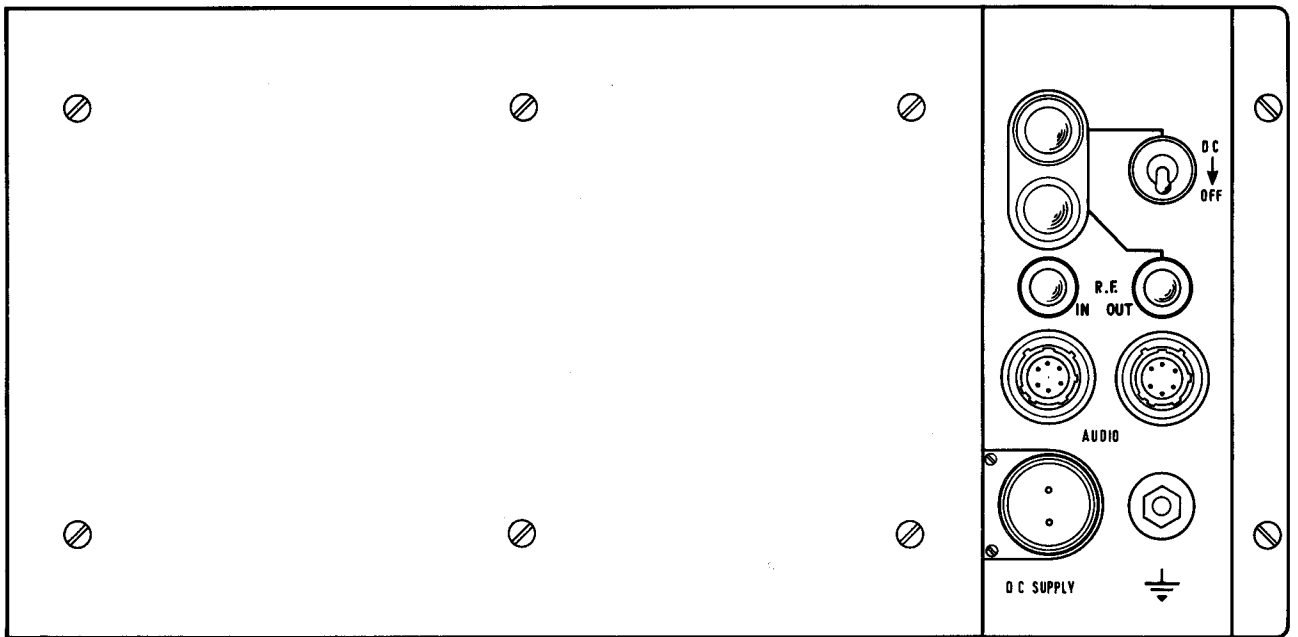

WOH1122

## 100W Linear Amplifier Type TA.940B

# 100W LINEAR AMPLIFIER TYPE TA.940B

## CONTENTS

		<u>Para</u>
	TECHNICAL SPECIFICATION	
CHAPTER 1	GENERAL DESCRIPTION	
CHAPTER 2	INSTALLATION INSTRUCTIONS	
	Preliminary Procedures	1
	Installation Procedures	2
	Cable Assemblies	3
CHAPTER 3	OPERATING INSTRUCTIONS	
	Introduction	1
	Tuning	2
	Operating	3
	Frequency Changing	4
CHAPTER 4	CIRCUIT DESCRIPTION	
	Power Supply and Relay Circuits	1
	R.F. Input	6
	Pre-Driver	7
	Driver	8
	Power Amplifier	9
	R.F. Output	13
	Antenna Current Transformer	14
	A.L.C. Controlled Stage	15
	Collector Voltage Detector	19
	Collector Current Detector	20
CHAPTER 5	DISMANTLING AND RE-ASSEMBLY	
	Rear Cover Removal	1
	Low Level Board Removal	2
	High Power Board Removal	3
	Re-Assembly	4
CHAPTER 6	ADJUSTMENTS	
	Introduction	1
	Test Equipment	2
	Use of Test Set CA.470B	3
	Procedures	6
	Setting to suit Input Level	7
	Setting for 1W or 5W Input	8

## CONTENTS (continued)

CHAPTER 6 (cont'd)		<u>Para.</u>
	Setting for 100mW Input	9
	Setting of Collector Current Detector	10
CHAPTER 7	FAULT LOCATION	
	Introduction	1
	Test Equipment	3
	Initial Fault Location	4
	General Fault Location	7
	Supply Checks	10
	R.F. Checks	11
	High Power Board	12
	Low Level Board	13
	Table 1 Typical R.F. Signal Levels	
	Table 2 Typical D.C. Voltage Levels	

CHAPTER 8	COMPONENTS LIST
-----------	-----------------

### ILLUSTRATIONS

Frontispiece	100W Linear Amplifier Type TA.940B
Fig. 1	Test Connections
Fig. 2	Block Diagram
Fig. 3	Plan and side views with cover removed
Fig. 4	Underside of Power Board Mounting Plate
Fig. 5	Component Layout: Low Level Board
Fig. 6	Component Layout: Power Board
Fig. 7	Circuit: 100W Linear Amplifier TA.940B



## TECHNICAL SPECIFICATION

Frequency Range:	1.6 - 30 MHz.
Input:	5 watts p.e.p. $\pm$ 3dB into 50 ohms unbalanced. (100 mW or 1 watt to special order).
Power Output at an ambient temperature of 25°C:	S.S.B. (A3A, A3J) 100 watts p.e.p. nominal. D.S.B. (A2, A3) 25 watts carrier approximately. F.S.K. (F1) 100 watts mean nominal. C.W. (A0) 100 watts nominal. Minimum power not less than 1dB down with reference to nominal.
Output Impedance:	50 ohms unbalanced.
Variation with Temperature:	Less than $\pm$ 1dB over the full temperature range.
Duty Cycle:	The amplifier will operate continuously at full power output, (A0 mode) at an ambient temperature of +25°C.
Harmonics:	Each harmonic better than -40dB relative to full p.e.p. into 50 ohms at the output of the associated A.T.U.
Intermodulation Products:	Odd order products better than -25dB relative to each tone of the standard 2-tone test at full p.e.p. into 50 ohms.
Environmental:	The amplifier is housed in a sealed, desiccated immersion-proof case.
Power Supply:	28 volts d.c. 11 amps. (negative earth), The amplifier may be used over the range 24 - 30V with a degraded performance at the lower voltages.
Temperature Range:	Operating - 10°C to + 55°C Storage - 40°C to + 70°C
Dimensions:	Width: 359 mm (14.1 ins) Height: 167 mm (6.6 ins) Depth: 225 mm (8.9 ins)
Weight:	8.9 kg (19.5 lb).

## CHAPTER 1

### GENERAL DESCRIPTION

1. The Linear Amplifier Type TA.940B has a frequency range of 1.6 MHz to 30 MHz. The amplifier provides a power output of approximately 100 watts p.e.p. into a 50 ohm load from the transmitter output of a Transmitter-Receiver Type TRA.906, TRA.921, TRA.922, TRA 931, or TRA 932.
2. The amplifier may be used for field operation with a separate 28 volt nickel-cadmium battery MA.941. A battery charger MA.945 is also available.
3. The amplifier can also be used for vehicle or shipborne installations with an MA.936 power unit fed from a 12V or 24 Volt d.c. supply. For installations where an a.c. power supply is available an MA.935 a.c. power unit, which includes an audio amplifier and a loudspeaker, can be supplied.
4. Mounting Trays Type MA.946 are available for use with this unit, the transmitter-receiver and the power unit. The trays can be either joined and the units mounted one above another, or separated and the units mounted individually as required.
5. The output to the antenna must be fed via an MA.942 or MA.975 antenna tuning unit, which can be supplied as an accessory.
6. The TA.940B amplifier utilises all solid state devices and embodies an adequate heat sink for the power transistors and thermostatic protection against excessive temperature rise. The unit is fully waterproof and can be totally immersed for an indefinite period. De-humidifying of the amplifier is achieved by the inclusion of a desiccator unit, which can be replaced or re-conditioned without breaking the main seal on the unit.

## CHAPTER 2

### INSTALLATION INSTRUCTIONS

#### PRELIMINARY PROCEDURES

1. Before making any connections to the TA.940B amplifier check that the amplifier, transmitter-receiver and power unit, if used, are all switched off.

#### INSTALLATION PROCEDURES

NOTE: These procedures cover connections to either the battery or power unit with the standard cable assemblies provided.

2. (1) Connect the coaxial cable CA.700664/B between the TA.940B R.F. OUTPUT socket and the INPUT to the Antenna Tuning Unit.
- (2) Connect the second coaxial cable CA.700664/A between the TA.940B R.F. INPUT socket and the appropriate 50Ω socket on the transmitter-receiver, dependant upon the operating frequency.
- (3) Connect one of the leads CA.700665/A, terminated with 6-way Thorn Pygmy plugs at each end, into one of the two AUDIO sockets on the transmitter-receiver and plug the other end into one of the two AUDIO sockets on the TA.940B.
- (4) Connect the CA.700663/A lead, terminated with a 2-way plug and a 2-way socket, from the battery or power unit to the 2-pin plug on the TA.940B.
- (5) Connect all earth terminals to earth. These connections should be as short as possible, be of either stout wire or braid and in vehicle installations must be bonded to the vehicle earth to minimise ignition interference.
- (6) When a power unit MA.935 is used in the installation, connect the second CA.700665/A lead, terminated with 6-way Thorn Pygmy plugs, between an AUDIO socket on the MA.935 and the remaining AUDIO socket on the amplifier.
- (7) Connect the handset or morse key to the remaining AUDIO socket on the transmitter-receiver.

Para. 2 cont'd

NOTE: In instances where both the handset and key will be required, the key can be connected to the remaining AUDIO socket on either the amplifier, when the battery is being used, or to the Power unit when it is used.

(8) Affix the adhesive label AR 711105 (supplied with the TA.940B) to the front of the transmitter-receiver, so that TUNE on the label corresponds to the HIGH position of the Power switch. The label is only required when a TRA.921 or TRA.922 is in use.

(9) Connect the antenna to the terminal at the front of the Antenna Tuning Unit. The antenna may be a whip, a long wire or a dipole. In the case of the dipole, the screen of the feeder should be connected to the earth terminal at the front of the A.T.U. High voltages will be present on the antenna during transmission and it should be erected in a position where it can not be accidentally touched.

NOTE: The equipment is normally supplied adjusted to accept a 5W (nominal) input from the associated transmitter-receiver. If a different input level is to be used refer to Chap. 6.

CABLE ASSEMBLIES

3. A list of the interconnecting cables normally provided with the amplifier is given below, together with their standard length and the maximum length to which they may be extended.

<u>Cable</u>	<u>Quantity</u>	<u>Standard Length</u>	<u>Maximum Length</u>
CA.700663/A (2-way)	1	1 metre	2 metres
CA.700664/A (coaxial)	1	1 metre	10 metres
CA.700664/B (coaxial)	1	2 metres	4 metres
CA.700665/A (6-way)	2	1 metre	1 metre

## CHAPTER 3

### OPERATING INSTRUCTIONS

#### INTRODUCTION

1. The transmitter-receiver and the amplifier must be connected-up as described in the preceding Chapter.

WARNING: DANGEROUS VOLTAGES ARE PRESENT ON THE ANTENNA DURING TRANSMISSION AND CAUTION MUST BE EXERCISED TO AVOID CONTACT WITH THE ANTENNA AND ITS ACCESSORIES.

#### TUNING

2. (1) Set the D.C. switch on the amplifier to ON and the POWER switch on the power unit, if used, to ON.  
(2) Check that the D.C. ON indicator lamp on the amplifier is illuminated.  
(3) Select the required frequency on the transmitter-receiver and check that the coaxial cable from the amplifier is connected to the correct 50Ω socket on the transmitter-receiver for the frequency selected.  
(4) On either the TRA.921 or TRA.922, set the HIGH-LOW POWER switch to HIGH.  
(5) Set the Mode switch on the transmitter-receiver to TUNE.  
(6) Depress either the handset Press-to-Talk switch or the key and adjust the TUNE control on the transmitter-receiver for a maximum reading on the meter.  
(7) With the P.T.T. switch or key still depressed, adjust the Antenna Tuning Unit for a maximum current on its meter.  
(8) On the amplifier, check the the R.F. OUTPUT indicator is illuminated.

#### OPERATING

3. (1) On either the TRA.921 or TRA.922 set the HIGH-LOW POWER switch to LOW POWER.

Para. 3 cont'd

- (2) Set the Mode switch to the desired mode and use the handset or key as required.

CAUTION: The amplifier must not be operated with HIGH POWER selected at the TRA.921 or TRA.922.

- (3) If the 100 watt output is not required, the normal power output from the transmitter-receiver is obtained by setting the TA.940B D.C. switch to OFF. In this condition the HIGH POWER output of the TRA.921 or TRA.922 can be used if required.

FREQUENCY CHANGING

4. To change to new channel frequency, repeat the tuning and operating procedures given in operations 2 (3) to 3 (2).

## CHAPTER 4

### CIRCUIT DESCRIPTION

#### POWER SUPPLY AND RELAY CIRCUITS

1. The amplifier requires a 28 volt d.c. supply, which is applied via the POWER switch SA and filter circuit comprising a choke L2 and capacitors C48 and C53. Protection is provided against reverse polarity connections by zener diode D20, which, under these conditions, produces a short circuit across the supply to blow fuse FS1. The 28 volt supply is not applied to all the amplifier stages unless all three relays RLA/2, RLB/2, and RLC/1 are energized.
2. Relay RLC/1 is energized when the external press-to-talk pressel switch is closed, which energises, in turn, relays RLB/2 and RLA/2. The thermal cut-out X1 provides overheat protection. If overheating occurs the cut-out opens and de-energises RLB/2 and RLA/2.
3. When relays RLB/2 and RLA/2 are in the de-energized condition, contacts RLB-1 and RLA-1 break the +28 volts supply to all the low power stages, and also to the biasing circuits for the driver and power amplifier, preventing emission from the amplifier. Under these conditions the r.f. output from the manpack is fed directly to the amplifier r.f. output socket SKD, via contacts RLA-2 and RLB-2.
4. When relays RLB/2 and RLA/2 are energized, contacts RLB-1 and RLA-1 apply the +28 volts to all the stages and biasing circuits. Contact RLA-2 applies the r.f. input to the amplifier and contact RLB-2 connects the amplifier output to the r.f. output socket SKD.
5. To prevent the immediate de-energization of relay RLC when the morse key is released resistor R77 and capacitors C54, C56, C58 and C60, are connected across relay RLC and diode D22 to provide the required delay.

#### R.F. INPUT

NOTE: The description in the remainder of this Chapter assumes that relays RLA/1, RLA/2 and RLC/2 are in the energized condition unless otherwise stated.

6. The r.f. input at socket SKC is fed via relay contact RLA-2 and link LK2 (1-5W input) to resistors R25, R26, R24, R27 which attenuate the input prior to it being fed to transistors TR8, TR9 in the a.l.c. controlled stage. Transistors TR8 and TR9 operate in a grounded base push-pull mode and are transformer coupled, by transformers T3 to T7, to the pre-driver stage.

## PRE-DRIVER

7. The pre-driver stage has four transistors, TR1, TR2, TR3 and TR4 operating in class A as two push-pull pairs in grounded base mode. The base bias for these transistors is provided by potential divider R5, R8 and R14 with diodes D4 and D5 providing temperature compensation. Transformer T1 provides coupling to T13, T14, T17 and T18 in the driver stage.

## DRIVER

8. The driver is a class B push-pull stage utilizing transistors TR18 and TR19 in a grounded base configuration. The biasing circuit for the bases of these transistors is similar to that in the pre-driver stage. The stage is coupled to the power amplifier by transformer T15.

## POWER AMPLIFIER

9. Four pairs of transistors, TR5, TR6; TR11, TR16; TR20, TR21; TR22 and TR23, operated in class B as push-pull pairs in the common emitter mode, form the power amplifier.

10. The base biasing for the transistors is obtained from the two potential dividers R1 to R4 and D1, R85 to R88 and D25; diodes D1 and D25 providing temperature compensation. Diodes D2 and D24 are included to limit the maximum voltage under fault conditions.

11. Two parallel connected transformers T9 and T22 couple the output from the power amplifier. Two transformers are used to reduce transistor-transformer connection lengths to a minimum.

12. Negative feedback is applied over the power amplifier, by resistors R21, R40, R67, and R75, to provide a reasonably linear response over the frequency range.

## R.F. OUTPUT

13. The output from the power amplifier transformers T9 and T22 is fed to socket SKD via the v.s.w.r. detector transformer T16, relay contacts RLB-2 and the antenna current transformer T23.

## ANTENNA CURRENT TRANSFORMER

14. Transformer T23 produces a voltage across resistor R78 which illuminates the clear indicator lamp LP1 when an r.f. output is supplied.



## A.L.C. CONTROLLED STAGE

15. This stage controls the r.f. input level applied to the pre-driver, and obtains its control voltage from the collector voltage detector and collector current detector, (paras. 19 and 20). The overall effect of the stage is to provide a sensibly constant output level from the p.a. by controlling the input level to the pre-driver.
16. The control voltage input from the two detectors is fed into the a.l.c. stage from the junction of D11 and TR12 via the emitter follower TR12, TR13. Capacitor C22 and resistor R30, provide the required slow decay time of the a.l.c. system.
17. Transistors TR14 and TR15 provide a reference voltage for the bases of transistors TR8 and TR9. The gain of transistors TR8 and TR9 is controlled by the voltage at the bases of TR7 and TR10. When the voltage at the base of transistors TR7 and TR10 exceeds the reference voltage, the voltage at the emitter of TR7 and TR10 will rise, starving the current flow through TR8 and TR9 and reducing the input level applied to the pre-driver stage. Diodes D7 and D10 protect the a.l.c. stage by limiting the applied voltage.
18. The output of the stage is fed to the pre-driver via transformers T3 to T7. Resistor R24 sets the threshold level of the stage.

## COLLECTOR VOLTAGE DETECTOR

19. The collector voltage circuit includes one transistor TR17. Under normal conditions this transistor conducts as the voltage at its base is above approximately 7 volts, i.e. the level determined by the reference zener diode D12. If the power amplifier collector voltages (TR5 to TR23, see para. 9) drop below 7 volts, diodes D3, D6, D19 and D23 conduct and turn off transistor TR17, causing the voltage at its collector to increase. This increased voltage is applied to the a.l.c. controlled stage via D11. Diodes D27 and D28 protect TR17 against reversed polarity.

## COLLECTOR CURRENT DETECTOR

20. The Collector Current Detector monitors the d.c. collector current in the power amplifier transistors and applies a control voltage to operate the a.l.c. stage when the power amplifier collector current exceeds a pre-determined level.
21. Transistor TR24 monitors the collector current of TR5, TR6, TR11 and TR16 is one half of the power amplifier whilst TR26 monitors the collector current of TR20, TR21, TR22 and TR23 in the other half of the power amplifier. Transistor TR25 sets the reference voltage for TR24 and TR26.
22. The voltage developed across R93 and R97 is proportional to the collector current of TR5, TR6, TR11 and TR16; if this collector current increases sufficiently for the voltage developed across R93 and R97 to exceed the reference voltage set by TR25, transistor TR24 will conduct and apply a control voltage to the a.l.c. stage, thereby reducing the input to the pre-driver stage.

23. Similarly, the voltage developed across R97 and R101 is proportional to the collector current of TR20, TR21, TR22 and TR23; transistor TR26 will conduct if the voltage across R97 and R101 exceeds the set by TR25 and again apply a control voltage to the a.l.c. stage.

## CHAPTER 5

### DISMANTLING AND RE-ASSEMBLY

#### REAR COVER REMOVAL

1. Remove the twelve fixing screws in the flange of the rear cover and lift the cover off to expose the low level and high power boards.

#### LOW LEVEL BOARD REMOVAL

2. (1) Unsolder the leads connected to pins B1, B2 and B3. Figure 5 shows the position of these pins.  
(2) Remove the eight screws securing the board to its mounting plate.  
(3) Progressively ease transistors TR1 to TR4 out of their retaining clips on the mounting plate.  
(4) The underside of the board will now be accessible for changing components by hinging the board back on its cable form.

#### HIGH POWER BOARD REMOVAL

3. (1) Unsolder the leads connected to pins B1, B2 and B3 of the low level board (see Fig. 5).  
(2) Remove the four screws securing the low level board mounting plate to the pillars.  
(3) Hinge the low level board and its mounting plate back on its cableform to expose the high power board.  
(4) Unsolder all connections to the high power board (2-coaxial cable and 10-wires) noting their respective positions.  
(5) Release the ten captive screws securing the high power board mounting plate to the heat sink and lift the assembly off. Wipe off the heat conducting compound from the heat sink and mounting plate.

#### RE-ASSEMBLY

4. The re-assembly procedures are the reverse of the dismantling operations given above, but the following points should be noted when replacing the power board mounting plate.

Para. 4 cont'd

- (1) Ensure that all swarf and foreign matter is removed from the mating surfaces and adjacent areas.
- (2) Ensure that the connections to the transistors and resistors on the mounting plate will be clear of metallic surfaces when the plate is assembled.
- (3) Lightly smear mating faces with an even film of THERMAFLOW A30/J compound.

## CHAPTER 6

### ADJUSTMENTS

#### INTRODUCTION

1. This chapter details the procedures for adjusting the input level, v.s.w.r. balance and v.s.w.r. sensitivity pre-set controls. Access to all three controls is obtained by removing the case from the rear of the unit. (See Chap. 5).

NOTE: Incorrect setting-up or the use of inaccurate instruments may result in the protection circuits not being fully effective.

#### TEST EQUIPMENT

2. The following test equipment is required to carry out the procedures:-

- (a) 5 watt R.F. source. The associated Racal Transmitter-Receiver Type TRA.906, TRA.921 or TRA.922 is suitable.
- (b) A multimeter, 20 000 ohms per volt. The Avo Model 8 is suitable.
- (c) A.F. Signal Generator with a range of 20 to 3,000 Hz, and an output of 1mV to 1V at 600 $\Omega$  impedance. The Advance Type J2 is suitable.
- (d) 28 volt and 18 volt power supply. The Racal Power Unit and Loudspeaker Amplifier type MA.935 set to 18 volts is suitable.
- (e) Test Set (to provide power supply and a.f. signal generator input to the transmitter-receiver). The Racal Field Test Set Type CA.470B is suitable.
- (f) 100 watt, 50 ohm, r.f. power meter. The Marconi Type TF 1020A or TF 2503 is suitable.

#### Use of Test Set. CA.570B

3. The Test Set CA.470B simplifies connecting operations to the transmitter-receiver. The test set provides the following facilities.

- (a) A power supply with overload protection, allowing a transmitter-receiver to be driven from 100 to 125V or 200 to 250V, 45 to 60 Hz mains, without risk of damage due to internal short circuits, etc.

Para. 3 cont'd

- (b) A  $50\Omega$  dummy load incorporating a wattmeter, allowing easy measurements of output power. This dummy load must not be connected to the amplifier r.f. output.
  - (c) Connecting points for a.f. inputs, a.f. outputs and a frequency counter or oscilloscope.
  - (d) Transmit-Receive and Key switching.
4. The power supply circuit within the test set will 'trip out' if excess current is drawn, removing the power supply. To re-establish the power supply the POWER switch must be set to the OFF AND RESET position, then returned to the ON position.
5. If a test set is not available it will be necessary to use a six pole plug connected to an AUDIO socket on the transmitter-receiver, and to provide the power supplies, audio inputs and outputs, keying signals and p.t.t. signals.

PROCEDURES

Initial Procedure

- 6.
- (1) Check that the TA.940B amplifier, transmitter-receiver, CA.470B test set and MA.935 power unit and loudspeaker amplifier are all switched off.
  - (2) Connect a coaxial cable between the TA.940B R.F. OUTPUT socket and the 100watt r.f. power meter (see Fig. 1).
  - (3) Connect a second coaxial cable between the TA.940B R.F. INPUT and the  $50\Omega$  socket, covering the 4-8 MHz range, on the transmitter-receiver.
  - (4) Connect a lead that is terminated with a 6-way Thorn Pygmy plug at each end, between an AUDIO socket on the TA.940B and an AUDIO socket on the transmitter-receiver.
  - (5) Connect a lead, terminated with a 2-way socket and a 2-way plug, between the 2-way socket on the MA.935 and the 2-way plug on the TA.940B.
  - (6) Connect the flying lead, terminated with plug PL3 on the CA.470B test set, to the remaining AUDIO socket on the transmitter-receiver.
  - (7) Connect the test set flying lead terminated with plug PL2, to the remaining AUDIO socket on the TA.940B and connect all EARTH terminals to earth using stout wire or braid.
  - (8) Connect  $600\Omega$  output from the a.f. generator to the MOD and EARTH terminals on the test set.

Para. 6 cont'd

- (9) Set the a.f. generator frequency to 1 000 Hz at a minimum output level.
- (10) Set the transmitter-receiver to the highest usable frequency.
- (11) Set the POWER switches on the test set and power unit to ON.
- (12) On the transmitter-receiver select the TUNE position and, if either the TRA.921 or TRA.922 is used, set the HIGH-LOW POWER switch to LOW POWER.

CAUTION: It is important that LOW POWER is selected.

- (13) Set the test set TRANS-REC switch to TRANS and adjust the transmitter-receiver TUNE control for a maximum reading on the meter.
- (14) Set the transmitter-receiver to VOICE L.S.B. (or to S.S.B. for the TRA.906).

Setting to Suit Input Level

7. The TA.940B can be set to suit inputs of 1-5W or 100mW (nominal). The units are normally set for 5W (nominal) input, and should be adjusted only if the input level setting is incorrect, or a 100mW input is required. The procedure is as follows:-

Setting for 1 or 5W input.

8. (1) With the equipment connected as in the previous paragraph remove the r.f. input to the TA.940B and connect it to the Power Meter, in place of the output from the TA.940B.
- (2) Connect link LK2 between pins B17 and B18 (see Figs. 5 and 7) and remove the link LK1 from pins B19 and B20.
- (3) Adjust the audio generator output level to give a power output of 0.5W with the transmit condition selected. Release the pressel switch.
- (4) Re-connect the transmitter-receiver output to the TA.940B input and the TA.940B output to the power meter.
- (5) Switch on, depress pressel switch and adjust R24 as follows:-
  - (a) If the transmitter-receiver normally delivers 5W (e.g. TRA.921 or TRA.922 in LOW power, TRA.906), adjust R24 to give an output of 20W.
  - (b) If the transmitter-receiver normally delivers 1W (e.g. TRA.929) adjust R24 to give an output of 50W.

Para. 8 cont'd

- (6) Adjust the level of the audio generator to give an output of 100W, ready for the following procedure, release pressel and switch off.

Setting for 100mW input

9. Switch off the equipment and connect link LK1 between pins B19 and B20 (see Figs. 5 and 7). Remove link LK2 from pins B17 and B18. The unit is now correctly set for 100mW input.

NOTE: This setting is for use with a low power exciter or a signal generator as the r.f. source.

Setting the Collector Current Detector

10. (1) Remove the coaxial cable from the 4-8 MHz socket of the transmitter-receiver and connect it to the 2-4 MHz socket. Set the transmitter-receiver to 2MHz or the nearest available frequency.
- (2) Set the a.f. generator frequency to 1000Hz at a minimum output level.
- (3) Select the TUNE position at the transmitter-receiver and adjust the TUNE Control to give maximum output as indicated on the meter of the unit.
- (4) Select VOICE LSB (or SSB for TRA906).
- (5) Switch on TA.940B and adjust the audio generator level to give an output power meter reading of 50W. Switch off the TA.940B.
- (6) Set R99 (in the TA.940B) fully anti-clockwise.
- (7) Switch off the MA.935 and connect a multimeter, set to the 0-10A d.c. range, in one side of the 28V supply to the TA.940B (from the MA.935).

NOTE: The multimeter can be connected across switch SA with the switch set to OFF. The external supply should be switched off whilst making connections.

- (8) Disconnect the power meter from the RF OUTPUT socket of the TA.940B and place a short circuit across the socket.
- (9) Switch on the MA.935 and depress the pressel.
- (10) Adjust R99 until a reading of 9.5A is indicated in the multimeter.
- (11) Release the pressel and switch off the equipment. Remove the test gear and short circuit and re-make disturbed connections.



## CHAPTER 7

### FAULT LOCATION

#### INTRODUCTION

1. This chapter assumes that all the ancillary equipment, e.g. transmitter-receiver power supply, etc. are operating satisfactorily. For fault location of the ancillary equipment, the relevant handbooks should be consulted.
2. An initial procedure is given that does not necessitate opening up the amplifier and is followed by an internal fault location procedure.

#### TEST EQUIPMENT

3. The following test equipment is required in addition to that listed in Chapter 6.
  - (a) Valve Voltmeter, having d.c. and r.f. ranges up to 30 MHz. The Marconi Type TF 2604 is suitable.
  - OR
  - (b) Oscilloscope having a frequency range from d.c. to 30 MHz and a sensitivity of 50 mV/cm. The Advance Type OS 2100 is suitable.

#### INITIAL FAULT LOCATION

4. The D.C. ON and R.F. OUTPUT indicator lamps light when amplifier operation is correct.
5. The D.C. ON lamp should light when the D.C. switch is set to ON, unless there is either a 28 volt supply failure or fuse FS1 has blown (to replace this fuse, the rear cover must be removed as described in Chapter 5).
6. The R.F. OUTPUT lamp illuminates when transmission takes place. This lamp will not illuminate if there is no r.f. input from the transmitter-receiver, an internal fault in the amplifier, an open circuit in the output stage, or if there is an excessive rise in temperature causing the thermal cut-out to open. The existence of an r.f. input can be confirmed by setting the transmitter-receiver to TUNE and checking for an indication on the transmitter-receiver meter. The non-existence of an r.f. output can be confirmed by checking for an indication on the antenna tuning unit meter. An excessive rise in the operating temperature of the amplifier could be caused by driving the amplifier for a long period from a transmitter-receiver set to HIGH POWER: lengthy operation in high ambient temperatures, or by restriction of the air flow over the cooling fins. If it is suspected that the thermal cut-out has opened, the amplifier should be allowed to cool down for approximately 10 minutes before attempting to operate it again, and LOW POWER selected.

## GENERAL FAULT LOCATION

7. Reference should be made to the circuit diagram Fig. 7 and component layouts Figs. 3 to 6. Typical signal and voltage levels are given at the end of this Chapter.
8. The procedures given below should be carried out in the order given, as a test may be valid only if those preceding it have been performed. Dismantling instructions are given in Chapter 5.
9.
  - (1) Connect the amplifier as described in Chapter 6, paragraph 6, Operations (1) to (9), and tune the equipment to 2 MHz.
  - (2) Check that the TRANS-REC switch of the CA.470B is in the REC position.
  - (3) Set the D.C. switch on the amplifier, and the POWER switches on the test set and the power unit to ON. Select TUNE on the transmitter-receiver.

### Supply Checks

10.
  - (1) Using the multimeter, check for d.c. volts (between +24V and +28V) at pin B7 on the low level board and pins A6 and A4 and A1 on the high power board. Check for a fault between D.C. switch SA and a pin without d.c. volts. If d.c. volts are satisfactory, proceed to the next test.
  - (2) Select TRANS on the test set TRANS-REC switch and check for d.c volts (+24V to 28V) at pin B11 on the low level board and pins A5 and A7 on the high power board. If a d.c. voltage is not shown, check for a faulty relay or thermal cut-out X1. If d.c. voltage is satisfactory, proceed to the next test.
  - (3) Check for +22 volts at the junction of R9 and R19. If a d.c. voltage is not present the fault may be due to resistor R9 or to a faulty connection. If d.c. voltage is satisfactory proceed to R.F. checks.

### R.F. Checks

NOTE: Reference should be made to tables 1 and 2 at the end of this Chapter for signal and d.c. levels respectively.

11.
  - (1) Using an oscilloscope or valve voltmeter, check for a signal level at pin B12. If no signal is present proceed to the next test. If a satisfactory signal is present, check for a fault between pin B12 and the R.F. OUTPUT socket SKD.

Para. 11 cont'd

- (2) Check the signal level at pin B13. If a signal is not present, proceed to the next test. If the signal is satisfactory, relay contact RLB-2 may be faulty.
- (3) Check the signal level at pin B3. If a signal is not present, proceed to the next test. If the signal is satisfactory, fault may be on high level board.
- (4) Check the signal level at pin B20. If no signal is present proceed to the next test. If a satisfactory signal is present the fault will probably be in the pre-driver low level stages.
- (5) Check the signal level at pin B17. If a signal is not present proceed to the next test. If a satisfactory signal is present fault may be in the attenuator.
- (6) Check the signal level at pin B9. If a signal is not present check for a fault in the connection to the R.F. INPUT socket SKC. If the signal is satisfactory, fault is at relay contact RLA-2.

High Power Board (Figure 6)

12. (1) Check the collector r.f. voltages at transistors TR5, TR6, TR11, TR16, TR20 to TR23. No signal or incorrect level, proceed to the next test. If satisfactory voltages are present, either transformer T9 or T22 may be open circuit.
- (2) Check the emitter r.f. voltages at transistors TR5, TR6, TR11, TR16, TR20 to TR23. No signal or incorrect level, proceed to the next test. If voltages are satisfactory either transformer T9 or T22 is short circuited, or inductor L1 is short circuited.
- (3) Check the collector r.f. voltages at transistors TR18 and TR19. No signal or incorrect level, proceed to the next test. If voltages are satisfactory a fault at transistors TR5, TR6, TR11, TR16 or TR20 to TR23 is indicated.
- (4) Check the emitter r.f. voltages, at transistors TR18 and TR19. If no signal or an incorrect level is present a fault associated with resistors R49 to R52, R57, R59, R60 or R62, or an open circuit at transformers T13, T14, T17 or T18 is indicated. If voltages are satisfactory a fault at either TR18 or TR19 is indicated.

NOTE: A check, using the multimeter, of the d.c. voltages at the transistors on this board may locate a faulty component.

Low Level Board (Figure 5)

13. (1) Check the collector r.f. voltages at transistors TR1 to TR4. No signal or incorrect level, proceed to the next test. If voltages are satisfactory check for an open circuit at transformer T1.
- (2) Check the collector r.f. voltage at transistors TR8 and TR9. No signal or incorrect level, proceed to the next test. If voltage is satisfactory a fault associated with TR1 to TR4, or transformers T3 to T7 is indicated.
- (3) Using the multimeter, check the voltage between the bases of TR7, TR10 and TR8, TR9. If the bases of TR7, TR10 are more positive than the bases of TR8, TR9 proceed to the next test. If the bases of TR8, TR9 are more positive than the bases of TR7, TR10 transistors TR8 or TR9 may be faulty.
- (4) Check the voltage between the base of TR12 and the base of TR15. If TR12 base is more positive than TR15 base the fault may be in transistor TR17 or associated circuit. If the polarity is reversed the fault may be in TR12 to TR15 or the Collector Current Detector, TR24 to TR26.
- (5) Remove the r.f. input from the amplifier and check, using the multimeter, the d.c. voltage at transistors TR12, TR13, TR14, TR15 and TR17 (refer to the following table.).

(Continued on next page)

TABLE 1

TYPICAL R.F. SIGNAL LEVELS

R.F. signal levels were taken with an r.f. input of 5W and an output of 100W into a 50 ohm load, and were measured with an oscilloscope using an h.f.  $\div 10$  probe.

Test Position	2 MHz	30 MHz
SKD, Pin 12, Pin 13.	225V peak-to-peak	180V peak-to-peak
Collectors TR5, TR6, TR11, TR16, TR20 to TR23	46V peak-to-peak	42V peak-to-peak
Emitters of TR5, TR6, TR11, TR16, TR20 to TR33.	1.6V peak-to-peak	—
Collectors of TR18, TR19.	15V peak-to-peak	37.5V peak-to-peak
Emitters of TR18, TR19.	2V peak-to-peak	—
Pin B3	16V peak-to-peak	32V peak-to-peak
Collectors of TR1 to TR4	16V peak-to-peak	35V peak-to-peak
Collectors of TR8, TR9.	5.5V peak-to-peak	8.4V peak-to-peak
Pins B9, B17 and B18	45V peak-to-peak (5W nom.)	41V peak-to-peak

TABLE 2

TYPICAL D.C. VOLTAGE LEVELS

The following voltages were measured using an Avo 8 multimeter, with no r.f. drive to the TA.940B, and with a 28V supply.

	<u>EMITTER</u>	<u>BASE</u>	<u>COLLECTOR</u>
TR1	0.75V	1.3V	28V
TR2	0.75V	1.3V	28V
TR3	0.75V	1.3V	28V
TR4	0.75V	1.3V	28V
TR5	0V	0.55V	28V
TR6	0V	0.55V	28V
TR7	9.0V	9.2V	22V
TR8	9.0V	9.7V	22V
TR9	9.0V	9.7V	22V
TR10	9.0V	9.2V	22V
TR11	0V	0.55V	28V
TR12	9.8V	10.2V	28V
TR13	9.2V	9.8V	28V
TR14	9.7V	10.3V	28V
TR15	10.3V	10.7V	28V
TR16	0V	0.55V	28V
TR17	6.65V	7.3V	6.75V
TR18	0V	0.55V	28V
TR19	0V	0.55V	28V
TR20	0V	0.55V	28V
TR21	0V	0.55V	28V
TR22	0V	0.55V	28V
TR23	0V	0.55V	28V
TR24	27.5	27.2V	0V
TR25	27.5	27V	23V
TR26	27.5	27.2V	0V

## ORDERS FOR SPARE PARTS

In order to expedite handling of spare part orders, please quote:-

- (1) Type and serial number of equipment .
- (2) Circuit reference, description, Racal part number, and manufacturer of part required .
- (3) Quantity required .

**NOTE:** If the equipment is designed on a modular basis, please include the type and description of the module for which the replacement part is required.





## ALTERNATIVES

Certain recommended alternative components are listed below. These alternative components may be used when the appropriate item given in the following components list is no longer available.

Cct. Ref.	Value	Description	Rat.	Tol. %	Racal Part Number	Manufacturer
TR5					922426	RCA 16145
TR6					922426	RCA 16145
TR11					922426	RCA 16145
TR16					922426	RCA 16145
TR18					920568	Mullard 2N5070
TR19					920568	Mullard 2N5070
TR20					922426	RCA 16145
TR21					922426	RCA 16145
TR22					922426	RCA 16145
TR23					922426	RCA 16145

## =====

### COMPONENTS LIST

## =====

Cct. Ref.	Value Ω	Description	Rat. W	Tol. %	Racal Part No.
<b>Resistors</b>					
R1	330	Wirewound	9	5	913758
R2	330	Wirewound	9	5	913758
R3	1	Wirewound	2½	10	911767
R4	10	Wirewound	2½	5	913571
R5	47	Wirewound	6	5	913694
R6	1	Metal Oxide	½	5	917781
R7	1	Metal Oxide	½	5	917781
R8	10	Metal Oxide		5	908471
R9	470	Wirewound	6	5	913670
R10	10	Metal Oxide		5	908471
R11	10	Metal Oxide		5	908471
R12	10	Metal Oxide		5	908471
R13	10	Metal Oxide		5	908471
R14	100	Metal Oxide		5	907491
R15	100	Metal Oxide		5	907491
R16	100	Metal Oxide		5	907491
R17	1	Metal Oxide	½	5	917781
R18	1	Metal Oxide	½	5	917781
R19	47	Metal Oxide		5	907495
R20	47	Metal Oxide		5	907495
R21	470	Metal Oxide		5	906019
R22	100	Metal Oxide		5	913962
R23	100	Metal Oxide		5	913962
R24	470	Variable, linear			907497
R25	100	Carbon		20	917786
R26	100	Carbon		20	917786
R27	100	Metal Oxide		5	913962
R28	1	Metal Oxide	½	5	917781
R29	1	Metal Oxide	½	5	917781
R30	100k	Metal Oxide		5	907866
R31	1k	Metal Oxide		5	906031
R32	1k	Metal Oxide		5	906031
R33	100k	Metal Oxide		5	907866
R34	1k	Metal Oxide		5	906031
R35	100	Metal Oxide		5	907491

Cct. Ref.	Value Ω	Description	Rat. W	Tol. %	Racal Part No.
<u>Resistors (continued)</u>					
R36	100	Metal Oxide		5	907491
R37	1	Metal Oxide	$\frac{1}{2}$	5	917781
R38	1	Metal Oxide	$\frac{1}{2}$	5	917781
R39	Not Used				
R40	470	Metal Oxide		5	906019
R41	470	Wirewound	9	5	913672
R42	47	Metal Oxide		5	907495
R43	47	Metal Oxide		5	907495
R44	1.8k	Metal Oxide		5	906026
R45	4.7	Wirewound	$2\frac{1}{2}$	5	917145
R46	47	Wirewound	$2\frac{1}{2}$	5	913588
R47	2.2k	Metal Oxide		5	906020
R48	10k	Metal Oxide		2	906023
R49	12	Metal Oxide		5	915455
R50	12	Metal Oxide		5	915455
R51	12	Metal Oxide		5	915455
R52	12	Metal Oxide		5	915455
R53	2.2k	Metal Oxide		5	906020
R54	100k	Metal Oxide		5	907866
R55	120	Metal Oxide		2	918048
R56	100k	Metal Oxide		5	907866
R57	12	Metal Oxide		5	915455
R58	220	Metal Oxide		2	909549
R59	12	Metal Oxide		5	915455
R60	12	Metal Oxide		5	915455
R61	120	Metal Oxide		2	918048
R62	12	Metal Oxide		5	915455
R63	4.7	Wirewound	$2\frac{1}{2}$	5	917145
R64	47	Wirewound	$2\frac{1}{2}$	5	913588
R65	10k	Metal Oxide		2	906023
R66	470	Wirewound	9	5	913762
R67	470	Metal Oxide		5	906019
R68	1	Metal Oxide	$\frac{1}{2}$	5	917781
R69	1	Metal Oxide	$\frac{1}{2}$	5	917781
R70	10k	Metal Oxide		2	906023

Cct. Ref.	Value Ω	Description	Rat. W	Tol. %	Racal Part No.
<b>Resistors (continued)</b>					
R71	100	Metal Oxide		5	907491
R72	100	Metal Oxide		5	907491
R73	1	Metal Oxide	$\frac{1}{2}$	5	917781
R74	1	Metal Oxide	$\frac{1}{2}$	5	917781
R75	470	Metal Oxide		5	906019
R76	470	Metal Oxide		5	906019
R77	220	Metal Oxide		2	909774
R78	1k	Metal Oxide		5	906031
R79	1	Metal Oxide	$\frac{1}{2}$	5	917781
R80	1	Metal Oxide	$\frac{1}{2}$	5	917781
R81	100	Metal Oxide		5	907491
R82	100	Metal Oxide		5	907491
R83	1	Metal Oxide	$\frac{1}{2}$	5	917781
R84	1	Metal Oxide	$\frac{1}{2}$	5	917781
R85	330	Wirewound	9	5	913758
R86	1	Wirewound	$2\frac{1}{2}$	10	911767
R87	10	Wirewound	$2\frac{1}{2}$	5	913571
R88	330	Wirewound	9	5	913758
R89	1k	Metal Oxide		5	906031
R90	470	Metal Oxide		5	906019
R91	2.2k	Metal Oxide		5	906020
R92	2.2k	Metal Oxide		5	906020
R93	0.1	Wirewound	$2\frac{1}{2}$	10	921359
R94	0.1	Wirewound	$2\frac{1}{2}$	10	921359
R95	220	Metal Oxide		2	909549
R96					
R97	0.1	Wirewound	$2\frac{1}{2}$	10	921359
R98	470	Metal Oxide		5	906019
R99	250	Variable			912517
R100	2.2k	Metal Oxide		5	906020
R101	0.1	Wirewound	$2\frac{1}{2}$	10	921359
R102	10k	Metal Oxide		5	906023
R103	470	Metal Oxide		5	906019
R104	2.2k	Metal Oxide		5	906020

Cct. Ref.	Value $\Omega$	Description	Rat. W	Tol. %	Racal Part No.
Capacitors $\mu$ F					
C1	0.1	Fixed		20	917136
C2	.01	Fixed		20	917771
C3	.01	Fixed		20	917771
C4	.01	Fixed		20	917771
C5	0.1	Fixed		20	917136
C6	0.1	Fixed		20	917136
C7	10	Electrolytic	20	20	905399
C8	0.1	Fixed		20	917136
C9	0.1	Fixed		20	917136
C10	0.1	Fixed		20	917136
C11	0.1	Fixed		20	917136
C12	0.1	Fixed		20	917136
C13	0.1	Fixed		20	917136
C14	0.1	Fixed		20	917136
C15	0.1	Fixed		20	917136
C16	0.1	Fixed		20	917136
C17	0.1	Fixed		20	917136
C18	0.1	Fixed		20	917136
C19	0.1	Fixed		20	917136
C20	0.1	Fixed		20	917136
C21	0.1	Fixed		20	917136
C22	100	Electrolytic	20	20	913970
C23	0.1	Fixed		20	917136
C24	0.1	Fixed		20	917136
C25	100	Electrolytic	20	20	913970
C26	0.1	Fixed		20	917136
C27	0.1	Fixed		20	917136
C28	0.1	Fixed		20	917136
C29	0.1	Fixed		20	917136
C30	0.1	Fixed		20	917136
C31	.001	Ceramic	+100-0		917769
C32	0.1	Fixed		20	917136
C33	0.1	Fixed		20	917136
C34	0.1	Fixed		20	917136
C35	.001	Ceramic	+100-0		917769

Cct. Ref.	Value μF	Description	Rat. V	Tol. %	Racal Part No.
C36	0.1	Fixed		20	917136
C37	0.1	Fixed		20	917136
C38	.001	Ceramic	+100-0		917769
C39	.001	Ceramic	+100-0		917769
C40	0.1	Fixed		20	917136
C41	0.1	Fixed		20	917136
C42		Not Used			
C43		Not Used			
C44	0.1	Fixed		20	917136
C45	0.1	Fixed		20	917136
C46	0.1	Fixed		20	917136
C47	0.1	Fixed		20	917136
C48	47	Electrolytic	35	20	917478
C49	0.1	Fixed		20	917136
C50	0.1	Fixed		20	917136
C51	0.1	Fixed		20	917136
C52	0.1	Fixed		20	917136
C53	0.1	Fixed		20	917136
C54	47	Electrolytic	35	20	917478
C55	0.1	Fixed		20	917136
C56	47	Electrolytic	35	20	917478
C57	0.1	Fixed		20	917136
C58	47	Electrolytic	35	20	917478
C59	0.1	Fixed		20	917136
C60	47	Electrolytic	35	20	917478
C61	0.1	Fixed		20	917136
C62	0.1	Fixed		20	917136
C63	0.1	Fixed		20	917136
C64	15p	Fixed	500V	5	917747
C65	0.47	Fixed	63V	20	916167
C66	0.1	Fixed	100V	20	917936
C67	0.47	Fixed	63V	20	916167
C68	0.47	Fixed	63V	20	916167

Cct. Ref.	Value $\mu$ F	Description	Rat. V	Tol. %	Racal Part No.
<u>Inductors</u>					
L1					900760
L2		Core, ferrite			917797
<u>Transformers</u>					
T1					710059
T2					710050
T3					710051
T4					710051
T5					710050
T6					710051
T7					710051
T8					710050
T9		Output			710040
T10					710058
T11					710050
T12					710050
T13					710061
T14					710061
T15		Interstage			710042
T16	Not Used				
T17					710061
T18					710061
T19	Not Used				
T20					710050
T21					710050
T22		Output			710040
T23					710062
T24					710050
T25					710050
<u>Diodes</u>					
D1					917775
D2					917775
D3					914898
D4					917773
D5					917773

Cct. Ref.	Value	Description	Rat.	Tol. %	Racal Part No.
<u>Diodes (continued)</u>					
D6					914898
D7					914898
D8					18/916632
D9					18/916632
D10					914898
D11					914898
D12	Zener				914064
D13					914898
D14					914898
D15					914898
D16					914898
D17					18/916632
D18					18/916632
D19					91498
D20	Transient Suppressor				922791
D21					914898
D22					914898
D23					914898
D24					917775
D25					917775
D26					917217
D27					914898
D28					914898
D29					914898
D30	Zener				916064
<u>Transistors</u>					
TR1					923252
TR2					923252
TR3					923252
TR4					923252
TR5					923252
TR6					917776
TR7					917219
TR8					917219
TR9					917219
TR10					917219



Cct. Ref.	Value	Description	Rat.	Tol. %	Racal Part No.
<u>Transistors (continued)</u>					
TR11					917776
TR12					906004
TR13					906004
TR14					906004
TR15					906004
TR16					917776
TR17					18/916632
TR18					917776
TR19					917776
TR20					917776
TR21					917776
TR22					917776
TR23					917776
TR24					919125
TR25					919125
TR26					919125
<u>Plugs</u>					
PLA		Two pin			9177898
<u>Sockets</u>					
SKA		6 pin			53/909908
SKB		6 pin			53/909908
SKC		Coaxial			905449
SKD		Coaxial			905449
<u>Relays</u>					
RLA		2 pole 24V 675Ω			917779
RLB		2 pole 24V 675Ω			917779
RLC		2 pole 24V 675Ω			917779
<u>Switches</u>					
SA		Toggle S.P.D.T.			917792

Cct. Ref.	Value	Description	Rat.	Tol. %	Racal Part No.
--------------	-------	-------------	------	-----------	-------------------

Miscellaneous

FX1		Ferrite bead			900461
FX2		Ferrite bead			900461
X1		Thermal switch			711089
LP1	}	Lamp, holder, LH23			918947
LP2					
LP1		Lens cap, frosted glass (clear)			902892
LP2		Lens cap, frosted glass (green)			918948
		Lamp, filament (two) 28V 0.04A			900908
FS1		Fuselink, 25A, size 0			911143
		Fuseholder, size 0			917793
		Desiccator			909909

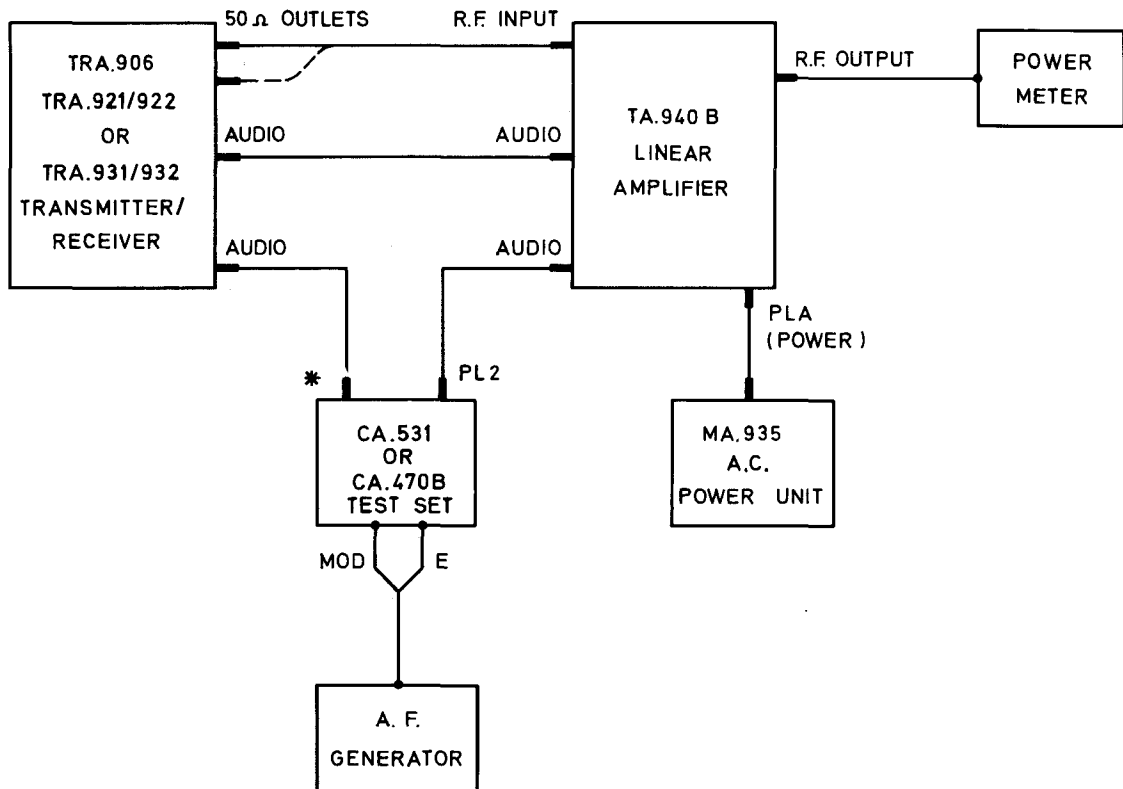

NOTE:

1. THE CA.470B TEST SET (18V SUPPLY) MAY ONLY BE USED WITH TRA.906 OR TRA.921/922 TRANSMITTER/RECEIVERS
2. \* PL1 ON CA.531 TEST SET  
PL3 ON CA.470B TEST SET

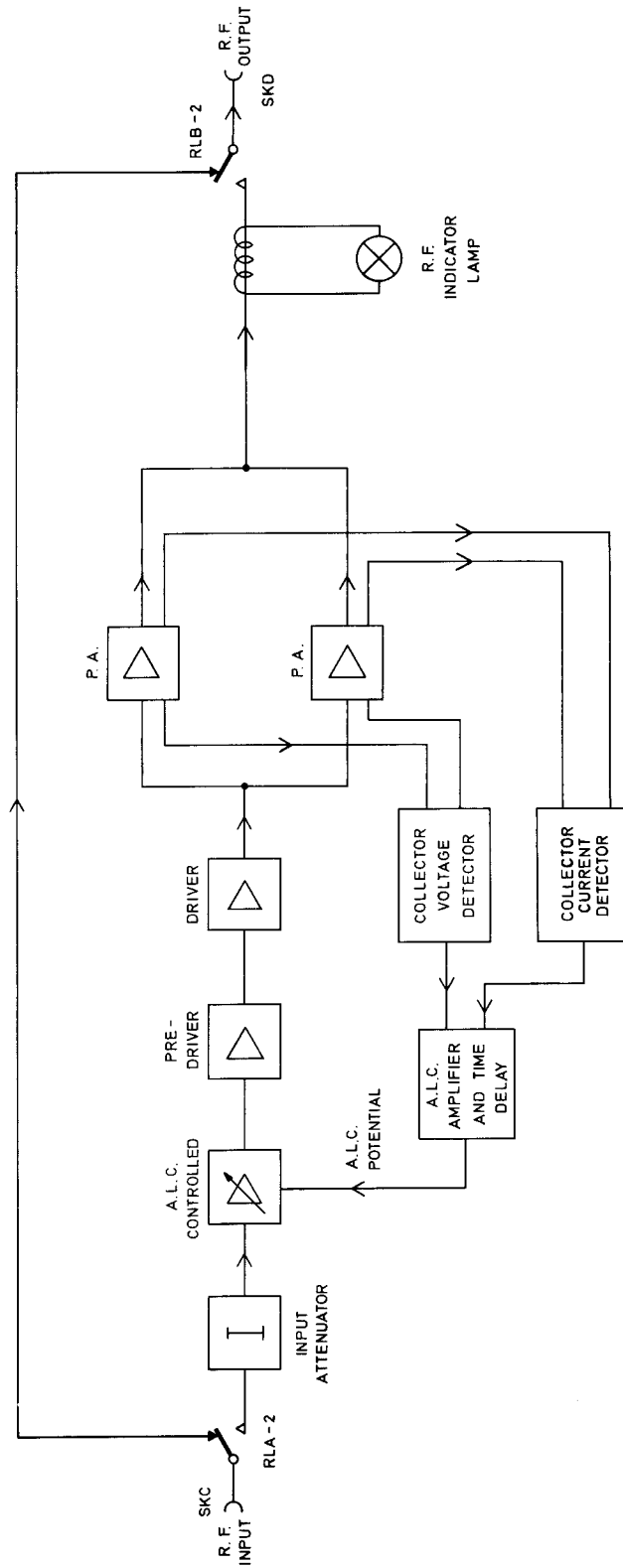

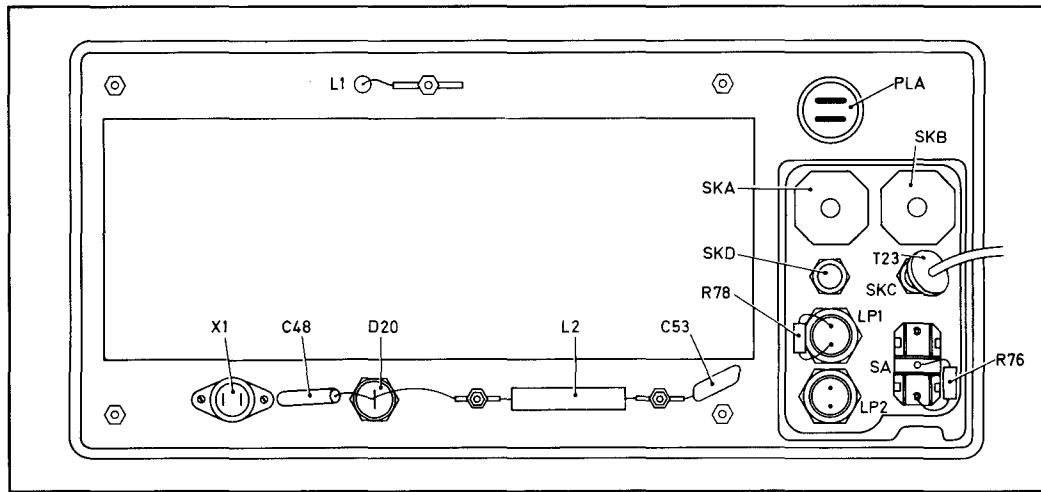

PLAN VIEW

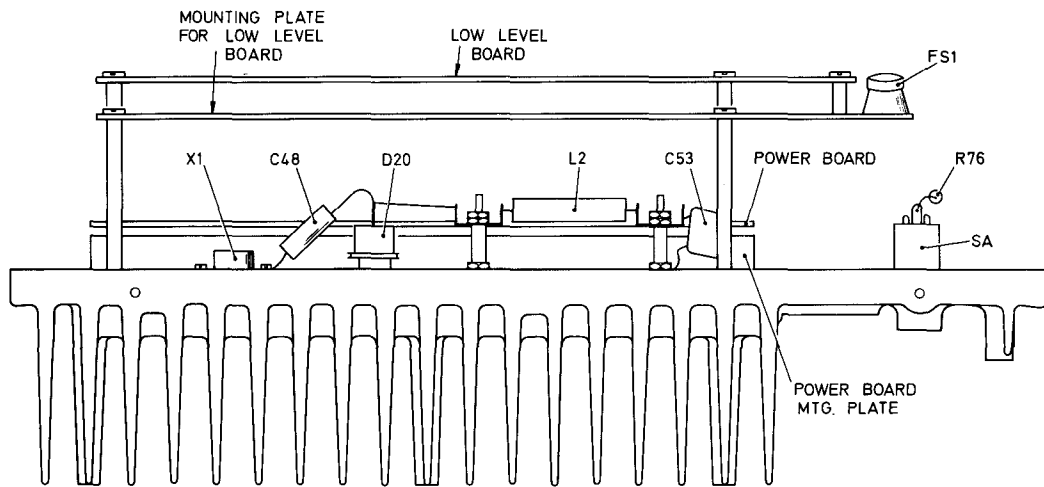

SIDE VIEW

Plan and Side Views  
with Cover Removed. TA.940B

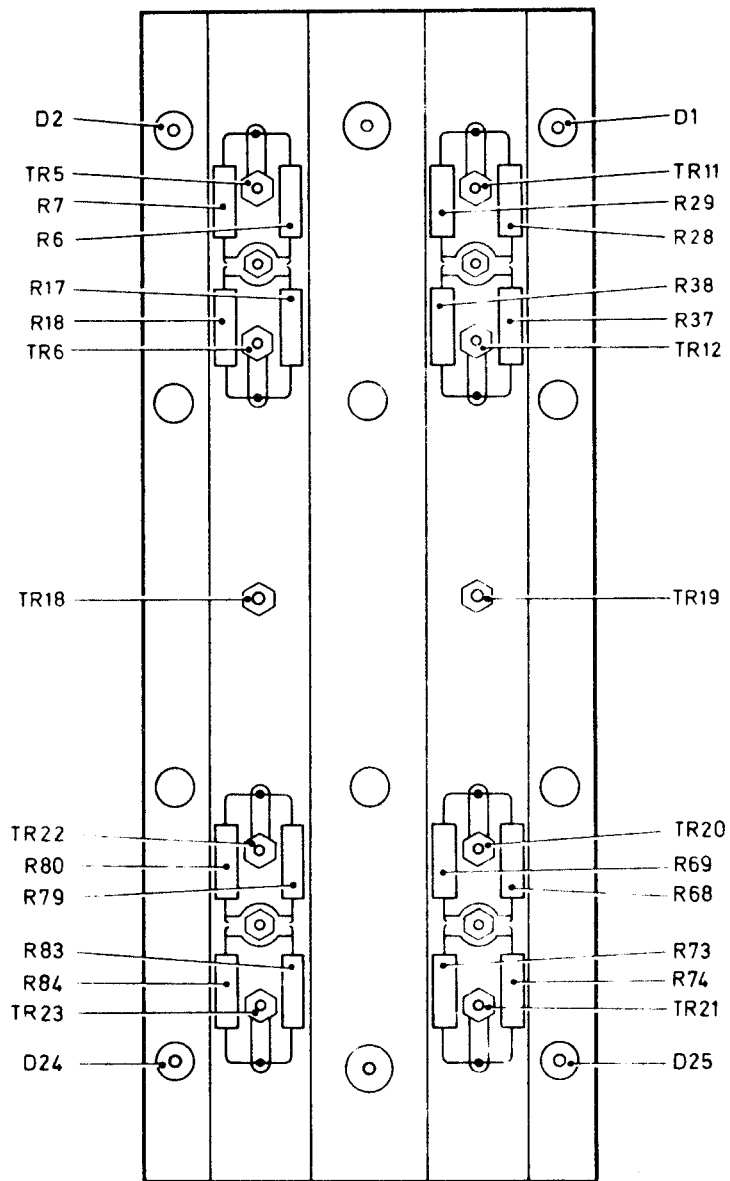

Underside of Power Board  
Mounting Plate : TA.940B

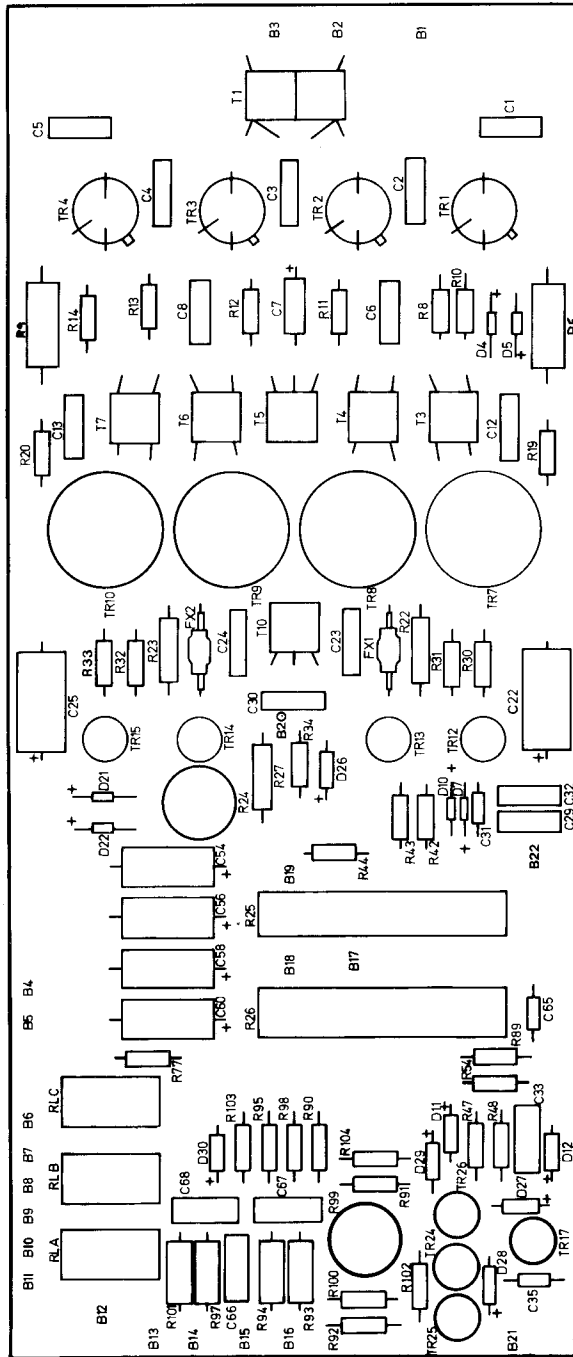

Component Layout:  
Low Level Board TA.940B

Fig. 5





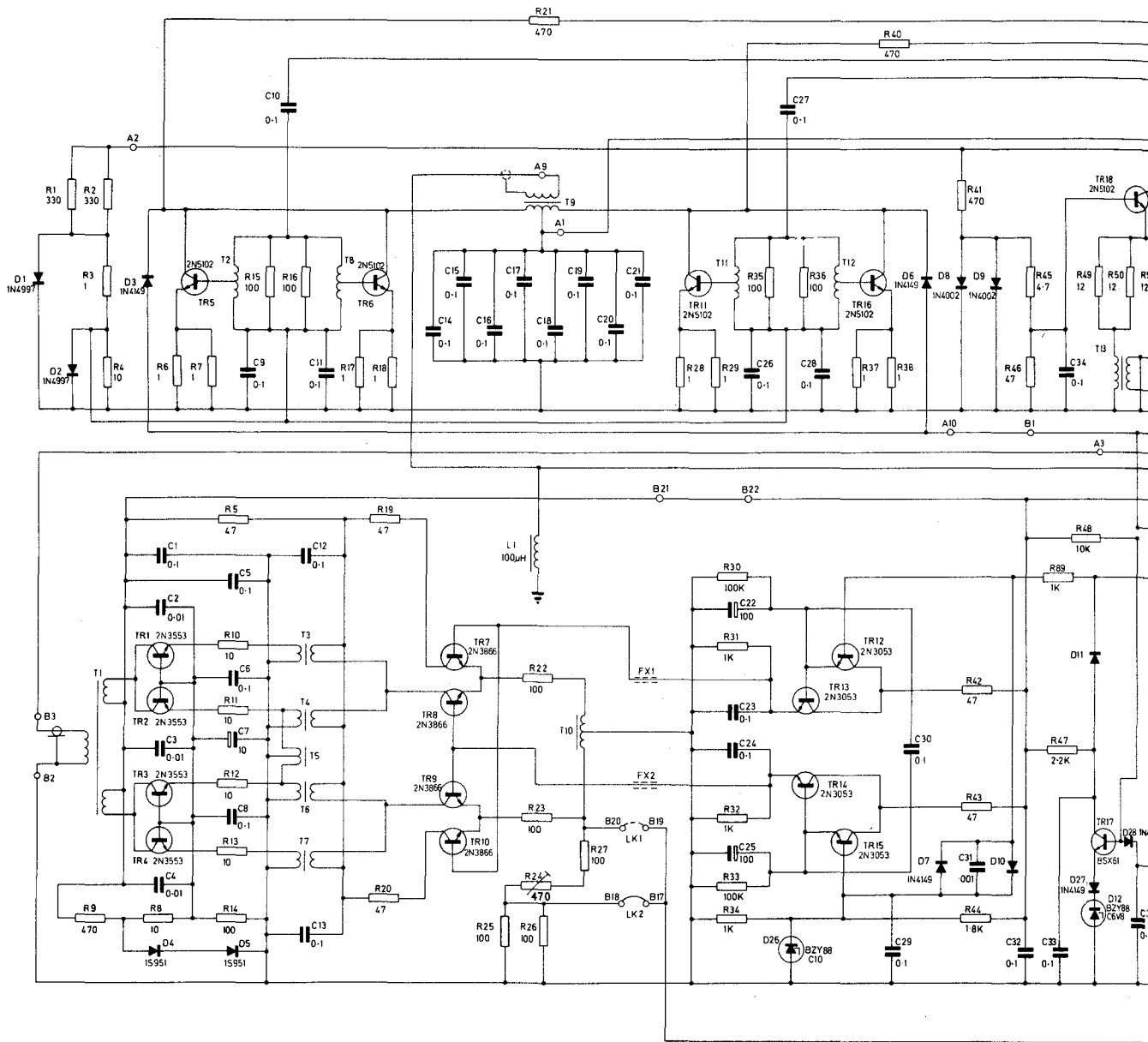

WQH1122 EC700670  
315

Circuit: 100W



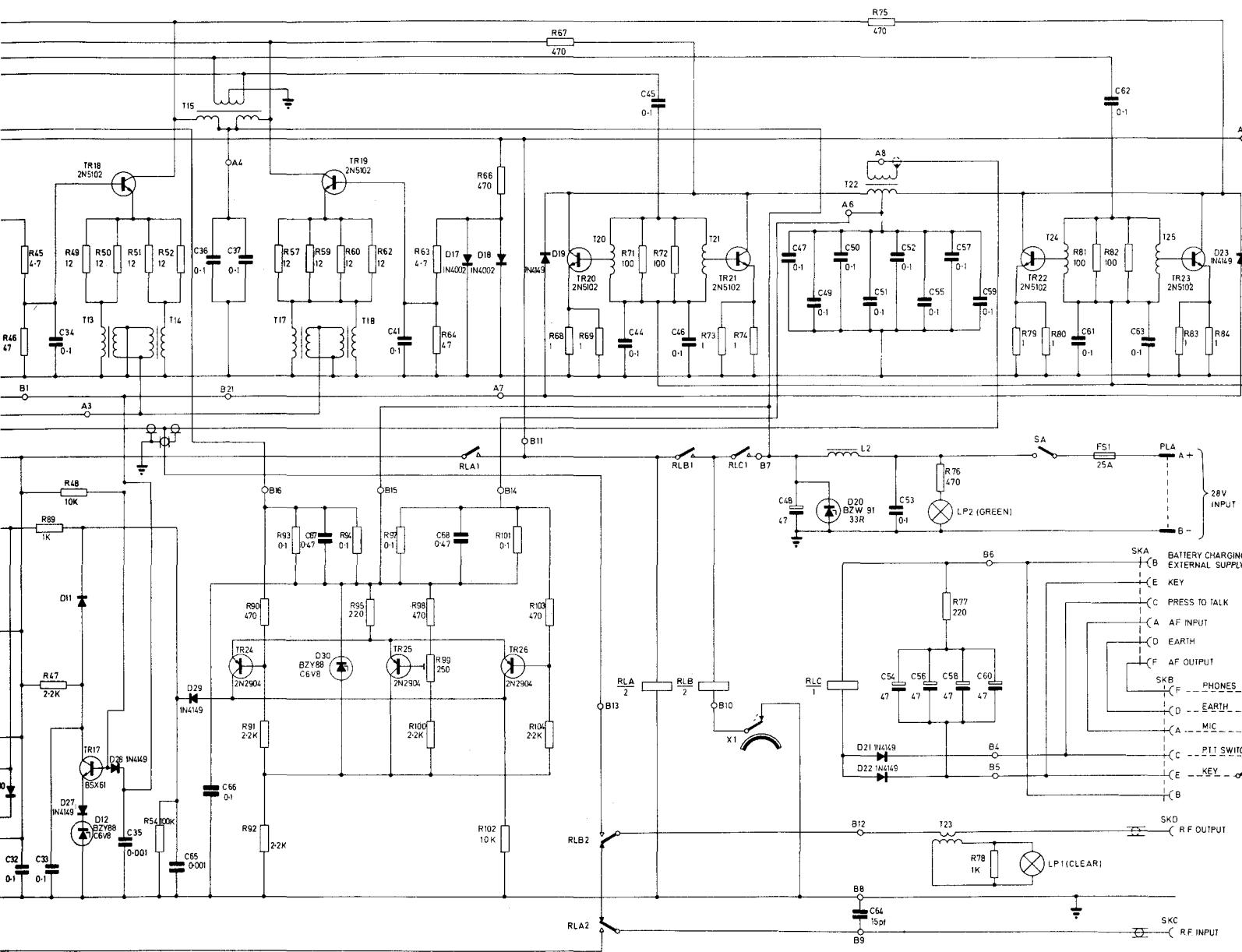



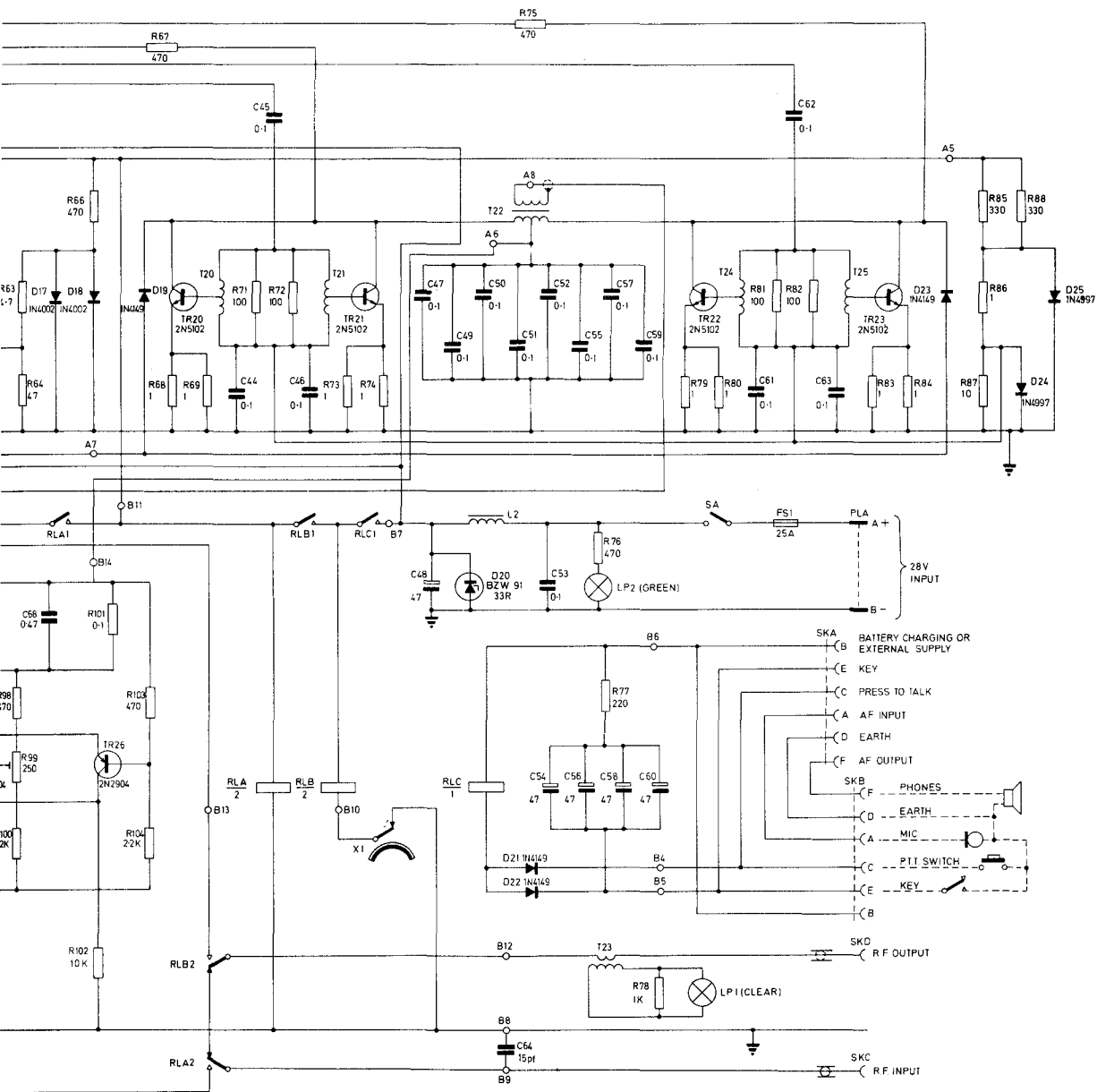

Fig. 7