

WIRELESS SET CANADIAN NO. 19 MK 3

Field and Base Repair

Supersedes all previous issues

GENERAL

Test Equipment

1. The following test equipment, or equivalent, will be required for alignment and specification tests

- (a) 4Z 1004335 GENERATOR, signal AF/RF Waveforms Model 510B c/w matching transformer Model T10.
- (b) 4Z 1011695 GENERATOR, signal, RF AN/URM 25(D).
- (c) 4Z WY/CAN 13391 GENERATOR, signal, RF 110/125V 25-60 cps Advance Comp type D1
- (d) 4Z-2C-1411.5 FREQUENCY METER, set, SCR 211.
- (e) 4Z 1014495 OSCILLOSCOPE, CR 3-in OS-8(B)/U.
- (f) 4Z 1013150 TEST SET, radio, Stark Model VT-9A.
- (g) 4Z 1014802 WATTMETER, RF, ME 5005/U.
- (h) 4Z 1014829 WATTMETER, AF, ME 5006/U.
- (j) 4Z 1002177 TRANSFORMER, variable power, variac V-5HMT.
- (k) 1Z 001273 POWER SUPPLY, metallic, CPP2

2 In addition the following items are required for the operation of the equipment

<u>COC NO.</u>	<u>Designation</u>	<u>Qty</u>
ZA/CAN/BR-10358	CONTROL UNITS No. 2 MK 2 Cdn	1
ZA/CAN/BR-17603	MICROPHONE AND RECEIVER HEADGEAR assembly Cdn Type 10 (Held in stock as ZA/CAN 1570)	1
ZA/CAN/BR-10242	CONNECTORS TWIN # 88 Cdn	1
6625-101-8657	WIRING HARNESS, 12 conductor	2
ZA/CAN-4476	CAPACITORS, oil paper 2 uf 600V No. C1	1

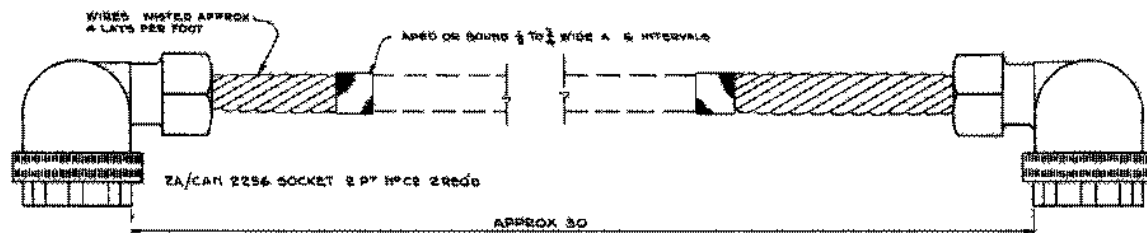

WIRING			
FROM	TO	WIRE	
SOCKET'S PIN	SOCKET'S P.N.	3Y100485 WIRE ELECTS CA STRANDED 8 GAUGE BLACK	
2	2	3Y100 28	22
3	3	3Y 021628	18 RED
4	4	3Y100 54	22
5	5		
6	6		
7	7		
8	8		
9	9		
10	10		
11	11		
12	12		

DEME 88271

Fig 1 - Wiring harness 12-conductor

3. The alignment of the Wireless Set No 19 Mk 3 has been revised completely, due to introduction of new standard test equipment with resultant changes in specification figures

'A' SET RECEIVER ALIGNMENT

4. Since certain stages are common to both receiver and sender the drive circuits cannot be aligned until after final adjustments have been made to the local oscillator and bfo

5. Preliminary Adjustments

Unless otherwise specified -

- (a) Tune receiver to 8 mc
- (b) Set FLICK ADJ to its centre position
- (c) AF and RF gain controls to maximum.
- (d) AVC switch off.
- (e) System switch to R/T
- (f) NET switch to off.

Data

6. The following standards will be used for specification testing
- (a) Signal generator modulated 30 per cent at 400 cps.
 - (b) Output level for 'A' and 'B' sets 50 mw, into 100 ohms output impedance (no phones in circuit).
 - (c) Intermediate frequency 465 kc, ± 2 kc.
 - (d) LT voltage at pin 10 of PL 2A to be $12v \pm .25v$.
 - (e) A dummy 807 tube (pin 2 removed) is substituted for V 4A (pa stage) on all tests and adjustments EXCEPT for 'A' set sender output measurements.
 - (f) AF signal generator set for 600 ohms output impedance.

Audio Sensitivity

7. (a) Prepare set for specification testing as in para 4, 5, and 6
- (b) Connect AF wattmeter to output of set.
 - (c) Feed a 400 cps signal into control box microphone circuit (pins 4 and 5 of drop cord) through a 20 db matching pad.
 - (d) The output, indicated on the wattmeter by switching control box selector switch (S13A) through 'A' - 'IC' and 'B', with 'A' and 'B' sets on send, will be as follows

Input to Pad	AF Output		
	<u>'A' set</u>	<u>IC amp</u>	<u>'B' set</u>
5v 400 cps	greater than 60 mw	greater than 600 mw	greater than 600 mw

RF & IF ALIGNMENT PROCEDURE AND SPECIFICATIONS

8. The procedure and specifications in Table 1 will be followed. The Generator signal RF AN/URM-25D and its associate leads, together with Impedance adaptor MX-1487/URM and isolating capacitor lead test CX-1363/U will be used for IF and RF measurements

TABLE 1

Step	Freq	Input to	Dummy Ant	Input Voltage	Output	Remarks
1. IF Sensitivity	465 kc	V2A grid (top cap)	as in para 6	60 to 120 uv	50 mw	Adjust L9, L8b, and L8a for maximum output (see para 9). Do not remove V2A grid cap
2 BFO Adjustment	465 kc	"	"	"	NA	Modulation OFF, NET switch S/C 105B ON adjust L5a for zero beat. (Headphone connected for this operation only).
IF BAND WIDTH check	465 kc	"	"	See para 10	NA	as detailed in para 10.
4. CAL and RF sensitivity.	8 mc 6 mc 5 mc	RCVR Ant	"	3 uv	50 mw	<u>High band</u> Calibrate at mc points, adjust C35A. RF sensitivity, adjust C10A at 8 mc (see para 11).
5. CAL and RF sensitivity	4 mc 3 mc 2 mc	RCVR Ant	"	3 uv	50 mw	<u>Low band</u> Calibrate at mc points, adjust C35B RF sensitivity, adjust C-10B at 4 mc (see para 11).

IF Sensitivity

9. The input voltage given in step 1 of Table 1 is only a guide and may vary depending on make of set. When adjustments have been made in step 1, check for undesirable peaks that may appear on either side of the top of IF response curve. This can be done by turning the signal generator slowly through the IF band and at the same time observing the AF output which should have only one peak. If a second peak occurs, adjust the bottom core of L8B slightly to reduce the unwanted peak.

IF Bandwidth Check

10. Note the input required for 50 mw output, double the signal generator output detune the generator above and below 465 kc, and note the two frequencies when the output again becomes 50 mw. The difference will be the IF bandwidth. Repeat operation with generator output increased 1000 times.

Specification.

- (a) Bandwidth will be greater than 6 kc at -6 db (double normal input).
- (b) Bandwidth will be less than 40 kc at -60 db, (1000 times normal input).

Calibration and RF Sensitivity

11. (a) The calibration of the 'A' set will be carried out with Frequency meter SCR-211 or equivalent. The allowable 'A' frequency MC dial error to be no more than ± 25 kc (1/4 division) from 2 to 7 mc.
- (b) Tune the receiver as in steps 4 and 5 of Table 1, peak the PA TUNE for maximum audio output. Reduce 'A' set AF gain until the output falls to 50 mw. This is 'signal plus noise' power and is equivalent to 22 db on the wattmeter. Switch the signal generator to cw and adjust the wattmeter range until a reading in db is obtained. This is the 'noise' power. The ratio of 'signal plus noise' to 'noise' (all in db) is the difference between the two readings.

Specification

- (c) With a 3 uv signal fed into set as in para 5 and 6, the sensitivity will be as follows:

$$\text{ratio} = \frac{S + N}{N} \text{ greater than } 15 \text{ db.}$$

Flick Adjuster Range Test

12. Set the FLICK ADJ to its centre position and feed in a cw signal with net switch on and phones in circuit.

- (a) The frequency shift, due to operation of the FLICK ADJ will not be less than

+ 700 cps at 2.0 mc
+ 900 cps at 4.5 mc
+ 3000 cps at 4.5 (HF band)
+ 3500 cps at 8.0 mc.

- (b) The frequency shift will not be more than

+ 1500 cps at 2.0 mc

- (c) The detent in the zero (central) position will be distinctly noticeable and the reset error at 4.5 mc on the LF band will not exceed + 230 cps.

'A' SET SENDER

13. The sender alignment procedure has been modified and simplified to make use of the standard type test equipment. The use of long leads and loose wire is not recommended for specification testing, therefore the cables and leads provided with the new test equipment will be used as laid down in this instruction.

Drive Alignment

14. The following procedure is laid down for the correct alignment of the drive circuits.

- (a) Adjust sender as in para 5 and 6.
- (b) Tune sender to 7.8 mc.
- (c) Set C34A to maximum capacity (line up the two spots of solder on face of trimmer).
- (d) Adjust R34A to give 40v+ on pin 4 of V6A.
- (e) Ground junction of R1E and R1D (adc line).
- (f) Adjust drive trimmers C10C and C10B for maximum drive as read on panel meter.

15. To ensure correct adjustment, ground pin 5 of V2B (bfo grid). The drive, read on panel meter, should fall almost to zero. If the drive reading increases, C10C and C10B are incorrectly set. To correct this error, tune sender to 5 mc and readjust C10C and C10B for maximum drive reading on panel meter. Tune sender again to 7.8 mc and readjust drive trimmers C10C and C10B for maximum as in para 14(f). Verify this adjustment again by grounding pin 5, V2B, and observing drive reading.

16. Remove adc ground and check drive reading across the band. The drive as read on panel meter to be $7v \pm .5v$ and must remain steady as sender is tuned across the band. Maximum variation permissible is one division on panel meter.

17. Switch to low band and carry out the following steps.

- (a) Tune sender to 4.5 mc.
- (b) Ground the junction of R1E and R1D.
- (c) Adjust C10E and C10F for maximum drive reading on panel meter.
- (d) Check for correct adjustment by grounding pin 5 of V2B, and drive reading should drop to practically zero. If drive reading increases tune sender to 2.5 mc and readjust C10E and C10F for maximum. Return sender to 4.5 mc and again adjust C10E and C10F for maximum drive reading on panel meter.
- (e) Remove adc ground and check drive reading across the band. The drive as read on panel meter to be $7v \pm .5v$ and must remain steady as sender is tuned across the band. Maximum variation permissible is one division on panel meter.

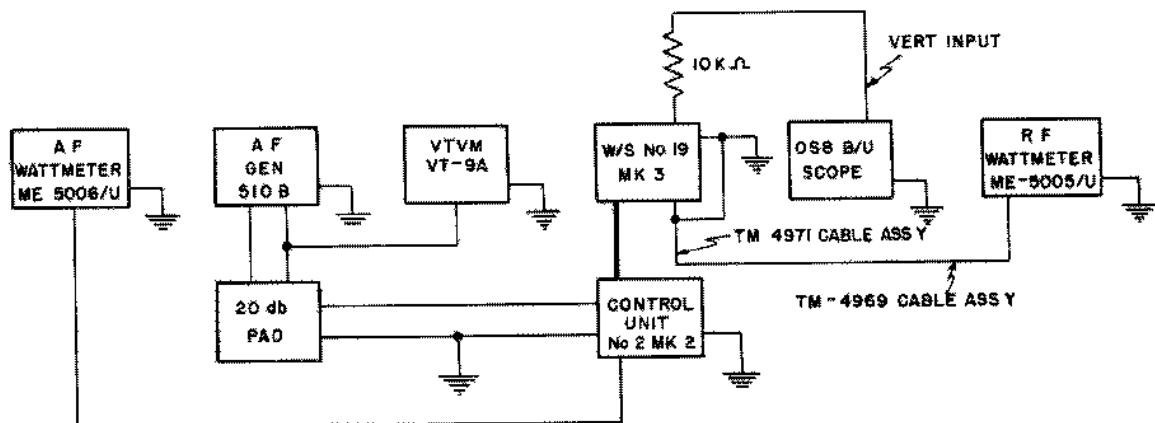

DEME 88606

Fig 2 - Test equipment connections for complete sender tests

Modulation Check

18 The oscilloscope, unless properly connected and set up, will present a misleading picture. The setting of the step attenuators and variable gain controls on both vertical and horizontal inputs are critical, especially when checking for distortion on a modulated wave as detailed here. A few other important considerations are

- (a) Read Elec Y 832/1.
- (b) Use shielded leads for all measurements.
- (c) Ensure a good common ground between oscilloscope and equipment under test.
- (d) Do not overload the oscilloscope amplifiers
- (e) Use as little sync voltage as possible to stabilize pattern.

19 Replace the dummy PA tube, V4A, with a serviceable 807 and connect set and test equipment as in Fig 2. Tune the sender to 2.2 mc with maximum output on CW, and adjust the oscilloscope for the pattern shown in Fig 3A. Switch to RT and modulate the carrier with 400 CPS. Synchronize the pattern until a stable picture is obtained, Fig 3B. Set the input to the 20db pad to .3v and adjust R43A for maximum undistorted output. The modulated carrier, as determined on the oscilloscope using the graduated scale, will be in the order of 40 per cent (Fig 3B). Switch to MCW, and adjust oscilloscope for pattern at Fig 3C. The modulation patterns shown in Fig 3A, B and C will be produced on the oscilloscope with a properly connected and adjusted set. The pattern shown at Fig 3D is an AM wave, modulated over 100 per cent.

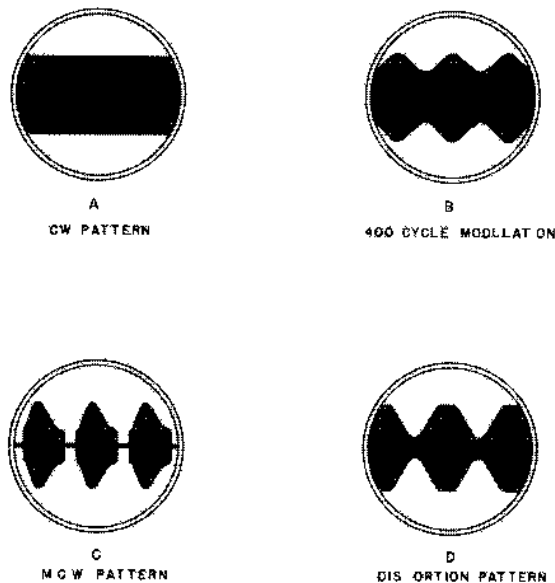

DEME 88567

Fig 3 - Oscilloscope modulation patterns

Sender Power Output

20 Connect the 'A' sender as in Fig 2, and tune it for maximum RF output at 2.4 and 6 mc The RF output will not be less than is indicated below.

Specification

Frequency	6 mc		2.4 mc
System switch	RF Power Output		
RT	3 watts	2	2 watts
CW	12. watts	10.	watts
MCW	4 watts	3.	watts

21. The ratio of sender output RT to CW should be in the order of 1 to 4. If this ratio is found otherwise, the bias on V4A in the RT setting may be faulty. Check bias circuit of PA stage, resistor R/C-104A and bypass capacitor C/C-107A.

Transit-Receiver Tracking Error

22. On send zero beat the sender with a frequency meter at 6 mc and 3.5 mc. Return set to receive and switch to NET. The difference beat note heard in receiver headphones will not exceed 750 cps at 6 mc and 350 cps at 3.5 mc judged aurally.

Dial Flick Reset Accuracy

23 While switched to NET, set up both flick mechanisms red flick at 6 mc, and blue flick at 4 mc, and zero beat with the frequency meter. Rotate tuning dial away from flick positions, set flick levers, and rotate until the detent operates The beat note heard in receiver headphones will not exceed \pm kc.

'B' SET

Data

24 The 'B' set tests will be carried out with 12v LT as measured on pin 10 plug PL 2A, with the 'A' set and 'IC' switched off

Quench Oscillator

25. Loosely couple the Frequency meter SCR-211 into quench oscillator circuit and check frequency range of oscillator. The frequency range of quench oscillator must be between 160 and 220 kc, as adjusted by the slug on front panel of 'B' set. Adjust and leave oscillator frequency at approximately 170 kc.

'B' Set Calibration

26 Feed a modulated signal at 235 mc to the antenna post, using a calibrated Generator Signal Adv Comp D1. Tune 'B' set dial for maximum output on the AF wattmeter. 'B' set dial should read between 4 and 6. When necessary, calibrate by spreading or compressing L11A.

'B' Set Sensitivity

27 With connections as in para 26, adjust signal generator output attenuator for a 10 uv input signal. Adjust 'B' set receiver for maximum output on the AF wattmeter and reduce AF gain control for 50 mw output. Switch the signal generator to cw and check the signal plus noise-to-noise ratio. This ratio will be greater than 10 db as read on the wattmeter with no headphones in circuit.

'B' Sender Power Output and Modulation Check

28. Connect the 'B' set via cable assemblies TM 4971 and TM 4953, to wattmeter RF ME-5005/U. On send, the output as read on RF wattmeter will not be less than 2w as sender is tuned from 1 to 10.

29. Apply a 400 cps signal at 1.0v into 20 db pad (Fig 2). The increase in sender output with modulation will not be less than .3w.

NOTE

The receiver radiated output from the super-regenerative detector will be less than .05w, as read on wattmeter RF, 'B' set on receive.

SUPPLY UNIT

Lubrication

30 The dynamotor bearings should be lubricated with 3-GP-641A grease (Elec F 250/3 Instr 1)

Commutator Repairs

31. No repair is required on a smooth, well-burnished chocolate-colored commutator. When new brushes are installed they should be properly seated using MT/55800 Stones brush seating.

32. To resurface a 'scored' commutator, turn on a lathe, and undercut as required. Light scores can be removed using 1F 309923 Stick commutator resurfacing, medium grade. Always use 1F 309924 Stick commutator resurfacing, polish grade, to finish the job.

33. The resurfacers and brush-seating stones should be pressed firmly against the commutator and moved slowly from side to side. This should be done with the machine running at full speed. Although the stones are good insulators, use the necessary safety precautions when working on high voltage commutators. REMOVE ALL ABRASIVE DUST,

Load Ratings

34. The dynamotor load ratings are:

265 v winding	- 2,200 ohms
540 v winding	- 20,000 ohms.

The vibrator load rating is 2,200 ohms.

(Note Maximum continuous plate current for JAN OZ4A/1003 is 130 mA.)

Output Voltage

35. The output voltage under rated load should be within the following limits

(a) HT1 Vibrator	- 265 v \pm 10%
(b) HT1 Dynamotor	- 265 v \pm 5%
(c) HT2 dynamotor	- 540 v \pm 5%

Input Current

36 The input current should not exceed the following

(a) No load vibrator	- 0.75 amp
dynamotor	- 5.5 "
(b) Rated load vibrator	- 2.5 amp
dynamotor 12 v operation	10 amp
dynamotor 24 v operation	7 amp

Ripple Voltage

37 The ripple voltage measured with a 1,000 ohms per volt ac meter connected in series with a 2 uf capacitor should not exceed

HT 1 - vibrator or dynamotor	- 0.2%
HT 2 -	- 0.75%

Functional Operation

38. Connected to a wireless set No. 19 the supply unit will perform all required operations and will operate satisfactorily with any supply voltage from 10 to 16 v for 12 v operation or from 20 to 32 v for 24 v operation. The unbalance on 3 wire 24 v operation should not exceed 1.5 amp. The set will operate on a 24 v two wire system.

39. Check relay SC 103A and the DYN-OFF-V1B switch for dependable operation.

VARIOMETER

40. Connect the wireless set No. 19 Mk 3 to the variometer and to the wattmeter rf in series with C_1 a 50 uuf 300 v condenser (Fig 9).

41. Tune the set and variometer for maximum output at 6 mc and 2.4 mc. The sender output will be the same as in para 20.

42. The variometer must rotate smoothly and be capable of tuning for maximum rf output from 2 to 8 mc and yet remain outside the red portion of the scale. All switching points must be at least one division inside the red portion (see para 52, 53, and 54).

NOTE

When the variometer is fitted with the new type adapter plate 1Z-ZA-44722 PLATE, the sender output is reduced by approximately 20 per cent.

R29A Adjustment

43. Connect variometer as in Fig 9 and remove adjustment knob. Switch to CW and meter switch to aerial current. Tune the sender for maximum output at 6 mc, and adjust R29A for a reading on the panel meter (15 v scale) of 1.0 volt per watt output as read on the RF wattmeter. Seal adjustment with glyptol, and re-assemble, being careful with the calibration of variometer. If difficulty is experienced in assembly or calibration of variometer, refer to "Alteration of Variometer Window Position" para 52.

MECHANICAL REPLACEMENT AND ADJUSTMENTS

44. Relay, S5A and B

- (a) To lift the relays for inspection, remove the two bolts and the screw holding the bracket to the chassis.
- (b) To remove a relay from the set, undo bracket as described above, remove two screws holding the relay to the bracket, unsolder the connecting leads, tag to facilitate replacement.

- (c) To change a solenoid, remove bracket as described in (a) above, remove screws holding armature to relay and remove the armature. Unscrew the nut holding the solenoid to the relay and unsolder the wires to the solenoid.

Band Switch S11A

45. To withdraw the switch shaft, remove the switch knob and the access panel from the set front panel, then remove two screws holding the click plate to the sender RF screening can. Withdraw the switch shaft.

When replacing the shaft, ensure that the bakelite washer is fitted between the switch wafer and the switch shaft groundingspring in the sender RF screening can. Replace the click plate pillars in the correct way, also ensure the phenolic insulating washers are replaced. When a wafer has been replaced, align the wiper before the switch shaft is inserted (Fig 1).

System Switch S7A

46. To replace a wafer, or change S7A, unsolder the short leads from V4A tube holder assembly, remove the two screws from the corners of this assembly and swing it clear leaving the long leads attached. Undo the switch from the front panel, unsolder and tag accessible connections, turn the switch and progressively unsolder such wires as are necessary to replace a wafer or the complete switch.

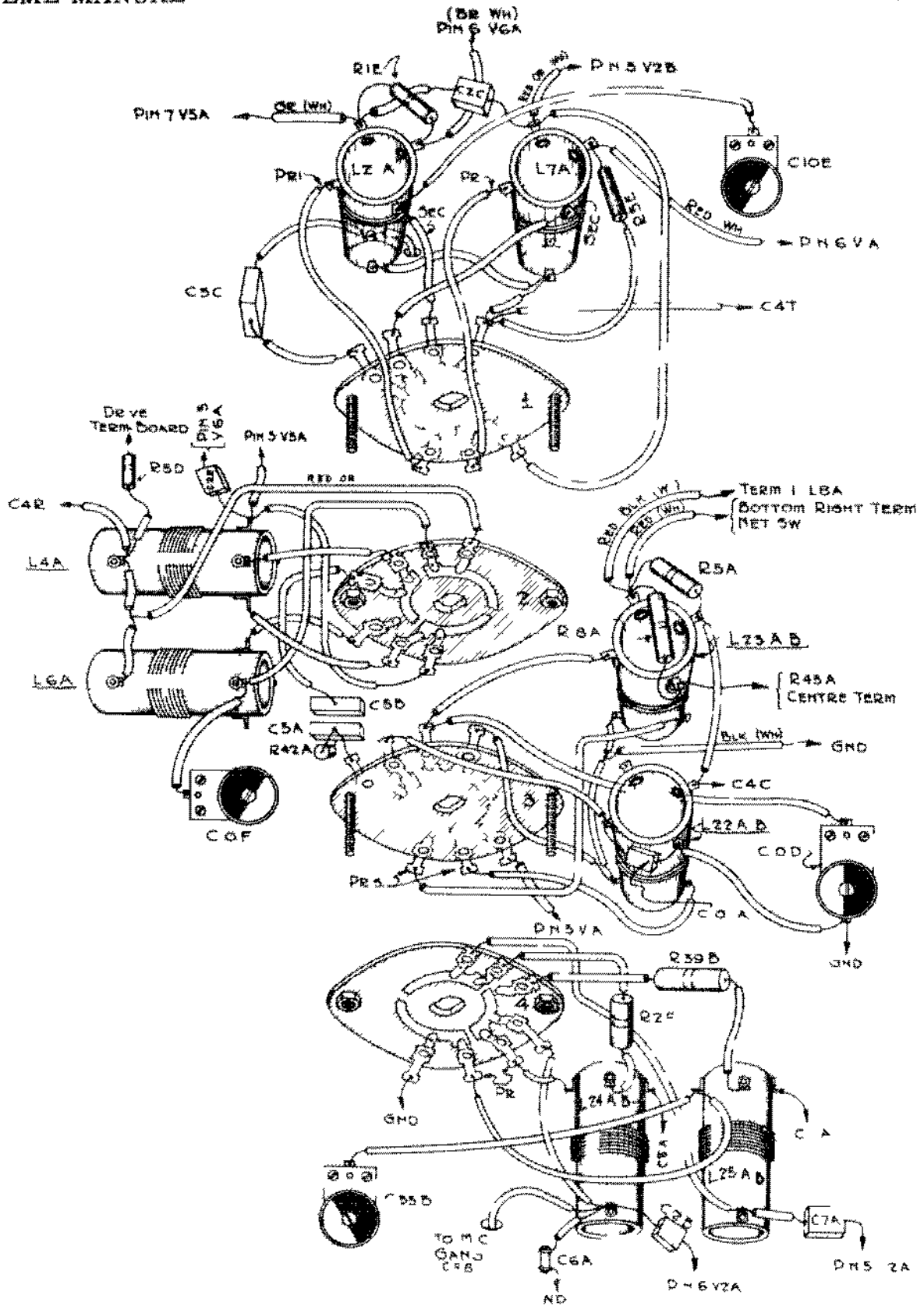

Fig 4 (b) - S11A band switch and associated coils (Northern Electric Co)

PA Tuning Capacitor and Drive Assembly

- 47 To remove or replace the PA capacitor C3A, and drive assembly (Fig 7)
- (a) Turn the TUNE -SET-FLICK lever to SET and remove the four flick locking screws from the PA dial knob
 - (b) Remove the index bracket
 - (c) Remove screw 'P' from the pivot at the left of the slow motion drive assembly. The spring and 'C' washer may now be removed. The slow motion drive may also be removed by sliding it to the left so that its actuating stud slides out of the slot in the flick operating arm behind the front panel
 - (d) Remove the large centre fixing bolt 'C' and washer from the hub of the dial knob
 - (e) Loosen the radial grub screw in the side of the dial knob
 - (f) Remove the dial knob by pulling forward
 - (g) Remove the two fixing screws from the dial stops. These go right through the front panel into the flick mechanism case ('dial mounting plate')
 - (h) Remove the TUNE SET FLICK lever by removing the hub fixing screw marked 'H', loosening the radial grub screw and pulling the lever forward
 - (i) Remove the two screws securing the lower right and left hand corners of the dial mounting plate to the chassis base
 - (k) Unsolder the red lead at AERIAL A socket
 - (l) Unsolder the heavy bus from the terminal on the ceramic socket on top of the PA capacitor C3A. This bus leads to the PA terminal board at the rear of C3A
 - (m) Unsolder C36A ground lead from C3A frame
 - (n) Remove the screw securing the brackets on which are mounted L3A and C36A
 - (o) Remove V3A. Remove three screws and spacers securing the PA resistor board to the rear of the PA tuning capacitor

- (p) Move L3A, C36A, and the PA resistor board towards the rear of the set to allow sufficient working room.
- (q) Remove V5A.

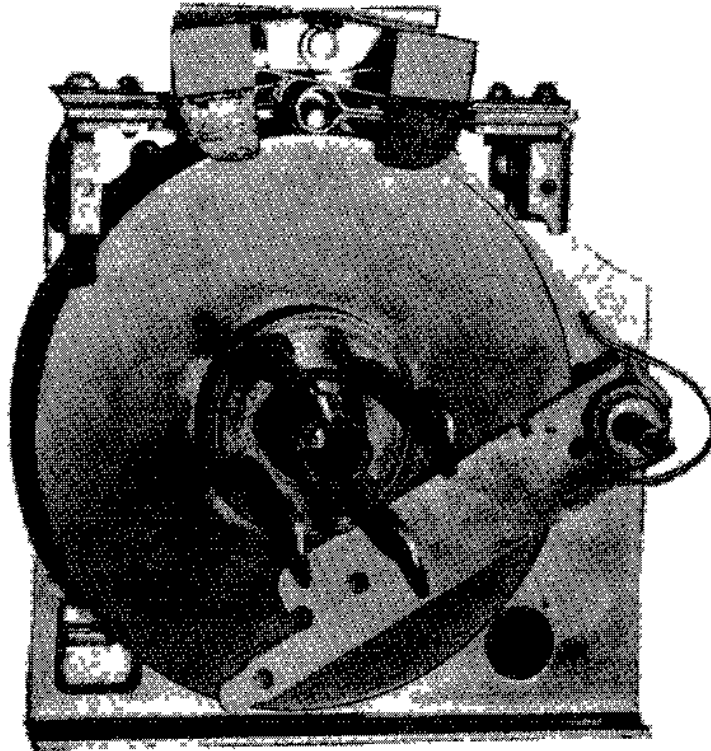
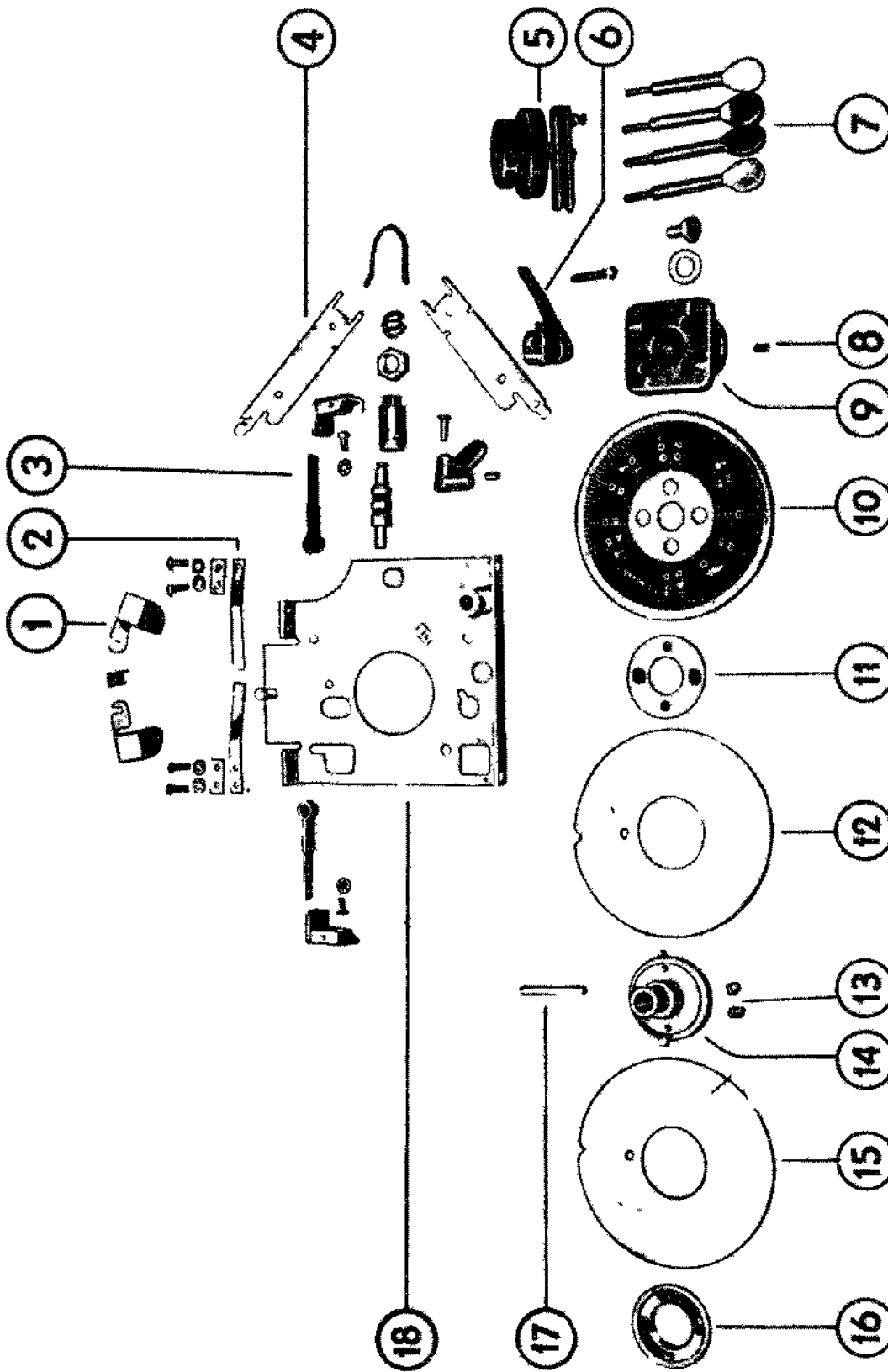

Fig 5 - Flick mechanism assembly



- | | | |
|----------------------------|------------------------------|-----------------------------|
| 1- INDICATOR, Flap, Right. | 7 - SCREWS, Dial Clamping | 13- SCREW, Grub. |
| 2- SPRING, Flick Arm. | 8 - SCREW, Grub | 14- BOSS, Disc. |
| 3- ARM, Flick | 9- KNOB, No 2 | 15- DISC, Flick. |
| 4- ARM, Operating, No 1. | 10- DIAL. | 16- WASHER, Clamping, Rear. |
| 5- SLOW MOTION DRIVE. | 11- WASHER, Clamping, Front. | 17- PIN, Taper. |
| 6- BRACKET & SPRING. | 12- DISC, Flick | 18- PLATE, Dial Mounting. |

Fig 6 - Flick mechanism components

- (r) Push the PA tuning capacitor and the flick mechanism unit to the rear and lift out.
- (s) Replace in reverse order.

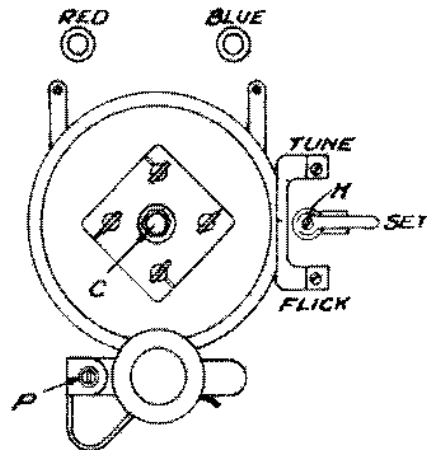

Fig 1 - Dial mechanism

48. To remove the PA tuning capacitor from the flick mechanism.
- (a) Complete the steps outlined in para 47.
 - (b) Remove the four screws retaining the two flat flick arm springs located on top of the PA dial mounting plate (2 screws to each spring). Remove washers, spacers, and flick springs.
 - (c) Remove the two flick indicator flaps and spring.
 - (d) Remove the two flick operating arms and spring.
 - (e) Remove the taper pin from the drive mechanism boss. It may be extracted only in one direction due to the taper.
 - (f) Remove the flick clamping washer, noting position of assembly.
 - (g) Remove flick disc, noting position of assembly.

- (h) Remove the radial grub-screw securing boss, and then remove the boss by pulling it off the tuning capacitor shaft. Note position of assembly.
- (j) Remove second flick disc and clamping washer, noting position of assembly.
- (k) Remove the PA tuning capacitor by removing three screws securing it to the dial mounting plate.

MC Gang Capacitor and Drive Assembly

49. To remove and replace the MC gang capacitor and drive assembly (Fig 7)
- (a) Proceed as detailed in para 47(a) to (j).
 - (b) Remove tubes V2B, V1A, V2A, V1B, V1C, V3A, V5A, and V6A.
 - (c) Remove the angular metal shield on which T3A is mounted by removing the following screws
 - (1) Two screws above T3A to the MC gang case.
 - (11) One screw below T3A to chassis.
 - (111) Two screws at rear of set to the vertical chassis wall.
 - (d) Remove the coaxial tube to the grid cap of V2B by removing:
 - (1) One retaining screw on top of the MC gang case.
 - (11) One retaining screw at the rear of the MC gang case.
 - (e) Remove two ground braids from the MC gang case to chassis (where applicable).
 - (f) Unsolder two leads from the FLICK ADJ coil, L/C-103A.
 - (g) On the underside of the chassis, unsolder the four leads which feed through, one to each MC gang capacitor section.
 - (h) Uncouple the FLICK ADJ flexible shaft by loosening the first grub screw where the flexible shaft enters the FLICK ADJ assembly.
 - (j) Remove 'C' washer from the FLICK ADJ control shaft and pull on the FLICK ADJ knob to remove the entire shaft assembly via the front panel.

- (k) Remove five screws from beneath the chassis base, retaining the MC gang case in position. The position of these screws is easily determined by observation.
- (l) The MC gang capacitor, case, and drive mechanism may now be removed as a complete unit.
- (m) Should any undue difficulty be encountered in step (l) above, remove the RF GAIN control, the AVC switch and the NET switch to allow more working room. The coaxial tube may be removed, if necessary, by unsoldering the lead from its terminal beneath the chassis near the socket of V1B. L8B may be easily removed, if required. However, it should not be necessary to remove any of the above components.
- (n) Replace in reverse order.

50. Stripping the flick mechanism is accomplished exactly as for the PA assembly outlined in para 48, except that the boss (para 48(h)) has two grub screws.

Reassembling the Flick Mechanism

51. In general, reassembling the flick mechanism is merely the reverse of the stripping instructions. However, the following important points should be noted when replacing the clamping screws, flick discs, etc:

- (a) The first flick clamping washer to be replaced should have its flat side to the rear and its two small tapped holes in the vertical plane.
- (b) The first flick disc to be replaced should have its projecting stud to the front, and its periphery slot to the top.
- (c) The boss is replaced with its two large, untapped holes in the vertical plane lining up with the vertical tapped holes mentioned in (a.) above. Make certain that the radial holes drilled through the boss hub lines up with the equivalent hole through the drive shaft, to receive the taper pin. The two flanges protruding from the periphery of the boss should point downward like an inverted 'V' when the PA capacitor is held closed. Should these flanges point upward, a 180 deg error has been made when sliding the boss on the drive shaft.
- (d) The second flick disc should be replaced with its projecting stud to the rear, and its periphery slot to the top.
- (e) The second flick clamping washer should now be replaced with its flat side to the front, and its two large holes in the vertical plane, lined up with the two large untapped holes in the boss (see (c) above).

- (f) The taper pin should now be firmly driven into its position through the boss hub and drive shaft. Tighten radial grub screws.
- (g) Replace two flick operating arms and spring. Replace the two flick arms, springs, indicator flaps, etc.
- (h) The dial and knob are added after the drive mechanism is mounted in the chassis. Make certain that the three shallow studs on the front face of the dial are properly seated in the receptacles provided on the inner face of the hub. Do not forget to tighten the central fixing screw before tightening the grub screw.
- (j) When replacing the slow-motion drive, make certain that the stud is inserted through the panel and secured in the slot of the lower flick operating arm. Add dial spring and securing screw to this assembly. Using leverage, bend this spring so that its stud catches in the small hole drilled through the panel, then tighten screw. This retains proper tension on the spring. Do not forget the small 'C' washer between the spring and the panel.
- (k) When replacing the four flick locking screws it is necessary that the holes in the boss and the two clamping washers be properly lined up as described in this paragraph otherwise the screws will not go fully home and cannot be secured.
- (l) Later models have small spring retaining wires to prevent flick locking screws from accidentally falling out if loosened too far.

Alteration of Variometer Window Position

52. To change the position of the variometer window to one which allows the scale to be more easily read

- (a) Note the number stamped on the case over the fixing screw nearest the position chosen.
- (b) Loosen the eight screws marked 'F' (Fig 8) and remove the end cover.
- (c) Loosen the four screws marked 'C' and turn the scale 'S' so that the internal number opposite the pointer 'P' corresponds to the number noted in (a) above.
- (d) Tighten the four screws marked 'C' until a stiff but smooth movement of the knob is obtained.
- (e) Rotate the knob until the pointer 'P' is opposite the hair line in the centre of the index window.

- (f) Bring the coupling fork 'Y' opposite the number on the outer case corresponding to the internal number indicated by pointer 'P'.
- (g) Carefully replace the end cover on the variometer case so that the centre line of the index window is opposite the desired number on the outer case.
- (h) Tighten the eight screws marked 'F'.
- (j) Test the motion and action of the variometer.

CAUTION The sequence outlined in para 52 above must be followed carefully since improper assembly will result in the internal variometer series parallel switching not being in the changeover position when red shows in the window.

Adjustment of Variometer Tuning Knob Movement

53. If the variometer tuning knob becomes too loose or too tight, it may be adjusted as follows.

- (a) Remove the variometer end cover as described in para 52.
- (b) Adjust the screws marked 'C' (Fig 8) until a satisfactory stiff, smooth movement of the control knob is obtained.
- (c) Seal screws with varnish or service cement.
- (d) Replace the end cover as in para 52.

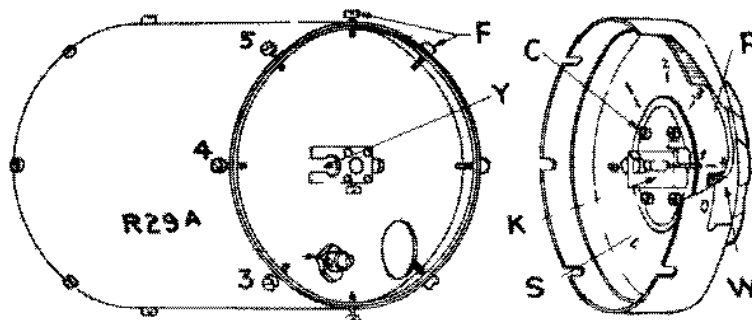
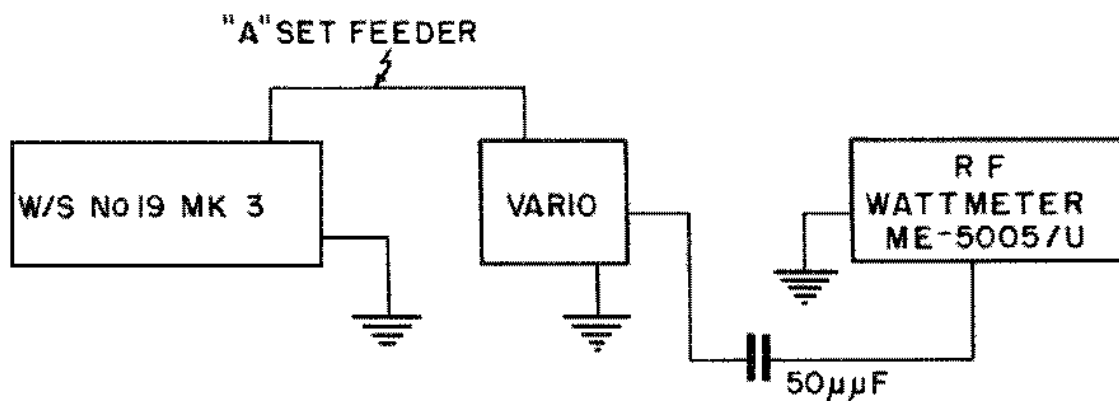

Fig 8 - Detail of variometer

Replacing Cork Friction Discs in Variometer

54 To check the operation of the series-parallel, changeover contacts, listen carefully on the receiver headgear with the Wireless Set No. 19 operating on Receive in a normal installation. The absence of any undue load clicks in the headphones, while rotating the variometer knob slowly indicates that the changeover contacts are operating smoothly.

55 Relay and switch contacts are of the self-wiping type and should seldom give trouble. If high resistance occurs, clean with trichlorethylene. Do not use an abrasive, when badly burned or pitted replace.



DEME 88605

Fig 9 - Variometer test connections

Microphone and Receiver Insets

57. Insets, microphone, moving coil No. C1, as fitted to Microphones, hand, No. 7 and Microphones, hand Cdn Type 2 are generally not repairable since they are sealed in a case which must be destroyed to remove the diaphragm and moving coil.

Dynamotor

To remove the dynamotor from supply unit No. 2

58. Remove the case, spare tube, and vibrator, unsolder and tag the two field winding leads, remove the screws from the brush holders and move the wires out of the way, remove the two top front bolts securing panel and frame, if necessary move C4CP and clamp to give access to the top left hand bolt, remove the two countersunk screws from the back main upright, remove the left side plate and the bottom screw from the right side plate, remove the four dynamotor platform bolts. At the rear, lift the top of the frame and slide the dynamotor clear.

59. Replacement is made in the reverse order.

PL 23 12 POINT POWER PLUG	
1	12V
2	12V
3	12V
4	12V
5	12V
6	12V
7	12V
8	12V
9	12V
10	12V
11	12V
12	12V

PL 24 12 POINT COMBINATIONS PLUG	
1	12V
2	12V
3	12V
4	12V
5	12V
6	12V
7	12V
8	12V
9	12V
10	12V
11	12V
12	12V

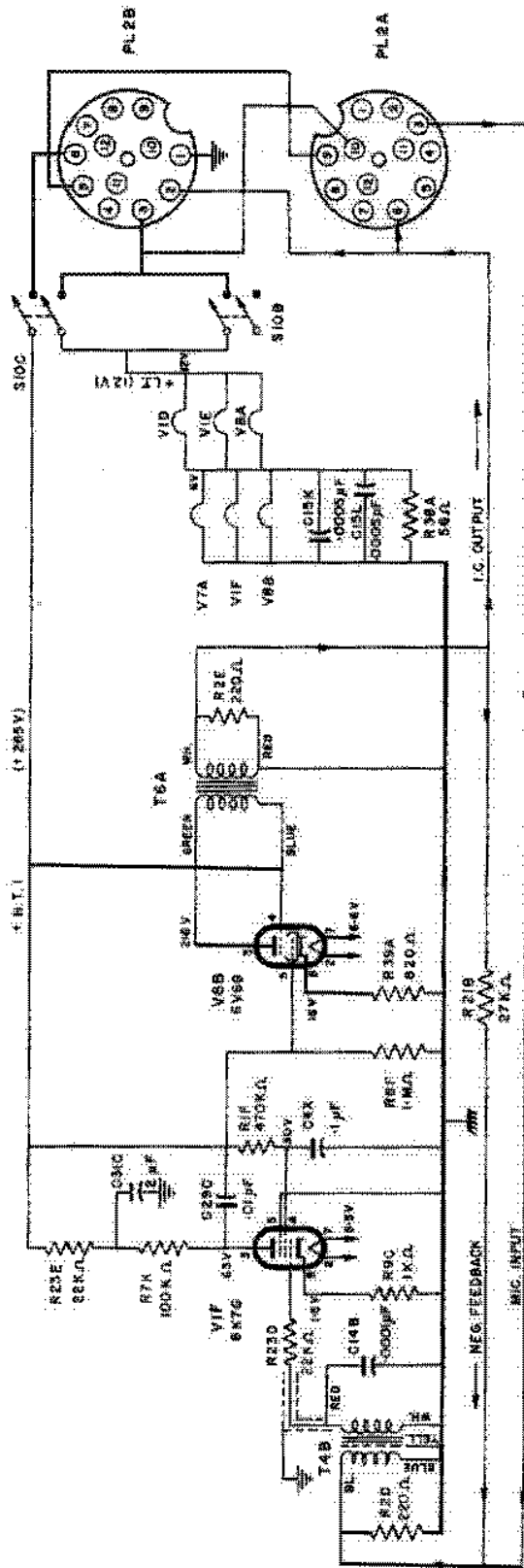

DEME 88603
Fig 1004 - Schematic IC amplifier

CANADIAN ARMY
EME MANUAL

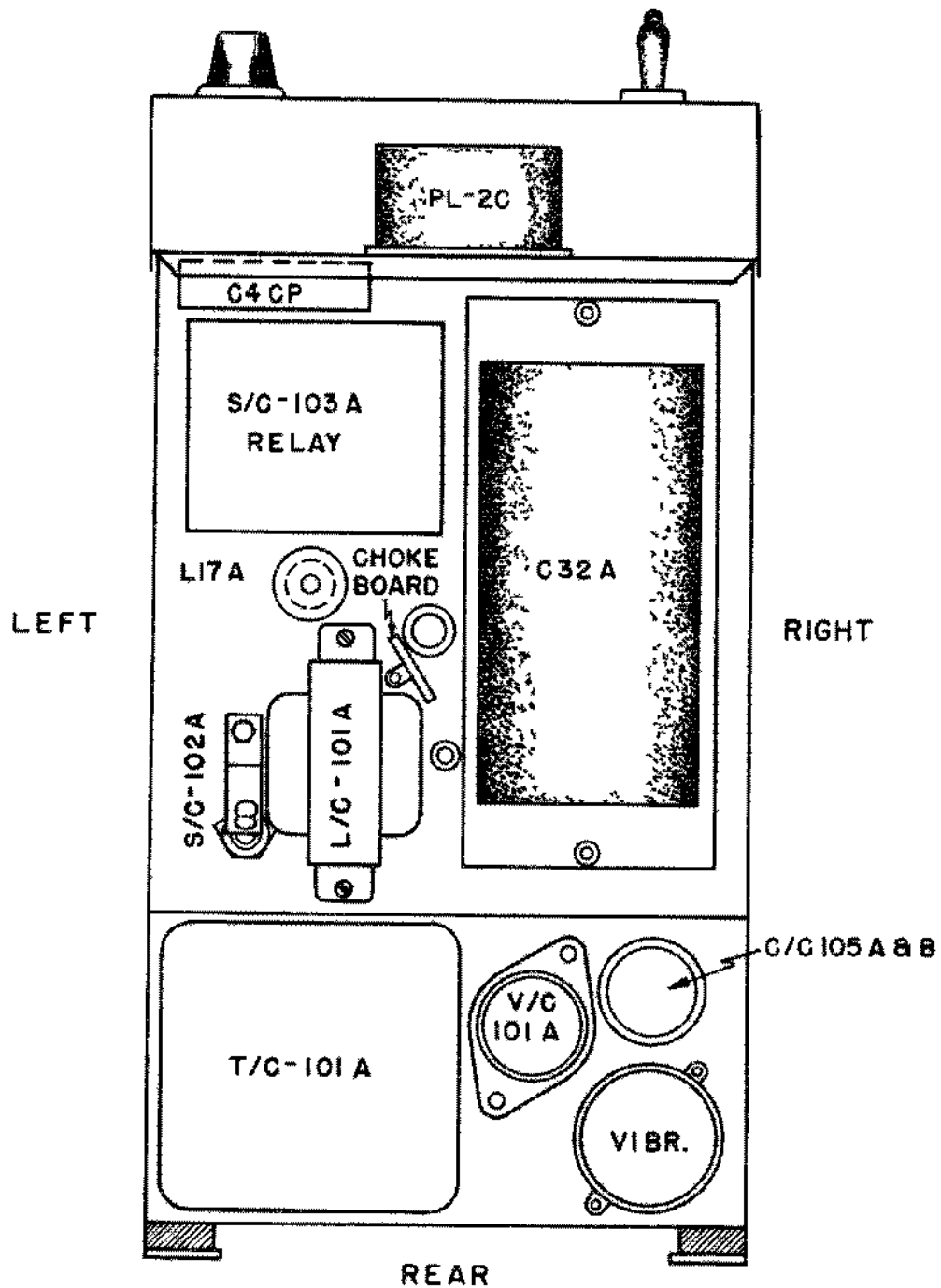

DEME 88608 (Top view)

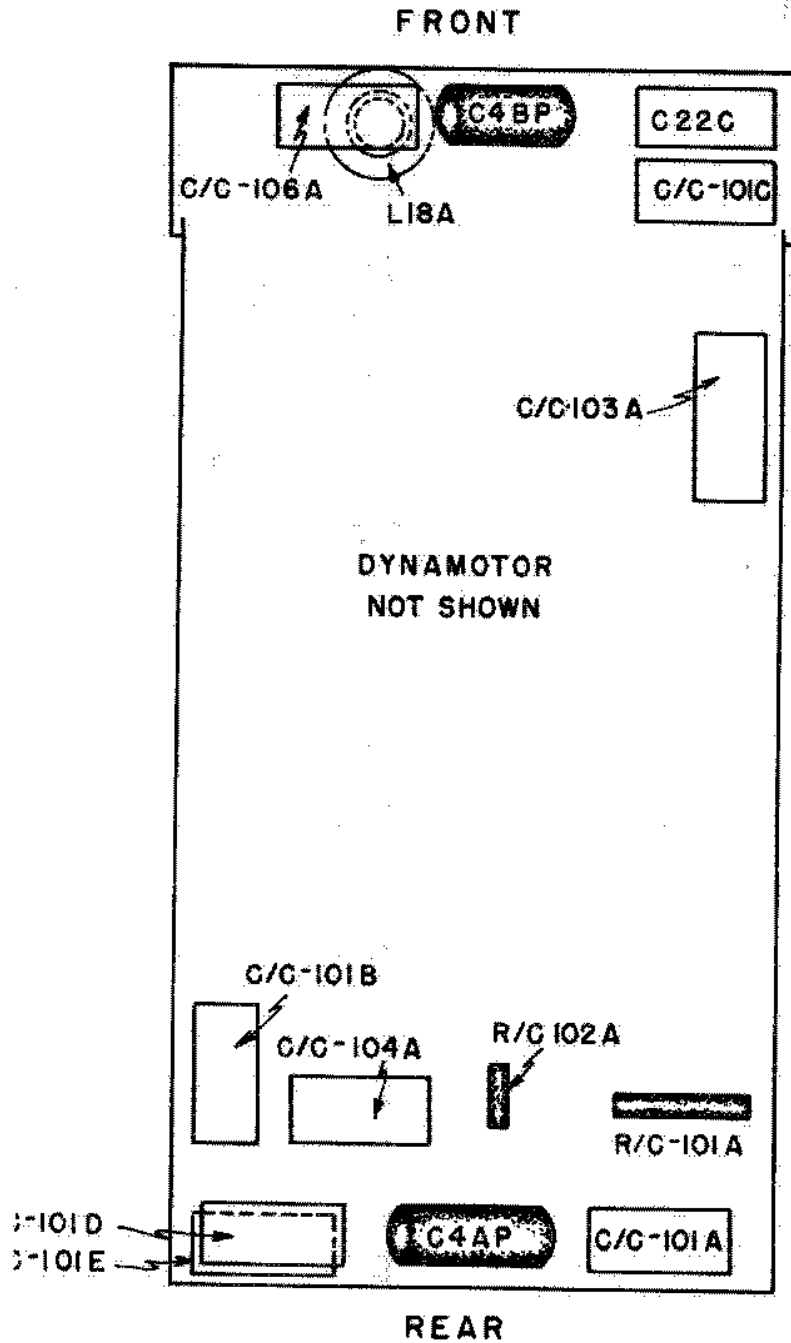

DEME 88607 (Bottom view)

Supply unit No. 2

END