

**Crown Copyright Reserved.**

**Army Code No. 13120**

*Incorporating  
Amendment No 1*

**RESTRICTED**

The information given in this document  
is not to be communicated either directly  
or indirectly to the Press or to any person  
not authorised to receive it.

**USER HANDBOOK**  
**for**  
**STATION RADIO A13**

**REVISED EDITION**

**PUBLISHED UNDER THE AUTHORITY OF  
THE SIGNAL OFFICER-IN-CHIEF (ARMY)  
THE MINISTRY OF DEFENCE  
WHITEHALL S.W.1.**

**JANUARY 1966**

## C O N T E N T S

### CHAPTER I - GENERAL DESCRIPTION

Section	1	Page
1	Facilities .. .. .	1
2	Kits in which SR A13 is supplied .. .. .	2
3	Composition of manpack No. 1 .. .. .	5
4	Composition of manpack No. 2 .. .. .	7
5	Composition of one-man high power manpack .. .. .	7
6	Composition of third man load .. .. .	9
7	Spare battery packs .. .. .	10
8	Power supply .. .. .	11
9	Audio facilities .. .. .	12
10	Weights and dimensions .. .. .	13

### CHAPTER 2 - OPERATION

11	LP manpack station .. .. .	15
12	HP manpack station with Mk 1 amplifier .. .. .	18
13	HP manpack station with Mk 2 amplifier .. .. .	20
14	Assembly of manpack No. 2 .. .. .	22
15	LP ground station .. .. .	25
16	HP ground station .. .. .	26
17	Checking battery voltage .. .. .	29
18	Tuning TR A13 .. .. .	29
19	Adjusting the tuner RF .. .. .	33
20	Tuning the HP station with Mk 1 amplifier .. .. .	35
21	Tuning the HP station with Mk 2 amplifier .. .. .	36
22	Searching and netting .. .. .	37
23	Antennas .. .. .	39
24	Remote control .. .. .	44
25	Direct operation from an external 12V battery .. .. .	45

### CHAPTER 3 - BATTERY CHARGING

26	Stabiliser voltage .. .. .	47
27	Hand generator .. .. .	48
28	Charger battery .. .. .	50

### CHAPTER 4 - VEHICLE INSTALLATION

29	Using the harness adapter .. .. .	53
30	Kits required .. .. .	55
31	Moving VHF radio sets .. .. .	58
32	Fitting harness adapter and SR A13 .. .. .	59
33	Fitting J1 and LT box .. .. .	61
34	Fitting antenna base and lead .. .. .	61
35	Connectors for SR A13 HP with Mk 1 amplifier .. .. .	65
36	Connectors for SR A13 HP with Mk 2 amplifier .. .. .	67
37	Stabiliser voltage .. .. .	68
38	Operating SR A13 with harness adapter .. .. .	70
39	Stowing unused equipment .. .. .	70
40	Using the clip-on kit .. .. .	72
41	Contents of the clip-on kit .. .. .	73
42	Fitting the clip-on kit in an FFR truck .. .. .	74
43	Framework and antenna bracket kit for a Rover cargo truck	76

Section 44	Fitting the framework and antenna bracket kit ..	Page 77
45	Fitting the clip-on kit on the framework .. ..	78

CHAPTER 5 - SERVICING

46	Servicing tasks .. .. .	79
47	Operator's servicing .. .. .	79
48	Technician's servicing .. .. .	79
	Test Charts .. .. .	80-85

I L L U S T R A T I O N S

Fig.No.	1	TR A13 .. .. .	Page iv
	2	Items forming manpack No. 1 .. .. .	4
	3	Items forming manpack No. 2 .. .. .	6
	4	Items forming third man load .. .. .	8
	5	Stabiliser and spare battery pack .. .. .	10
	6	Method of attachment to the manpack frame .. ..	14
	7	Low Power manpack station .. .. .	16
	8	Battery strap assembly' .. .. .	17
	9	High power manpack station with Mk 1 amplifier ..	18
	10	High power manpack station with Mk 2 amplifier ..	20
	11	Manpack No. 2 assembly with Mk 1 amplifier .. ..	22
	12	Manpack No. 2 assembly with Mk 2 amplifier .. ..	23
	13	Low power ground station .. .. .	24
	14	High power ground station .. .. .	26
	15	TR A13 controls .. .. .	28
	16A	Sequence of tuning .. .. .	30
	16B	Sequence of tuning .. .. .	31
	17	Tuner RF controls .. .. .	33
	18	Mk 1 amplifier controls .. .. .	34
	19	Mk 2 amplifier .. .. .	36
	20	8-ft. whip antenna and counterpoise .. .. .	40
	21	26-ft. vertical antenna .. .. .	41
	22	Dipole antenna .. .. .	42
	23	End fed antenna .. .. .	43
	24	Connecting the Mk 2 amplifier to two vehicle batteries	45
	25	Battery charging from vehicle batteries .. .. .	46
	26	Battery charging with the hand generator .. ..	49
	27	Battery charging with the charger battery .. ..	51
	28	Table drilling diagram .. .. .	58
	29	Harness adapter installed with SR A13 and Mk 1 amplifier	60
	30	Making the vehicle antenna lead .. .. .	62
	31	Fitting the antenna base .. .. .	63
	32	Connector diagram - Mk 1 amplifier .. .. .	64
	33	Harness adapter with SR A13 and Mk 2 amplifier ..	66
	34	Connector diagram - Mk 2 amplifier .. .. .	67
	35	Stabiliser mounted on framework .. .. .	68
	36	Connecting the stabiliser via the LT box .. ..	69
	37	Hand generator stowed on framework .. .. .	71
	38	SR A13 HP with clip-on kit in an FFR truck .. ..	75
	39	Angle framework and antenna bracket .. .. .	77
	40	SR A13 LP with clip-on kit in modified cargo truck	78

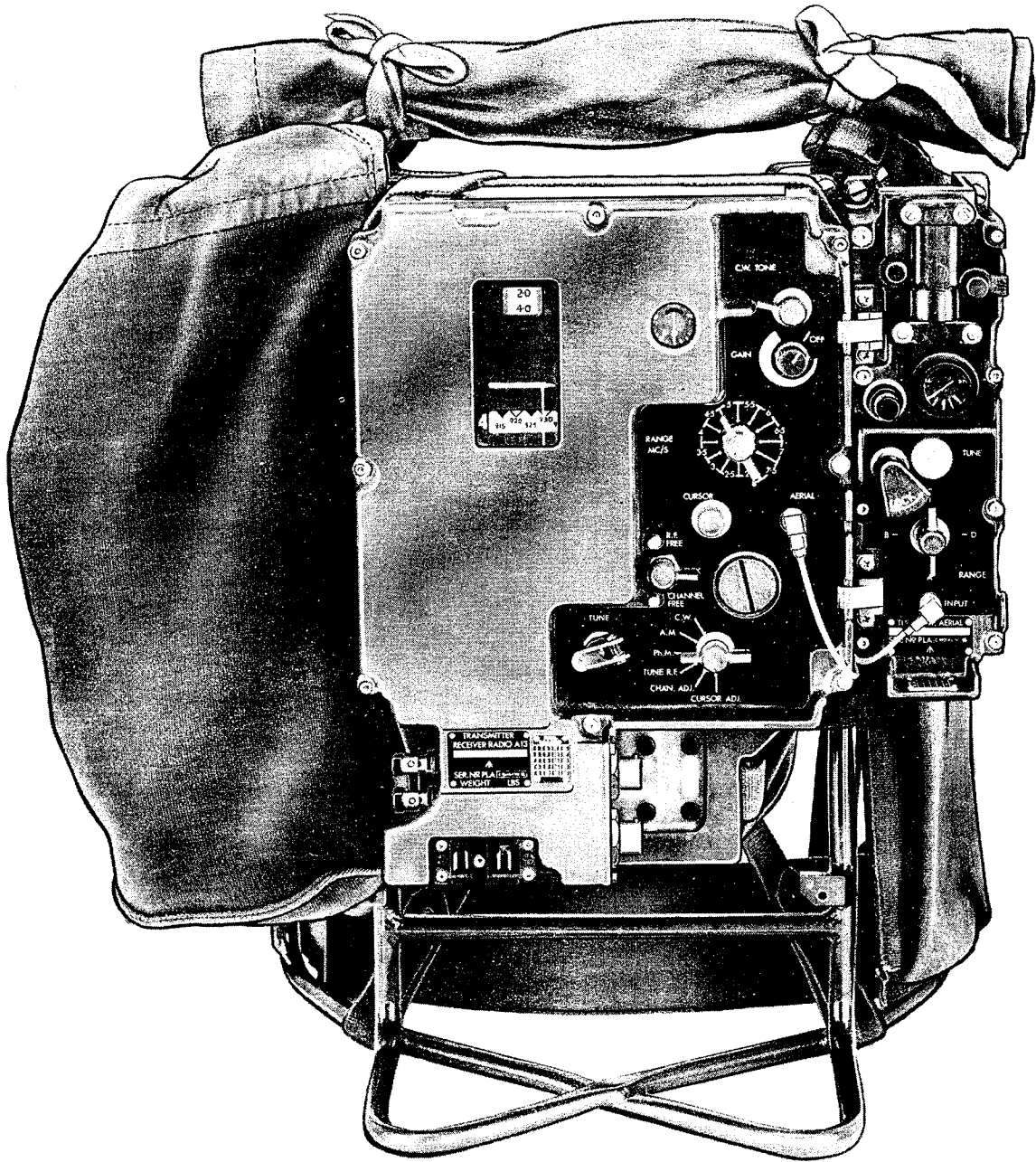

FIG. 1 TR A13

# CHAPTER I

## GENERAL DESCRIPTION

### Section 1 FACILITIES

(1) Purpose

Station radio A13 low power and station radio A13 high power are lightweight manpack radio sets intended primarily for use by infantry at battalion headquarters level and further forward. These sets are immersion proof and suitable for operation and storage in all parts of the world.

(2) Manpack loads

TR A13 is the basic unit in a number of alternative HF radio stations, known collectively as station radio A13. The simplest station is a low power manpack station, carried and operated on one man, but also usable as a ground station. Fig. 1 shows the TR A13 on its carrying frame. By adding to this station an RF amplifier, which increases the transmitted power, it can be converted into a high power manpack station. This also can be carried by one man. It can be operated by one man, either as a manpack or as a ground station. When other ancillary items are added, high power portable stations, carried by two or three men (dependent upon the amount of equipment to be carried) are formed. These are primarily ground stations but all the components of low power or high power manpack stations are contained in them.

(3) Vehicle installations

SR A13 LP or HP manpack stations can be installed in various types of vehicle.

(4) Mode of operation

Voice or CW operation (up to 25 words per minute) are available on HP and LP stations, with a choice of amplitude modulation or phase modulation.

(5) Operating range

The LP manpack station has an 8-ft. whip antenna and its ground wave range using phase modulation may be about six miles by day. The HP manpack station with an 8-ft. whip antenna using phase modulation may give a ground wave range of about twelve miles by day. These ranges can be increased by the use of a 26-ft. vertical antenna. Both LP and HP stations in their ground station role can be operated on

skywaves using long wire antennas. Details of antennas are given on pages 39 to 43.

(6) Two different RF amplifiers

Two different RF amplifiers are available for use in SR A13 HP stations, Amplifier RF No. 12 Mk. 1 and Amplifier RF No. 12 Mk. 2. The Mk. 1 is a valve amplifier, the Mk. 2 is a transistorised amplifier, smaller and of approximately half the weight. The performance of the two amplifiers is similar although the power requirements differ slightly. See page 11. For manpack operations they are completely interchangeable and one can be substituted for the other. Fitting and operating instructions for both amplifiers are included in this handbook.

(7) Frequency range

The frequency range of LP and HP stations is between 2 and 8 Mc/s. Accurate tuning over the range is provided by crystal calibrator check points at 100 kc/s and 10 kc/s intervals. Frequency stability is such that the station will operate satisfactorily for at least one hour before recalibration is required.

(8) Sealed case

TR A13, tuner RF and both amplifiers RF have sealed cases which must not be opened except in workshops.

Section 2 KITS IN WHICH SR A13 IS SUPPLIED

SR A13 equipment is issued under four Complete Equipment Schedules. Paragraphs 1 to 4 below show Army Code Numbers of Service Edition CES and list the various kits supplied to each CES. Certain items are issued separately from the CES stations against an agreed unit scale as not all stations need these additional items. See paragraphs 5 to 8 on page 3. Lists on pages 5 to 9 show how the equipment is re-arranged into manpack loads for operation.

(1) CES 43205 (SR A13 LP basic)

Station kit radio No. 1, TR A13 (5820-99-949-6797) Qty. 1  
See page 5.

Station kit radio No. 2, Antenna and remote ancillaries (5820-99-949-6798)  
Qty. 1 See pages 5 and 9.

Station kit radio No. 3, Voltage regulator (5820-99-949-6799) Qty. 1  
See page 1.

Station kit radio No. 5, Ancillaries (5820-99-102-4389) Qty. 1  
See page 5.

Mast, sectionalised fibreglass, 18 ft. (5985-99-949-6534) Qty. 1  
See page 9.

Battery secondary alkaline, 12V 2 Ah (Z9/6140-99-949-6145) Qty. 4

(2) CES 43206 (SR A13 HP basic)

This CES covers six kits in paragraph 1, plus the following:  
Station kit radio No. 4, Amplifier RF No. 12 Mk. 1. (5820-99-949-6800)

OR

Station kit radio No. 8, Amplifier RF No. 12 Mk. 2. (5820-99-105-4019)  
See page 7.

Carrying frame electrical equipment manpack A13. (5820-99-101-9311)

Cover transmitter receiver canvas, 16 x 30. (5820-99-949-8945)(sunblind)

Station kit radio No. 3, voltage regulator - Qty. 1 (additional)  
Batteries - Qty. 4 (additional).

(3) CES 43207 (SR A13 HP for 'B' vehicles)

This CES covers the six kits in (1) above plus the five kits/items in (2) above, plus the following:

Station kit radio No. 11, TR A13 vehicle conversion (5820-99-105-4020)  
See page 55.

Installation kit electronic equipment A13 in 'B' vehicles. See page 56.

Installation kit electronic equipt. multi-purpose 24V. (5820-99-949-2810)  
See page 57.

(4) CES 43208 (SR A13 HP for FV 432)

This CES covers the six kits in (1) above, plus the five kits in (2) above, plus the following:

Station kit radio No. 11, TR A13 vehicle conversion (5820-99-105-4020)

Installation kit electronic equipment A13 in FV 432 (5820-99-104-3997)

Installation kit electronic equipt. multi-purpose 24V. (5820-99-949-2810)

(5) Frame carrying A13 and canvas sun blind

One frame and one sun blind are included in the SR A13 station (CES 43205) and two frames and two sun blinds in each of CES 43206, 43207 and 43208. In addition a certain number are issued on unit scale for use where it is required to carry the A13 LP station as a two-man pack

(6) Station kit radio No. 6, hand generator See page 7.

(7) Remote control unit See page 9.

(8) Clip-on kit See page 72.

Installation kit electronic equipment SR A13 in Rover Mk. 8 and 9 (5820-99-103-7601) See page 73.

Installation kit electronic equipment SR A13 in Rover Mk. 8 and 9 car~~o~~ (5820-99-103-9317) See page 76.

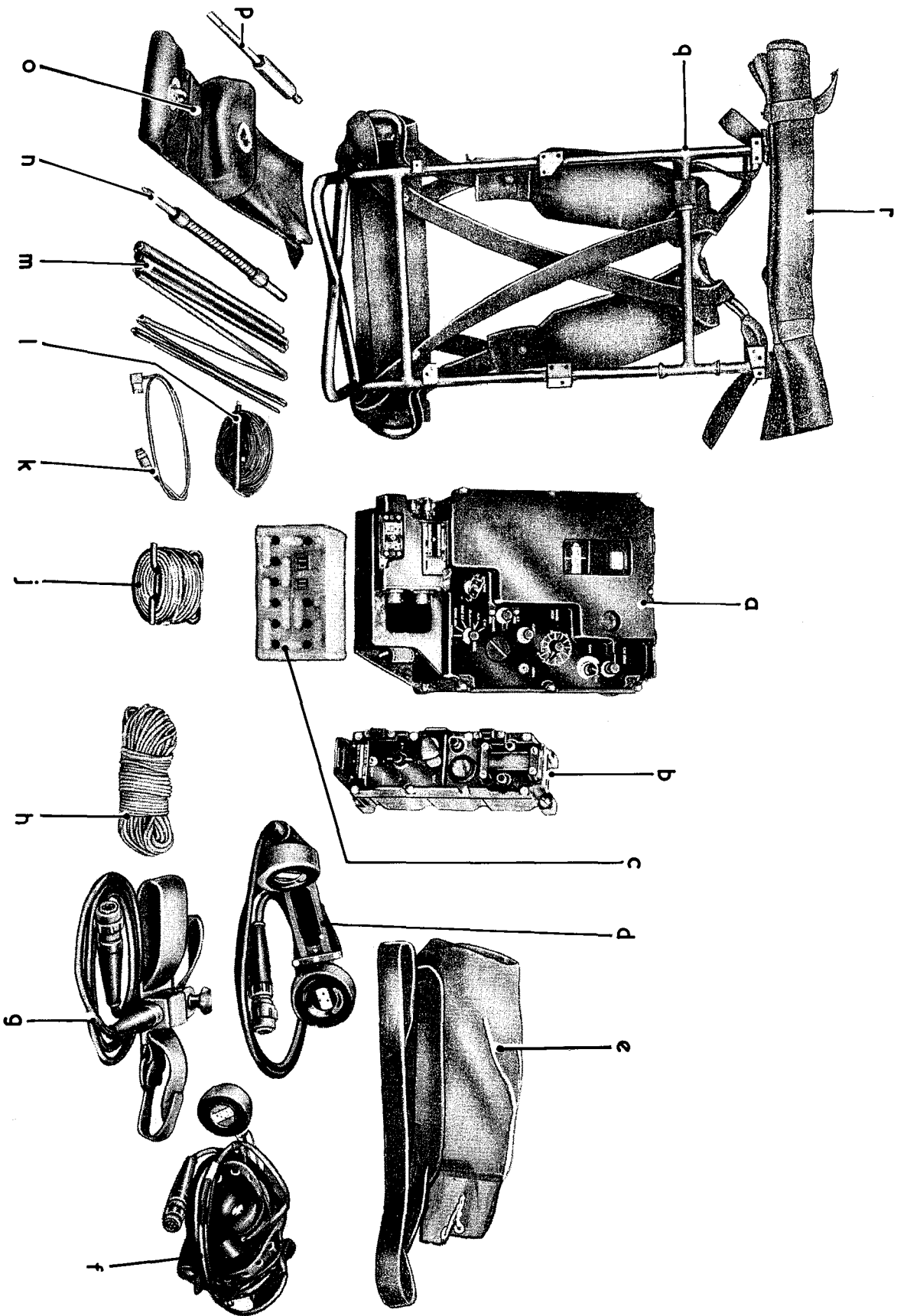

FIG. 2 ITEMS FORMING MANPACK No. 1



### Section 3 COMPOSITION OF MANPACK NO. 1

All the essential equipment to form the LP station is carried on manpack No. 1. It is listed below and illustrated in fig. 2. Letter references below correspond with the annotations in fig. 2. Assembly instructions are given in chapter 2.

#### Supplied in kit No. 1

- (a) Transmitter-receiver radio A13 (5820-99-949-6353) (TR A13)
- (b) Tuner RF antenna A13 (5820-99-949-6154)
- (k) Cable assembly RF, 2-ft. (5995-99-949-6770) (TR A13 to tuner)

#### Supplied in kit No. 5

- (d) Handset SI type (5965-99-949-8135) (two per kit)
- (e) Bag cotton duck, 10 $\frac{1}{2}$ -in. x 6-in. dia. (8105-99-949-6530)  
Stowage of items (d), (f), (g), (h), (j), (k) and (l).
- (f) Headset microphone SI type (5965-99-949-8136) (two per kit)  
Twin headphones with boom microphone.
- (g) Key telegraph (5805-99-949-9618) (morse key)
- (h) Cord antenna erection, 80-ft. (5820-99-949-6925)
- (j) Antenna and frame assembly (5820-99-101-9312) (150-ft braid antenna)
- (l) Antenna counterpoise, 30-ft. (5820-99-949-6861)
- (m) Antenna whip type (5820-99-104-1523) (8-ft antenna)
- (n) Adapter antenna to antenna base, 11.3/4-in. (5820-99-102-0575)
- (o) Case antenna cotton duck, 15 $\frac{1}{2}$ -in x 3 $\frac{1}{2}$ -in. (5820-99-949-6873)  
Stowage of items (m), (n) and (p).
- (p) Spike supporting antenna, 8-in. x 19/32-in. (5820-99-949-6876)
- (q) Carrying frame.
- (r) Cover canvas (sun blind).  
User handbook.

#### Supplied separately

- (c) Battery.

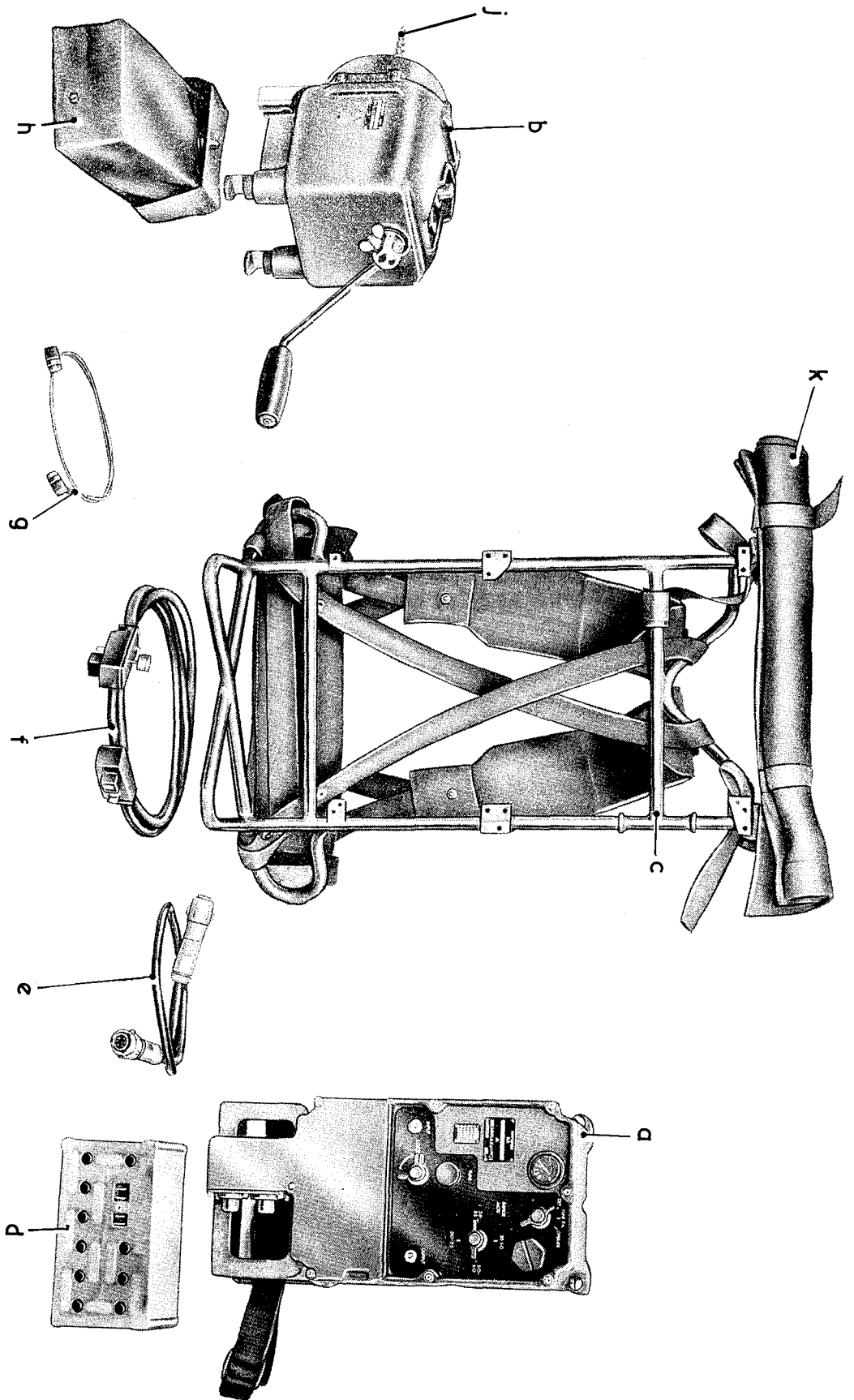

FIG. 3 ITEMS FORMING MANPACK NO. 2

#### Section 4 COMPOSITION OF MANPACK NO. 2

In the LP station the hand generator is carried on manpack No. 2. In the two-man HP station the RF amplifier and the hand generator are both carried on manpack No. 2. Letter references below refer to fig. 3. Assembly instructions are given on pages 22 and 23.

NOTE: Use kit No. 4 for Mk.1 amplifier or kit No. 8 for Mk.2 amplifier

##### Supplied in kit No. 4

- (a) Amplifier RF No. 12 Mk. 1 (5820-99-949-6158)
- (e) Cable assy. 6-condr. 2-ft. 2-in. (5995-99-949-6860) (amplifier to A13)
- (g) Cable assy. RF, 2-ft. (5995-99-949-6770) (amplifier to A13)
- (h) Bag cotton duck  $3\frac{1}{2}$  x 2 x 9 (5820-99-949-6531) stowage of (e) and (g)

##### Supplied in kit No. 8

- Amplifier RF No. 12 Mk. 2 (5820-99-105-3158) (shown in fig. 10)
- (e) Cable assy. 6-condr. 2-ft. 2-in. (5995-99-949-6860) (amplifier to A13)
- (g) Cable assy. RF, 2-ft. (5995-99-949-6770) (amplifier to A13)
- (h) Bag cotton duck  $3\frac{1}{2}$  x 2 x 9 (5820-99-949-6531) stowage of (e) and (g)

##### Supplied in kit No. 6

- (b) Generator d.c. (6115-99-949-8134)
- (f) Cable assembly 2-condr. 6-ft. (5995-99-949-6859)
- (j) Screw mounting generator (5820-99-102-0576)

##### Supplied separately

- (c) Carrying frame
- (d) Battery
- (k) Cover canvas (sun blind)

#### Section 5 COMPOSITION OF ONE-MAN HIGH POWER MANPACK

When a one-man HP manpack station is required, the Mk. 1 amplifier from kit No. 4 above, or the Mk. 2 amplifier from kit No. 8 above, can be added to manpack No. 1 as shown on page 5 and in fig. 2. The HP one-man manpack station is described on pages 18 to 21.

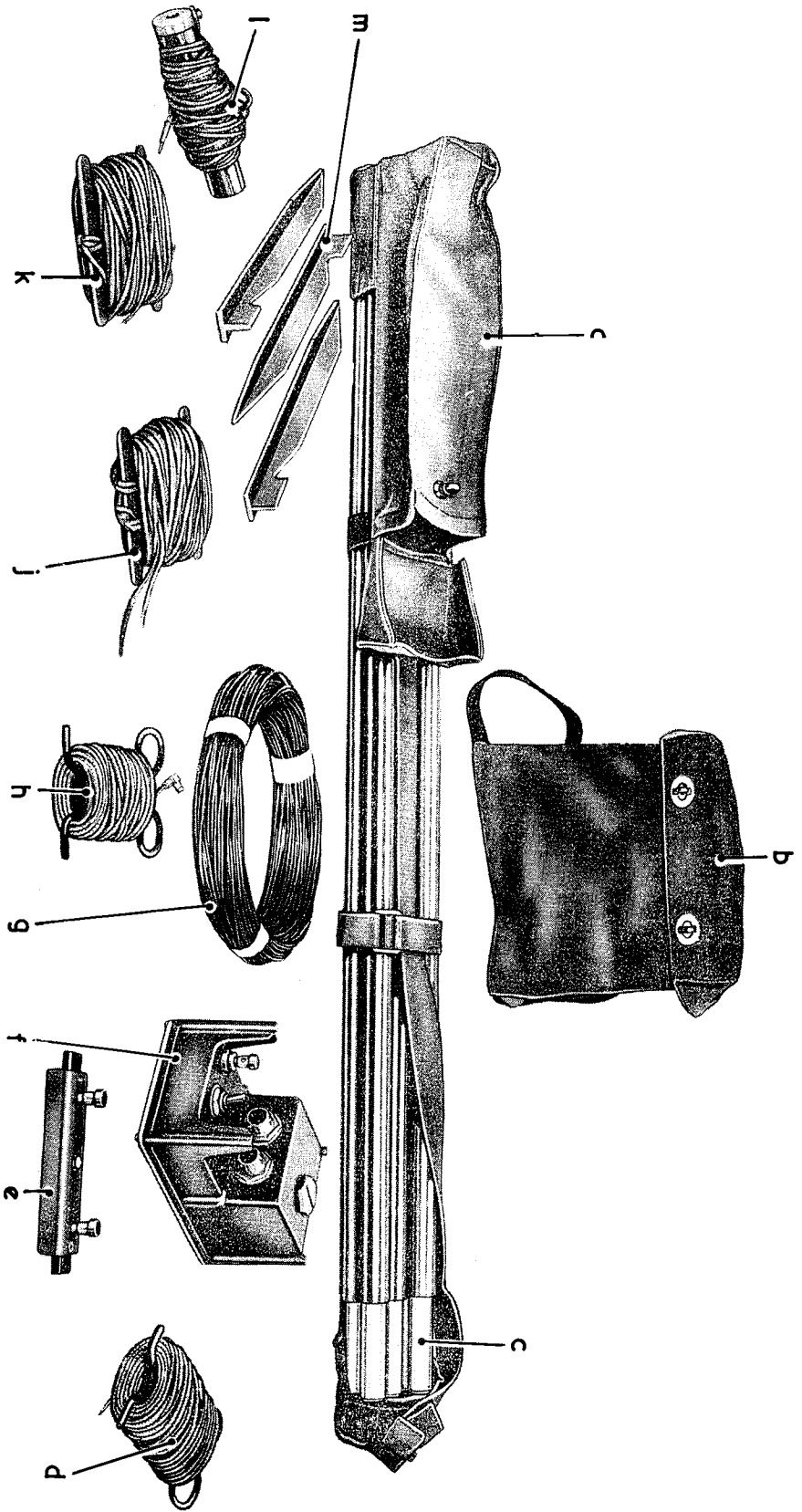

FIG. 4 ITEMS FORMING THIRD MAN LOAD

Section 6 COMPOSITION OF THIRD MAN-LOAD

This load contains antenna gear additional to that in manpack No. 1, and remote control items, to extend the range and facilities of the station. Letter references refer to fig. 4.

Supplied in kit No. 2

- (b) Bag cotton duck, 8.1/4 x 4.3/4 x 8.3/4-in. (8105-99-949-6821)  
For stowage of items (d), (e), (f), (g) and (h).
- (d) Antenna and frame assembly (5820-99-101-9312)  
150-ft, braid antenna. One is supplied in kit No. 2.  
When a second 150-ft. braid antenna is required to make a dipole, use the other one supplied in kit No. 5.
- (e) Board antenna junction plastic, 5.1/16 x 1 x 11/16 (5820-99-949-6883)  
Dipole centre junction, fitted between two braid antennas and the 50-ft. coaxial cable.
- (h) Cable assembly RF, 50-ft. (5820-99-101-9805)  
Dipole centre junction to TR A13 or RF amplifier.  
Supplied on reel 4.7/8-in. x 4.3/4-in.

Supplied in mast kit

- (a) Case mast cotton duck, 3-ft. 3.1/4-in. x 3 x 5.1/4 (5985-99-949-6892)  
For stowage of items (c), (j), (k), (l) and (m).
- (c) Mast sections fibreglass, 3-ft. 3-in. x 1-in. o.d. (5985-99-949-6851)  
Six sections provided.
- (j,k) Guys Terylene rope, guy plate (5975-99-949-6853) (two per kit)  
Each guy plate has three 25-ft. guy ropes and fits onto the mast.
- (l) Adapter mast fibreglass, 1-in. x 4.15/16-in. (5985-99-949-6898)  
To fit the whip antenna to the top of the mast.
- (m) Pins tent al., 12 x 1 x 1-in. (8340-99-949-6882)  
Three per kit.

Supplied separately

- (f) Control transmitter-receiver remote (5820-99-949-6365)
- (g) Cable telephone (6145-99-901-0199)  
100-ft. coil of D10 remote control cable.

Section 7 SPARE BATTERY PACKS

A spare battery pack as illustrated in fig. 5 is carried on a scale of one per LP station or two per HP station. It contains the following items.

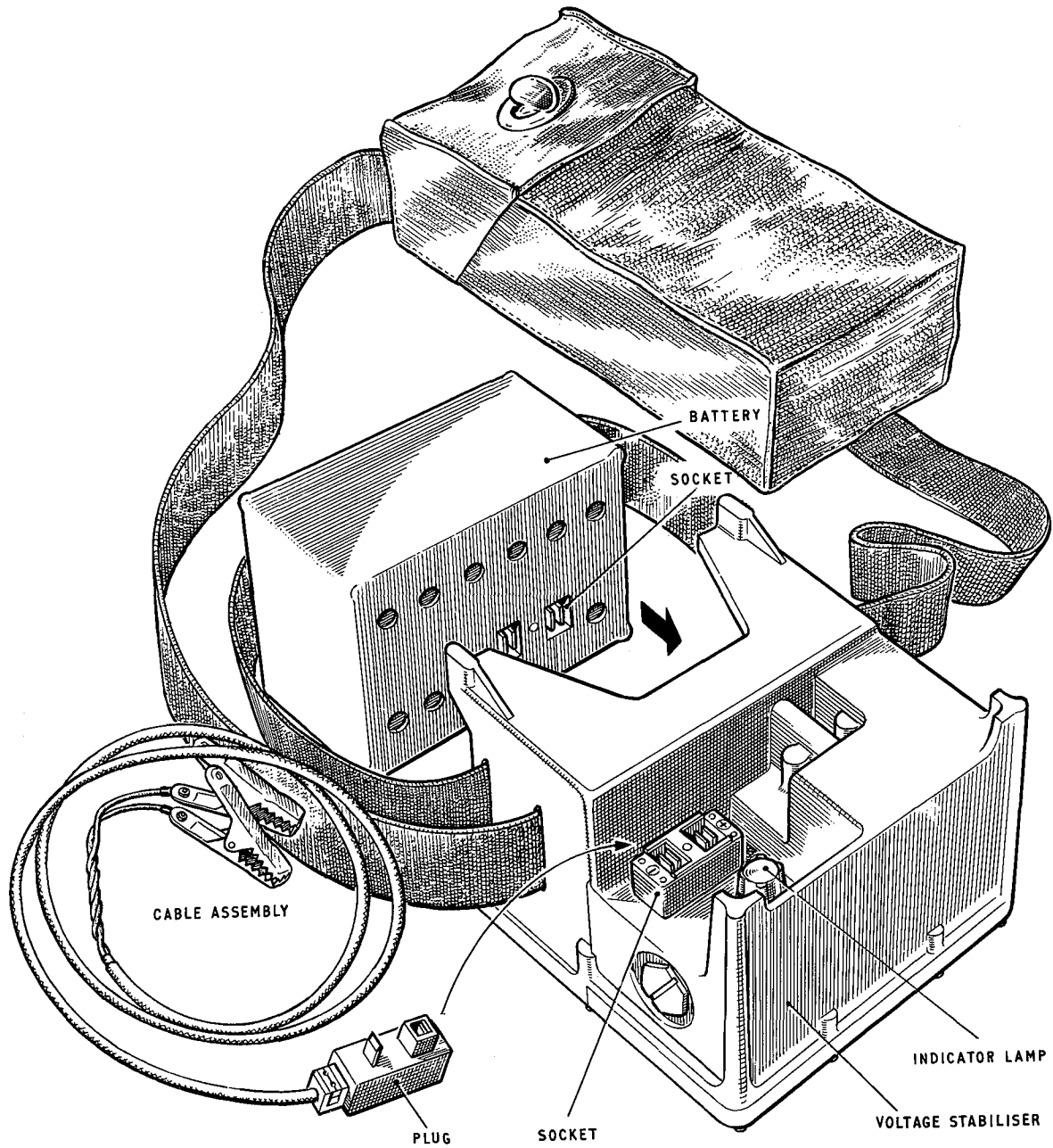

**FIG. 5 STABILISER AND SPARE BATTERY PACK**

Supplied in Kit No. 3

Stabiliser voltage, transistorised, A13 (5820-99-949-6111)  
Cable assy. 2-condr. 6-ft. (5995-99-949-7148) (Stabiliser to 24V d.c.)

Supplied separately

Battery  
Carrying strap and pouch.

The spare battery is normally carried in the stabiliser. During transportation and charging it must be pushed firmly into its housing where it is secured by looping the strap through the slits and fastening the quick release buckle. See fig. 5. The strap acts as a sling for the stabiliser and the pouch and also secures the battery. The cable is stowed in the pouch when not in use.

Section 8 POWER SUPPLY

(1) 12V batteries

Batteries secondary alkaline 12V 2Ah used with SR A13 are sealed and unspillable. Identical batteries are fitted in TR A13 and in the RF amplifier.

(2) Battery life

The length of life of the battery, before it needs re-charging, will vary according to how it is used. The following estimates all assume a transmit/receive ratio of 1/9.

(a) SR A13 LP

TR A13 operates on a 12V battery. The life of the battery, between charges, is approximately eight hours.

(b) SR A13 HP with Mk 1 amplifier

The Mk 1 amplifier requires a 12V d.c. supply for operating. It is fitted with a 12V battery of the same type as that in the TR A13. Batteries in TR A13 and Mk 1 amplifier are connected in parallel by means of an internal connection. They should last for six hours before needing recharging.

(c) SR A13 HP with Mk 2 amplifier

The Mk 2 amplifier is also fitted with a 12V battery of the same type although it actually requires 24V d.c. for operation.

Batteries in TR A13 and Mk 2 amplifier are connected internally so that they are in parallel on 'receive' but in series to give 24V to the amplifier on 'transmit'. These batteries should last approximately eight hours before needing recharging.

(3) Current consumption

SR A13 LP

Receive	180 milli-amps
Low power transmit	725 milli-amps

SR A13 HP with Mk. 1 amplifier

High power transmit 5.3 amps

SR A13 HP with Mk. 2 amplifier

High power transmit (24V)	1.6 amps amplifier battery
	2.3 amps TR A13 battery

(4) Battery charging

Provision is made for the batteries to be charged direct from a hand generator or by means of a stabiliser from a 24 volt d.c. supply. See pages 47 to 52.

(5) Using external 12V batteries

Instead of the internal battery or batteries, SR A13 LP or HP can be operated on 12V vehicle batteries. See page 45 for details.

(6) Using the harness adapter

(a) SR A13 HP with Mk. 1 amplifier

When TR A13 and RF amplifier are used on the harness adapter the internal batteries are removed and a 12V d.c. supply is obtained via the harness adapter from the 24V vehicle power supply source.

(b) SR A13 HP with Mk. 2 amplifier

In addition to (a) above the 24V d.c. supply required by the Mk. 2 amplifier on 'transmit' is obtained by a direct connection to the harness adapter.

Section 9 AUDIO FACILITIES

(1) Operating SR A13 direct

Two parallel audio sockets are provided on TR A13, one for the headset and one for the handset, or alternatively, the morse key. See fig. 15. A combined on-off switch and gain control is fitted on TR A13. This adjusts the volume in the headphones or handset. The headset pressel switch is built into a small junction box incorporated in the headset connector. The handset has a hand-grip pressel switch.



(2) Operating SR A13 through the harness adapter

When SR A13 is installed in a vehicle with the harness adapter, it can be operated through a junction box J1 and control harness type 'B' equipment. Control harness units are described in Part 4 of the user handbook provided with the multi-purpose installation kit.

Section 10 WEIGHTS AND DIMENSIONS

Item	Width in.	Height in.	Depth in.	Weight
Amplifier RF No. 12 Mk. 1 (excluding battery)	6	12 $\frac{1}{4}$	6	9 lb. 10 oz.
Amplifier RF No. 12 Mk. 2 (excluding battery)	9 $\frac{1}{2}$	6	5	5 lb.
Antenna whip				5 oz.
Battery (each)	5 $\frac{1}{4}$	3	3 $\frac{3}{4}$	3 lb. 14 oz.
Braid antenna on Frame				1 lb. 8 oz.
Carrying frame	15	19	8 $\frac{1}{2}$	4 lb. 4 oz.
Dipole centre junction				3 oz.
Earth spike and counterpoise		8		8 oz.
Hand Generator	7 $\frac{3}{4}$	5 $\frac{3}{4}$	5 $\frac{3}{4}$	11 lb. 6 oz.
Handset				12 oz.
Harness adapter	26 $\frac{1}{2}$	13	10 $\frac{1}{2}$	30 lb.
Headgear				1 lb. 4 oz.
Key				9 oz.
Mast in carrying case		39		7 lb. 8 oz.
Remote control unit	3 $\frac{3}{4}$	6 $\frac{1}{2}$	3	1 lb. 15 oz.
Stabiliser	6	7 $\frac{1}{4}$	4	2 lb. 13 oz.
Stabiliser bracket	8 $\frac{3}{4}$	7	4 $\frac{1}{4}$	2 lb.
TR A13 (excluding battery)	8 $\frac{3}{4}$	12 $\frac{1}{4}$	6	16 lb. 12 oz.
Tuner RF	3	9	5 $\frac{3}{4}$	4 lb. 1 oz.

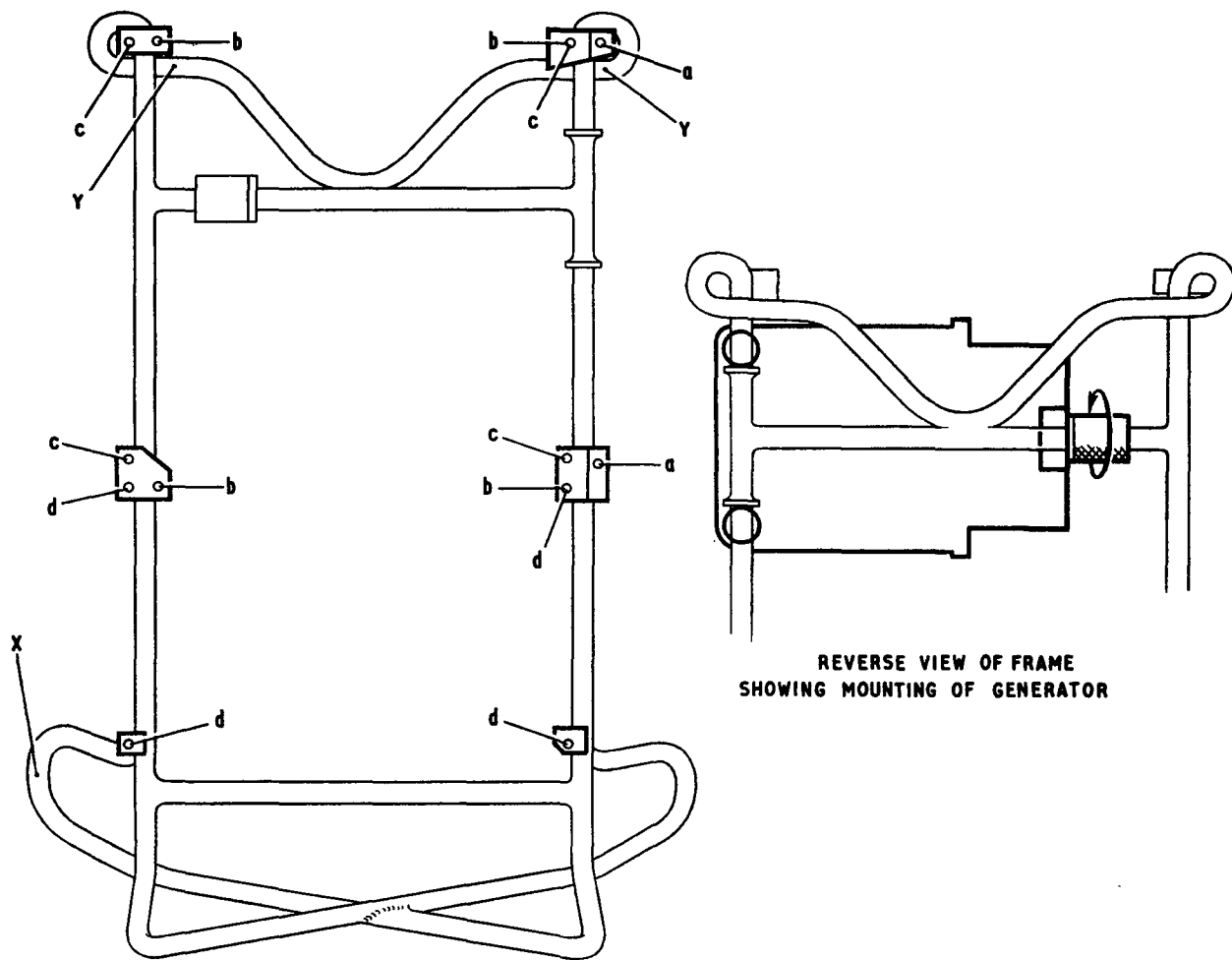

MANPACK FRAME

REVERSE VIEW OF FRAME  
SHOWING MOUNTING OF GENERATOR

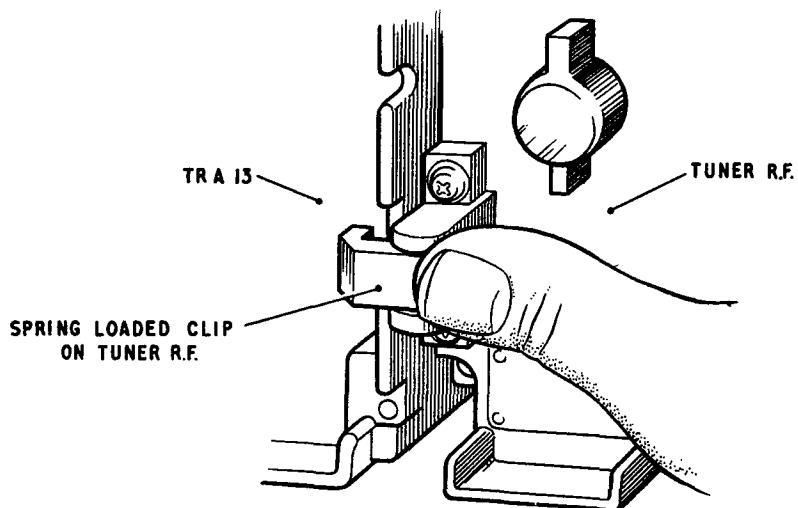

FIG. 6 METHOD OF ATTACHMENT TO THE MANPACK FRAME

## CHAPTER 2

# OPERATION

Instructions for assembling SR A13 LP and HP manpack and ground stations for different roles are given in the following sections.

### Section 11 LP MANPACK STATION

#### (1) Assembly instructions

##### (a) TR A13

To fit the equipment, place the carrying frame down upon its back. Fit the TR A13 in an upright position on the frame so that the four spring loaded captive screws are located above the holes marked 'b' in fig. 6. There is a locating pin and hole near the upper right hand screw to assist in location. Screw the TR A13 to the frame. The earth spike can be used as a screwdriver. Fig. 7 shows the complete assembly.

##### (b) Ancillaries pouch

If they are not to be used at once, stow the headset, handset, key, cord antenna erection, antenna counterpoise and braid antenna. Tie the pouch to the frame on the left hand side of TR A13. Fasten the buckle under TR A13.

##### (c) Tuner RF

Fit the tuner RF by placing the spring loaded clips over the recesses in the TR A13 case and tighten its two spring loaded captive screws into holes 'a' in fig. 6. Connect the INPUT socket on the tuner RF to the AERIAL socket on the TR A13 by means of the 2-ft. coaxial cable.

##### (d) Antenna pouch

In this pouch stow the whip antenna, adapter and spike. Tie the pouch to the right hand side of the frame by means of its tapes.

##### (e) Sun blind

Tie the sun blind to the top of the carrying frame by means of the two tapes. Roll it and tie it as in fig. 7.

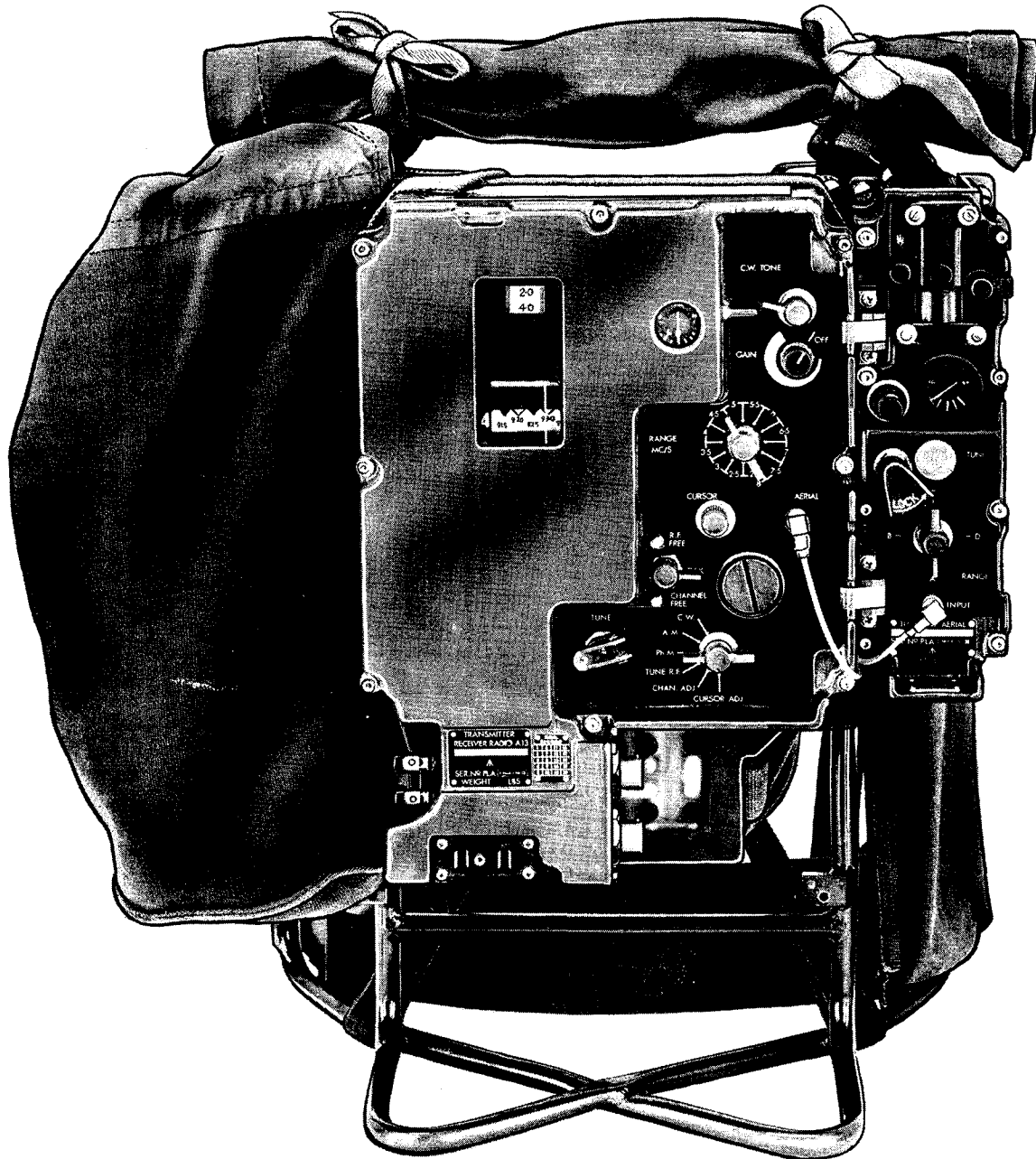

**FIG. 7 LOW POWER MANPACK STATION**

(2) Preparing for operation

(a) Battery

Ensure that a charged battery is in position in TR A13 and that the retaining strap is correctly fitted and adjusted. Fig. 8 shows the strap on the Mk. 2 amplifier.

(b) Adjusting the carrying frame

Fit the main webbing supporting straps over the operator's shoulders. Adjust them so that the manpack rests comfortably on his back and fasten the waist belt.

(c) Antenna

Extend the whip antenna to its full length by plugging the sections together. Insert the antenna adapter into the tuner RF and fit the whip antenna into the top of the adapter. See fig. 13.

(d) Headgear

Position and adjust the headgear to suit the operator's requirements. Loop the cable from the headset under his left arm pit and plug it into the upper 6-way socket on TR A13. The pressel switch junction box should hang free on his chest. A second person can speak and listen on the radio if a handset is plugged into the lower 6-way socket.

(e) Tuning

The LP station is now ready for tuning. See page 29.

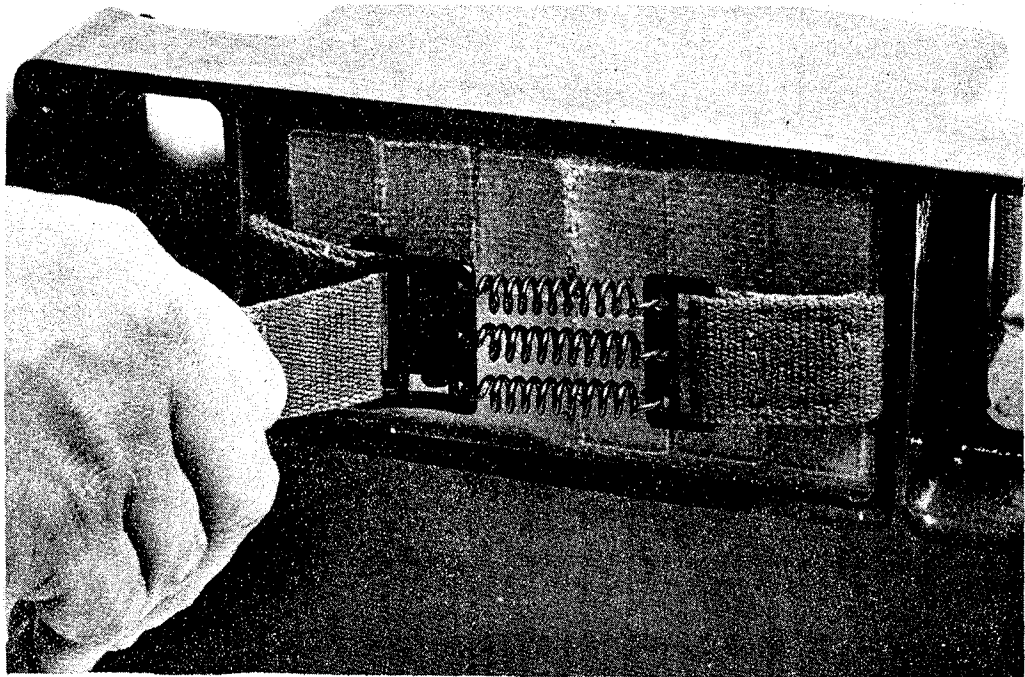

FIG. 8 BATTERY STRAP ASSEMBLY

Section 12 HP MANPACK STATION WITH MK.1 AMPLIFIER

(1) Assembly instructions

(a) TR A13

Fig. 6 shows the frame and fig. 9 the HP manpack assembly with the Mk. 1 amplifier. Place the frame on its back. Position the TR A13 so that the securing screws are located in holes 'C' fig. 6. There is a locating pin and hole near the lower right hand screw to assist in location. Tighten the four captive screws. The earth spike can be used as a screwdriver.

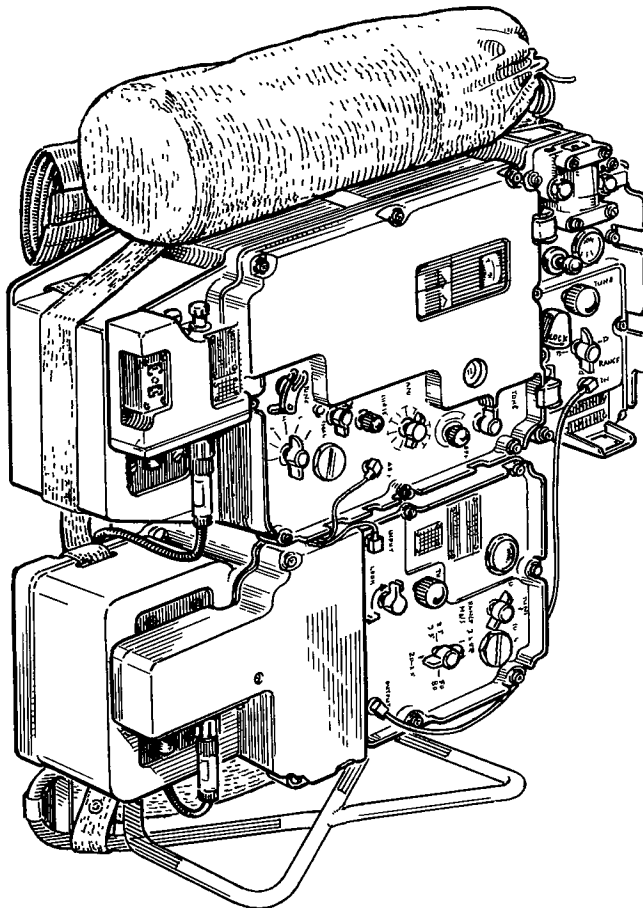

**FIG. 9 HIGH POWER MANPACK STATION WITH Mk.I AMPLIFIER**

(b) Ancillaries pouch

Fit the ancillaries pouch so that it now lies at the top of the frame with the fixing strap around the TR A13. See fig. 9.

(c) Tuner RF

Fit the tuner RF by locating the spring clamps over the recesses on the TR A13 with the fixing screws again being screwed into holes 'a' fig. 6.

(d) RF amplifier

Position the RF amplifier across the frame with its captive screws located in holes 'd' fig. 6. There is a locating pin and hole near the lower righthand screw to assist in location. Tighten the screws.

(e) Connections

Fit the 2-ft. 2-in. cable between the upper 6-way socket on TR A13 and the upper 6-way socket on the RF amplifier. Fit the 2-ft. coaxial cable between the AERIAL socket on the TR A13 and the INPUT socket on the RF amplifier. Fit a similar cable between the OUTPUT socket on the RF amplifier and the INPUT socket on the tuner RF.

(f) Antenna pouch

In this pouch store the whip antenna, adapter and spike. Tie the pouch to the right hand side of the frame.

(g) Sun blind

Tie the sunblind to the top of the frame as in the LP manpack station.

(2) Preparing for operation

(a) Batteries

Ensure that charged batteries are in position in both the TR A13 and the RF amplifier. See page 29.

(b) Antenna

If it is to be used, plug the antenna adapter into the tuner RF. Assemble the 8-ft. whip antenna and plug it into the tuner RF or into the adapter.

(c) Headgear

See paragraph (d) on page 17.

(d) Tuning

The station is now ready for tuning. See page 29.

NOTE - If it is required to operate the HP station on LP it is only necessary to switch off the RF amplifier.

Section 13 HP MANPACK STATION WITH MK.2 AMPLIFIER

(1) Assembly instructions

(a) TR A13

To fit the equipment, place the carrying frame down upon its back, position TR A13 so that the controls are towards the bottom of the frame as in fig. 10 and tighten the securing screws.

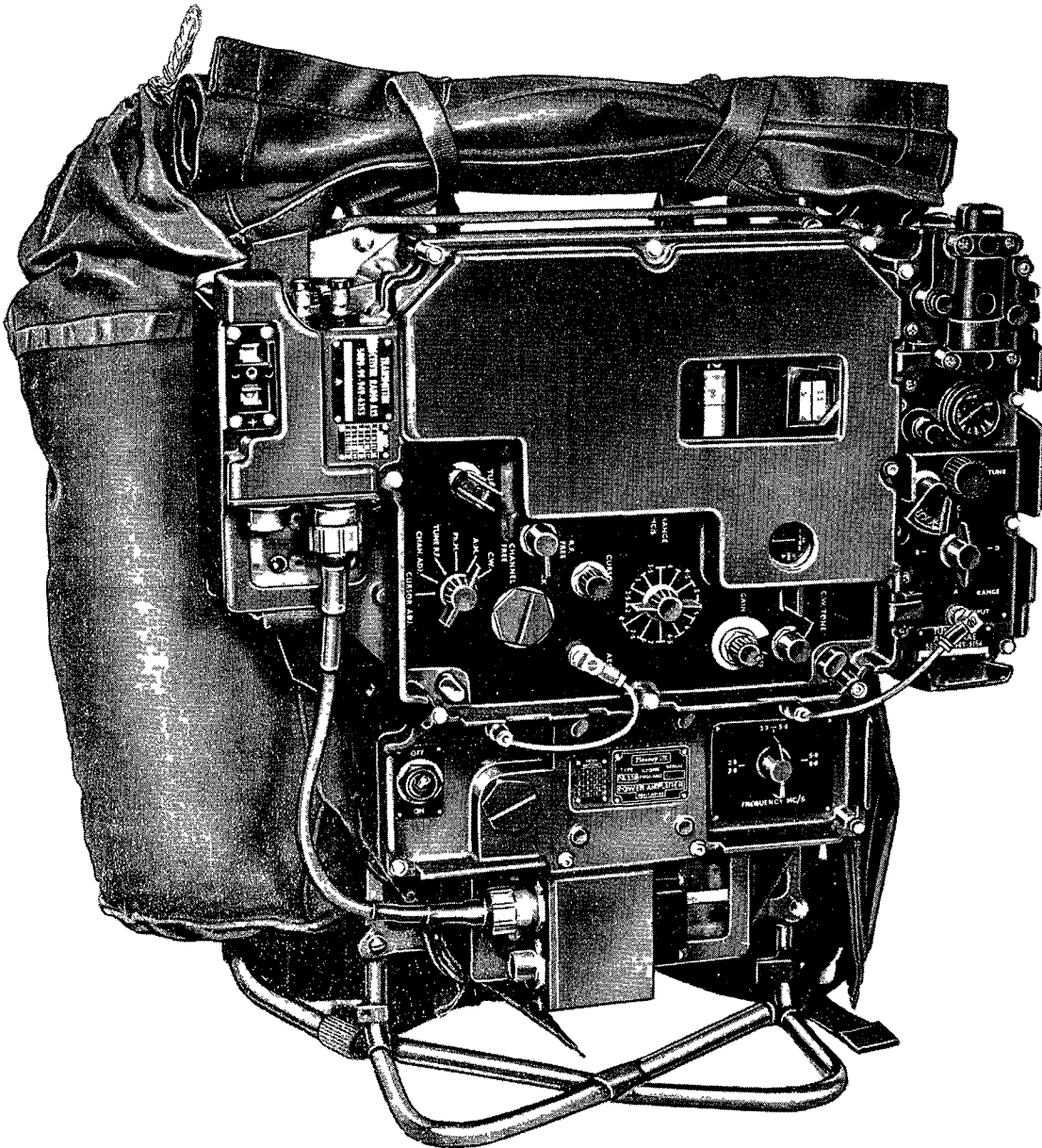

FIG. 10 HIGH POWER MANPACK STATION WITH Mk. 2 AMPLIFIER



### RF amplifier

Position the RF amplifier across the frame with its captive screws located in holes 'd' fig. 6. Tighten the screws. See fig. 10.

### Tuner RF

Fit the tuner RF by placing the spring loaded clips over the recesses in the TR A13 case and tighten its two spring loaded captive screws into holes 'a' in fig. 6.

### Connections

Connect the upper 6-way socket on TR A13 to the upper 6-way socket on the RF amplifier with the cable assembly, 6-way, 2 ft. 2-in. long. Connect the coaxial AERIAL socket on TR A13 to the coaxial INPUT socket on the RF amplifier with cable assembly RF, 2-ft. long. Connect the coaxial OUTPUT socket on the RF amplifier to the coaxial INPUT socket on the tuner RF with cable assembly, RF, 2-ft. long.

### Antenna pouch

Tie the antenna pouch to the right hand side of the frame by means of tapes.

### Ancillaries pouch

Tie the ancillaries pouch to the frame on the left hand side of TR A13. Fasten the buckle under the TR A13. See fig. 10.

### Sun blind

Tie the sun blind to the top of the frame as in the LP manpack station.

## paring for operation

### Batteries

Ensure that charged batteries are in position in both TR A13 and the RF amplifier. See page 29.

### Antenna

Plug the antenna adapter into the tuner RF. Assemble the 8-ft. whip antenna and plug it into the adapter.

### Headgear

See paragraph (d) on page 17.

### Tuning

The station is now ready for tuning. See page 29.

Section 14 ASSEMBLY OF MANPACK NO. 2

(1) Hand generator

Slacken the knurled ring nut on the frame top cross-member. Slot the two recessed pillars of the generator over the frame right side member so that they rest either side of the cross-member. Lower the single slotted pillar onto the cross-member and tighten the knurled ring nut into the pillar so that the generator is clamped firmly into the frame. Close the handle of the generator into its stowed position as shown.

(2) RF amplifier (when manpack No. 2 is part of a two-man HP station)

Place the RF amplifier across the frame so that the spring loaded captive screws are located above holes (d) in fig. 6. There is a locating pin and hole near the lower right hand screw to assist in location. Tighten the screws. Fig. 11 shows the Mk. 1 amplifier and fig. 12 the Mk. 2 amplifier.

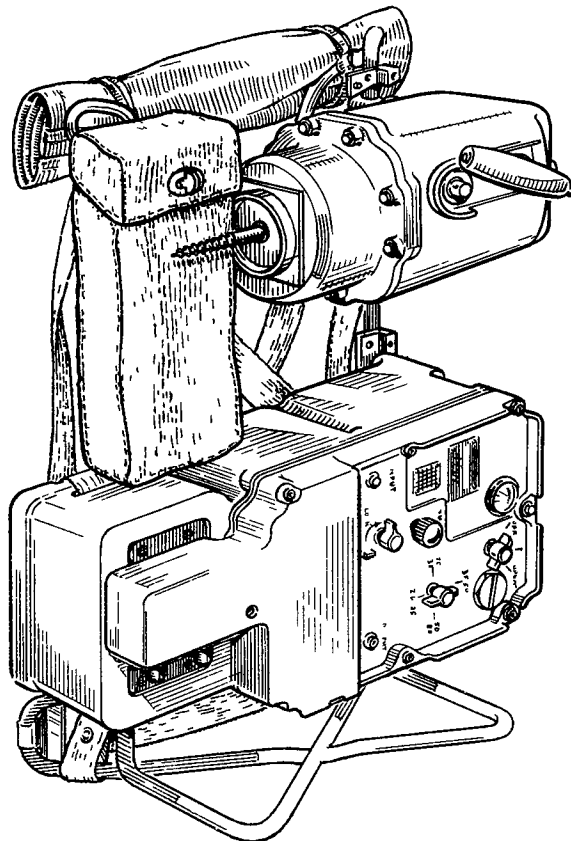

**FIG. 11 MANPACK No. 2 ASSEMBLY WITH Mk. I AMPLIFIER**

- (3) Bag cotton duck, 3 $\frac{1}{2}$  x 2 x 9-in.

Tie this pouch to the top left hand corner of the frame by means of the tapes attached to it. See the illustrations.

- (4) Sun blind

Tie the sun blind to the top of the manpack frame. Roll it and tie it as shown in the illustrations.

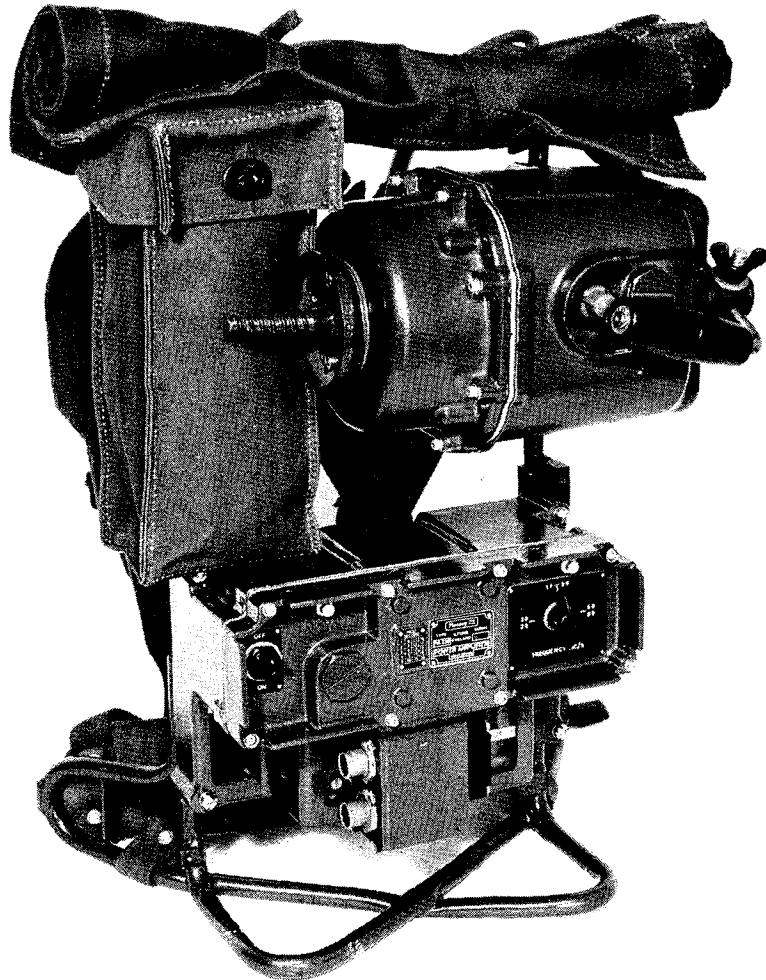

**FIG. 12 MANPACK No. 2 ASSEMBLY WITH Mk. 2 AMPLIFIER**

Section 15 IF GROUND STATION

The station as assembled for manpack use can be operated on the ground.  
See fig. 13.

KEEP THE SUN OFF THE SET  
See paragraph 4



**FIG. 13 LOW POWER GROUND STATION**

(1) Antenna

When using the 8-ft. whip antenna assemble it with the flexible antenna adapter and plug it into the whip socket on the tuner RF. Place the carrying frame either upright as shown in fig. 13, or on its back, but keep the whip antenna vertical by bending the adapter. Alternatively, any of the antennas described on page 39 can be used. The whip antenna and adapter should then be removed and stowed in the antenna pouch.

NOTE - If the dipole antenna is to be used the tuner RF is not required. See page 42. Connect the dipole direct to TR A13 by means of the 50-ft. coaxial cable.

(2) Headgear

(a) For Ph.M. or AM operation

Connect the handset into the lower of the two 6-way sockets on the TR A13.

(b) For CW operation

Connect the morse key to the lower of the two 6-way sockets on the TR A13. Connect the headgear to the upper of the two 6-way sockets on the TR A13.

(3) Tuning

The equipment is now ready for tuning. See page 29.

(4) Keep the sun off the equipment

TR A13 will get warm when it is switched on but the heat will dissipate in the air. If the sun is allowed to shine on the radio set, however, it will raise the temperature of the case and the heat will not dissipate as readily, with the result that the radio set may overheat.

A canvas sun blind is rolled and ried at the top of every SR A13 manpack assembly. When the radio set is operated in direct sunlight, particularly in hot climates, the sun blind should always be unrolled and draped over it.

(5) Float charging the battery

Whenever possible the battery should be float charged when the equipment is being used. A second man can operate the hand generator as shown in fig. 13. Full instructions for operating the hand generator are given on pages 48 and 49.

KEEP THE SUN OFF THE SET

See page 25

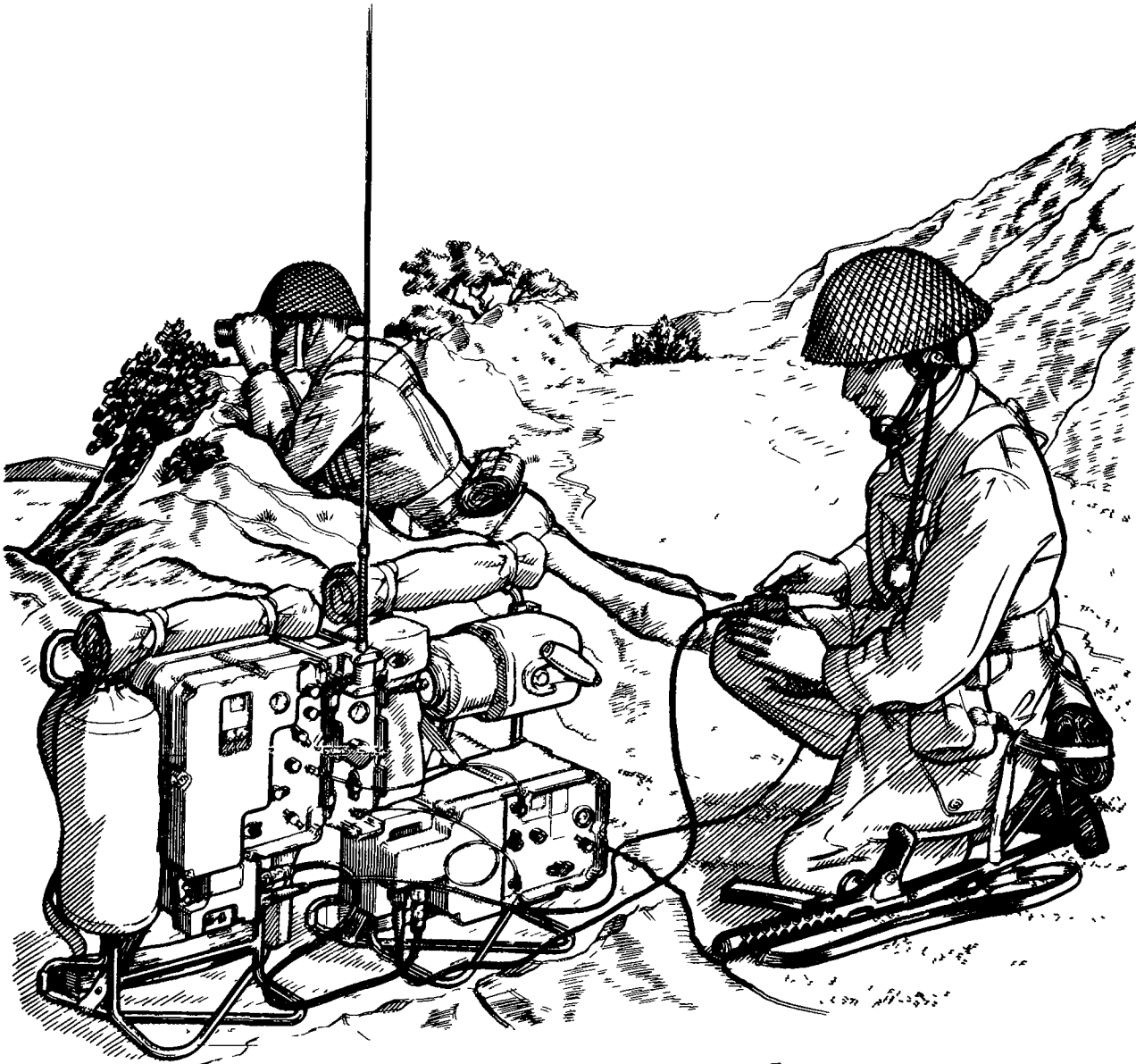

**FIG. 14 HIGH POWER GROUND STATION**

Section 16 HP GROUND STATION

(1) Assembly instructions

- (a) Fig. 14 shows an HP ground station consisting of an LP manpack station and a manpack No. 2. Place the two manpack frames on the ground side by side. Ensure that there are charged batteries in both the TR A13 and the RF amplifier.

- (b) Connect the upper 6-way socket on TR A13 to the upper 6-way socket on the RF amplifier with the 6-way 2-ft. 2-in. cable.
- (c) Connect the TR A13 AERIAL socket to the RF amplifier INPUT socket using the cable assembly RF 2-ft.
- (d) Connect the RF amplifier OUTPUT socket to the tuner RF INPUT socket. Use a cable assembly RF 2-ft. if the tuner RF is on the manpack frame as shown in fig. 14 or 50-ft. if it is set up remotely.

NOTE - If the dipole antenna is to be used the tuner RF is not required. See page 43. Connect the dipole direct to the RF amplifier by means of the 50-ft. coaxial cable.

(2) Antenna

When using the 8-ft. whip antenna assemble it with the flexible antenna adaptor and plug it into the WHIP socket on the tuner RF. Alternatively any of the other antennas described on page 39 can be used.

(3) Headgear

(a) For Ph.M or AM operation

Connect the handset into the lower of the two 6-way sockets on TR A13. Connect the headgear into the lower of the two 6-way sockets on the RF amplifier.

(b) For CW operation

Connect the morse key to the lower of the two 6-way sockets on RF amplifier. Connect the headgear to the lower of the two 6-way sockets on TR A13.

(4) Tuning

The equipment is now ready for tuning. See page 29.

WARNING - When using the HP ground station with the 8-ft. whip antenna at frequencies less than 3 Mc/s, transmission must be limited to 10 minutes in any half hour or the equipment may be damaged.

(5) Operating on low power

If it is required to operate the HP station on LP it is only necessary to switch off the RF amplifier.

IMPORTANT - Do not switch the RF amplifier OFF while transmitting.

(6) Float charging the battery

Whenever possible the batteries should be float charged when the equipment is being used. See fig. 13.

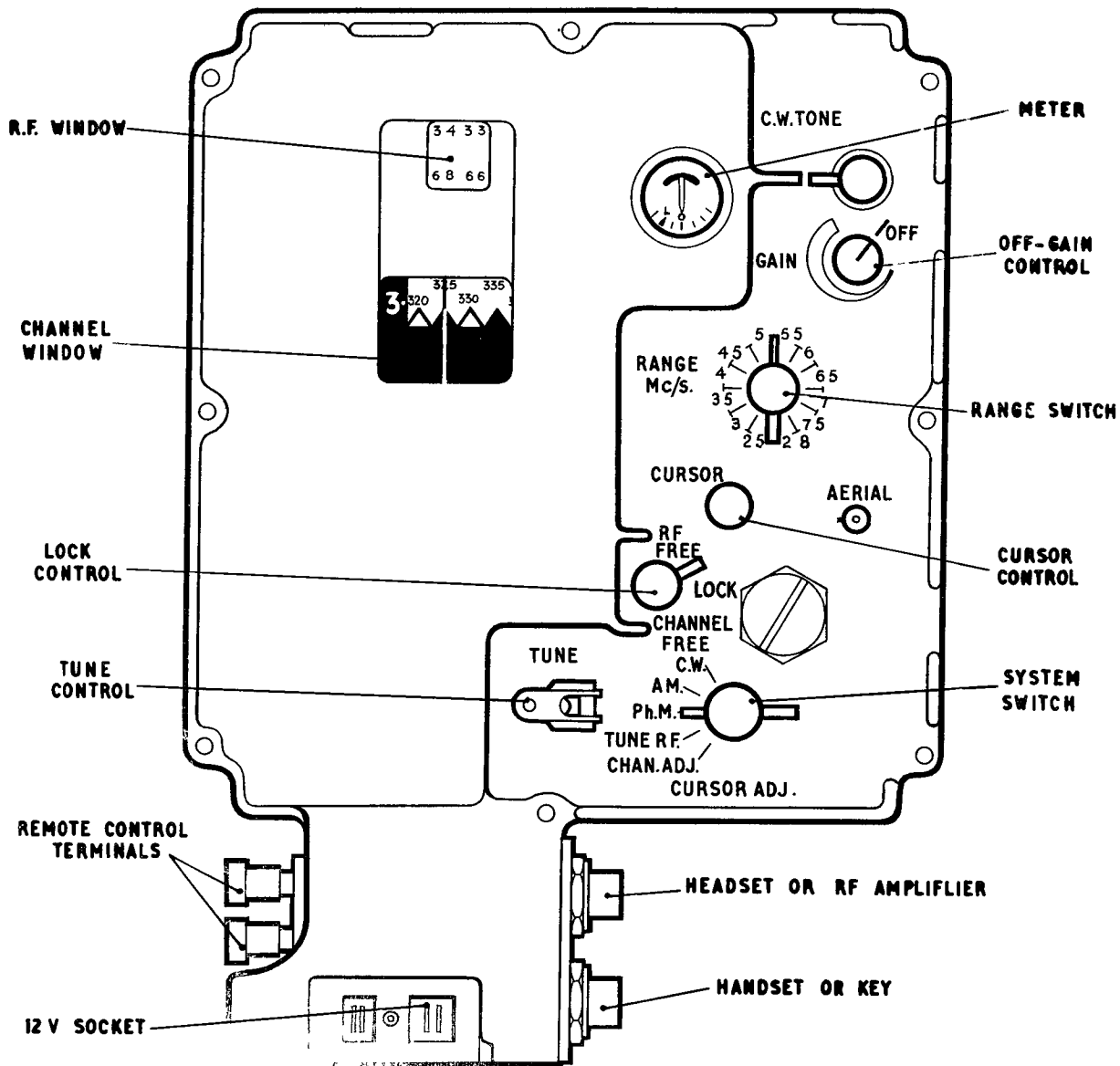

FIG. 15 TR A13 CONTROLS



## Section 17 CHECKING BATTERY VOLTAGE

Before tuning the equipment check the voltage of the battery in TR A13, and in the RF amplifier if this is fitted.

- (1) Turn the TR A13 system switch to Ph ~~M~~, AM or CW. See fig. 15.
- (2) Turn the TR A13 OFF/GAIN control to ON. This combined ON-OFF/GAIN control also adjusts the audio level in the headgear fitted to the TR A13.
- (3) As the TR A13 is switched ON the meter at the top of the panel should indicate approximately '0' or above. If it does not, change the battery or batteries for fully charged replacements. The 'L' mark on the scale indicates a battery voltage of 10 volts, below which the battery should be changed.
- (4) In the HP station the meter indicates the state of charge of both batteries. If the reading is low, change both batteries.
- (5) During operation, especially on transmit, frequently check that the battery voltage indicated on the TR A13 meter has not reached the 'L' position. If the voltage falls to 'L' the battery or batteries should be changed, or float charging should immediately be commenced. See pages 47 and 48.

## Section 18 TUNING TR A13

Fig. 15 indicates the controls on TR A13. Figs. 16A and 16B on pages 30 and 31 show the sequence of tuning.

NOTE - Fig. 16A shows an example when the required frequency is above the mid-point of the megacycle band, for which the frequency 3.8575 Mc/s is chosen. Fig. 16B shows an example when the required frequency is in the lower half of the megacycle band and for this example 3.325 Mc/s is chosen.

- (1) Turn the RANGE switch on TR A13 to the position of the required frequency.
- (2) Move the LOCK control to the RF FREE position.
- (3) Rotate the TUNE control until the figures nearest to the required frequency are shown in the centre of the RF window. In fig. 16A, inset (a), the frequency showing is 3.900 as the required frequency is 3.8575 Mc/s. In fig. 16B inset (a) the frequency showing is 3.300 as the required frequency is 3.325 Mc/s.
- (4) Turn the system switch to the CURSOR ADJ. position.
- (5) Move the LOCK control to the CHANNEL FREE position.

- (6) Rotate the TUNE control until the 100 kc/s point nearest to the required frequency appears in the channel window. Fig. 16 inset (b).
- (7) Ensure that when the TUNE control is rocked over a small amount in either direction, the meter pointer moves in the same direction as the top of the knob and the channel scale. If it does not, vary the TUNE control slightly in either direction until a point is found where it does.
- (8) Adjust the TUNE control until the meter pointer indicates centre-zero.
- (9) Adjust the CURSOR control until the cursor (the perpendicular line across the channel window) coincides with the chosen 100 kc/s point. Fig. 16 inset (c).



(d) SET SCALE TO APPROXIMATE FREQUENCY

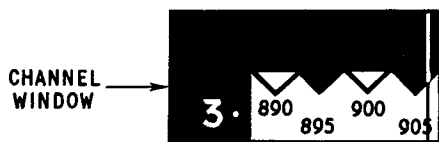

(b) SET SCALE TO NEAREST 100 Kc/s CRYSTAL CHECK POINT (3.900 Mc/s)

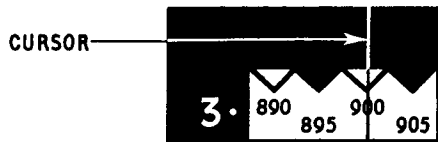

(c) ADJUST CURSOR TO (3.900 Mc/s)

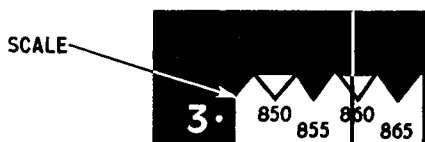

(d) SET SCALE TO NEAREST 10 Kc/s CHECK POINT (3.860 Mc/s)



(e) RE-ADJUST CURSOR TO (3.860 Mc/s)

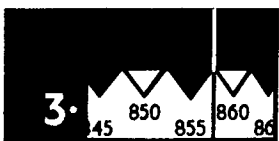

(f) SCALE FINALLY RE-ADJUSTED UNTIL REQUIRED FREQUENCY (3.8575 Mc/s) COINCIDES WITH CURSOR

**FIG. 16A SEQUENCE OF TUNING**

- (10). Turn the system switch to the CHAN ADJ. position.
- (11). Rotate the TUNE control until the 10 kc/s point nearest to the required frequency coincides with the cursor. Fig. 16 inset (d). Continue tuning slowly until the meter indication is centre zero.
- (12). Re-adjust the CURSOR control until the cursor coincides with the chosen 10 kc/s position. Fig. 16 inset (e).
- (13). When the required frequency is an odd 2.5 kc/s as shown in fig. 16A (3.8575 Mc/s), or an odd 5 kc/s as shown in fig. 16B (3.325 Mc/s), rotate the TUNE control until that frequency coincides with the cursor. See fig. 16A inset (f) or fig. 16B inset (f).

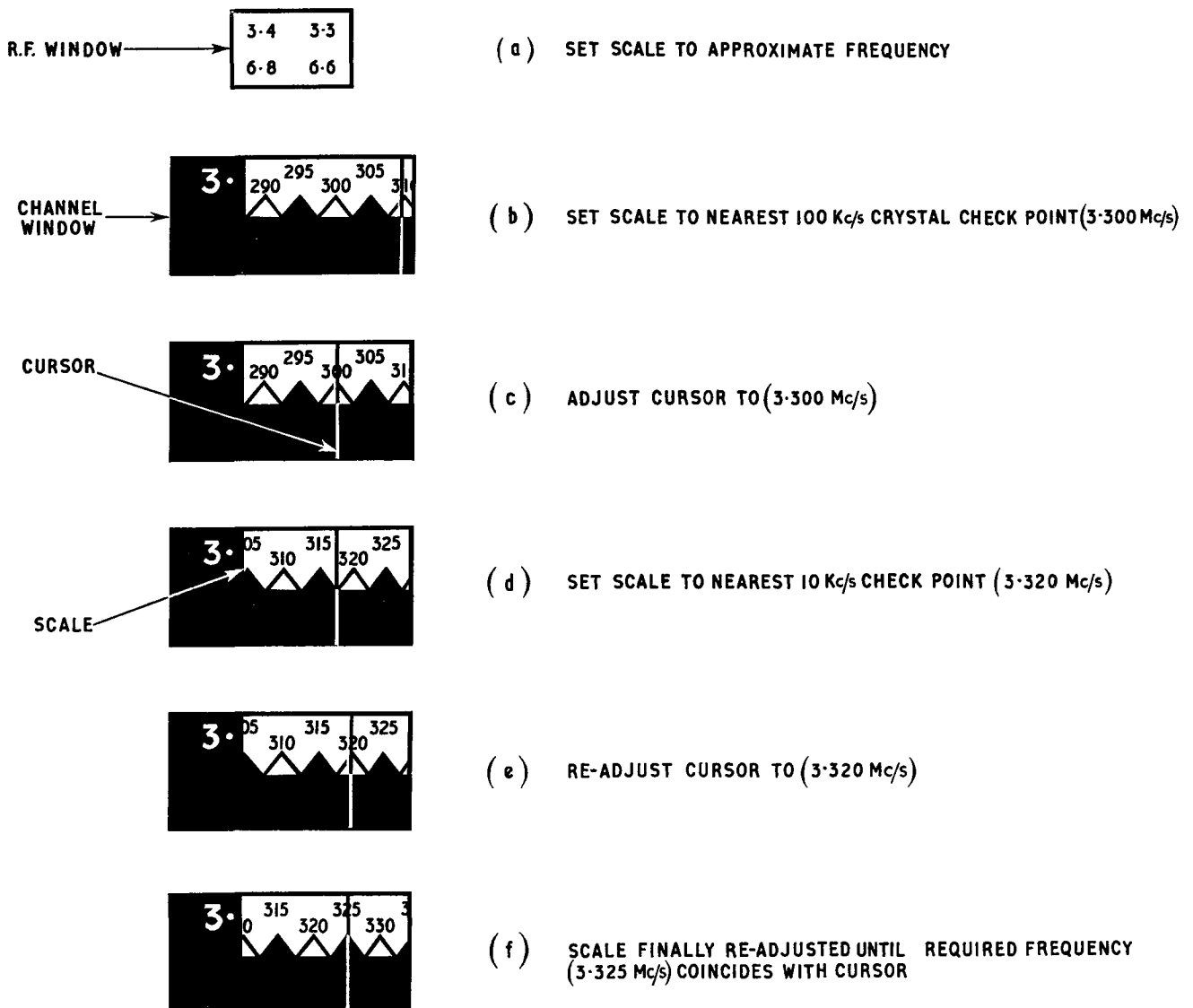

**FIG. 16B SEQUENCE OF TUNING**

- (14) Turn the LOCK control to the RF FREE position.
- (15) Turn the system switch to the TUNE RF position. The transmitter is now ON but is not radiating from the antenna.
- (16) Ensure that when the TUNE control on TR A13 is rocked a small amount in either direction, the meter pointer moves in the same direction as the top of the knob and the RF scale. If it does not, vary the TUNE control slightly in either direction until a point is found where it does.
- (17) Adjust the TUNE control on the TR A13 until the meter indication is centre-zero.
- (18) Move the LOCK control to the LOCK position.
- (19) Turn the system switch on TR A13 to the required position, Ph.M, AM or CW
- (20) Connect headset, handset or key to TR A13 (see fig. 15) and adjust the tuner RF in accordance with section 19 below.

#### Section 19 ADJUSTING THE TUNER RF

- (1) Ascertain the range position for the required frequency and the antenna in use by referring to the table of figures on the plate attached to the side of the tuner RF.

NOTE - the WIRE AE column in the table refers to the 150-ft. braid antenna or to the 26-ft. vertical antenna.

- (2) Turn the RANGE switch on the tuner RF to the appropriate position. See fig. 17.
- (3) Move the LOCK control to the free position.
- (4) Press the pressel switch or the key.

IMPORTANT - This switches the station to 'transmit', therefore do not hold it in the pressed condition for longer than necessary.

- (5) Rotate the tuner TUNE control smoothly until the meter on the tuner indicates a maximum reading.
- (6) Release the pressel switch or the key.
- (7) Move the LOCK control on the tuner RF to the LOCK position.
- (8) The antenna is now matched to the equipment and is ready for operation.

CHECK BATTERY VOLTAGE  
FROM TIME TO TIME DURING OPERATION  
See page 29

NOTE - To adjust the tuner RF when it is remote from the TR A13, as on page 40, it will be necessary to make some arrangement for the handset pressel or the key at the radio equipment to be pressed for the duration of the tuning period. If only one person is available, the remote control unit can be connected to TR A13 and run out to the tuner position. The handset or key can then be connected to one of the sockets on the remote control unit and held in the pressed position whilst the tuner is being adjusted.

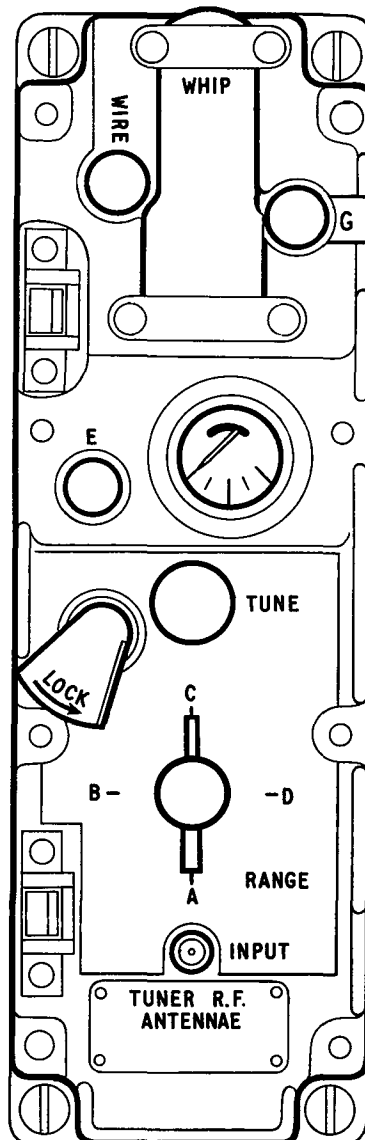

FIG. 17 TUNER RF CONTROLS

Section 20 TUNING THE HP STATION WITH Mk.1 AMPLIFIER

(1.) Checking battery voltage

Check the battery voltage as described in Section 17 on page 29. Note that in the HP station the meter on TR A13 indicates the state of charge of batteries in TR A13 and RF amplifier. If the reading is low, change both batteries.

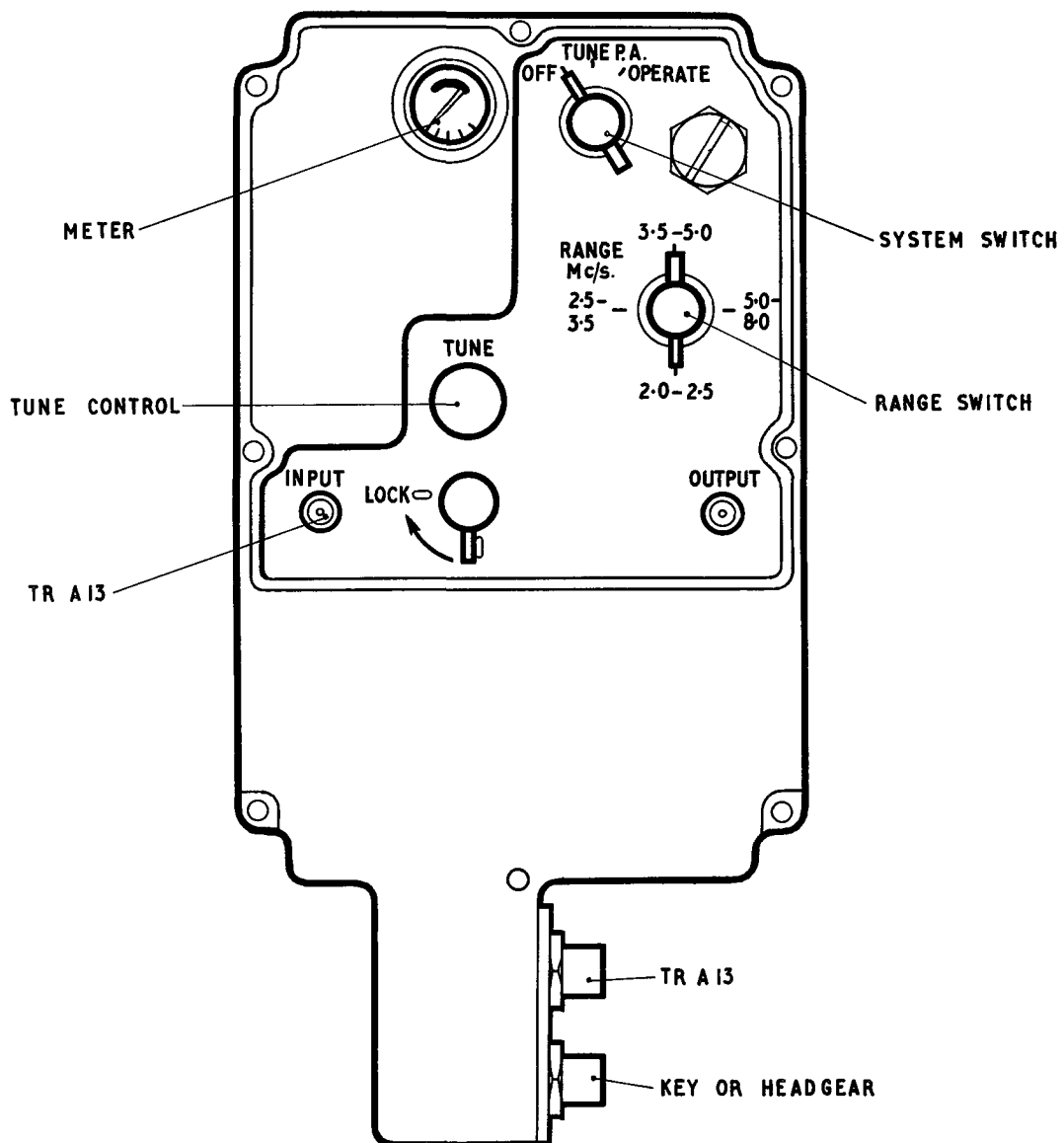

FIG. 18 Mk1 AMPLIFIER CONTROLS

NOTE - If the SR A13 HP has a Mk.2 amplifier, ignore page 35 and turn to page 36.

- (2) Check that the system switch on the RF amplifier is turned to the OFF position. See fig. 18.
- (3) Carry out the tuning instructions for the LP station, as instructed on pages 29 to 33.
- (4) Turn the RANGE switch on the Mk. 1 RF amplifier to select the frequency range required.
- (5.) Turn the system switch on the RF amplifier to the TUNE PA position.
- (6.) Move the LOCK control to the free position.
- (7.) Rotate the TUNE control on the RF amplifier until the amplifier meter indicates a maximum reading.

NOTE - An overload protection circuit is built into the Mk.1 amplifier to prevent damage to the valve; it does not cut the amplifier off but simply reduces the power. This circuit may operate when the RF amplifier is switched to TUNE PA because the circuit will most probably be a long way off tune initially. Then as the tuning point is approached the protection device will automatically release, restoring full power. The tuning operation can be completed without the protection circuit re-operating. This circuit may also operate when tuning the tuner RF on high power (see paragraph 5 on page 32). Once again the protection circuit will release, restoring full power as the tuning point is approached.

- (8.) With the RF amplifier tuned to maximum, turn the LOCK control to the LOCK position.
- (9.) Turn the system switch on the RF amplifier to the OPERATE position.
- (10) Adjust the tuner RF in accordance with section 19 on page 32.

NOTE - To operate the HP station on LP it is only necessary to switch off the RF amplifier. Do not turn the amplifier system switch with the pressel or key pressed down.

Section 21 TUNING THE HP STATION WITH MK 2 AMPLIFIER

- (1) Check that the amplifier is switched OFF. See fig. 19.
- (2) Carry out the tuning instructions for the LP station and tuner RF as instructed on pages 29 to 33.
- (3) Turn the FREQUENCY switch on the amplifier to the range required.
- (4) Switch the amplifier ON.
- (5) To operate the HP station on LP, switch off the amplifier, but release the pressel or the key before doing so.

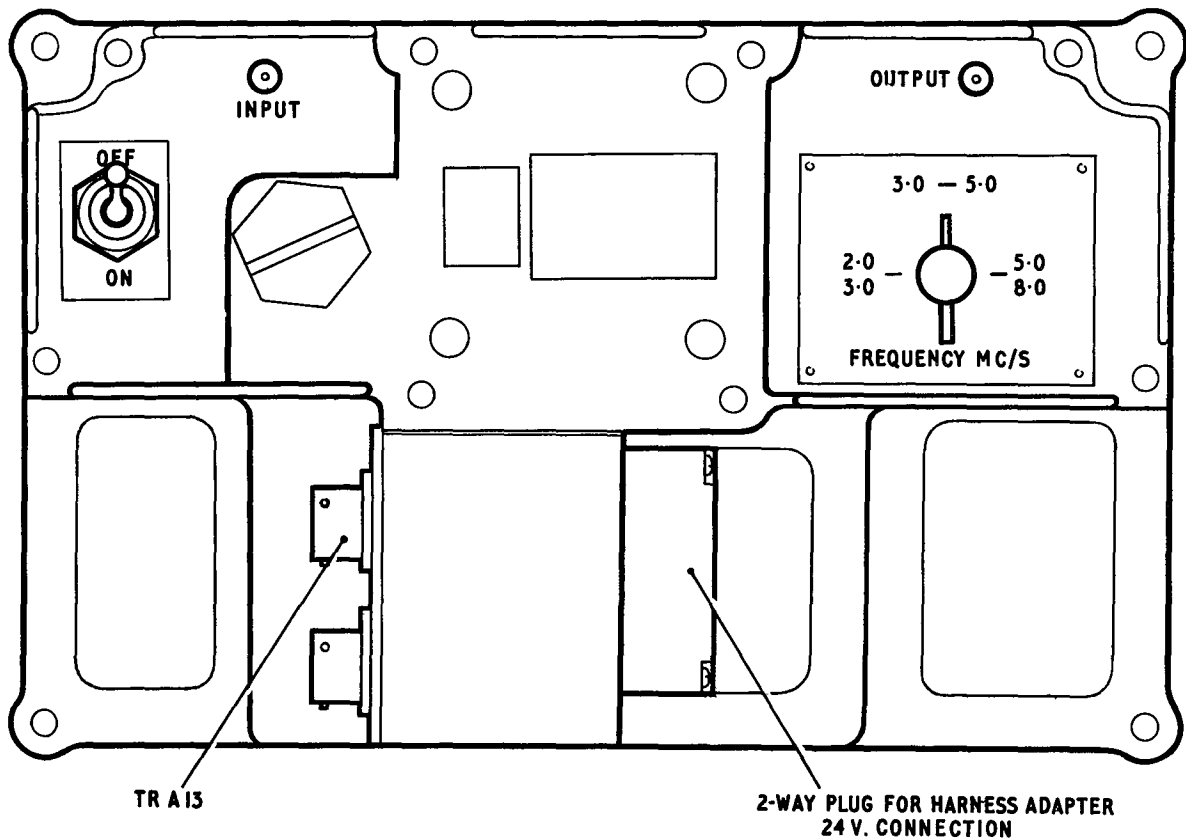

FIG. 19 Mk. 2 AMPLIFIER



(6) Protection circuit on the Mk. 2 amplifier

- (a) A double protection circuit is built into the Mk.2 RF amplifier to prevent damage due to either over dissipation of the power transistors or momentary high transient voltage excursion, either of which could be caused by damage, misalignment or malfunction of the antenna system. Such occurrences will be indicated by a low or zero reading on the meter on the tuner RF.
- (b) Should the transistor base temperature exceed  $+95^{\circ}\text{C}$  a thermal cut-out will prevent further operation until the transistor base temperature has fallen to  $+75^{\circ}\text{C}$ , during which time operation will still be possible on low power by switching the RF amplifier off.
- (c) Should a high voltage excursion occur, avalanche diodes will trigger, removing the RF load from the power transistors.

(7) Action if the protection device operates

Release the pressel for approximately one second, or, if transmitting CW, raise the key for 15 seconds. It should then be possible to resume normal operation.

Section 22 SEARCHING AND NETTING

(1) SR A13 as outstation, other type radio set as control station

- (a) It is possible to "search" on either side of the operating frequency with little loss of signal strength.
- (b) This is achieved by de-tuning the CHANNEL scale to either side of the operating frequency but without disturbing any of the other controls. The AFC circuits will hold the sender frequency to the same frequency as the receiver, within the following limits:

Frequency	Control Limits
2 to 4 mc/s	$\pm 10$ kc/s
4 to 8 mc/s	$\pm 20$ kc/s

- (c) It may be necessary to use SR A13 in conjunction with HF radio sets of other types. If the control station is of modern design it may be tuned accurately to the ordered frequency without reference to any other equipment. An example of this is SR C11/R210. The normal setting up procedure described in section 22 may then be used for SR A13. This is also true if the control station is an SR A510, provided that its frequency is a multiple of 2.5 kc/s.
- (d) If the control station radio set is an older design, a "netting" drill may be required because the control station may not be exactly on the ordered frequency but only near to it. Examples of these older types of set are SR No. 19, No. 62 and C12. Control station procedure for these radio sets will be found in the user handbooks issued with them.
- (e) So far as SR A13 is concerned, the control station will transmit a "netting" call to which SR A13 must be tuned. The procedure to be used is as follows:-
- (f) Set up to the ordered frequency as in pages 29 to 36.
- (g) Turn the TR A13 system switch to AM or CW, depending upon which is to be used.
- (h) Move the LOCK control on TR A13 to the CHANNEL FREE position and adjust the tuning control knob until the control station is heard calling.
- (j) If the control station is not heard it may be a long way off frequency, in which case a large detuning of the CHANNEL scale may be necessary, involving adjustments to the RF scale for maximum noise in the phones.
- (k) Having identified the control station, wait for a netting call or any suitable long transmission.
- (l) Turn the system switch to CW.
- (m) Set the pointer on the CW TONE control to the projection on the panel. In the dark this can be done by touch.
- (n) Adjust the CHANNEL scale for zero beat with the control station signal in the phones.
- (o) Turn the system switch on TR A13 to TUNE RF and the LOCK control to RF FREE.
- (p) Adjust the TUNE control for centre zero on the TR A13 meter.
- (q) Turn the system switch on TR A13 to the required system.
- (r) Re-adjust the tuner RF if necessary.

(2) SR A13 as control station, other type set as outstation

- (a) Instructions on pages 37 and 38 describe a suggested procedure when the SR A13 is joining a net which is controlled by an older type of set.
- (b) Alternatively it may happen that the SR A13 is control station in a net which includes or is joined by older types of radio sets. In this case the normal procedure for establishing communication should be used, as detailed in Signal Training (all arms) Pamphlet No. 7.
- (c) For the "netting" call the SR A13 operator should simply hold the pressel switch depressed for the appropriate time.

Section 23 ANTENNAS

(1) Types of antenna

The choice of antenna will be governed by conditions of use, i.e. the nature of the terrain, the distance over which communication is required and whether day or night use is intended. The following four types of antenna are supplied with SR A13.

(a) 8-ft. whip antenna

Eight sections of small diameter tubing with a retaining wire running through the centre. The 8-ft. whip antenna plugs into the tuner RF, using a flexible adapter to adjust the angle if necessary. See page 40.

(b) 26-ft. vertical antenna

This consists of an 18-ft. mast with the 8-ft. whip antenna fitted in an adapter at the top and a wire from the adapter leading down to the tuner RF at the base. See fig. 21 on page 41.

(c) Dipole antenna

The assembly consists of two 150-ft. braid antennas adjusted in length to suit the operating frequency and connected at the centre to a dipole centre junction. The antenna can be suspended horizontally between the 18-ft. mast and a tree or other improvised support. See fig. 22 on page 42.

(d) End-fed antenna

This consists of one braid antenna, adjusted in length to suit the frequency and suspended from the 18-ft. mast or other suitable support. See fig. 23 on page 43.

WARNING - NEVER ERECT ANTENNAS NEAR OVERHEAD WIRES

(2) Manpack antenna

The only antenna which can be used for manpack operation is the 8-ft. whip antenna and this can only provide ground wave communication. The flexible antenna adapter can be set at any desired angle when walking under trees or if it is necessary to reduce height in order to avoid detection.

(3) Ground station antennas for ground wave working

(a) 8-ft. whip antenna

When the set is placed on the ground for operation, as it should be whenever possible as this improves the antenna efficiency, it is preferable to have the 8-ft. whip antenna in a vertical position. See fig. 13 on page 24.

(b) 8-ft. whip antenna with remote tuner RF and counterpoise

The tuner RF can be dismounted from the manpack frame and erected remotely within 50-ft. of the TR A13 as shown in fig. 20. Such an arrangement should include the counterpoise as indicated. The counterpoise improves the radiation efficiency of the antenna and it should be used with any of the antennas when the earth is dry. It consists of four insulated 30-ft. wires. Spread them out on the ground so that they radiate from the antenna position like spokes from the hub of a wheel. Screw the earth spike into the base of the tuner RF and erect the assembly as shown in fig. 20. Connect the short centre lead on the counterpoise to the unmarked earth terminal on the tuner RF. Fit the 50-ft. coaxial cable between the tuner RF and TR A13 or RF amplifier.

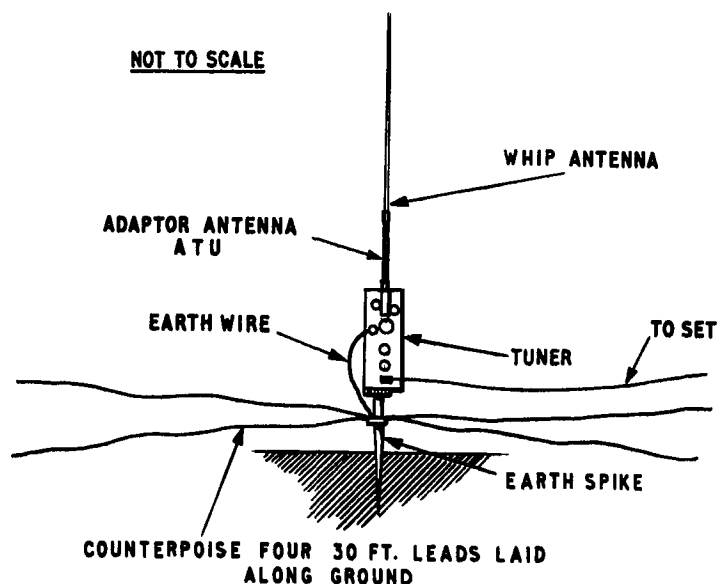

FIG. 20 8 ft. WHIP ANTENNA AND COUNTERPOISE

(c) 26-ft. vertical antenna

If communication cannot be established within the ground wave range using the whip antenna then try the 26-ft. vertical antenna shown in fig. 21.

The 18-ft. mast consists of six tubular mast sections. Fit them together, with one guy frame inserted between the joint of the third and fourth sections and the other at the top of the mast. Fit the adaptor antenna mast to the top of the mast and mount the 8-ft. whip antenna in the socket on this adaptor. See that the 20-ft. down lead, which forms part of the adaptor, is laid out along the side of the mast.

Drive the three guy pins into the ground, equally spaced round the mast position and approximately 9 ft. from it. Raise the mast and place the mast base on the end cap of the mast bag. Tie the six guy ropes to the three pins, with one upper rope and one lower rope to each pin. See fig. 21. Check that the antenna is vertical and adjust the guy ropes as necessary to keep it vertical. Connect the down lead to the terminal marked WIRE on the tuner RF.

This antenna can be used with the tuner RF mounted on the TR A13 or on the earth spike remote from the TR A13.

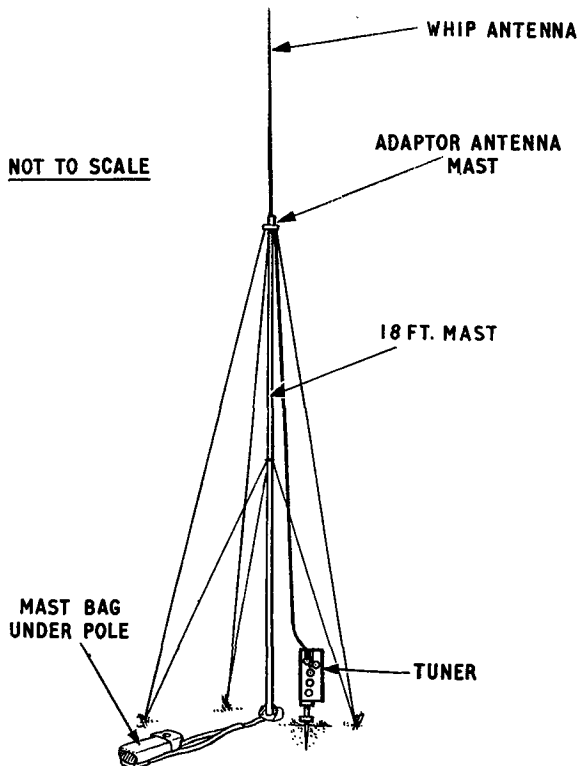

**FIG. 21 26 ft. VERTICAL ANTENNA**

(d) Ground antenna

If it is not convenient to use the 26-ft. vertical antenna a ground antenna can be used. This may consist of 100 ft. or more of insulated wire (such as the remote control cable). If possible, extend it in the direction in which it is desired to communicate. Connect it to the terminal marked 'G' on the tuner RF. Connect the terminal marked 'WIRE' on the tuner RF to the unmarked earth terminal on the tuner RF using a few inches of D10 or similar cable.

(4) Ground station antennas for sky wave working

(a) Dipole antenna

The most efficient antenna provided with the station is the dipole and this should be used for sky wave communication. See fig. 22 below.

For communication under 200 miles in temperate zones the best ground site should be selected, regardless of direction of antenna. For communication under 200 miles in tropical areas all antennas should run NORTH-SOUTH. Should long range communication of over 200 miles be required, the antennas should be erected broadside on to the direction of communication.

The two elements of the dipole consist of two 150-ft. braid antennas wound on frames. Consult the dipole chart on the tuner RF and adjust each element to the length given opposite the required frequency, making use of the markers which are provided every foot along the braid. Make each braid fast to its frame, Connect the free ends of the two braids to the two terminals on the dipole centre junction. Connect the 50-ft. coaxial cable to the socket on the dipole centre junction.

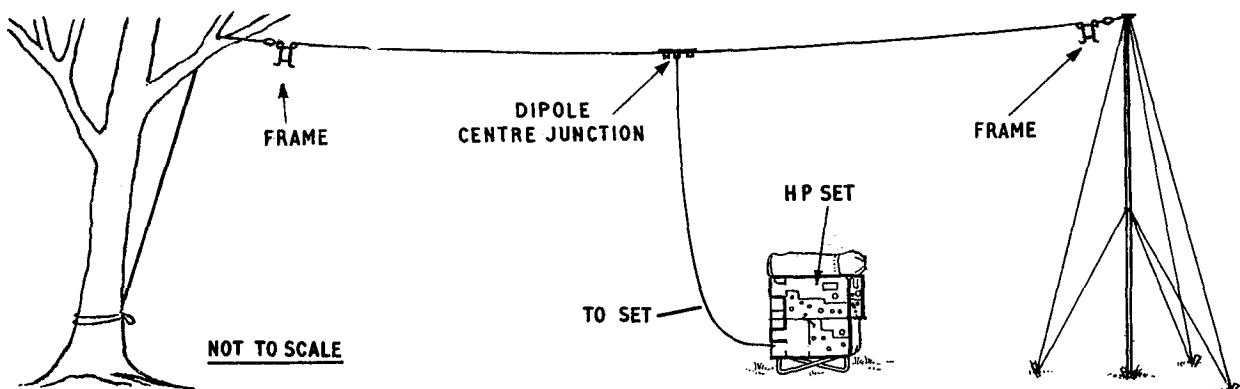

**FIG. 22 DIPOLE ANTENNA**

Raise the dipole antenna between the top of the 18-ft. mast and a tree or other convenient support. See fig. 22. Use the 80-ft. cord supplied in Kit No. 5 to haul up and hold the dipole at the tree end as shown in fig. 22.

If only the 18-ft. mast is available, attach the dipole centre junction to it and take the two free ends to points near the ground. Whichever supports are used, always put the dipole up as high as possible.

Connect the dipole direct to TR A13 in an LP station or to the RF amplifier in an HP station. The tuner RF is not required with the dipole.

(b) End fed antenna

If it is not possible to use the dipole an end fed antenna can be used for sky wave working. Preferably the end fed antenna should be just under three-quarters of a wave length long but for the lower frequencies it is normally only practicable to use it just under a quarter wavelength.

The antenna consists of one 150-ft. braid. Consult the end fed chart on the tuner RF and adjust the braid to the length stated by means of the distinctive markers on the braid. Make the braid fast to the frame on which it is wound.

If the 18-ft. mast is to be used, raise it as instructed on page 41, but instead of the adapter attach the antenna frame to the top of it. See fig. 23. Alternatively a tree or improvised support can be utilised. The antenna should extend from the tuner RF in the direction in which it is desired to communicate. Connect the lower end to the terminal marked 'WIRE' on the tuner RF. If the tuner RF is used remotely as shown in fig. 23, fit it to the spike and connect it to TR A13 by means of the 50-ft. coaxial cable.

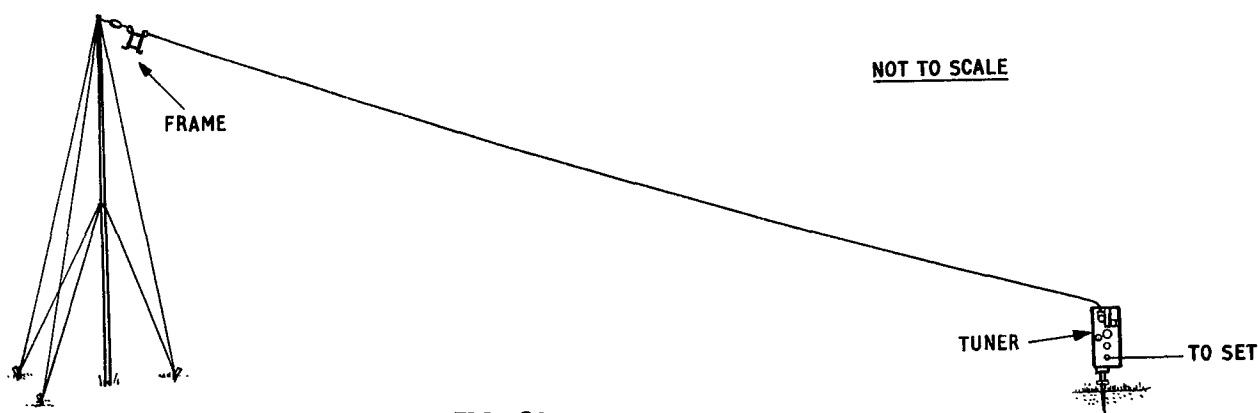

## Section 24 REMOTE CONTROL

### (1) Using the SR A13 remote control unit

SR A13 can be operated by remote control using a handset or headset plugged into the remote control unit. The remote control unit should be connected to TR A13 by means of twisted pair field cable, for which a 100-ft. coil of D10 cable is provided. Alternatively a standard dispenser pack of D10 cable can be used but the maximum length of the remote control cable should not exceed half a mile. Set up for remote control as follows:-

#### (a) Connections

Connect D10 cable between TR A13 and the remote control unit. Connect handset or headgear to either of the 6-way sockets on the remote control unit. Switch the TR A13 on and listen for receiver noise in the earpiece. If receiver noise is present then operation can commence. If receiver noise is absent, reverse the connections of the D10 cable on the remote control unit and check again.

#### (b) RT operation (Ph.M or AM)

Switch TR A13 to Ph.M or AM as required. Switch the remote control unit to RT. Plug in either the handset or headgear, or both, to the sockets on the remote control unit.

#### (c) CW operation

Switch TR A13 to CW. Switch the remote control unit to CW. Connect headgear and morse key to the remote control unit.

NOTE - When the station is being operated by remote control it can still be monitored locally by means of a headset connected to TR A13 or the RF amplifier.

### (2) Using the harness adapter

In vehicle installations where SR A13 is operated through the harness adapter and junction box J1, D10 cable can be connected to the J1 for remote control. The D10 cable should not exceed half a mile in length. At the remote end of the cable a handset S.I. remote control No. 1, which has terminals for the D10 cable, will be required. This handset is supplied in the multi-purpose kit (see page 57).

Switch the J1 to SFT and REMOTE. Further information on remote control is given in the user handbook for radio installation in FFR vehicles, which is supplied in the multi-purpose kit.



Section 25 DIRECT OPERATION FROM AN EXTERNAL 12V BATTERY

(1) SR A13 LP

As an alternative to its internal battery, SR A13 can be operated from a 12V battery such as those used with radio installations in vehicles. The voltage of the external battery must not exceed an absolute maximum of 13V or damage may result to the transistors in TR A13. The external battery must not be on charge nor operating any other equipment at the same time. Connect the battery to TR A13 using the cable supplied with the stabiliser. Plug into the set and attach the clips to the battery terminals. Ensure correct polarity.

(2) SR A13 with Mk. 1 amplifier

Connect the battery to TR A13 as in paragraph 1.

(3) SR A13 with Mk. 2 amplifier

(a) One external battery

Connect TR A13 as in paragraph 1. Connect the Mk. 2 amplifier to the same battery using a second similar connector. Ensure correct polarity. Connected in this way the high power output will be reduced to about 10 watts but TR A13 will function normally.

(b) Two external batteries

Connect two 12V batteries in series to give 24V. Connect TR A13 across the battery which has its '+' terminal connected to the '-' of the other battery as shown in fig. 24. Connect the Mk. 2 amplifier across the two batteries in series. Ensure correct polarity. When connected in this way the station will give full power output.

(c) Three external batteries

Use one for TR A13 as in paragraph 1. Connect the other two in series to provide 24V and connect the Mk. 2 amplifier as in fig. 24.

IMPORTANT - Do not connect 24V to TR A13

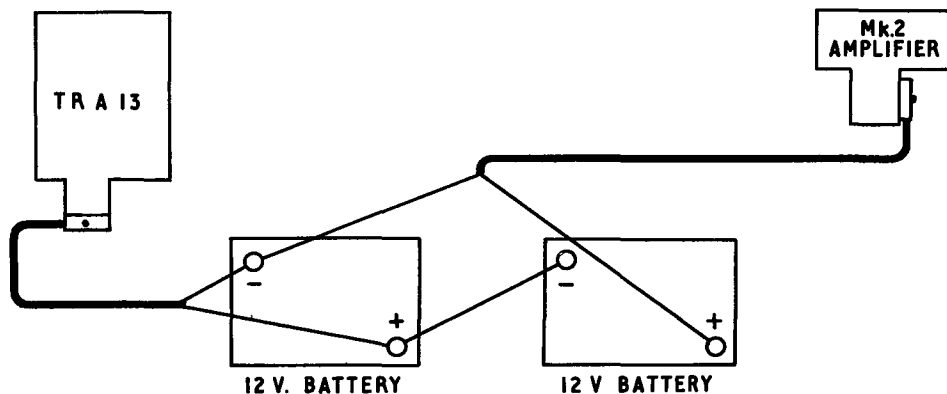
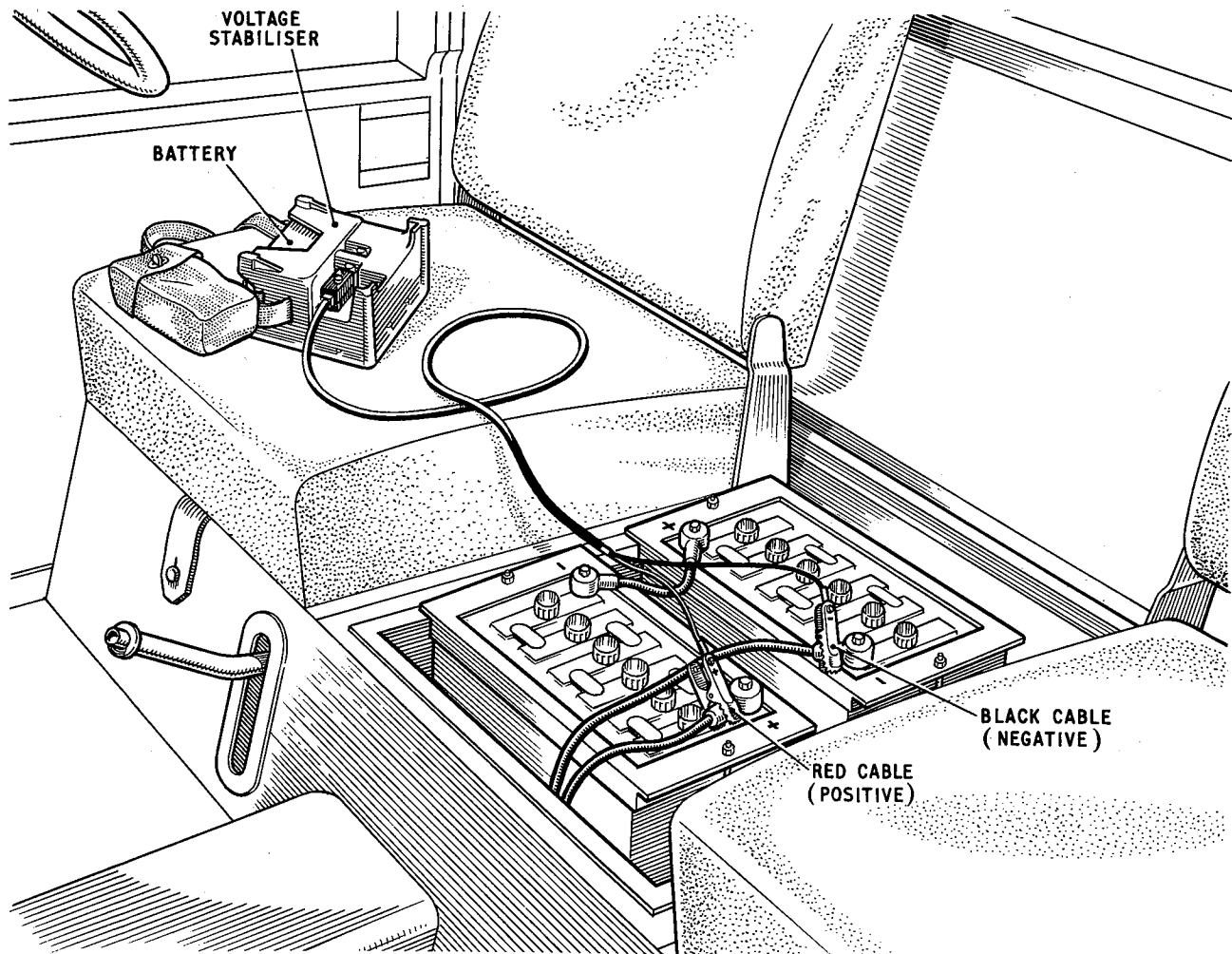

FIG. 24 CONNECTING THE Mk. 2 AMPLIFIER TO TWO VEHICLE BATTERIES

IMPORTANT - In high temperatures, batteries must not be charged for more than two hours at a time



**FIG. 25 BATTERY CHARGING FROM VEHICLE BATTERIES**

IMPORTANT - Take great care to get the polarities correct, i.e. positive (+) clip to positive (+) battery terminal. Polarity is correct when the red lamp on the stabiliser glows. This indicator has a dimming device.

# CHAPTER 3

## BATTERY CHARGING

Three different methods of charging SR A13 batteries are described.

### Section 26 STABILISER VOLTAGE

#### (1) Purpose

The stabiliser is a transistorised unit which charges the 12V A13 battery at a constant voltage from a 24V d.c. source such as vehicle or signal batteries. It is supplied in kit No. 3 as listed on page 11. The battery must be removed from TR A13 or RF amplifier for charging on the stabiliser.

#### (2) Fitting the battery into the stabiliser

Fit the battery to be charged into the stabiliser, engaging the plug and socket, and fasten the strap. See fig. 25, and fig. 5 on page 10.

#### (3) Using vehicle batteries

Before connecting the stabiliser to vehicle batteries, check that the supply is 24V. For example, in Rover trucks the FFR version has 24V supplies but certain cargo Rovers may have 12V supplies. Use the cable provided with the stabiliser. Plug it into the stabiliser and fit the crocodile clips to the battery terminals as shown in fig. 25.

#### (4) Using power take-off terminals in an FFR vehicle

If the installation kit on page 56 is available and the vehicle is an FFR type with power take off, the stabiliser can be connected as shown on page 69. This may be more convenient than the method shown in fig. 25.

#### (5) Charging time

##### (a) Temperature or cold conditions

Leave the battery on charge for six hours. It should then be fully charged. The battery will reach approximately 70% of full charge after one hour and 90% after two hours but to preserve its life it should be fully charged (six hours) whenever possible.

##### (b) High temperature conditions

Leave the battery on charge for only two hours, to avoid overheating.

## Section 27 HAND GENERATOR

### (1) Purpose

The hand generator is supplied in kit No. 6. See page 7. It can be used either for charging the spare battery or for charging the battery or batteries in the equipment, whether or not the equipment is in use at the time. It can be operated from its position on the manpack frame as shown in fig. 13, or mounted to a tree or convenient post by means of the spike as shown in fig. 26.

It would normally be used only when there is no suitable 24V d.c. supply available for the charging method shown on page 47.

### (2) Setting-up

#### (a) Screw mounting

The mounting screw may have been removed for stowage, particularly when the generator is stowed in a vehicle as shown in fig. 37 on page 69. If so, and if the generator is to be mounted as shown in fig. 26, refit it and tighten the four small securing screws. Fig. 12 on page 23 shows the mounting screw fitted.

#### (b) Handle

Release the handle by slackening the wing bolt. Turn the grip outwards to its winding position and pull the handle through the shaft until one of the recesses cut in its length coincides with the wing bolt. This gives the operator different lengths of handle for turning. Tighten the bolt.

### (3) Connections

To connect the hand generator a cable assembly, 2-conductor, 6-ft. in length, is supplied in the generator kit. This cable has plug and socket ends which are so designed that they can only be fitted the correct way round.

#### (a) Charging a spare battery

Connect one end of the cable to the socket on the generator and the other end to the battery. See fig. 26.

#### (b) Charging the batteries in the equipment

To charge the battery in SR A13 LP or both batteries in SR A13 HP, connect the hand generator direct to the 12V socket at the bottom of the TR A13. See fig. 13.

(4) Operation

The handle should only be wound at sufficient speed to keep the red lamp on the generator lit. Violent winding of the handle operates the overload relay, causing the lamp to be extinguished and the battery to go off charge.

NOTE - The battery will NOT be charged any faster by winding harder than is necessary to light the lamp.



**FIG. 26 BATTERY CHARGING WITH THE HAND GENERATOR**

Section 28 CHARGER, BATTERY

(1) Purpose

Charger battery (6130-99-103-2895) is used to charge SR A13 batteries at a central position, using a petrol driven generator.

The A13 batteries must NOT be connected direct to the charger nor to the generator. Each battery to be charged is fitted into a stabiliser and the stabiliser is connected to the charger. See fig. 27. Any number of stabilisers from one to five can be connected to one charger.

Two suitable types of generator in service are the 300 watt 24 volt generator with which one charger only can be used, and the 1260 watt with which one, two or three chargers can be used.

(2) Using a 300 Watt generator

- (a) Ensure that both switches on the charger are in the upward position.
- (b) Connect the INPUT terminals of the charger to the output terminals of the generator, using the twin lead provided. See that polarity is correct.
- (c) Start the generator. If the meter on the charger reads backwards the polarity of the connections to the generator is wrong and must be reversed.
- (d) Adjust the output control on the generator to make the meter on the charger read 28 volts. If the meter reading with the output control at its minimum position is greater than 28 volts, move the REDUCE VOLTS switch to its downward position and then adjust for a reading of 28 volts; this switch must then be left in the downward position until the period of charging is finished and the generator is stopped.
- (e) The handles of the charger are used as output bus-bars. Connect the required number of stabilisers (any number from one to five), each with its battery in position, to the output bus-bars, observing correct polarity. Fig. 27 shows one stabiliser connected.
- (f) Switch the charger OUTPUT ON. If the red lamp on any of the stabilisers does not glow the polarity of the connections to that stabiliser is incorrect and should be reversed.
- (g) When the load is applied the voltage shown on the meter will drop slightly. If it falls below 18 volts adjust the output control on the generator to raise it to 18 volts.

NOTE - If at any time during the charging period the reading on the meter rises above 28 volts the generator output control must be adjusted to reduce it. Keep the voltage between 18 and 28 by adjusting the generator output control.

- (h) The batteries will be practically fully charged after two hours and may be used if required urgently, but to preserve their life they should be left on charge for six hours if this is possible, except in high temperatures, when the charging time must be restricted to two hours.
- (j) If the number of stabilisers connected originally was less than five, more can be added while charging is still in progress. Those which have completed their requisite charging period, or are needed for use, can be removed without switching off.
- (k) If it is required to remove the charged battery from one of the stabilisers and replace it with a discharged one, this can be done without switching off the charger or disconnecting the stabiliser.
- (l) When charging is finished, switch the charger OUTPUT switch OFF and stop the generator.

NOTE - In high temperatures batteries must not be charged for more than two hours at a time.

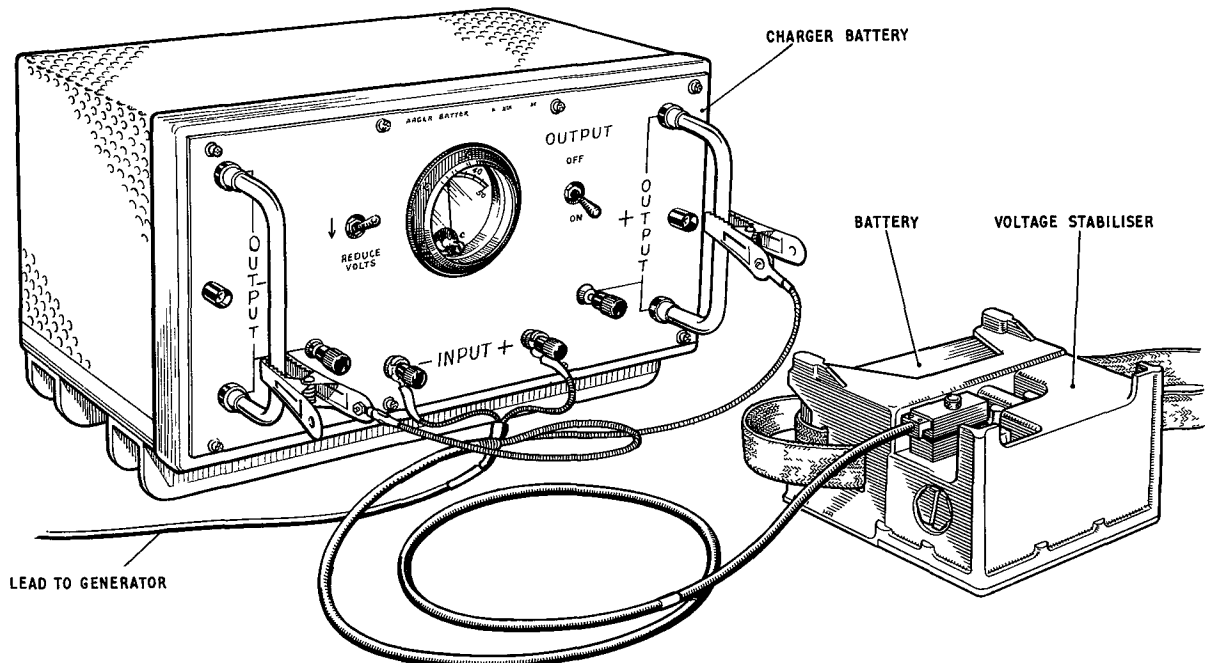

**FIG. 27 BATTERY CHARGING WITH THE CHARGER BATTERY**

(3) Using a 1260 Watt generator

- (a) One, two or three chargers can be used with this generator. Connect the INPUT terminals of all the chargers to the output terminals of the generator.
- (b) Operation thereafter is the same as for the 300 watt generator.
- (c) Any one of the meters may be used when adjusting the output control of the generator. If it is necessary to operate the REDUCE VOLTS switch in order to get a reading of 28 volts then the switches on all the units must be set to the downward position.

IMPORTANT NOTE - These operating instructions make no reference to the operation and maintenance of the engine of the generator. For this information the handbook of the generator should be used. All reference to adjustment of the generator output in that handbook MUST BE IGNORED or damage will result to the stabilisers and batteries.

AT NO TIME should any regard be paid to the reading of the meter on the generator.



# CHAPTER 4

## VEHICLE INSTALLATION

NOTE - There are two different methods of installing SR A13 in 'B' vehicles: harness adapter (pages 53 to 71) or clip-on (pages 72 to 78).

### Section 29 USING THE HARNESS ADAPTER

#### (1) Purpose

The harness adapter enables SR A13 LP or SR A13 HP to be connected to a junction box J1 and to the control harness through which other radio equipment in the vehicle is operated. It also enables SR A13 equipment to take its power supply from the vehicle 24V power supply source. When TR A13 and the RF amplifier are installed on the harness adapter their internal batteries must be taken out.

The harness adapter can be used either with the Mk.1 amplifier or with the Mk. 2 amplifier. When it is used with the Mk. 2 amplifier a separate connection provides the 24V d.c. supply required by the Mk.2 amplifier when it is on 'transmit'. When the harness adapter is used with the Mk. 1 amplifier this 2-way cable is not fitted.

#### (2) FFR 'B' vehicles in which the harness adapter can be fitted

With the equipment shown in the lists on pages 55, 56 and 57 the harness adapter can be fitted in FFR (fitted for radio) versions of the following 'B' vehicles:

Truck FFR 1/4-ton Rover Mk. 8  
Truck FFR 3/4-ton Rover Mk. 9  
Truck FFR 1-ton Austin K9  
Truck armoured FFR 1-ton Humber  
Truck radio FFR 1-ton Austin K9

NOTE: In these instructions the near side of the vehicle is referred to as the left hand side and the off side as the right hand side.

(3) Where the harness adapter should be fitted

(a) Trucks without any radio sets on the table

Mount the harness adapter at the left hand end of the radio equipment table and use the left hand antenna mounting for the SR A13 antenna.

(b) Trucks with VHF set or sets on the table

If a radio set C42 or C45 is fitted at the right hand end of the table, mount the harness adapter at the left hand end. If a B47 is fitted at the side of the C42, move it to the top of the C42 to make room for the harness adapter. See page 58.

(c) Trucks with one HF set on the table

If an HF radio set (C11-R210, C12 or C13) is fitted at the left hand end of the table, mount the harness adapter at the right hand end and use the right hand antenna mounting for the SR A13 antenna.

(4) Preparing the vehicle

(a) Holes to fit the harness adapter must be drilled in the table top. If a VHF set at the right hand end of the table is to be moved, a new group of holes must be drilled for it. See page 58. These holes should be drilled by R.E.M.E. workshops or under unit arrangements.

(b) Apart from the drilling of holes in the table top, no prior workshops action is required on any of the FFR vehicles in paragraph 2 on page 53. When the necessary holes have been drilled the installation can be completed by the user in accordance with the relevant instructions in this chapter.

(5) Other vehicles

(a) 'B' vehicles

No special provision is made for fitting the harness adapter to any make or type of 'B' vehicle other than those listed above although the installation in other 'B' vehicles could be improvised adhering to the same general principles.

(b) 'A' vehicles

Arrangements have been made to install SR A13 HP on a harness adapter in certain 'A' vehicles, for example FV 432 (see CES 43208).

Section 30 KITS REQUIRED

(1) Manpack equipment

Equipment from the following SR A13 manpack kits is used when the SR A13 is installed on the harness adapter in FFR 'B' vehicles:

- (a) Station kit radio No. 1, TR A13.  
Details on page 5.
- (b) Station kit radio No. 3, Voltage regulator.  
Details on page 11.
- (c) Station kit radio No. 4, TR A13, Amplifier RF No. 12 Mk. 1

OR

Station kit radio No. 8, TR A13 amplifier RF No. 12 Mk. 2.  
Details on page 7.

- (d) Station kit radio No. 6, TR A13 hand generator.  
Details on page 7. (If required).

(2) Vehicle installation equipment

Equipment for the installation of the harness adapter is provided in the following three kits.

Details are given in CES 43207.

- (a) Station kit radio No. 11, TR A13 vehicle conversion.

(Z1/5820-99-105-4020)

DESCRIPTION	REMARKS
Harness adapter, 12V and 24V (5820-99-105-3155)	For Amplifier RF No. 12 Mk. 1 or Mk. 2.
Cable assy. 2-condr. 14-in. (5995-99-105-3159)	Harness adapter to Mk. 2 amplifier (Mk.4 plug - twin socket) (Connector W-X in fig. 34) Not used with Mk. 1 amplifier
Cable assy. 6-condr. 2-ft. 2-in. (5995-99-949-6860)	Harness adapter to TR A13 (Connector J-K in fig. 32)

(b) Installation kit electronic equipment, A13 harness adapter

DESCRIPTION	REMARKS
Antenna element, 49 $\frac{1}{2}$ -in.	Top section of 12-ft. antenna
Base antenna support (5820-99-949-3482)	See fig. 31
Batten terminal 2-pt. No. 4	Used with stabilisers. See page 69
Batten terminal mounting plate	See page 69 para. 4.
Bracket stabiliser, 8 $\frac{3}{4}$ x 4.7 $\frac{7}{32}$ x 6 $\frac{7}{8}$ -in. (5820-99-103-6926) (two)	To mount stabilisers on slotted angle framework.
Bushing rubbers (5340-99-103-4883)(four)	Used on antenna lead. See fig. 31.
Cable assy. 2-condr. 1-ft. 3-in.	Batten terminals to LT box (loop ends - Mk. 4 plug)
Cable assy. 2-condr. 7-ft. 9-in. (two)	Batten terminals to stabiliser (loop ends - 2-pin plug)
Cable assy. 12-condr. 3-ft. 6-in.	Harness adapter to J1 (M-O in fig. 32)
Cable electric, 1 condr. 44/0.012 (Y3/6145-99-900-7962) (4 yd.)	Antenna lead (A-B in fig. 32)
Clamp antenna base (5820-99-949-3038)	
Connector copper braid No. 23, 12-in. (ZA 54056)	Copper braid earth lead (F-Q in fig. 32)
Hand generator stowage clamp	See page 71.
Insulators bowl (5970-99-103-5758)(50)	Used on antenna lead. See fig. 30
Interconnecting box 4-way No. 4 (5820-99-949-0960)	LT box. See fig. 29.
Nut gland and washer (ZA 50365)	Used on antenna lead.
Plate plastic, $\frac{1}{4}$ -in. x 5-in. (ZA 50358)	Fitted under antenna base
Plug and nut assembly (5820-99-103-6908)	Connects lug on antenna lead to tuner RF
Screws UNF hex $\frac{1}{4}$ x $\frac{5}{8}$ -in with nuts, flat and spring washers (two)	To secure the strap (see page 69)
Screws UNF hex, 5/16 x 7/8-in with nuts and spring washers (two)	To bolt the LT box to the slotted angle framework
Spanner wrench (5120-99-103-5591)	To screw nut gland into base
Strap web, 4-ft. 2 $\frac{1}{4}$ -in. (Y1/5340-99-901-0685)	To stow manpack carrying frames
Support harness adapter (5820-99-104-1985) (two)	Pillars to support the ends of the harness adapter
Terminal set quick disconnect (5940-99-103-5577)	Lug to fit at tuner end of antenna lead

(c) Installation kit electronic equipment multi-purpose radio, 24V

One of these multi-purpose kits is required to fit a radio set into an FFR vehicle. Contents of the kit are listed in the latest issue of CES No. 42900. For the harness adapter installation in Rover Mk. 8 or 9 FFR the following items are required from the multi-purpose kit.

DESCRIPTION	REMARKS
Antenna element, 49 $\frac{1}{2}$ -in.	Antenna centre section
Antenna element, 49 $\frac{1}{2}$ -in.	Antenna bottom section
Cable electric D10	Remote control
Case antenna	
Case maintenance kit	Holds spare fuses and lamps
Connector twin No. 400, 3-ft. (ZA 54389) (two)	LT box to J1 (R-S in fig. 32) LT box to harness adapter (L-M in fig. 32)
Connector 4/2-pt. No. 4, 5-ft. (ZA 51401)	LT box to power supply (T in fig. 32)
Handset S1 remote control	
Haversack	Headgear stowage
Headsets earphone	
Interconnecting box J1, 24V, Mk.2	Operator's control unit
Microphone hand	
Perforated plastic strip and studs	To strap cables down
Screws UNF, 5/16 x 7/8-in. (four) with nuts and washers	To bolt the J1 to the slotted angle framework
User handbook for radio installations in FFR 'B' vehicles (Code No. 12798)	Installation handbook

For harness adapter installations in FFR vehicles other than Rover Mk. 8 or 9 the following items are also required from the multi-purpose kit.

Cable assembly twin, 6-ft. 6-in. (5995-99-949-1001)	LT box to battery (See page 65 para. 3)
Lead electrical single, 2-ft. 6-in. (5995-99-949-1068)	Battery series connector
Lead electrical single, 3-ft. (5995-99-949-1000)	Battery earth

## Section 31 MOVING VHF RADIO SETS

### (1) Moving the VHF set at the right hand end of the table

If SR C42 or C45 is installed at the right hand end of the table it can still be used there but it must be moved further to the right to give more space for the harness adapter. Remove the connectors and take out this set. After removing the table top, take off the carrier. Keep all the screws, nuts, washers, etc., ready for refitting after new holes have been drilled. This should be done when the table is being drilled for the harness adapter as shown in paragraph 2 opposite.

### (2) Drilling the table for repositioned C42 or C45

Drill a new group of six holes as follows: a hole should already exist through the steel channel at 'A' in fig. 28. Continue this hole through the wooden table top. Use it instead of the hole 'B' in fig. 28 and with the carrier thus located, mark off and drill the remaining holes 5/16-in. dia.

### (3) Refitting the VHF set

Bolt the carrier down in the new position before refitting the table. Secure it by means of the original screws, nuts, washers, etc. After fitting the table into the truck, clamp the C42 or C45 and the supply unit into its repositioned carrier. Refit the top tray, control harness and connectors ready for use. See the installation handbook.

### (4) C42/B47 installation

To make room for the harness adapter in an FFR vehicle which contains C42 and B47, the B47 is moved to the top of the C42. Additional fittings for this are provided in a separate installation kit.

DIMENSIONS TO OUTER FACE OF TABLE FRAME

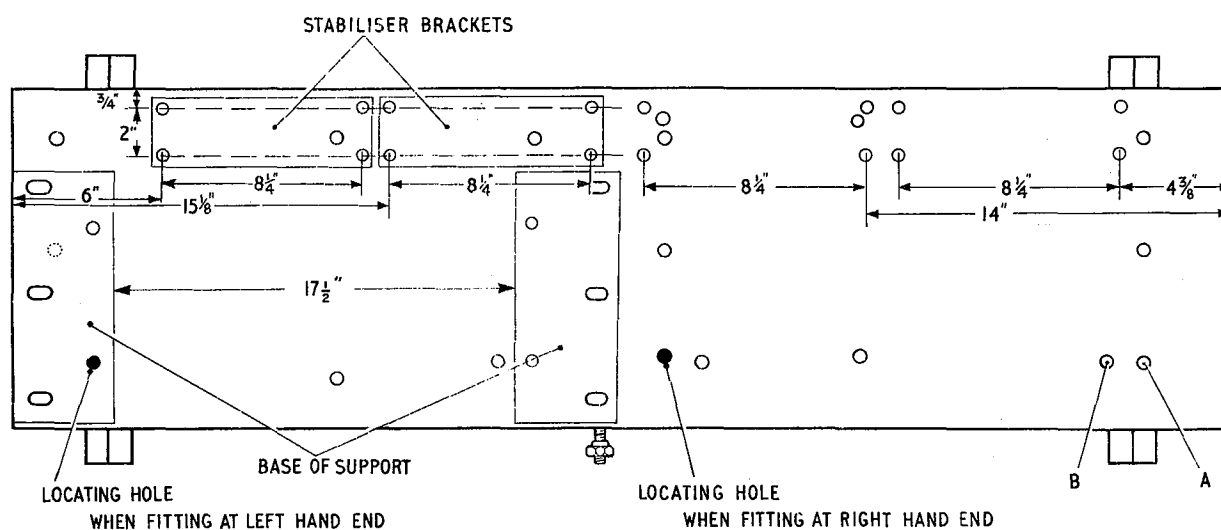

**FIG. 28 TABLE DRILLING DIAGRAM**

## Section 32 FITTING HARNESS ADAPTER AND SR A13

### (1) Removing the table

The table is already installed in FFR trucks but in order to fit the supports for the harness adapter it will have to be taken out. See the relevant chapter in part 2 of the installation handbook. Take off the four table clamps, slide the table partly off, release the earth braid and lift the table out.

### (2) Drilling the table for the harness adapter

Locate the harness adapter as in paragraph 3 on page 54.

#### (a) At the left hand end of the table

When the harness adapter is to be fitted at the left hand end of the table, position the left hand support as shown in fig. 28. Locate it using the existing hole in the table as indicated. Mark off and drill the remaining four holes for the left hand support. All holes should be 5/16-in. dia. The three outer holes pass through the frame. Position the right hand support as shown, with 17 $\frac{1}{2}$ -in. between inner edges of the support bases. Mark off and drill five holes for the right hand support.

#### (b) At the right hand end of the table

If the harness adapter is to be fitted at the right hand end of the table, locate the left hand support on an existing hole near the centre of the table as indicated. Mark off and drill the remaining holes for left hand and right hand supports in exactly the same manner as for the left hand position.

### (3) Other drilling

Any other necessary holes should be drilled before the table is refitted. These may be required for the VHF set (see section 31 (1) opposite) or for the stabiliser stowage brackets (see paragraph 3(a) on page 69.

### (4) Fitting the supports harness adapter

Before replacing the table in the vehicle, bolt the two supports to the table top. Fig. 28 shows the positions, fig. 29 shows the supports fitted. Each is secured by means of five screws with spring washers and nuts fitted underneath the table.

### (5) Re-fitting the table and earth braid

After fitting the two supports for the harness adapter, and the carrier for any other radio set which is to be installed on the table, replace the table in the vehicle. Position it partly on the runners, reconnect the earth braid between the underside of the table and one of the bolts holding the right hand mounting. Slide the table back to its correct position, refit the four clamps and tighten them firmly by hand.

(6) Fitting the harness adapter

Position the harness adapter on the tops of the two supports as shown in fig. 29. Secure it by means of four screws fitted down through the centres of the resilient mounts and tightened with a box spanner.

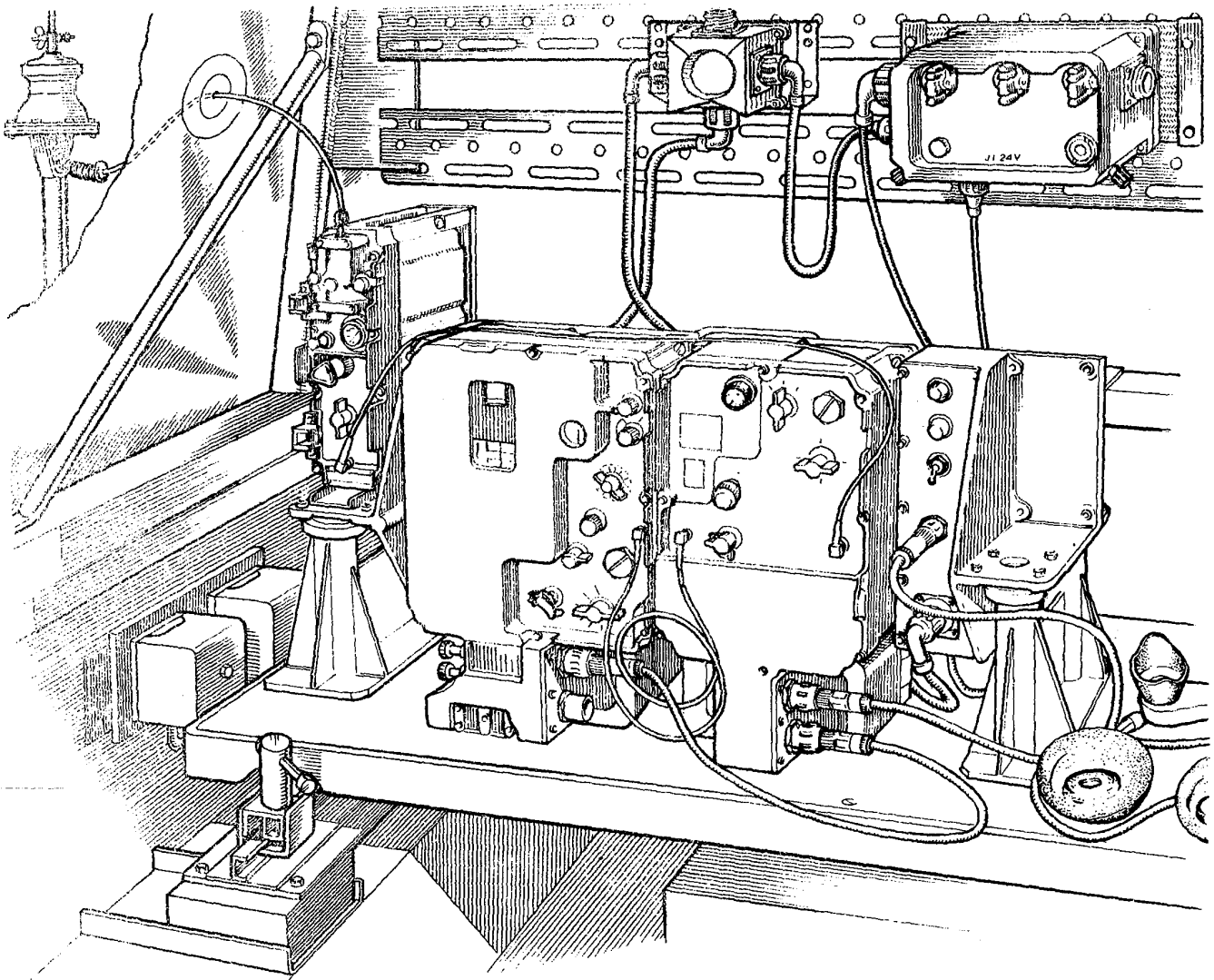

**FIG. 29 HARNESS ADAPTER INSTALLED WITH SR A13 AND Mk.1 AMPLIFIER**



(7) Fitting A13

Dismantle TR A13 from the manpack carrier and remove the battery from it. Position TR A13 at the left end of the harness adapter as shown in fig. 29 and fasten the retaining screws.

(8) Fitting the tuner RF

The tuner mounting plate is temporarily attached to the harness adapter during storage. Take it off in order to fit the tuner. Position the plate against the back of the tuner with the four fixing holes at the bottom and fasten the tuner to the plate by means of the four corner screws. Then position the tuner on the harness adapter in the end section adjacent to the antenna base on the truck. Fig. 29 shows it at the left hand end. Secure it by means of four screws inserted through the vertical face of the harness adapter into tapped holes in the plate.

(9) Fitting the RF amplifier

If the RF amplifier is to be installed, remove the battery from it and fit it to the harness adapter at the right hand side of TR A13. Fig. 29 shows the harness adapter with the Mk. 1 amplifier fitted. Fig. 33 on page 66 shows the harness adapter with the Mk. 2 amplifier fitted.

Section 33 FITTING J1 AND LT BOX

(1) Fitting the J1

Bolt the J1 to the slotted angle framework as shown in fig. 29. Four screws with nuts and washers are provided in the multi-purpose kit.

(2) Fitting the LT box

Bolt the LT box to the slotted angle framework at the side of the J1. Two screws, nuts and washers are supplied in the installation kit on page 56.

Section 34 FITTING ANTENNA BASE AND LEAD

(1) Antenna lead

Make a lead of the exact length to reach between the antenna base and the tuner RF, calculating the length of cable required as described in paragraph 5 on page 63. The base end of this lead must be fitted at the same time as the antenna base. Component parts are supplied in the harness adapter installation kit on page 56.

(2) Fitting the antenna lead to the antenna base

Strip the insulation back for half an inch at one end of the cable. Thread this end through the gland nut and washer supplied with it. Splay the wires out over the washer. Tuck them under it to retain them and slide the gland nut up to the washer. See fig. 30. Screw the gland nut into the antenna base using the tool supplied with it.

(3) Clamping the antenna base to the mounting on the vehicle

The clamp secures antenna base and plate plastic to the flange at the top of the mounting without the use of screws and nuts. See fig. 31. To fit it, thread the free end of the cable through the centre of the plate plastic and the top frame of the mounting. Position the plate plastic against the top of the mounting and line up the six bolt holes. Fit the two halves of the clamp on the top of the plate plastic with the screw clamp upwards and engage the two dowel pins in any two adjacent holes. Position it so that the clamp does not project outwards from the side of the vehicle. Open the clamp sufficiently to allow the antenna base to be fitted on the two dowel pins. Close the clamp so that the holding lugs grip the mounting flange underneath and the antenna base on the top. Tighten the wing nut to secure the assembly.

(4) Fitting the insulating beads on the cable

Thread on the cable one rubber clamp, 25 beads with the open ends downwards, and the second rubber clamp. Position the beads to prevent the cable touching the mounting. When the hood is fitted, thread the cable through the hole provided near the antenna mounting. Inside the vehicle, thread on the cable another rubber clamp, the remaining 25 beads, and the fourth rubber clamp.

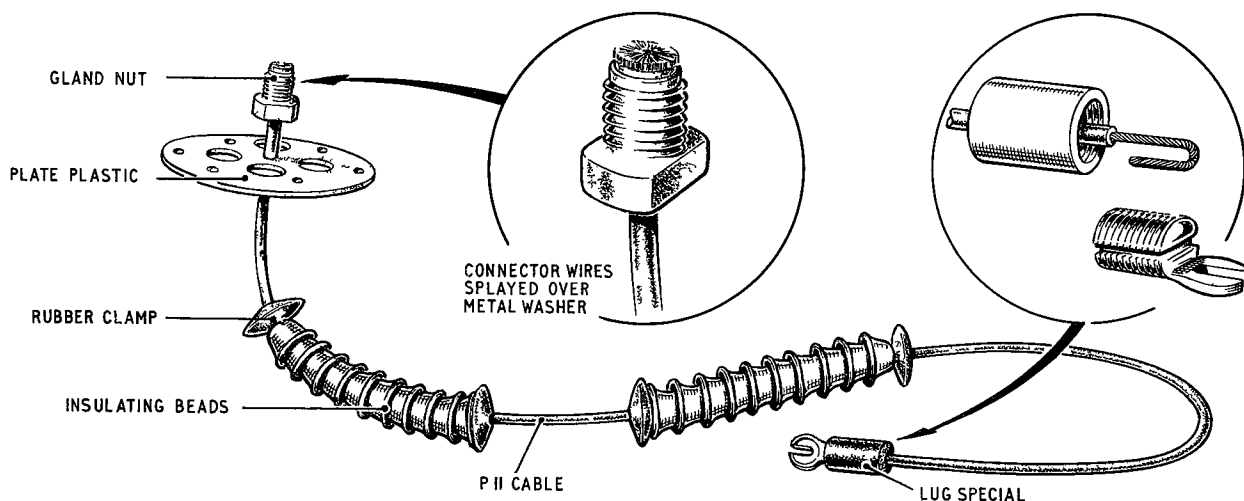

**FIG. 30 MAKING THE VEHICLE ANTENNA LEAD**

(5) Cutting the antenna lead to the required length

Do not cut the cable before the tuner RF is installed. After fitting the tuner check the length required to reach it. The lead should be as short as possible without straining it as it must not touch any metal projections such as the corners of sets, etc. Allow approximately 4 in. sideways movement in the centre of the cable so that the flexing of the antenna base does not strain it. Allow 1-in. for the loop inside the lug and cut the cable.

NOTE - The lead is an effective part of the antenna and must be kept as short as possible or tuning calculations will be upset and there will be a loss of output.

(6) Fitting the lead to the tuner RF

Strip the insulation for  $1\frac{1}{2}$ -in. and twist the wire strands firmly together. Remove the bush from the body of the lug and slip it onto the cable. Fit the wire into the groove in the side of the lug. Screw the bush onto the lug to grip the wire. See fig. 30. Fit the lug to the plug and nut assembly and tighten the terminal to retain it. Insert the plug into the WHIP socket on the tuner RF.

(7) Fitting the vehicle antenna rod

When it is required for use, fit the vehicle antenna into the antenna base. A 12-ft. rod should normally be used.

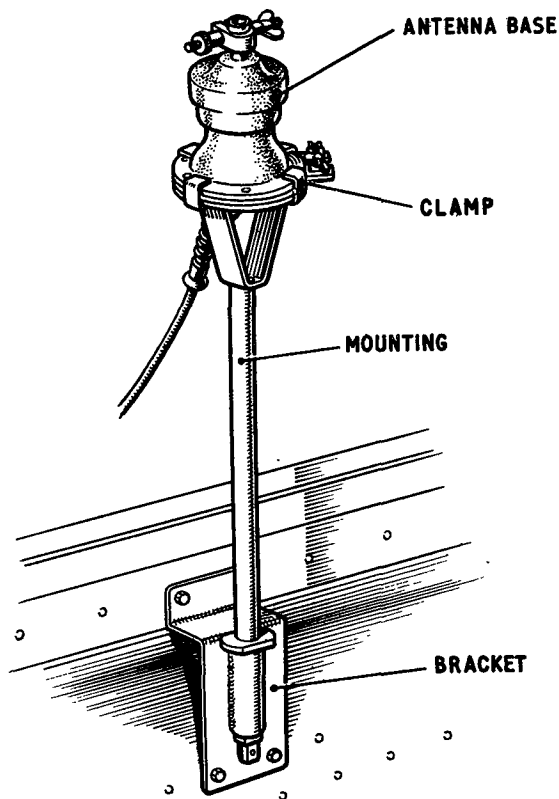

FIG. 31 FITTING THE ANTENNA BASE

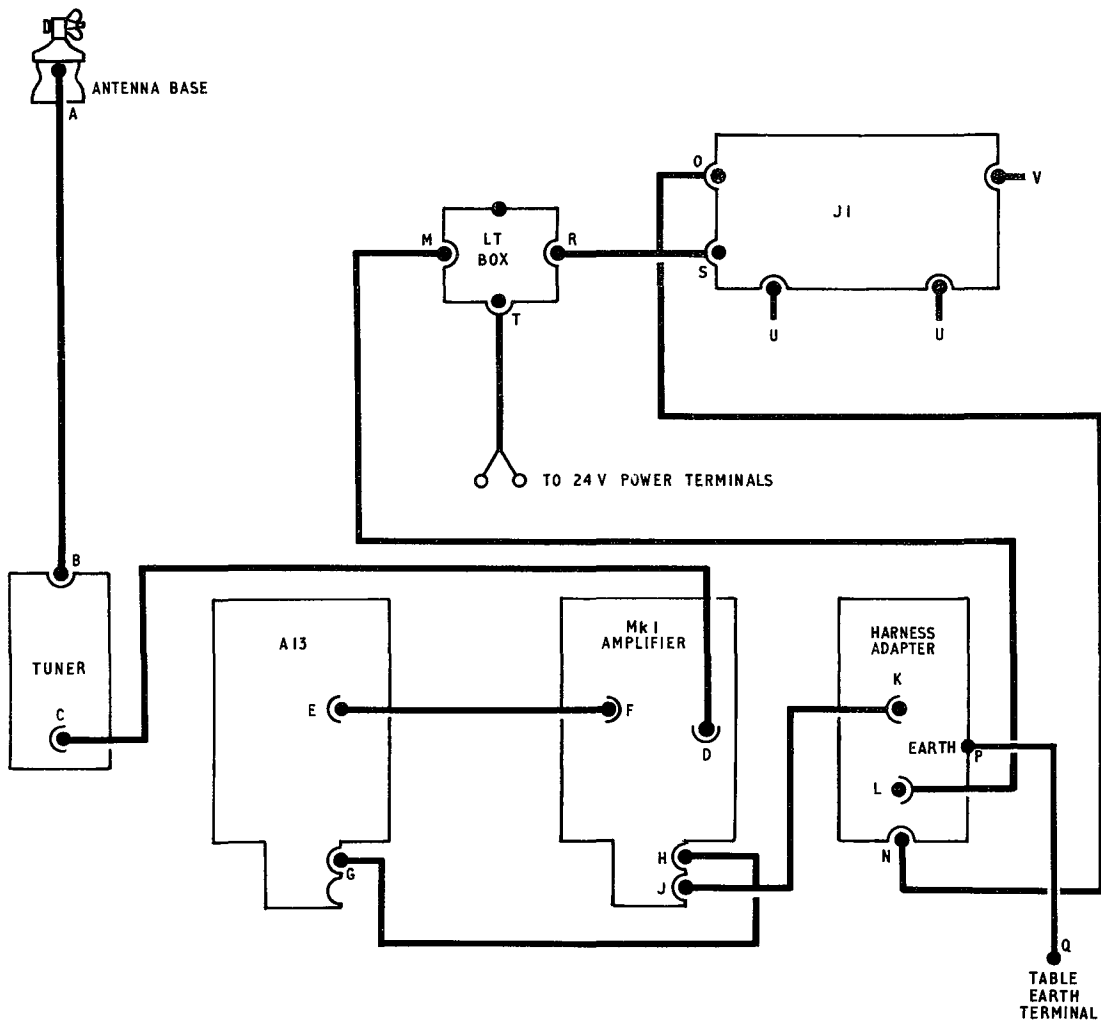
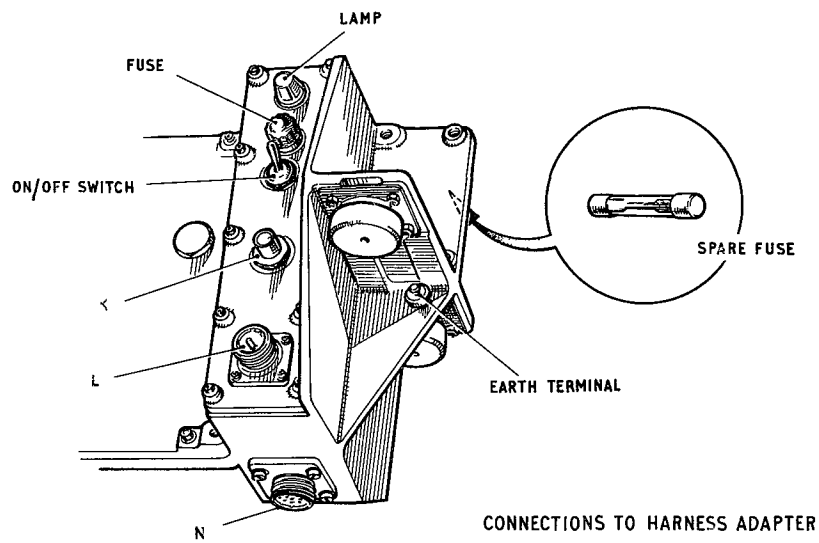

FIG. 32 CONNECTOR DIAGRAM-Mk.I AMPLIFIER

Section 35 CONNECTORS FOR SR A13 HP WITH Mk.1 AMPLIFIER

(1) Connections for SR A13 HP

Fit the connectors shown in the following list and in fig. 32. When fitting the twin connector 'T' between the LT box and the 24V power supply terminals, make sure that polarity is correct. If positive and negative leads are reversed the equipment will be damaged.

Fig. 32 ref.	Connector	Obtained from
A - B	Antenna lead	Made by user. See page 62.
C - D	Cable assy. RF, 2-ft.	A13 kit No. 1.
E - F	Cable assy. RF, 2-ft.	A13 kit No. 4 or No. 8.
G - H	Cable assy. 6-condr. 2-ft.2-in.	A13 kit No. 4 or No. 8
J - K	Cable assy. 6-condr. 2-ft.2-in.	A13 kit No. 11.
L - M	Connector twin No. 400, 3-ft.	Multi-purpose kit
N - O	Cable assy. 12-condr. 3-ft.6-in	Harness adapter installation kit.
P - Q	Copper braid, 12-in.	
R - S	Connector twin No. 400, 3-ft.	Multi-purpose kit
T	Connector 4/2-pt. No. 4, 5-ft. (all trucks except Austin see below)	Multi-purpose kit
U	Headset	Multi-purpose kit
V	For connection to another control unit when required.	

(2) Connections for SR A13 LF

If the RF amplifier is not installed, two changes should be made to the arrangement shown in fig. 32. Connect tuner RF to TR A13 antenna socket (C to E in fig. 32 instead of C to D as shown) and connect TR A13 to harness adapter (G to K in fig. 32 instead of G to H as shown). Connectors E-F and J-K in the above list are not required. All other connectors should be as shown in the above list and in fig. 32.

(3) Additional connectors in trucks 1-ton Austin K9

As these trucks are not fitted with 24V power take-off, separate batteries should be installed in them for use with radio equipment. Stow two 12V 75 Ah batteries in one of the carriers under the table. Connect

them in series and earth the negative terminal as instructed in the installation handbook. Connect the LT box to the batteries by means of the cable assembly twin 6-ft. 6-in. long, which fits battery lugs, instead of the connector at 'T' in fig. 32 or 34, which has loop ends to fit 2 BA terminals.

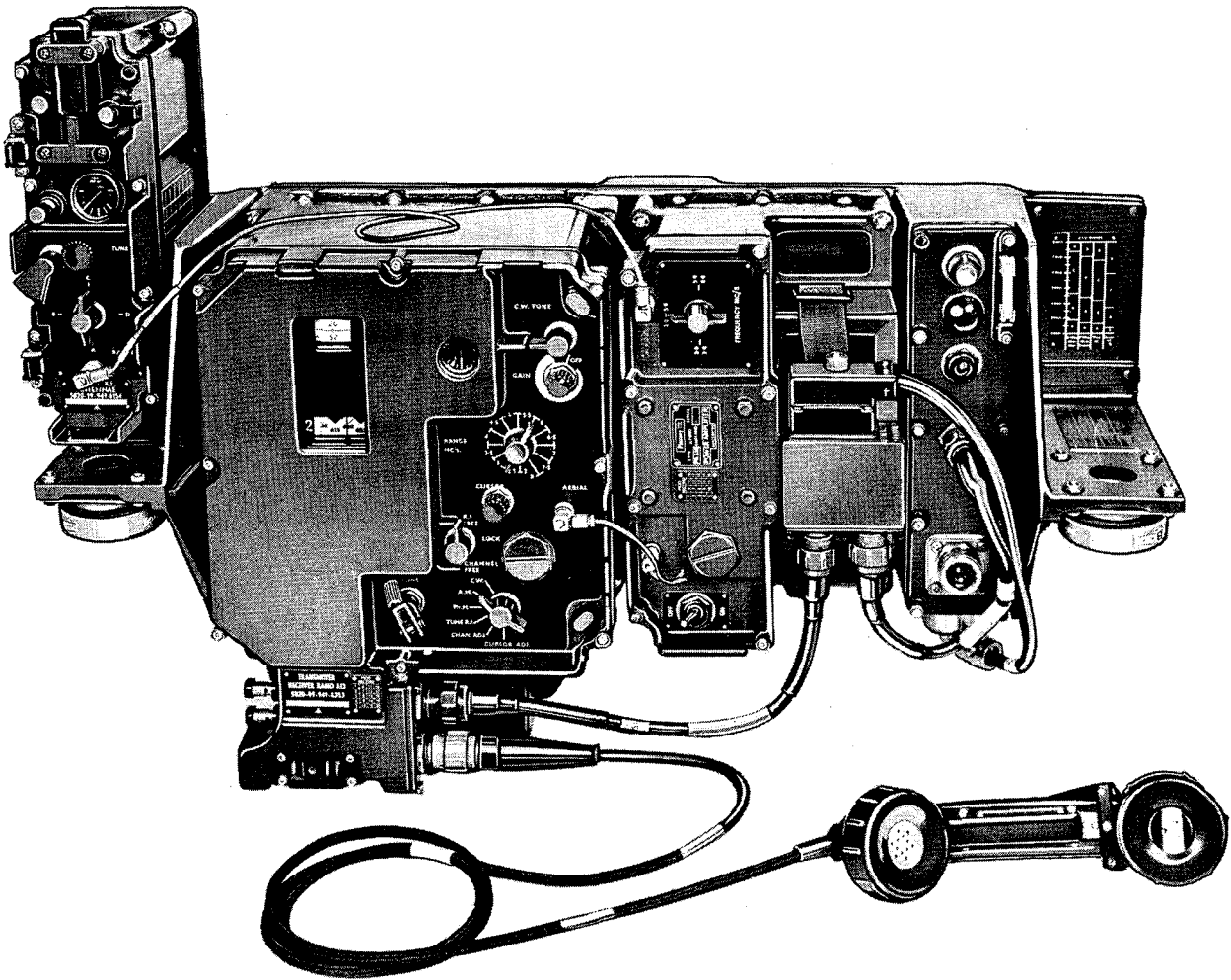

**FIG. 33 HARNESS ADAPTER WITH SR A13 AND Mk. 2 AMPLIFIER**

Section 35 CONNECTORS FOR SR A13 HP with MK 2 AMPLIFIER

If the Mk 2 amplifier is to be installed instead of the Mk 1 amplifier, one additional connector is required. This is connector W - X in fig. 34. It is a cable assembly 2-conductor, 14-in. and is obtained from kit no. 11. See page 55. All other connectors are the same as those listed on page 65.

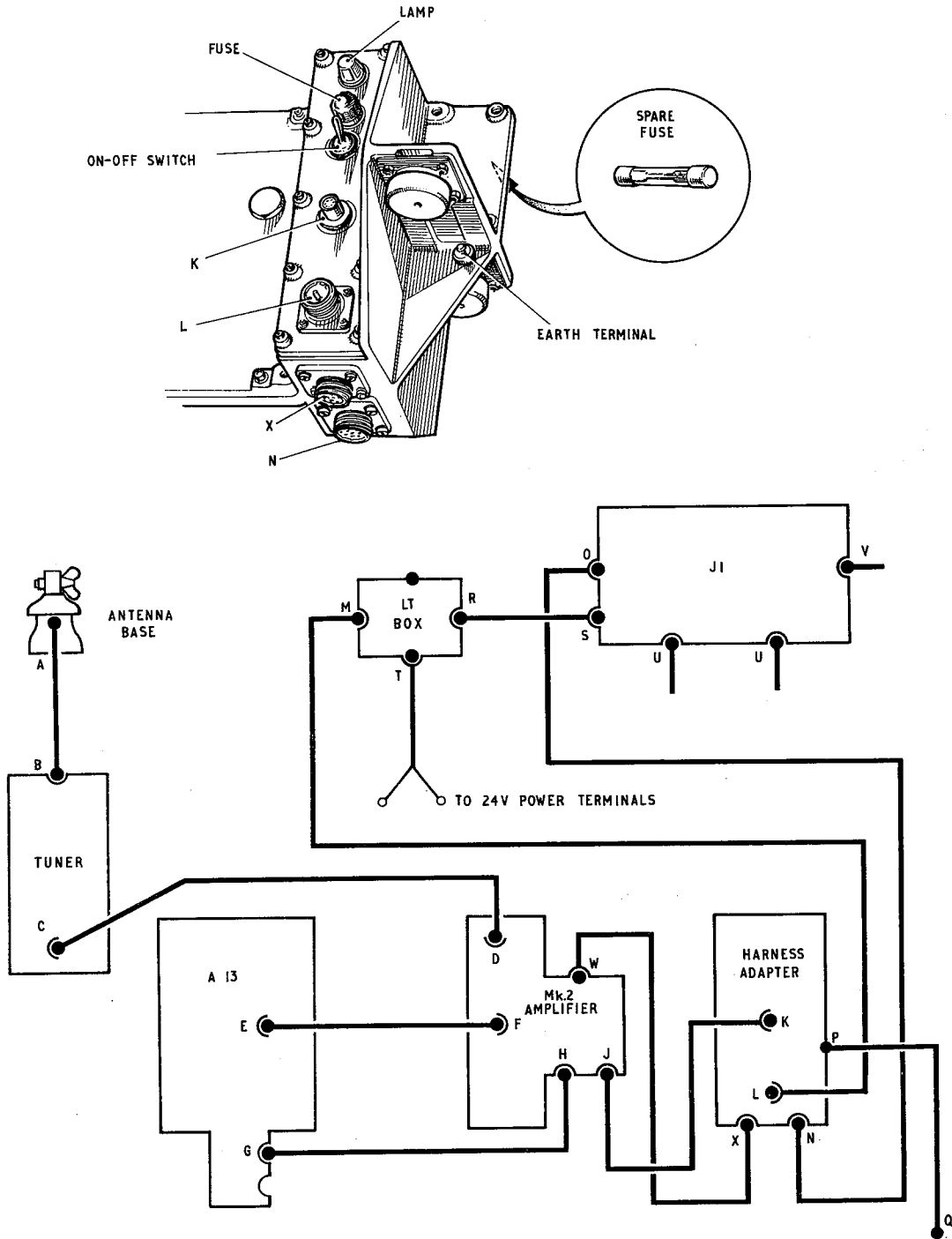

FIG. 34 CONNECTOR DIAGRAM-Mk. 2 AMPLIFIER

## Section 37 STABILISER VOLTAGE

### (1) Purpose

The battery was taken out when the TR A13 was fitted on the harness adapter and the stabiliser should be used to keep it charged. Where an RF amplifier is included in the station, two stabilisers should be used, one for each battery. If there is no radio set at the right hand end of the table and space is available on the slotted angle framework at that end, fit the stabilisers as in paragraph 2 below. If the stabilisers cannot be fitted on the framework, fit them to the table as in paragraph 3 opposite. Connections are the same whether the stabilisers are fitted on the framework or on the table. The stabiliser is supplied in kit No. 3. Two brackets are supplied in the kit on page 56.

### (2) Fitting stabilisers on the framework

Bolt the bracket to the framework using four screws, nuts and washers supplied with it. Fit the battery into the stabiliser and fasten the securing strap. Fit the stabiliser into the bracket and fasten the strap. See fig. 35. If two stabilisers are to be fitted, install them both in the same way.

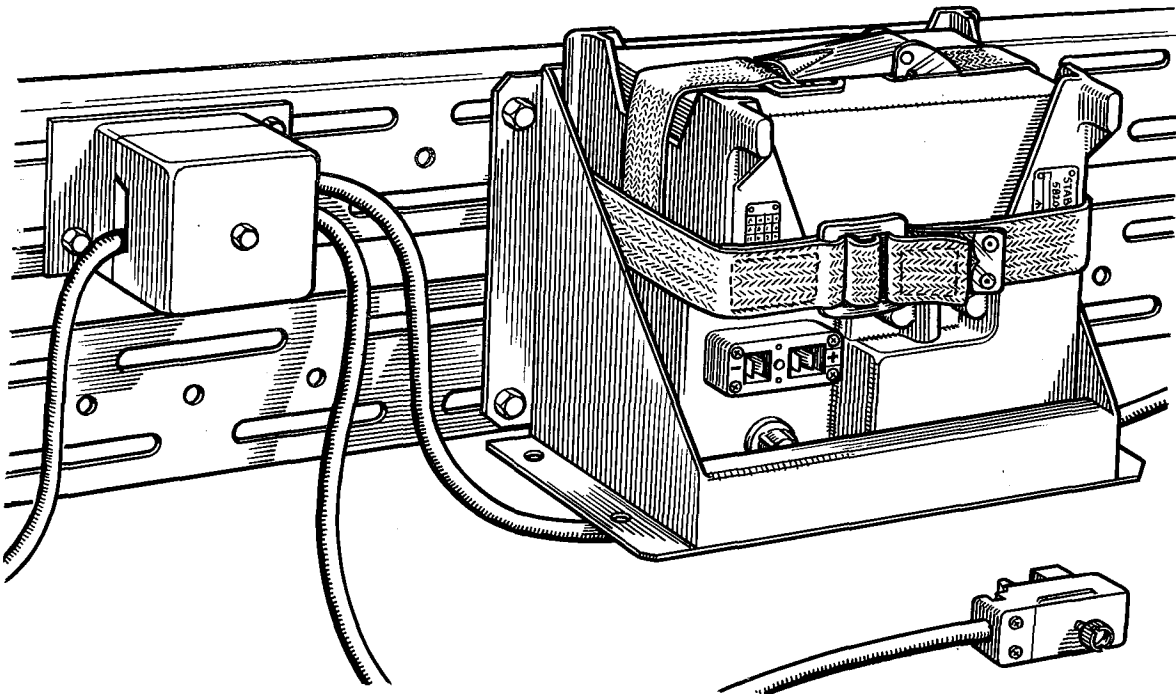

**FIG. 35 STABILISER MOUNTED ON FRAMEWORK**



(3) Fitting stabilisers on the table

When the stabilisers are to be fitted on the table, drill two sets of four holes as shown in fig. 28. Note that fig. 28 shows alternative positions for the two brackets. Position the stabiliser bracket on the table with its back against the back of the harness adapter. Line up four holes in the base flange with four holes drilled in the table. Bolt the base of the bracket to the table using four screws, nuts and washers supplied with it. Fit the stabiliser containing a battery into the bracket and fasten the strap. Fit the second stabiliser in the same way.

(4) Fitting the batten terminal

A batten terminal 2-pt. No. 4 and a plate on which it is mounted are supplied in the kit on page 56. Bolt the batten to the plate by means of two No. 2 BA screws, nuts and washers. Bolt the plate to the slotted angle framework in a convenient position.

(5) Connections

Connect the batten terminals to the LT box as shown in fig. 36 using a cable assembly, 2-condr. 1-ft. 3-in. in length. Connect the stabilisers to the batten terminals as shown using cable assembly 2-condr. 7-ft. 9-in. These cables are supplied in the kit on page 56. Ensure correct polarity with all connections to the batten terminals and replace the cover on the batten.

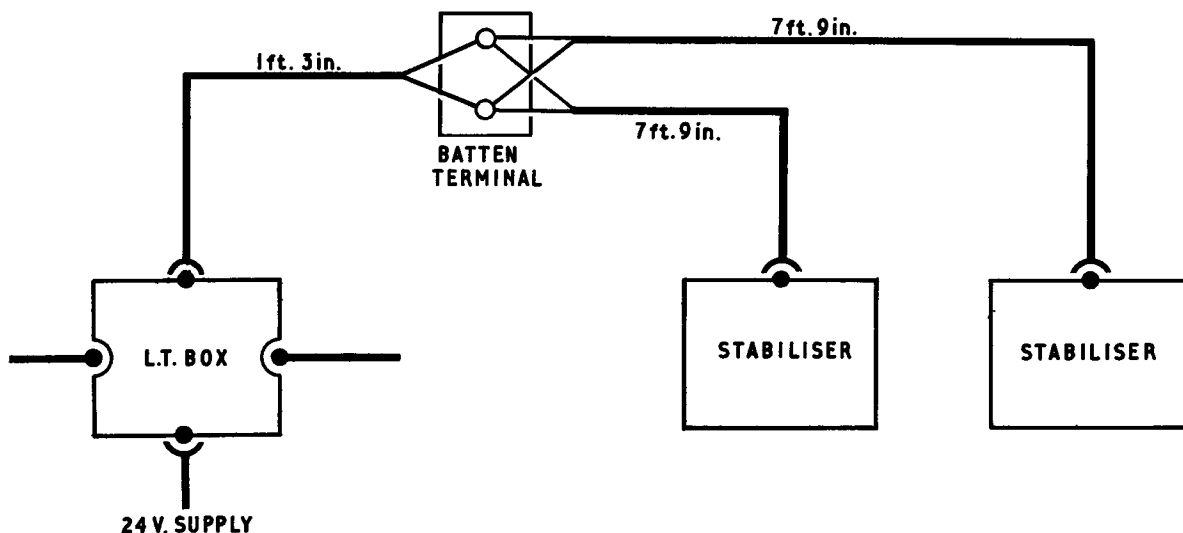

FIG. 36 CONNECTING THE STABILISER VIA THE LT BOX

## Section 38 OPERATING SR A13 WITH HARNESS ADAPTER

### (1) Power supply

In vehicle installations the harness adapter is connected to the 24V power supply terminals or, in vehicles without power terminals, direct to a 24V battery supply. In vehicles where there is a switch in this supply, for example the power distribution panel in trucks armoured 1-ton, switch the supply on.

### (2) ON - OFF switch

Switch the harness adapter ON when SR A13 is to be operated. The adapter has a lamp which lights when it is switched on.

### (3) Audio output

The harness adapter amplifies the receiver output to a level suitable for use with standard control harness units and headsets.

### (4) Remote control

Normal remote control facilities are available through the control harness, using up to half a mile of D10 cable connected to the J1.

### (5) Rebroadcast

When installed on the harness adapter the SR A13 or A13 HP can be used for manual rebroadcasting in conjunction with other radio sets. See part 4 of the installation handbook.

### (6) Fuse

A 10A fuse protects the harness adapter. A spare fuse is carried (see the inset to fig. 32). The correct replacement fuse to be used here is a Fuse link cartridge, 10A 250V.

## Section 39 STOWING UNUSED EQUIPMENT

### (1) Manpack carrying frames

- (a) When SR A13 is installed on the harness adapter the empty carrying frames can be stowed on the truck between the front seats. To secure them there a web strap 4-ft. 2 $\frac{1}{4}$ -in. long and two 1/4 UNF screws are supplied.
- (b) To fasten the strap in position, make a small hole 18-in. from the buckle end. Position this point over an existing hole in one of the brackets against which the jerrican rests. Clamp the strap between a flat washer and the metal bracket. Fit a spring washer under the bracket and bolt the strap down.
- (c) Draw the strap across to the second similar bracket and fasten in there with the second bolt.
- (d) Position the carriers against the bulkhead, or against the jerrican if it is fitted, and strap them down.

(2) Hand generator

- (a) The hand generator should be stowed on the slotted angle framework, the most convenient position being at the extreme left hand end. Before stowing the generator, close the handle and clamp it.
- (b) In the interests of safety the large mounting screw should be removed from the end of the generator when it is stowed on the framework.
- (c) A steel bar 6-in. x  $1\frac{1}{2}$ -in. and a screw clamp are provided to secure the generator to the framework. Bolt the bar to the front of the upper slots on the lower rail. Bolt the clamp to the top rail over it. See fig. 37.
- (d) To stow the generator, hook the feet over the bar, engage the lug under the screw clamp and tighten it down. See fig. 37.
- (e) The hand generator is not intended to be used in this position. It should not be required while TR A13 and the RF amplifier are installed on the harness adapter.

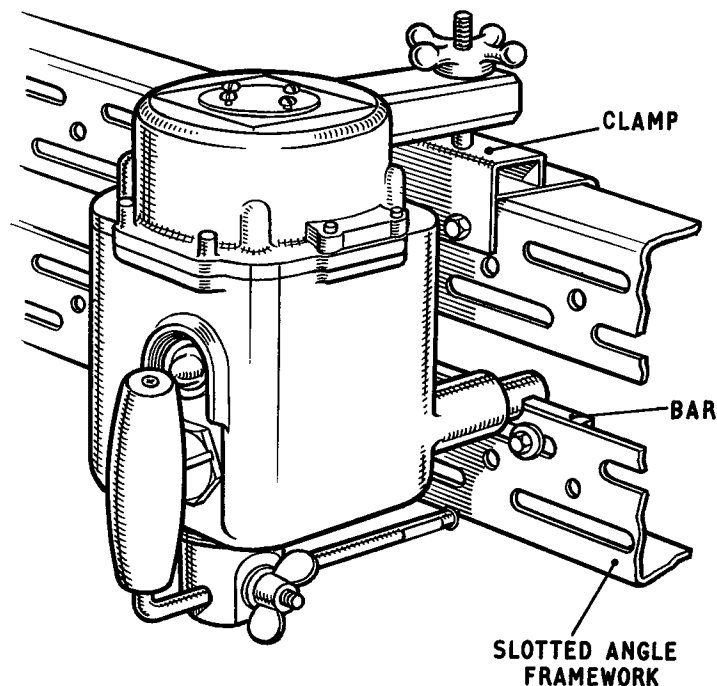

**FIG. 37 HAND GENERATOR STOWED ON FRAMEWORK**

Section 40 USING THE CLIP-ON KIT

This installation kit is referred to as the 'Clip-on' kit to distinguish it from the harness adapter kit.

(1) Temporary installation in any FFR truck

The SR A13 LP or HP manpack radio station can be installed on the table or on the slotted angle framework in an FFR truck by means of a separate installation kit. This kit consists of a mounting board and component parts of a vehicle antenna, etc. See page 73. In such an arrangement the SR A13 is operated as it would be in a manpack role and it is powered by its internal battery or batteries but it uses a vehicle type antenna rod.

(2) Temporary installation in truck cargo 1/4-ton and 3/4 ton Rover

Whenever possible the FFR version of the 1/4-ton or 3/4-ton Rover should be used as it is equipped with the necessary furniture and the SR A13 can be installed with the aid of the kit on page 73. It also has 24V power take-off which can be used to charge the TR A13 and RF amplifier internal batteries through the stabiliser.

If an FFR Rover is not available for the installation a cargo Rover can be used but as it contains no furniture the user will first have to fit the kit of furniture on page 76. This kit equips the cargo Rover with the slotted angle framework and antenna brackets as in FFR trucks.

In an emergency, if the SR A13 has to be installed in a cargo Rover and this kit of furniture is not available, the table and the antenna bracket from an FFR Rover can be transferred to the cargo Rover. The cargo truck was pre-drilled in manufacture ready for the furniture from an FFR vehicle, or for the furniture supplied in the kit on page 76, to be fitted by the user.

After the kit on page 76 has been fitted, the kit on page 73 can be used to install the SR A13 manpack radio station. See pages 77 and 78 for the installation in the cargo truck.

NOTE - Cargo type Rover trucks do not have power take-off terminals and may have a 12V lighting system, in which case the A13 batteries cannot be charged through the stabiliser as shown in fig. 25.

Section 41 CONTENTS OF THE 'CLIP-ON' KIT

The 'clip-on' kit is designated: Installation kit, electronic equipment, SR A13 in Rover Mk. 8 and 9 (Z1/5820-99-103-7601). For details see the latest issue of the relevant CES. The 'clip-on' kit contains the following items:

Description	Remarks
Antenna element, 49 $\frac{1}{2}$ -in.	Bottom section of 12-ft. antenna
" " "	Centre section of 12-ft. antenna
" " "	Top section of 12-ft. antenna
Base antenna support (5820-99-949-3482)	
Bracket stabiliser, 8.3/4 x 4.7/32 x 6.7/8-in. (5820-99-103-6926) (two)	To mount stabilisers on the slotted angle framework. See fig. 35
Bushing rubber (5340-99-103-4883)	Used on antenna lead
Cable assembly 2-condr., 7-ft.9-in. (5995-99-103-6905)	Connects stabiliser to batten terminal. See fig. 36.
Cable electric 1-condr.44/0.012. (Y1/6145-99-900-7962)	Antenna lead. See fig. 30.
Case antenna (5985-99-949-1061)	
Clamp antenna base (5820-99-949-3038)	To secure antenna base to mounting
Insulators bowl (50) (5970-99-103-5758)	Insulators on antenna lead
Nut gland and washer (ZA 50365)	Connects antenna lead to base
Plate plastic (ZA 50358)	Fitted under the antenna base
Plug and nut assembly (5820-99-103-6908)	Connects lug on antenna lead to tuner RF WHIP socket.
Spanner wrench (5120-99-103-5591)	To screw nut gland into base antenna.
Stiffener, wood, 32 $\frac{1}{2}$ x 7-in. (5820-99-103-6944)	To strengthen slotted angle framework when A13 is mounted on it.
Support transmitter radio wood (5820-99-103-6810)	Mounting board for A13 manpack carrier. See fig. 38.
Terminal set, quick disconnect (5940-99-103-5577)	Lug to fit at tuner end of antenna lead.

## Section 42 FITTING THE CLIP-ON KIT IN AN FFR TRUCK

### (1) Existing furniture

Fig. 39 on page 77 shows the furniture provided in an FFR Rover. It includes table, slotted angle framework, terminal batten for 24V power supply and two antenna mountings.

### (2) Drilling the table

SR A13 should be fitted at the left hand end of the table except when this position is already in use. See page 54, paragraph 3. To mark the positions for the fixing holes, position the support transmitter radio wood on the table as shown in fig. 38. At the left hand end, line up two holes in the support board with two existing holes in the table. At the right hand end of the support board, mark the positions of the two remaining holes and drill them 5/16 in. dia.

### (3) Fitting the support transmitter radio wood

Bolt the support board to the table as shown in fig. 38 using four screws, nuts and washers supplied with it.

### (4) Fitting the A13 manpack station

SR A13 equipment should already be mounted on the manpack frame. Secure the manpack frame to the support board by means of the two hinged clamps and the web strap. Tighten it firmly.

### (5) Making the antenna lead

Make an antenna lead as shown on page 62. A plug and nut assembly is supplied in the kit on page 73 to connect the lug on this antenna lead to the antenna socket on the tuner RF.

### (6) Fitting the antenna base

Use the antenna mounting adjacent to the position chosen for the SR A13. Fit the HF antenna base to the mounting as shown on pages 62 and 63.

### (7) Fitting the stabiliser

- (a) When the stabiliser is required in the installation, bolt the bracket to the slotted angle framework. Four screws, nuts and washers are supplied with it. Fig. 35 on page 68 shows it fitted.
- (b) Fit the stabiliser into the bracket and secure the web retaining strap.
- (c) Fit the 7-ft. 9-in. cable between the stabiliser and the 24V power supply terminals. In FFR Rover trucks use the 24V terminals marked EQUIPMENT on the inside wall near the left hand end of the table. Refit the cover over the terminals with care.

- (d) For SR A13 HP two stabilisers can be installed, one for the A13 and the other for the RF amplifier. Fit the second one in the same way and connect it to the same 24V EQUIPMENT terminals. See paragraph 7(c) opposite.

IMPORTANT - Ensure correct polarity with the '+' (red) and '-' (black) connections

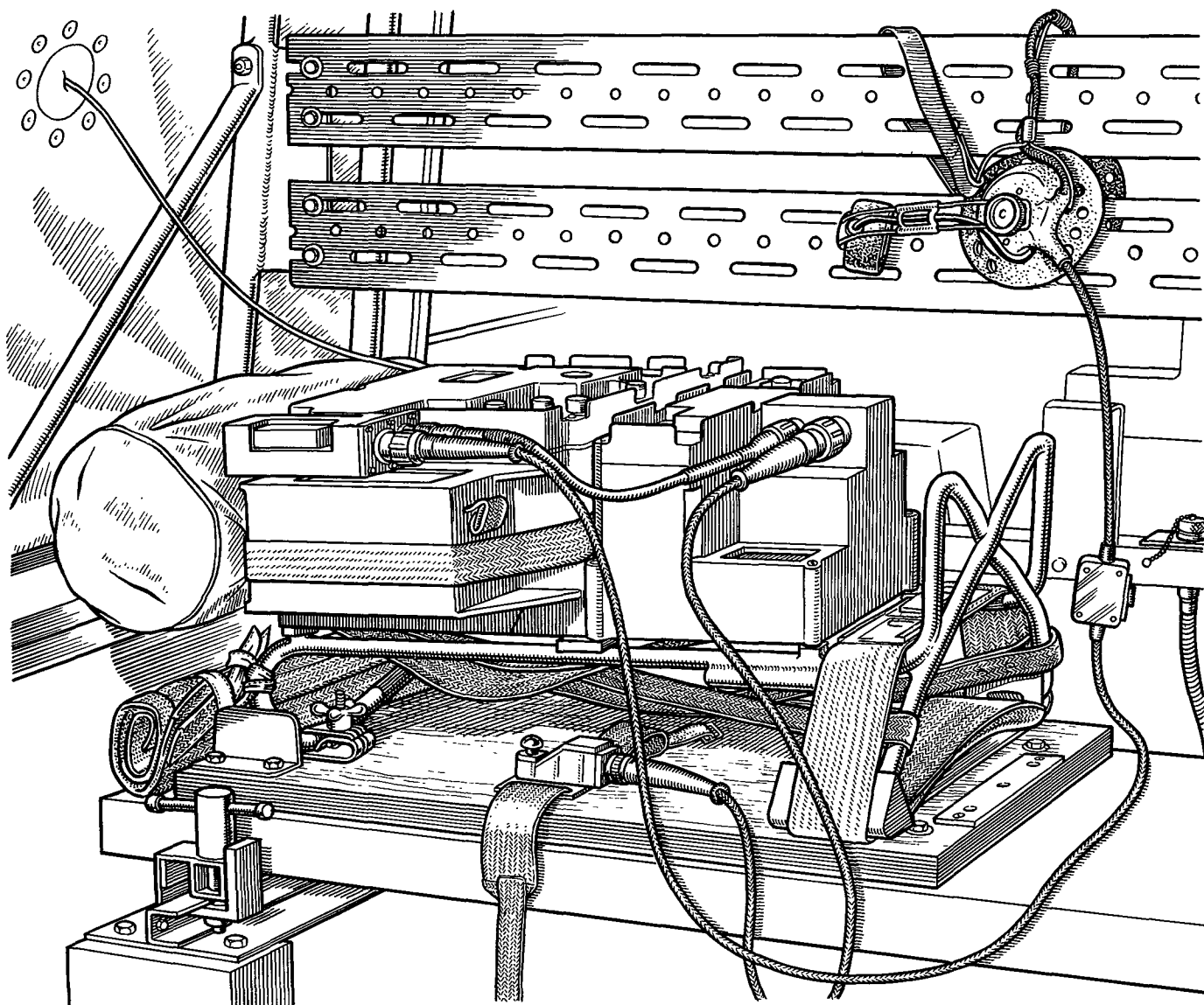

FIG. 38 SR A13 HP WITH CLIP-ON KIT IN AN FFR TRUCK

Section 43 FRAMEWORK AND ANTENNA BRACKET KIT FOR A ROVER CARGO TRUCK

This kit contains antenna bracket, slotted angle framework, etc., to enable the A13 'clip-on' kit to be fitted into a cargo version of Rover Mk. 8 or 9. It is designated: Installation kit electronic equipment SR A13 in Rover Mk. 8 and 9 cargo (Z1/5820-99-103-9317)

Description	Remarks	Fig.
Angles perforated (two) (LV7/RU/334788) Grommets (two) (LV7/RU/273527) Plate tie (LV7/RU/334898) Stays rack (two) (LV7/RU/334785) Tube support left hand (LV7/RU/339467) Tube support right hand (LV7/RU/339466)	Component parts of slotted angle framework	39
Screws UNF, 1/4 x 3/4 (12) with nuts, flat and spring washers	To bolt the framework together	
Screws UNF, 5/16 x 7/8 (six) with flat and spring washers	To bolt the framework to the truck	
Bracket antenna support, 7.3/4 x 4 x 3.1/4-in. (5985-99-949-3507)	Bolted to side of truck	39
Bolts UNF, 1/4 x 7/8 (two) with flat and spring washers	To secure bracket antenna support	37
Bolts UNF, 1/4 x 1 (two) with nuts, flat and spring washers	Fitted to bracket as mounting for antenna base	39
Base antenna element, 21-in. l ng (5985-99-103-6155)	To strengthen the slotted angle framework when the SR A13 assembly is mounted on it.	39
Stiffener wood, 32 <sup>1</sup> / <sub>2</sub> x 7-in. x 22 mm. (5820-99-103-6944)	To bolt the stiffener to the slotted angle framework.	40
Bolts UNF, 1/4 x 1.3/4 (two)	To bolt the stiffener to the slotted angle framework.	40



Section 44 FITTING THE FRAMEWORK AND ANTENNA BRACKET KIT

(1) Fitting the angle framework

Assemble the slotted angle framework as shown in fig. 39, using the component parts and the  $1/4 \times 3/4$ -in. screws, nuts and washers supplied in the kit on page 76. Bolt it to the top of the side walls using three  $5/16$ -in. screws, nuts and washers on each side. Insert a rubber grommet into the top of each vertical tube.

(2) Fitting the plywood stiffener

This board is drilled with eight fixing holes and supplied with screws, nuts, lock nuts and washers. It is to be fitted against the front or inside of the slotted angle framework to strengthen it. Position it approximately half an inch clear of the mounting at the left hand end of the angles. Bolt it to the angles by means of two screws fitted slightly to right of centre, through the narrow part of the board, but do not tighten the screws until the support board which carries the SR A13 manpack frame has been located on the slotted angle framework. See paragraph 1 on page 78.

(3) Fitting the bracket antenna support to the side of the truck

The antenna is to be fitted on the side adjacent to the tuner RF. Bolt this bracket to existing tapped holes using two bolts  $1/4 \times 7/8$ -in. and two  $1/4 \times 1$ -in. all with flat washers and spring washers under the heads. Fig. 39 shows this bracket fitted. Fit the vertical tube into the socket on the bracket antenna support and make it fast by means of the screw in the base.

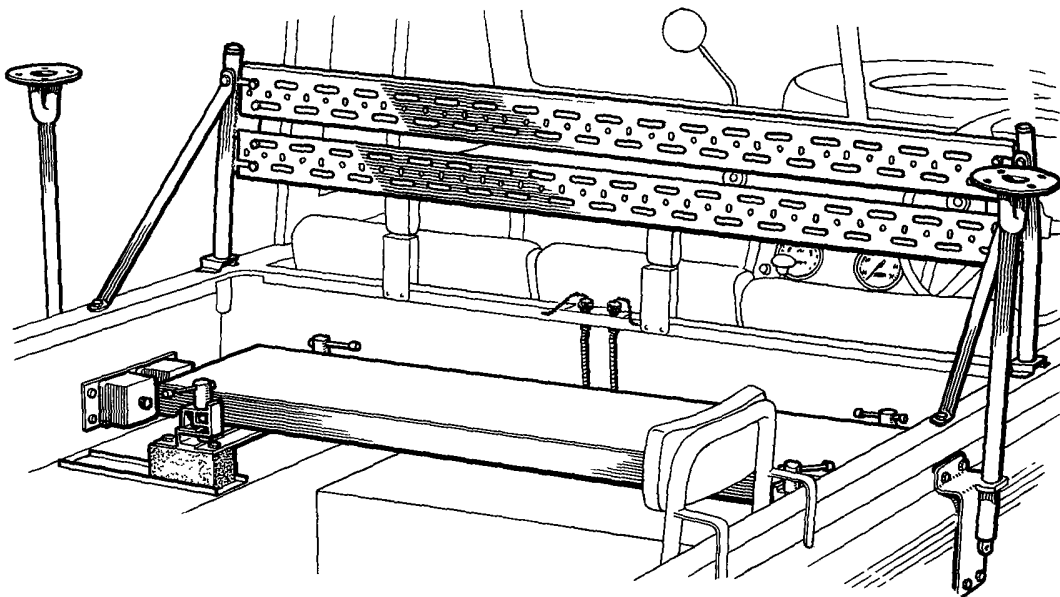

**FIG. 39 ANGLE FRAMEWORK AND ANTENNA BRACKET**

Section 45 FITTING THE CLIP-ON KIT ON THE FRAMEWORK

(1) Fitting the support transmitter radio wood

Position this support board against the rear of the slotted angle framework as shown in fig. 40. Fit six screws through it, through the framework and through the plywood stiffener. Fit washers, nuts and lock nuts and tighten down. Finally tighten the two screws fitted in paragraph 2 on page 77.

(2) Fitting the A13 manpack station

The SR A13 equipment should already be mounted on the carrying frame. Fit the frame to the support board as shown in fig. 40 and secure it by means of the two hinged clamps and the web strap. Tighten it firmly.

(3) Antenna

Fit the antenna base and cable as on pages 62 and 63.

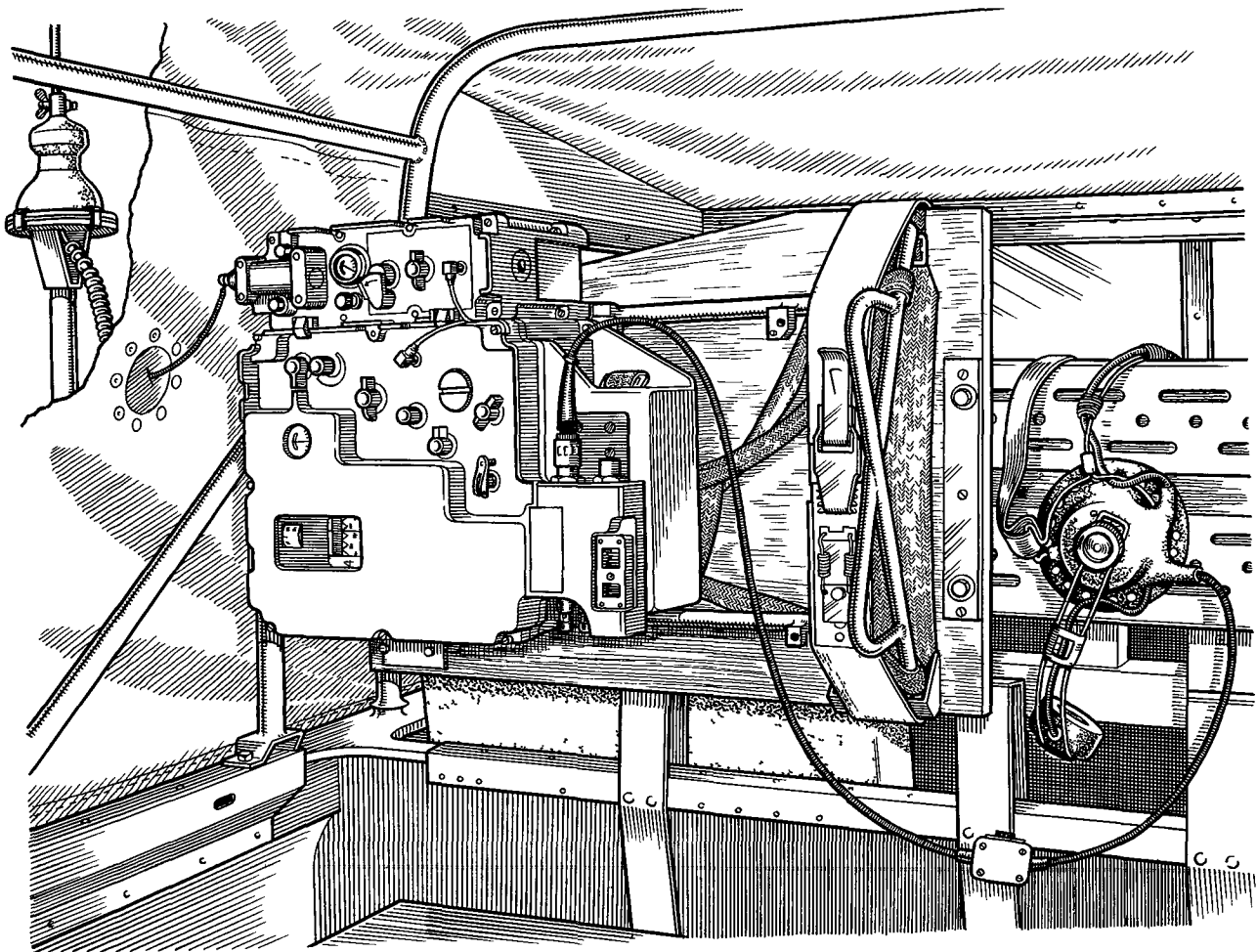

**FIG. 40 SR A13 LP WITH CLIP-ON KIT IN MODIFIED CARGO TRUCK**

# CHAPTER 5

## SERVICING

### Section 46 SERVICING TASKS

- (1) No equipment can be expected to work properly unless it is kept in first class condition by regular servicing, conscientiously carried out. This is the responsibility of the NCO or man who is in direct charge of the equipment and NOT of workshop or repair staffs, though workshop personnel may be called upon to carry out certain servicing tasks.
- (2) To guide the NCO or man responsible for servicing, and to ensure that it is carried out regularly, Signal equipment is serviced on a task system.
- (3) Operator's servicing tasks for SR A13 are very simple and few in number. They are detailed in section 47.
- (4) Instructions regarding supervision of servicing, frequency of carrying out tasks and recording of completion of tasks will be issued by Unit Commanders. Army Form B2661 can be used for recording purposes.
- (5) TR A13, tuner RF and amplifier RF are contained in die-cast metal cases. These cases are fully sealed and must not be opened except in workshops.

### Section 47 OPERATOR'S SERVICING

- (1) Keep the equipment clean and dry. Remove any dirt from plugs and sockets, dials and control knobs.
- (2) Check all switches and controls to ensure that they are working correctly.
- (3) Examine all connectors for frayed ends or damaged insulation. Pay particular attention to the coaxial connectors. If any connectors appear to be faulty, report this to the appropriate technician.

### Section 48 TECHNICIAN'S SERVICING

The following charts present a systematic method of checking the performance of SR A13. If the equipment satisfies the following tests then it is reasonably certain to be in good working order. If the equipment is faulty, then the tests will indicate in which unit the fault lies.

Test No. 1

TR A13 WITH BATTERY, HANDSET, HEADGEAR, TUNER RF AND 8-FT. ANTENNA

Connect SR A13 and switch on.  
 Turn TR A13 system switch to Ph.M.  
 Operate and release the pressel switch.

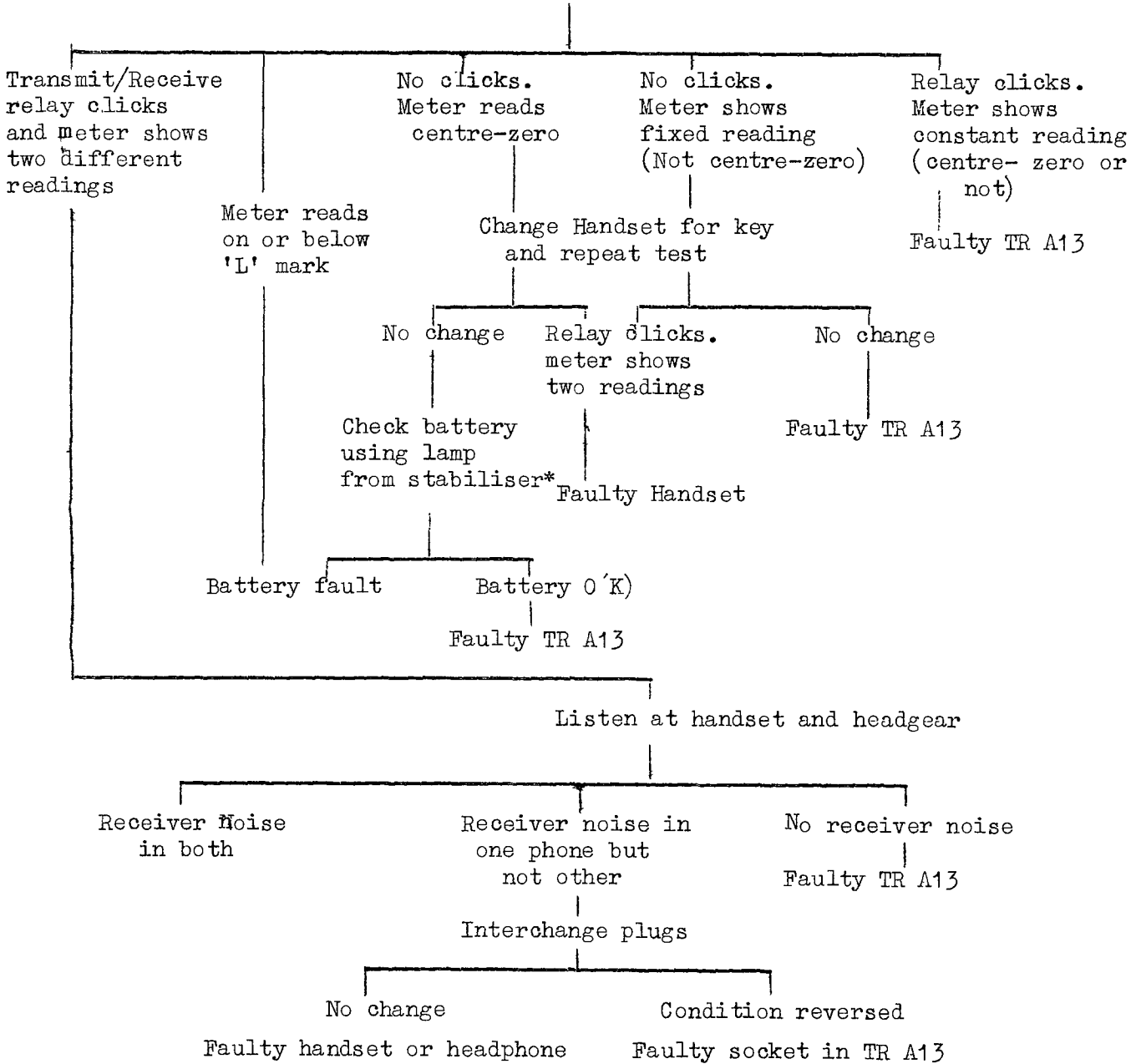

Test No. 1 continued on next page

\* See note opposite

Test No. 1 (continued)

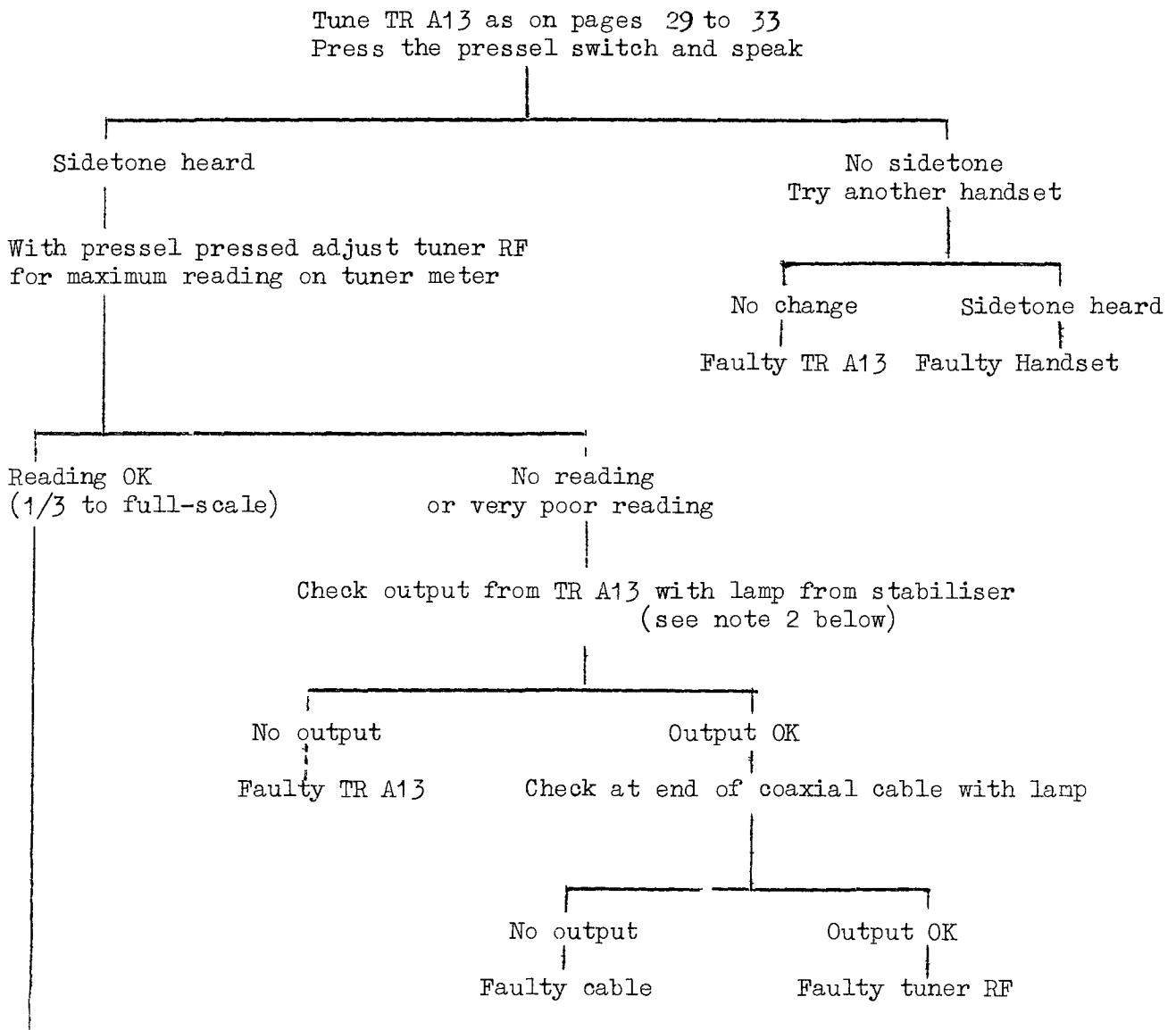

Proceed to next test.

Note 1 - To remove the lamp from the stabiliser, first remove the lamp cover by unscrewing it at the black base ring. The 12V lamp can then be slipped out of the cover. The red cover is a dimming device and revolves freely.

Note 2 - To check TR A13 output, insert a short piece of wire into the coaxial centre socket and hold the lamp contacts between this and the coaxial outer ring. Press the pressel. The lamp should light.

Test No. 2

Exchange handset for key

While listening on single headgear, switch from RT to CW.

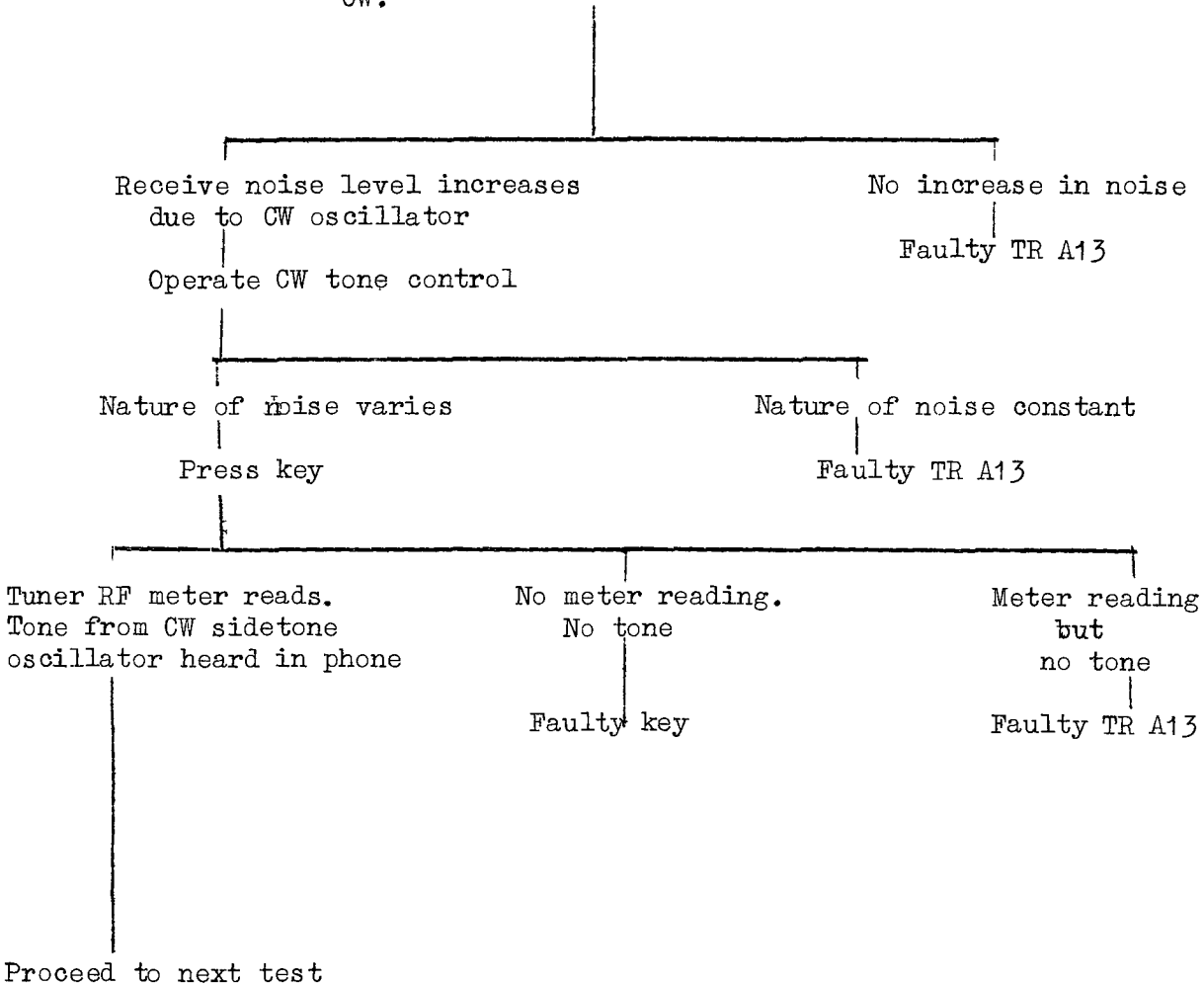

Test No. 3

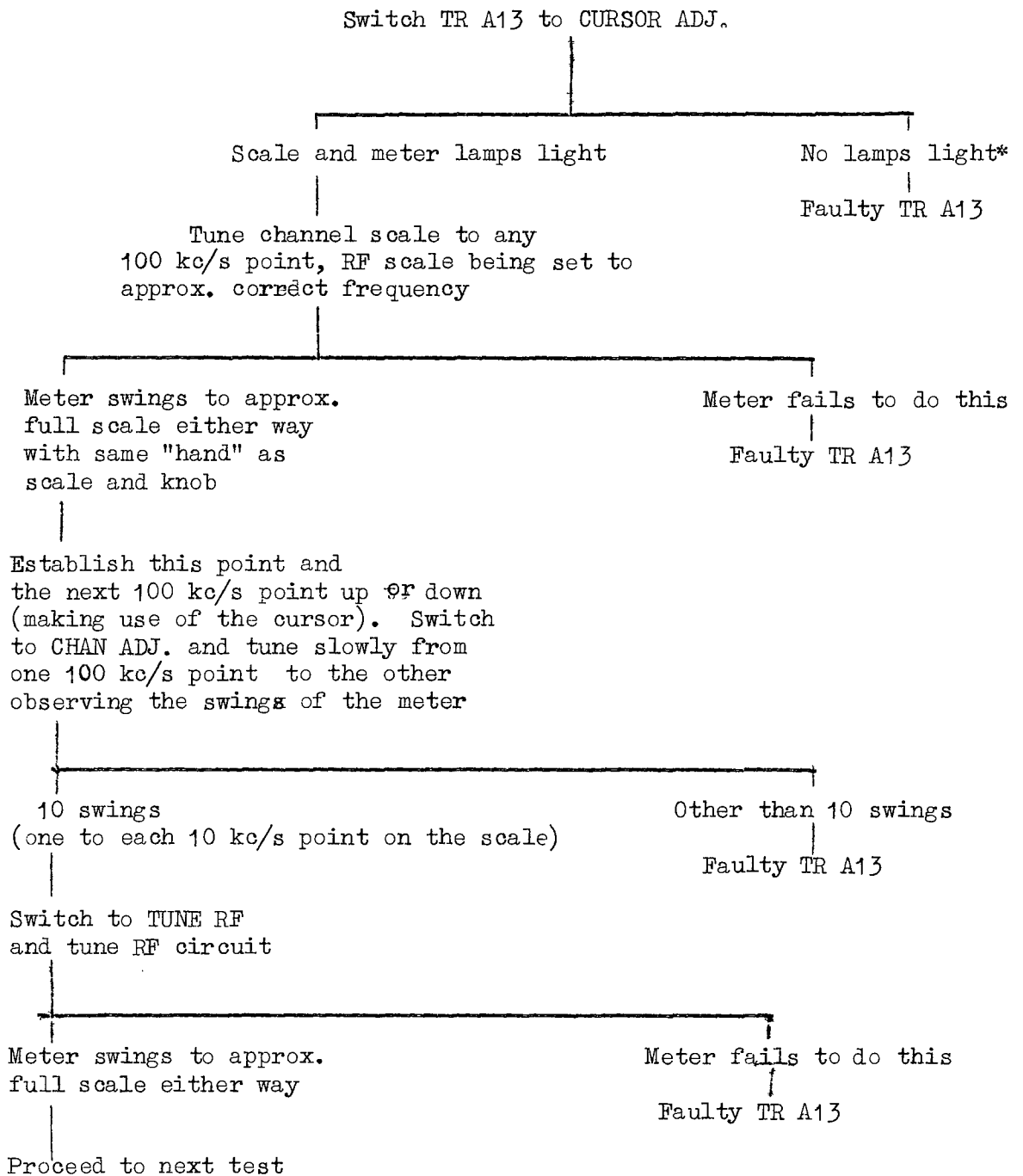

\*Note - In bright sunlight shield windows when checking scale lamps

Test No. 4

Mk. 1 AMPLIFIER

Testing Mk. 1 amplifier in addition to units already tested

Connect Mk. 1 RF amplifier to TR A13  
Connect handset  
Fit 8-ft. whip antenna to tuner.  
Connect tuner RF to amplifier RF

Switch ON  
Switch TR A13 to Ph.M.  
Switch RF amplifier to TUNE PA.  
Turn RF amplifier frequency switch to  
appropriate band

Operate TUNE control on RF amplifier

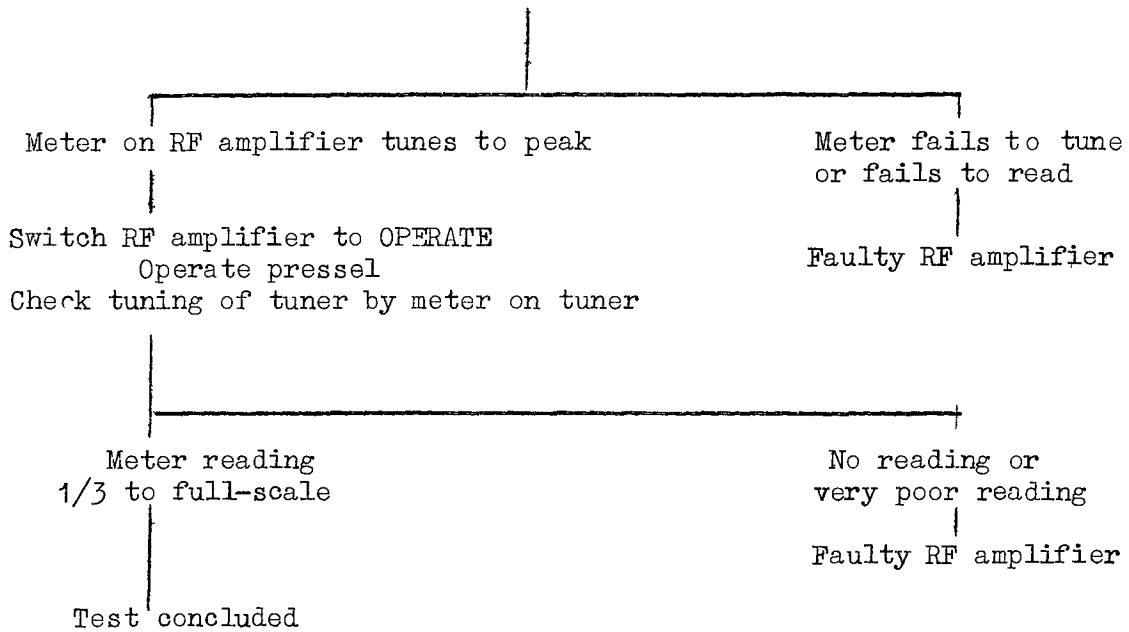



Test No. 4

MK 2 AMPLIFIER

Testing Mk 2 RF amplifier in addition to units already tested

Connect Mk 2 amplifier to TR A13  
Connect amplifier output to input of tuner RF  
Fit 8-ft. whip antenna to tuner RF  
Connect handset

Switch TR A13 on.  
Switch TR A13 to Ph.M.  
Adjust tuner RF.  
Turn amplifier frequency switch to appropriate band.

Switch RF amplifier on.  
Observe meter on tuner RF

Operate

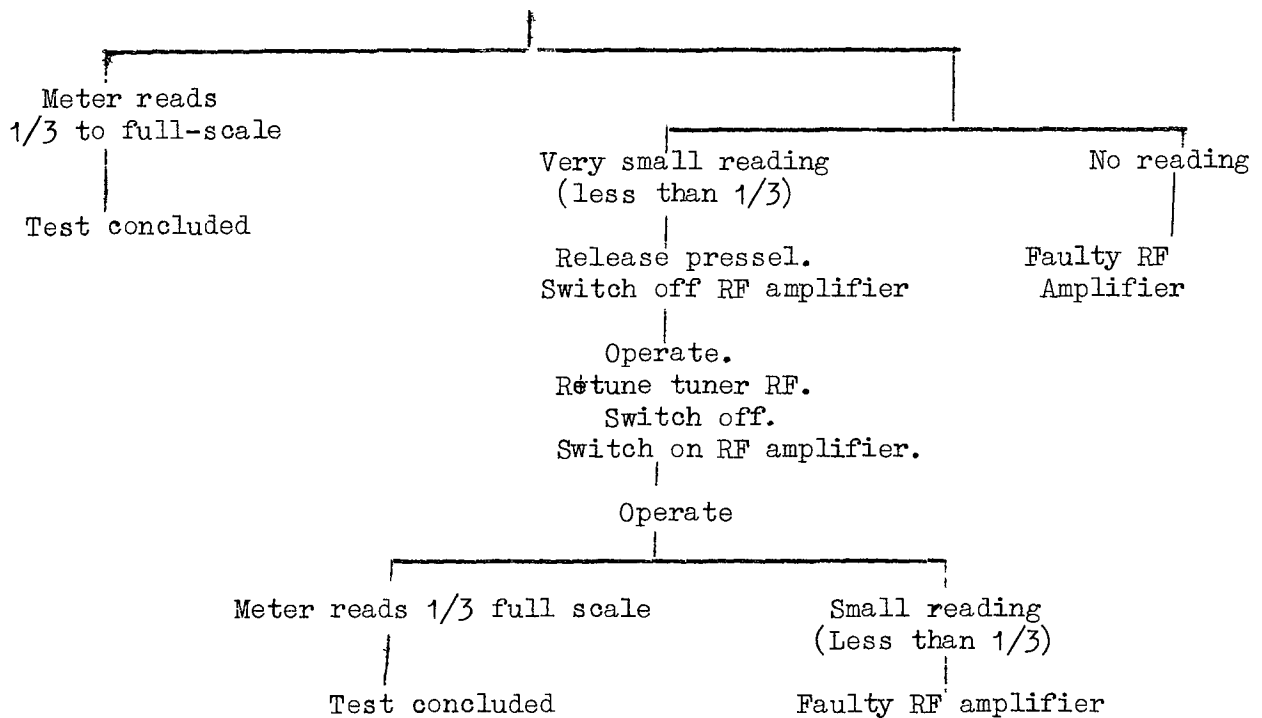

REMINDER

EXTERNAL POWER SUPPLY CONNECTIONS

Connect 24V d.c.

- (1) To the stabiliser for battery charging (fig. 25)
- (2) To the Mk 2 amplifier when using external batteries (fig. 24).
- (3) To the Mk 2 amplifier on the harness adapter
- (4) To the harness adapter ('L' in fig. 34)
- (5) To the charger for central battery charging (see page 52)

Connect 12V d.c.

- (1) To TR A13 when using external batteries (fig. 24)
- (2) To the Mk 2 amplifier as alternative to (2) above. See page 45.

DO NOT CONNECT 24V  
TO TR A13