

RESTRICTED

AIR PUBLICATION

2535E

VOLUME I

ARI. 5874

**GENERAL AND TECHNICAL
INFORMATION**

Prepared by direction of
the Minister of Supply

J. R. C. Helmer

Promulgated by Order
of the Air Council

J. H. Barwell

AIR MINISTRY

CONTENTS

PRELIMINARIES

Amendment record sheet

Ejection seat warning

Lethal warning

Note to readers

Layout of A.P.



PART 1—LEADING PARTICULARS AND GENERAL INFORMATION

SECTION 1—Airborne h.f. radio communication equipment

- Chap. 1 *Introduction and general description*
- 2 *Receiver Type R.4187*
- 3 *Control unit Type 4190*
- 4 *Transmitter Type T.4188*
- 5 *Power and radio unit Type 4192*
- 6 *Control unit (remote) Type 4189 and junction box Type 4191*
- 7 *Remote control and switching system*
- 8 *Voltage regulator (5UC/6010)*
- 9 *Amplifying unit Type 7435 (speech clipping modulator fitted to power and radio unit)*
- 10 *Racking system, back plates and installation details*

SECTION 2—Suppressed aerial systems

- Chap. 1 *Introduction to suppressed aerial systems for ARI.5874*
- 2 *Selector unit Type 7003*
- ◀3 *(Cancelled)*
- 4 *(Cancelled)*
- 5 *(Cancelled)*▶
- 6 *Tuning unit (aerial) Type 7016*
- 7 *Impedance matching units Type 7949, 7949A, and 9541*
- 8 *Control unit Type 7216*
- ◀9 *(Cancelled)*▶
- 10 *Suppressed aerial installation (ARI.5874)*
- ◀11 *(Cancelled)*▶
- 12 *Circuit description of aerial system Type 9502*
- 13 *Setting up and operation of ARI.5874 with aerial system Type 9502*
- 14 *Suppressed aerial installation using aerial system Type 9502*

SECTION 3—Fixed wire aerial systems

- Chap. 1 *Aerial tuning unit Type 7180*
- 2 *Control unit Type 4243*
- 3 *Fixed aerial installation (ARI.5874)*
- 4 *Setting up and operation of ARI.5874 with fixed wire aerial systems*

RESTRICTED

SECTION 4—Anti-static aerial equipment

- Chap. 1 Introduction to anti-static aerial equipment*
- 2 Mast, aerial Type 69*
- 3 Tension unit, aerial, aft (10B/16897)*
- 4 Mast, aerial Type 67*
- 5 Mast, aerial Type 68*
- 6 Tension unit, aerial forward (10B/16899) and tension unit, aerial, aft (10B/16898)*

PART 2—TECHNICAL INFORMATION (Servicing)

- Chap. 1 Test bench rig and test equipment requirements*
- 2 General servicing of receiver-transmitter equipment*
- 3 General servicing of suppressed aerial equipment*
- 4 General servicing of fixed aerial equipment*
- 5 Special test equipment*

PART 3—FAULT DIAGNOSIS

- Chap. 1 Fault location on h.f. receiver, transmitter and fixed aerial tuning unit.*

RESTRICTED

LEADING PARTICULARS

Purpose of Equipment

Airborne general purpose h.f. communication equipment using suppressed or open-wire aerial system. The transmitter and receiver are crystal-controlled and channel selection is from remote control using a self-balancing resistance bridge system (Wheatstone servo). The maximum power requirement at 28 volts is 1135 watts.

TRANSMITTER

<i>Frequency range</i>	2.8 to 18.1 Mc/s. Covered in two bands: Band 1 2.8 to 7.0 Mc/s Band 2 7.0 to 18.1 Mc/s
<i>No. of channels</i>	24 preset channels in any part of the band and in any order. ◀▶
<i>Type of crystals</i>	ZDH type; 2.8 to 18.1 Mc/s fundamental frequency throughout.
<i>Frequency stability</i>	±0.01 per cent or 1 kc/s whichever is the greater.
<i>Service</i>	CW, MCW, or R/T.
<i>Output power</i>	100 watts minimum carrier power on CW, MCW and R/T (measured into 70-ohm non-reactive load).
<i>R/T operation:</i>				
<i>Modulation</i>	Full anode and screen modulation with V.O.G.A.D. and "speech clipping" incorporated.
<i>Distortion</i>	Not more than 15 per cent over a range of 500 to 3000 c/s.
<i>A.F. response</i>	Not less than -5 dB at 300 c/s; and ± 1 dB at 3000 c/s relative to 1000 c/s.
<i>Carrier noise level</i>	Not less than -50 dB below level given by 100 per cent modulation
<i>M.C.W. operation</i>	The tone frequency in use is 1000 c/s ±15 per cent at a modulation depth of 95 to 100 per cent.
<i>C.W. operation</i>	Keying speed 30 bauds with less than 20 per cent dot shortening. Break-in working is possible at this speed.
<i>Average power consumption</i>	28 volts d.c. 19 volts d.c. Power input (amp) (amp) (watts at 28V)*
<i>Transmitting:</i>				
CW (mark)	20.0 6.1 750
MCW (mark)	26.5 6.1 910
R/T (normal speech)	23.5 6.1 830
<i>Standby</i>	1.3 6.1 210
<i>Altitude rating (unpressurized aircraft)</i>	30000 ft			

*Increased by 30 watts approx. when a channel is being selected.

RECEIVER

<i>Frequency range</i>	2.8 to 18.1 Mc/s covered in three bands: Band 1 2.8 to 5.2 Mc/s Band 2 5.2 to 9.7 Mc/s Band 3 9.7 to 18.1 Mc/s
<i>No. of channels</i>	24 preset channels (as transmitter).
<i>Type of crystal and frequencies</i>	ZDH type: Band 1 4.95 to 7.35 Mc/s Band 2 7.35 to 11.86 Mc/s Band 3 7.55 to 15.95 Mc/s
<i>Frequency stability</i>	0.01 per cent or ± 1.5 kc/s whichever is the greater.
<i>Service</i>	CW, MCW or R/T
<i>Fine tuning</i>	The fine tuning control will vary the received frequency ±7 kc/s.
<i>Audio output :</i>				
<i>R/T and M.C.W.</i>	150 mW into 50-ohms with 50 per cent modulation at 1000 c/s.
<i>C.W.</i>	150 mW into 50-ohms, beat note nominally 1000 c/s.
<i>Sensitivity</i>	(Note:—"Standard output" is not less than 60 mW into 50 ohms with a receiver input of 50 µV modulated to a depth of 50 per cent at 1000 c/s).
<i>R/T and M.C.W.</i>	Not more than 6 dB down on "standard" output will result from an input signal of 3 µV modulated 50 per cent.
<i>C.W.1 and C.W.2</i>	Not more than 6 dB down on "standard" output will result from an unmodulated input of 3 µV.

RESTRICTED

<i>Signal-to-noise ratio</i>	Under the above conditions this will be:		
			R/T and MCW:	10 dB	
			CW1:	14 dB	
			CW 2 (filter in)	18 dB	
<i>I.F. bandwidth</i>		6 dB down	60 dB down
			R/T/MCW/CW1	5.7 to 6.3 kc/s	16 kc/s
			CW2	0.75 to 1.25 Mc/s	10.5 kc/s
<i>Second channel rejection</i>	Greater than 50 dB.		
<i>I.F. rejection</i>	Greater than 80 dB.		
<i>A.F. response</i>	Not more than —1.5 dB at 300 c/s		
			Not more than —6 dB 3000 c/s, relative to level at 1000 c/s.		
<i>Distortion</i>	Not more than 15 per cent over a range of 300 to 3000 c/s		
<i>A.G.C.</i>	Less than 6 dB rise in output for an increase of input from 5 μV to 0.1 volt		
<i>Average power consumption</i>	28 volts d.c.	19 volts d.c.	Power input
			(amp)	(amp)	(watts at 28V)*
<i>Receiver ON (oven ON)</i>	3.8	2.7	185
<i>Receiver ON (oven OFF)</i>	2.8	2.7	155
<i>Altitude rating (unpressurized aircraft)</i>	30000 ft.		*Increased by 10 watts when a channel is being selected.		

Note: When operating above this altitude up to 60000 ft. all units of ARI.5874 must be in pressurized area of aircraft with the exception of the I.M.U. and tuning unit Type 7016.

SUPPRESSED AERIAL EQUIPMENT

<i>Frequency range</i>	2.8 to 18.1 Mc/s in six bands:
			Band 1 ... 18.1 to 16.5 Mc/s
			Band 2 ... 16.8 to 10.9 Mc/s
			Band 3 ... 15.5 to 7.0 Mc/s
			Band 4 ... 11.0 to 7.0 Mc/s
			Band 5 ... 10.0 to 4.7 Mc/s
			Band 6 ... 9.0 to 2.8 Mc/s
<i>No. of channels</i>	24 preset. Channel selection made by rotating turret switch remotely operated from transmitter control and drive unit.
<i>Fine tuning</i>	A fine adjustment of tuning, after automatic selection, is provided by a "shift frequency" key.
<i>Altitude rating</i>	60000 ft, maximum (see Note above).

DIMENSIONS AND WEIGHTS

		Size (in.)			Weight	
		Height	Width	Depth	lb.	oz.
10D/19065	Transmitter Type T.4188	8	8	12½	15	12
10D/19067	Power and radio unit Type 4192	8	10	12½	34	0
10L/16205	Control unit Type 4190	8	8	12½	13	9
10L/16207	Control unit Type 4243	8	8	12½	17	3
10L/16204	Control unit (remote) Type 4189	6	5	3	2	10
10D/19066	Junction box Type 4191	5	4¾	2¼	1	7
10D/19064	Receiver Type R.4187	8	8	12½	26	0
10D/19238	Tuning unit (aerial) Type 7180	8	9	12½	17	8
10D/19248	Selector unit Type 7003	8	6	12½	12	4
◀10B/16858	Impedance matching unit Type 7949	6	6	3¼	2	7
10B/16930	Impedance matching unit Type 7949A	6	6	3¼	2	7
10B/16902	Impedance matching unit Type 9541	6	6	5½	2	9
10L/293	Control unit Type 7216	5	6	4	1	11
10D/19833	Tuning unit (aerial) Type 7016	(7¾	6	20½	16	7▶

Note . . .

The total complement of units varies according to the requirements for particular installations—see Sect. 2, Chap. 10 and Sect. 3, Chap. 3.

RESTRICTED

CHAPTER 1

(Completely revised)

INTRODUCTION AND GENERAL DESCRIPTION

LIST OF CONTENTS

	<i>Para.</i>		<i>Para.</i>
<i>Introduction</i>	1	<i>Control unit Type 4190</i>	35
<i>Installations</i>	2	<i>Transmitter Type T.4188</i>
<i>Pressurization</i>	4	<i>Transmitting circuits</i>	43
<i>Operating altitudes of fixed wire aeri-als</i>	5	<i>Controls and interconnections</i>	48
<i>Remote control unit</i>	6	<i>Power and radio unit Type 4192</i>	51
<i>Inter-unit connectors</i>	10	<i>Rotary transformer</i>	53
<i>Power supplies</i>	16	<i>Audio amplifier</i>	56
<i>Variant installations</i>	17	<i>Controls and interconnections</i>	60
General description	20	<i>Control unit (remote) Type 4189</i>	62
<i>Insulated wire aerial system</i>	21	<i>Junction box Type 4191</i>	65
<i>Unit and component circuit references</i>	22	<i>Voltage regulator (5UC/6010)</i>	67
<i>Receiver type R.4187</i>	24	<i>Channel selection and tuning by remote control</i>	74
<i>Receiving circuits</i>	28		

LIST OF TABLES

	<i>Table</i>		<i>Table</i>
<i>Variant installations</i>	1	<i>Items of ARI.5874 excluding aerial systems</i>	2

LIST OF ILLUSTRATIONS

	<i>Fig.</i>		<i>Fig.</i>
<i>ARI.5874—excluding aerial units</i>	1	<i>Simple block schematic of receiver</i>	4
<i>Interconnections of receiver, transmitter and ancillary equipment</i>	2	<i>Simple block schematic of control unit Type 4190</i>	5
<i>Back panels of units</i>	3	<i>Simple block schematic of transmitter</i>	6
		<i>Simple block schematic of power and radio unit</i>	7

Introduction

1. The basic equipment of ARI.5874 includes a 24-channel crystal-controlled transmitter and receiver operating in the HF band 2.8 to 18.1 Mc/s. Operation may be on CW, MCW, or R/T with a transmitter carrier output of 100 watts approx. The complete installation forms a general purpose airborne HF communication system which may be fitted to the aircraft with suppressed aeri-als or fixed-wire aerial system. The receiver, transmitter and ancillary equipment is illustrated in fig. 1.

Installations

2. There are variant airborne installations within the one designation ARI.5874, the selected variant being dependent upon the type of aerial installation in the particular aircraft, viz.:—

(1) Suppressed aerial installation using cavity excitation; e.g., Valiant, Vulcan and Victor, etc.

(2) Fixed-wire aerial installation; e.g., Beverley.

3. Individual requirements for the variants of the installation are given in Table 1, the complement of units varying according to the type of aircraft. The equipment of the aerial systems is illustrated in Sect. 2, 3 and 4.

Pressurization

4. The installation may be used in unpressurized aircraft or fitted outside the pressure cabin (see "Leading Particulars"); the suppressed aerial tuning unit (Sect. 2) has a pressurized container.

Operating altitudes of fixed wire aeri-als

5. In aircraft fitted with fixed wire aeri-als it may be necessary to restrict the maximum operating altitude of the equipment owing to the possible occurrence of RF corona on the aerial wire. Modern wire aeri-als on high speed aircraft are improved in efficiency by the use of insulated aerial wire and specially insulated masts. The improvements include elimination of aerial leakage losses under all weather conditions and for long operational periods. Excessive strain on the aerial and its anchorages is prevented by the use of efficient aerial tensioning.

Remote control unit

6. The equipment is operated from a remote control unit. The remote control channel selection uses a self-balancing resistance bridge or Wheatstone servo (para. 74) which, on selection of a frequency channel, operates tuning motors in the transmitter, receiver and aerial tuning system.

a number of cables with separate polythene insulated wires contained in a thin polythene tube; rubber grommets are used at the clamping glands of the terminations.

13. Each cable is given a designation letter/number, marked on the cable. The terminations are marked with a number and the cable letter, the number indicating the unit to which the end is taken. The numbers agree with the unit numbers listed in Table 2; an illustration of the use of this system is shown in fig. 2.

14. The plug/socket apertures in the back-plates are similarly marked with the cable designation indicating the correct position of each cable, e.g. cable A, which is terminated by socket 1A and plug 3A, is used between the control unit Type 4190 and the power and radio unit Type 4192. The cables are listed in Chap. 10.

15. A junction box Type 4191 is interposed between the connectors of the main transmitting/receiving units and the remote control unit (fig. 1 and 2). The terminations are marked with a code used on the connectors (para. 65).

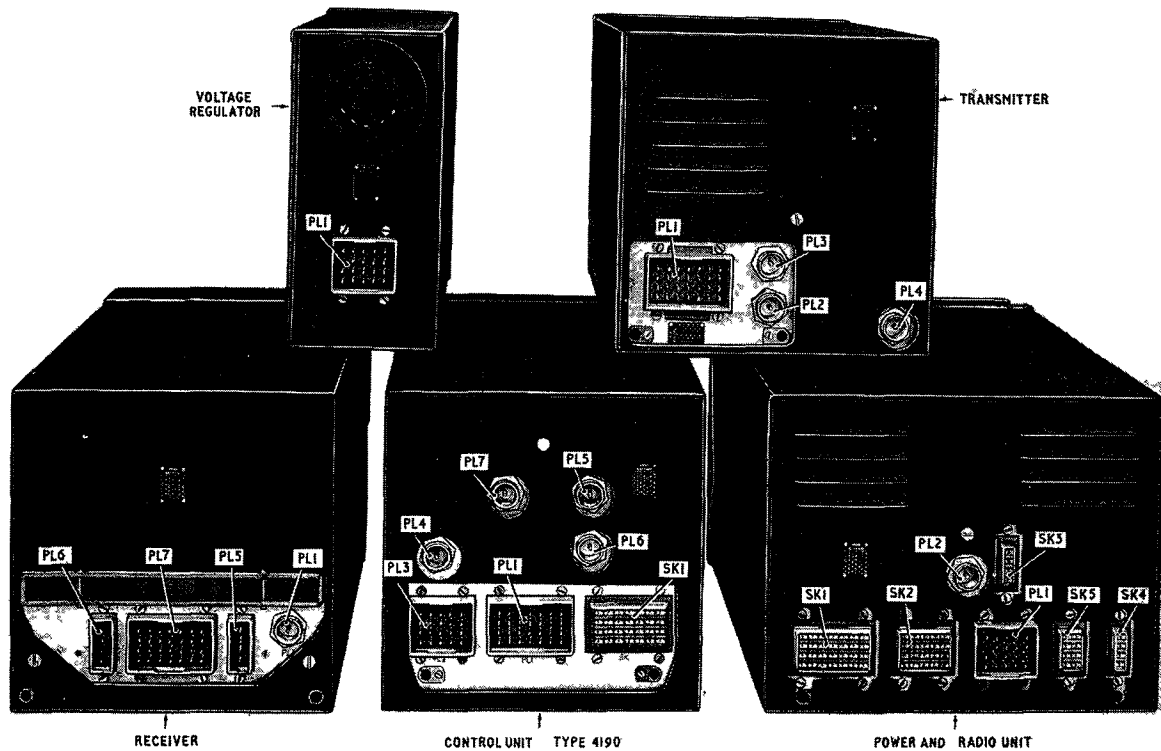

Fig. 3. Back panels of units.

Power supplies

16. Input power to the complete installation is derived from the aircraft 28-volt supply system. This provides the input to a power and radio unit which in turn provides HT for the transmitter unit. The receiver unit incorporates its own rotary transformer which supplies 220V HT for the receiver circuits. For certain LT circuits a stabilised supply of 19V DC is required. This

is provided by a voltage regulator fed from the aircraft 28V supply system.

Variant installations

17. The complete airborne radio installation includes the following main units; the selected items for suppressed and fixed aerials installations are indicated in Table 1.

TABLE 1
Variant Installations

<i>Unit</i>	<i>Suppressed aerial installations (Cavity)</i>	<i>Fixed wire aerial installations</i>
1 Transmitter Type T.4188	1	1
2 Receiver Type R.4187	1	1
3 Control unit Type 4190 (transmitter drive)	1	—
4 Power and radio unit Type 4192	1	1
5 Control unit (remote) Type 4189	1	1
6 Junction box Type 4191	1	1
7 Aerial tuning unit Type 7016	1	—
8 Impedance matching unit Type 7949	1	—
9 Aerial selector unit Type 7003	1	—
10 Aerial control unit (remote) Type 7216	1	—
11 Control unit Type 4243 (transmitter drive)	—	1
12 Aerial tuning unit Type 7180	—	1

18. Of the above units, items 1 to 6 form the transmitting/receiving nucleus of the ARI.5874 and are described in this Section 1. Items 7 to 10 are used with items 1 to 6 in aircraft with suppressed aerial systems and are described in Section 2. The remaining items 11 and 12 are used with items 1, 2, 3, 5 and 6, and are described in Section 3. (Item 11 replaces item 3 in fixed aerial systems.)

19. A voltage regulator (5UC/6010) is included in all three variants of the installation; it is described in Chapter 8 of this Section 1.

GENERAL DESCRIPTION

20. The general description in this chapter deals briefly with the items in Table 2.

TABLE 2
Items of ARI.5874 excluding aerial systems

<i>Unit</i>	<i>Ref. No.</i>	<i>Chap.</i>	<i>Unit circuit ref.</i>
Power and radio unit Type 4192	10D/19067	5	3
Control unit Type 4190	10L/16205	3	1
Transmitter Type T.4188	10D/19065	4	2
Receiver Type R.4187	10D/19064	2	4 (1) (2) (3)
Control unit (remote) Type 4189	10L/16204	6	11
Junction box Type 4191	10D/19066	6	12
Voltage regulator (5UC/6010)	5UC/6010	8	—

Note . . .

Additional items peculiar to suppressed aerial installations are described in Sect. 2. Items for use only in fixed-wire aerial installations are described in Sect. 3. Wire aerial fixings for particular types of aircraft are described in Sect. 4.

Insulated wire aerial system

21. Most modern aircraft using wire aerials are fitted with special insulated masts and aerial wire. The type of mast and tensioning unit varies with the type of aircraft. Full descriptions are given in Sect. 4.

Unit and component circuit references

22. Where a description involves more than one unit, abbreviated references are used as indicated in Table 2, column 4. For the receiver circuits

the reference is further broken down as follows:—

IF unit	4 (1)
RF unit	4 (2)
Chassis assembly	4 (3)

23. The reference numbers are used throughout the book to prefix component references and thus indicate to which unit the particular component belongs, e.g., relay RL3/2 on the receiver chassis assembly will be referred to as 4(3)RL3/2, resistor R10 on the transmitter will be 2R10.

R E S T R I C T E D

Receiver Type R.4187

24. The receiver Type R.4187 is virtually a "self-contained" unit within the installation since it incorporates its own power unit operating from the aircraft battery supply and all those circuits necessary for the reception of signals from the aerial input.

25. A number of individual units are mounted on the main chassis and are designated as follows:—

- (1) Chassis assembly Type 4211 (main chassis) including:—
 - (a) Power unit Type 4231
 - (b) Crystal unit oven Type 12
 - (c) 24 crystal units—ZDH at ± 2.15 Mc/s of signal frequency depending on the frequency band (receiver) in use.
 - (d) Selector unit Type 4230.
- (2) Amplifying unit Type 4207 (RF head) including:— Drive unit mechanical Type 4232 (tuning unit).
- (3) Amplifying unit Type 4208 (IF unit).

26. From a constructional point of view, the receiver chassis consists of the chassis assembly Type 4211 and the front panel. The crystal unit oven is built into the side of the chassis assembly; the rotary transformer and the channel selector unit are mounted as fixed items. The two amplifying units are mounted on separate sub-chassis which "plug-in" to the top of the chassis assembly.

27. At the rear of the chassis are fitted a number of plugs and sockets which mate with others in the receiver back-plate for interconnection with other units of ARI.5874.

Receiving circuits

28. The receiver tuning range is divided into three frequency bands with the following coverage;—

- Band 1 2.8 to 5.2 Mc/s
- Band 2 5.2 to 9.7 Mc/s
- Band 3 9.7 to 18.1 Mc/s

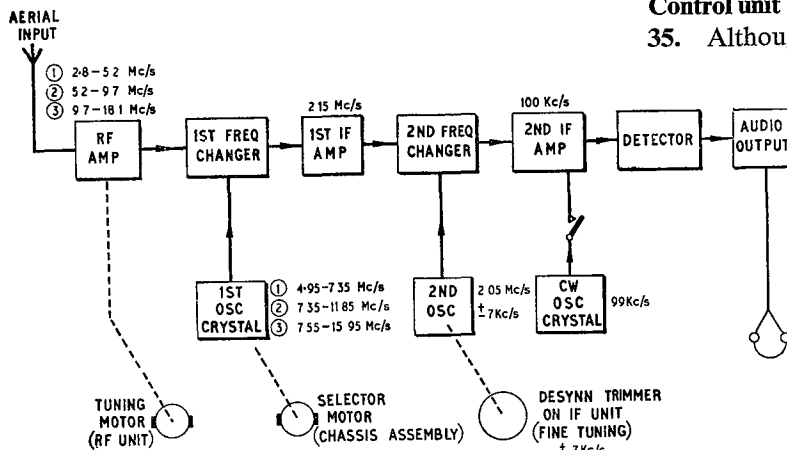

Fig. 4. Simple block schematic of receiver.

29. The operative frequency is selected by "Band" relays in the RF amplifier, the selected inductors being tuned by a motor-driven ganged capacitor.

30. A simple block schematic of the receiver circuit is given in fig. 4. Signals from the aerial system are applied via the RF amplifier to the 1st frequency changer where the signal frequency is changed to the 1st intermediate frequency of 2.15 Mc/s. After amplification at this frequency a further change is made to the 2nd IF frequency of 100 kc/s.

31. The 1st oscillator is crystal-controlled at the signal-frequency plus or minus 2.15 Mc/s. On ranges 1 and 2 the crystal frequencies are the signal-frequencies plus 2.15 Mc/s and on range 3 they are the signal-frequency minus 2.15 Mc/s. This arrangement keeps the crystal unit's frequencies within the minimum possible range and limits spurious signals normally present in this double super-heterodyne receiver.

32. Variation of the 2nd oscillator frequency provides a fine tuning control with plus or minus 7 kc/s frequency deviation (thus providing this variation at signal frequency); the variation is made by means of a small capacitor driven by a Desynn motor. This variation also provides the beat note adjustment when receiving CW.

33. Provision is made for the reception of CW by the inclusion of a 99 kc/s crystal oscillator to give a beat note of 1,000 c/s when tuned to the carrier frequency. This beat note can be varied in pitch by means of the fine tuning control referred to in para. 32.

34. Automatic gain control circuits are included and noise limiting is provided in the output of the audio detector.

Control unit Type 4190

35. Although a description of the control unit Type 4190 is included in this Section (Chap. 3) it is used only in those aircraft fitted with suppressed aerial systems. It is necessary to describe the function of the control unit as an essential part of the operation of the transmitting circuit of the ARI.5874. For those aircraft fitted with fixed-wire aerial systems, the control unit Type 4243 is used; this is described in Sect. 3. A simple block schematic of the function of control unit Type 4190 is given in fig. 5.

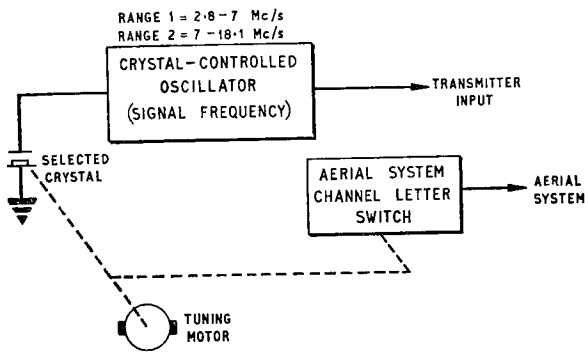

Fig. 5. Simple block schematic of control unit Type 4190.

36. The control unit Type 4190 is the control and drive unit of the transmitter and includes all the control circuits necessary to operate the transmitter, together with the preset potentiometers for setting-up the channels. The control unit is fitted with 24 crystals and an aperiodic crystal oscillator which determines the transmitter frequency and gives a nominal 2 volts at the signal frequency into a 70-ohm cable feeding the transmitter. The crystals are heated in thermostatically controlled enclosures, the heaters of which do not allow the temperature to fall below 10 deg. C.

37. A number of relays are fitted to the control unit chassis, one of which acts as the low impedance aerial changeover relay. The latter is mounted on a relay panel at the rear of the chassis, and is designated relay unit Type 4216.

38. An illustration of the front panel of the control unit Type 4190 is given in fig. 1. The panel is fitted with most of the controls necessary to set up the transmitter unit. The upper half of the front panel is occupied by the channel potentiometer controls; these are part of two 12-way potentiometers described as resistors, Type 10462.

39. Beneath the potentiometers are mounted 24 channel switches which are used for setting-up purposes. The potentiometers and switches are not shown in fig. 1.

40. A selector motor, motor unit Type 4214, is mounted in the centre of the chassis and drives a shaft operating a multi-bank switch from which is made all the switching necessary for automatic channel selection.

41. Two crystal ovens, Type 13 and Type 14, house the 24 crystals which are selected by the channel selection system and applied to the crystal oscillator circuit. The oscillator is mounted on a separate sub-chassis and is designated oscillator unit Type 4215.

42. At the rear of the chassis are mounted a number of plugs and sockets for interconnection

with other units of the complement of ARI.5874. The connections are made through the back-plate of the control unit Type 4190.

Transmitter Type T.4188

Transmitting circuits

43. The transmitter Type T.4188 consists mainly of three tuned amplifiers, a mechanical drive unit which includes the tuning motor, and a blower motor for air-cooling the P.A. stage.

44. All the components are mounted on a cast aluminium chassis (chassis assembly Type 4210) and sub-chassis attached thereto.

45. A simple block schematic of the transmitter circuit is given in fig. 6. The input from the crystal-controlled oscillator in the control unit Type 4190 (control and drive unit) is applied to an input amplifier in the transmitter, thence to a driver stage and finally to a power amplifier stage; all stages are at signal frequency. The RF output from the final stage is applied to an aerial changeover relay in the control unit Type 4190.

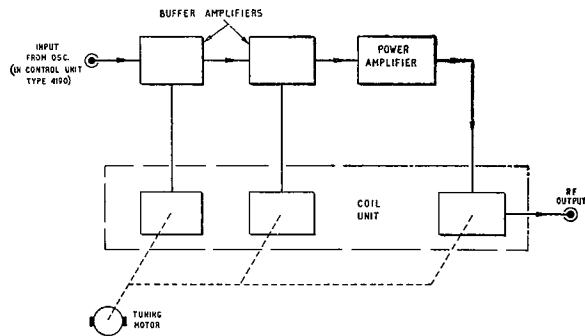

Fig. 6. Simple block schematic of transmitter.

46. The coil unit contains three tuned coil sections, one to each amplifier; the coils are ganged and tuned by a mechanical drive from the drive unit Type 4212.

47. The power amplifier is cooled by a blower motor mounted beneath the valves and driven from the 28-volt supply to the equipment.

Controls and interconnections

48. An illustration of the front panel of the transmitter is given in fig. 1. A TUNE KEY is provided to facilitate the checking of the valve currents with the aid of the meter switch.

49. The changeover from automatic to manual control is possible using the AUTO/MAN switch. In the manual condition, the transmitter coils can be rotated by means of the TRANS/TUNE knob to enable a mechanical check to be made during inspection of the equipment. The transmitter HT is not available in this condition.

50. A number of plugs and sockets are fitted to the rear of the chassis; these connect with others mounted on the transmitter back-plate for interconnection with other units of the ARI.5874.

Power and radio unit Type 4192

51. The chassis of the power and radio unit Type 4192 carries the following main items:—

- (1) Rotary transformer Type 7973 and associated filter unit Type 4213.
- (2) Amplifying unit Type 4029 (superseded by amplifying unit Type 7435).
- (3) Transformer Type 3613.

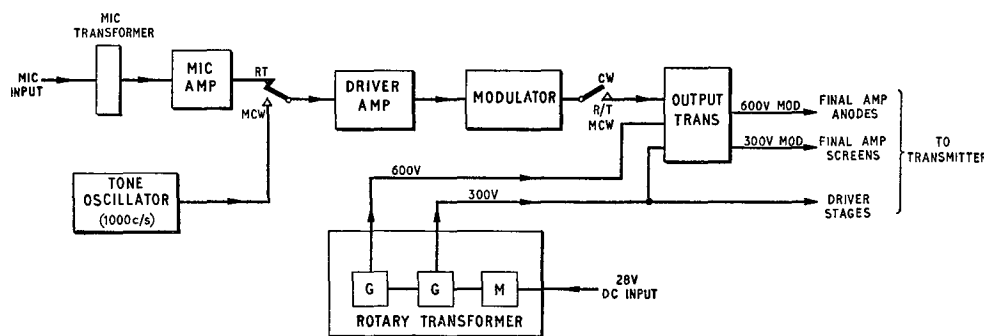

Fig. 7. Simple block schematic of power and radio unit.

52. A number of other items associated with the remote control and switching of the above items are mounted on the main chassis of the power and radio unit; they are described in detail in Chap. 5. A simple block schematic of the power and radio unit is given in fig. 7.

Rotary transformer

53. The rotary transformer is intended to operate at a nominal input voltage of 28 volts as normally provided by the aircraft battery supplies. There are two secondary windings, one giving 300V HT and the other 600V HT; these outputs supply HT to the incorporated audio amplifier (amplifying unit Type 4209 or 7435), the transmitter Type T.4188 (Chap. 4) and the crystal-controlled oscillator in the control Type 4190 (Chap. 3) or Type 4243 (Sect. 3).

54. Filtering of the 300V and the 600V outputs is provided by two filters mounted beneath the rotary transformer in the filter unit Type 4213. A "two-step" motor starting device employs two heavy duty relays and a wire-wound resistor which are also mounted in the filtering unit.

55. An air supply for cooling purposes is drawn through an air filter unit on the front panel by a fan mounted on the rotary transformer shaft at the LT end of the machine.

Audio amplifier

56. The microphone input is applied to the 1st amplifier via the microphone transformer and thence to a modulator driver stage. For MCW facilities a tone oscillator is provided and the output switched to the driver stage as required.

57. The modulator stage consists of four valves operating in parallel push-pull. The input to

the modulator is from a transformer in the driver stage.

58. When CW facilities are required, the modulator valves are biased off by relay switching; sidetone is available from the tone oscillator.

59. Voice-operated gain adjustment is provided by feedback from the modulator output to the microphone amplifier.

Controls and inter-connection

60. The predominant feature of the front panel of the power and radio unit (fig. 1) is the louvred cover over the air filter. Other features are the three preset controls for adjustment of levels in the V.O.G.A.D. (DELAY), SIDETONE and MCW circuits, and the input fuses.

61. For interconnection with the remainder of the installation and the input power supplies, a number of plugs and sockets are mounted at the rear face of the chassis (fig. 3). When the unit is in position on the rack mounting, these plugs and sockets mate with others mounted on a back-plate which forms the termination of several connectors. Details of the power and radio unit back-plate are given in Chap. 10.

Control unit (remote) Type 4189

62. All the units of the ARI.5874 are operated from the remote control unit Type 4189. No "local" control facilities are available and all power and service switching is made at the control unit both for operation and setting-up the equipment.

63. The control unit is designed for either panel or console mounting. Two angle brackets are fitted to the cover of the control unit and these will be fixed either to the rear of the cover for panel mounting or flush with the front panel for console mounting. The multipole socket can be brought out to the rear of the control unit for console mounting or to the underside of the control unit for panel mounting.

64. The controls and switches on the front panel of the control unit give the following services (fig. 1) :—

- (1) Channel letter (selection) switch. Provides an open-circuit in the selector motor relay when the chosen channel has been selected.
- (2) Channel number switch. Selects one of the two channel groups 1A to 1M or 2A to 2M.

(3) Power switch. OFF-S/BY-TX.

s/BY. Standby; switches on receiver and puts transmitter to standby, *i.e.*, heaters on.

TX. Switches on transmitter HT.

(4) Service switch. Chooses the service required on receiver and transmitter:—

R/T. Gives R/T facilities for transmission and reception when the key circuit is closed.

MCW. Puts transmitter on MCW.

cw1. Puts transmitter on CW. Switches on the CW oscillator at the receiver and reduces the audio output by 6dB.

cw2. As for CW1 but with higher selectivity in the IF amplifier.

INT. This gives an intertune facility by keying the transmitter oscillator only and breaking the receiver mute line to permit reception of a signal from the transmitter.

FINE TUNING. Controls a Desynn motor affecting the frequency of the receiver 2nd oscillator by a variation of plus or minus 7 kc/s. May also be used as a beat note control.

Note . . .

The dial reads error plus-or-minus in range 2.8 to 9.7 Mc/s and minus-or-plus for 9.7 to 19.1 Mc/s, i.e., the calibration changes sign at 9.7 Mc/s.

RF GAIN. Controls RF gain of receiver.

DIM. Panel illumination.

TUNE. Tuning lamp dimmed by an iris. Glows when any tuning operation is in progress, but will not operate when the transmitter is switched to MANUAL.

Meter. The meter indicates aerial excitation when the transmitter is on, "mark".

Junction box Type 4191

65. The junction box Type 4191 is bulkhead mounted and connects the remote control unit to the receiver and transmitter circuits. It has one multi-pole socket and two multi-pole plugs connected as follows:—

Marking

12AH — Connects to the remote control unit via a 25-way cable.

12AD — Connects to the receiver unit via a 25-way cable.

12AE — Connects to the control unit Type 4190 (transmitter drive) via a 25-way cable.

66. Other than the wiring to the above there are no electrical components in the junction box.

Voltage regulator (5UC/6010)

67. The input power supplies to the ARI.5874 equipment require a nominal 28 volts DC from the aircraft battery supply and a regulated supply of 19 volts DC. The latter supply is derived from the 28-volt supply by use of the voltage regulator.

68. The voltage regulator is a carbon-pile type designed to give a constant output of 19 volts from an input which may vary between 22 and 29 volts. To dissipate the heat of the carbon-pile, a cooling fan is fitted.

69. On the front panel of the voltage regulator (*fig. 1*) are mounted a voltmeter and the following controls and switches:—

ADJUST VOLTS. A manual control of the volts potentiometer which is calibrated with an arbitrary scale and can be locked after adjustment.

CHECK. A press-release switch for output level tests.

SET. A press-release switch for output level adjustments.

LIGHT. A push-pull switch controlling the illumination of the voltmeter.

70. Although the potential level of the output is 19 volts, arrangements are made for this to be varied between 18 and 20 volts by means of variable wire-wound resistive elements.

71. An illuminated voltmeter mounted on the front panel indicates the level of the output voltage, the limits of 18 and 20 volts being clearly defined. A scaled control on the front panel is provided for adjustment of the stabilized potential level.

72. The regulator is capable of supplying either 2 to 10 amperes or 5 to 25 amperes. The change-over from one range to the other is effected by replacing one plug-in type resistor by another.

73. A 20-pole plug is mounted at the rear of the unit for making the necessary connections to incoming and out-going supplies through a back-plate which connects to the remainder of the radio installation.

Channel selection and tuning by remote control

74. The remote control system used to tune the equipment includes selector circuits and tuning circuits. The system employs the self-balancing resistance bridge or Wheatstone servo.

75. If a frequency channel is selected by use of the channel number and channel letter switches on the control unit (*fig. 1*), the selector motors on the receiver and the drive unit of the transmitter operate and eventually stop at the position corresponding to the selected channel. The tuning motors will then operate and eventually stop at the positions predetermined by the potentiometer settings.

76. Motor-driven potentiometers in the receiver and transmitter selector circuits are each connected to form a resistance bridge with an associated potentiometer in the respective tuning circuits of the receiver and transmitter.

77. The bridge is unbalanced by the operation of the channel selector switches on the remote control unit and the consequent out-of-balance current is detected by a sensitive centre-stable moving coil relay. The direction of the out-of-balance current determines the direction of movement of the relay contact and this contact is used to operate one of two slave relays which will subsequently cause

the tuning motor to be driven in a direction dependent upon the selected slave relay.

78. The slave relays turn the tuning motor in one direction or another such that the potentiometer coupled to the motor is driven towards the balance point of the resistance bridge.

79. At balance, the sensitive relay contact rests in the centre-stable position and the motor stops. To avoid over-shooting of the balance point, a feedback circuit operates through a second winding on the sensitive relay. A protective relay is connected in parallel to limit the current in the sensitive relay when the out-of-balance current is large.

80. For remote control tuning of the transmitter and receiver, each requires 24 preset resistance ratios as remote control elements (*para.* 76). Such an arrangement would normally involve 48 setting potentiometers, but this is overcome by the use of special potentiometers each of which can provide 12 resistance ratios when rotated by the

selector motors. The requirement is thus reduced to four 12-way potentiometers, two each in the transmitter and receiver selector circuits being used on a 2×12 basis to provide the 24 ratios needed. The tuning circuit potentiometers are continuous-wiping and are driven by the respective tuning motors through the 24 channel positions as selected.

81. The selector switch on the receiver and the transmitter is motor driven, with channel selection control from the remote control unit. A six-wire system is used, the appropriate selected channel being "unearthed"; all other channels provide an earth on the motor circuits and thus drive the motor until the open-circuit on the selected channel is reached.

82. The six-wire system uses special switch banks which provide twelve-positional control. A full description of the remote control system with simplified diagrams is given in Chap. 7.

RESTRICTED

Chapter 2

RECEIVER TYPE R.4187

LIST OF CONTENTS

	Para.		Para.
Introduction	1	First IF amplifier	50
Construction	6	Second frequency-changer	51
Chassis assembly Type 4211	8	Second IF amplifier	54
Power unit Type 4231	10	CW reception	57
Crystal oven Type 12	12	AGC circuit	60
Selector unit Type 4230	13	Audio detector	61
Front panel assembly	16	Noise limiting	62
Amplifying unit Type 4207 (RF unit)	20	AF amplification	65
Amplifying unit Type 4208 (IF unit)	28	Control circuits	68
Circuit description	36	Front panel controls	69
Aerial input to receiver	37	Motor-operated channel selection circuits	
Band selection	38	Selector switch S1	73
Limiter	40	POT.1/POT.2	74
RF amplifiers	41	Relay circuits	75
First frequency-changer	46	Receiver power supply circuits	82
		Function of receiver tuning circuits when setting-up a channel	87

LIST OF ILLUSTRATIONS

	Fig.		Fig.
Receiver-top of chassis	1	RF unit—underside of chassis	9
Chassis assembly Type 4211	2	Amplifying unit Type 4208 (IF unit)	10
Removal of power unit	3	IF unit—underside of chassis	11
Side view of receiver	4	Block diagram of receiver circuit	12
Selector unit Type 4230—front	5	Amplifying unit Type 4207—circuit	13
Front panel of receiver	6	Amplifying unit Type 4208—circuit	14
Underside of receiver chassis	7	Chassis assembly Type 4211—circuit	15
Amplifying unit Type 4207 (RF unit)	8		

INTRODUCTION

1. The receiver Type R.4187 consists of a number of individual units mounted on one main chassis assembly, these include a power unit providing HT for the receiver circuits.

2. The complement of units in the receiver is as follows :—

Receiver Type R.4187 (10D/19064) consisting of :—

- | | |
|---|-----------|
| (1) Chassis assembly Type 4211 | 10D/19077 |
| (2) Amplifying unit Type 4207 (RF unit) | 10U/16831 |
| (3) Amplifying unit Type 4208 (IF unit) | 10U/16832 |
| (4) Power unit Type 4231 | 10K/17986 |
| (5) Selector unit Type 4230 | 10D/19085 |
| (6) Drive unit mechanical Type 4243 | 10AR/2219 |
| (7) Filter unit Type 4235 | 10P/16065 |
| (8) Filter unit Type 4236 | 10P/16066 |

3. In addition to the above items the chassis assembly Type 4211 includes a crystal oven Type 12 in which are accommodated 24 crystal units ZDH at plus or minus 2·15 Mc/s off signal frequency (*para.* 4).

4. The receiver frequency range is divided into three frequency bands with the following coverage.

Band 1.....2·8 to 5·2 Mc/s (crystal frequency = signal frequency + 2·15 Mc/s).

Band 2.....5·2 to 9·7 Mc/s (crystal frequency = signal frequency + 2·15 Mc/s).

Band 3.....9·7 to 18·1 Mc/s (crystal frequency = signal frequency — 2·15 Mc/s).

5. The operative frequency band is selected by “Band” relays in the RF amplifier, the selected inductors being tuned by a motor-driven ganged capacitor.

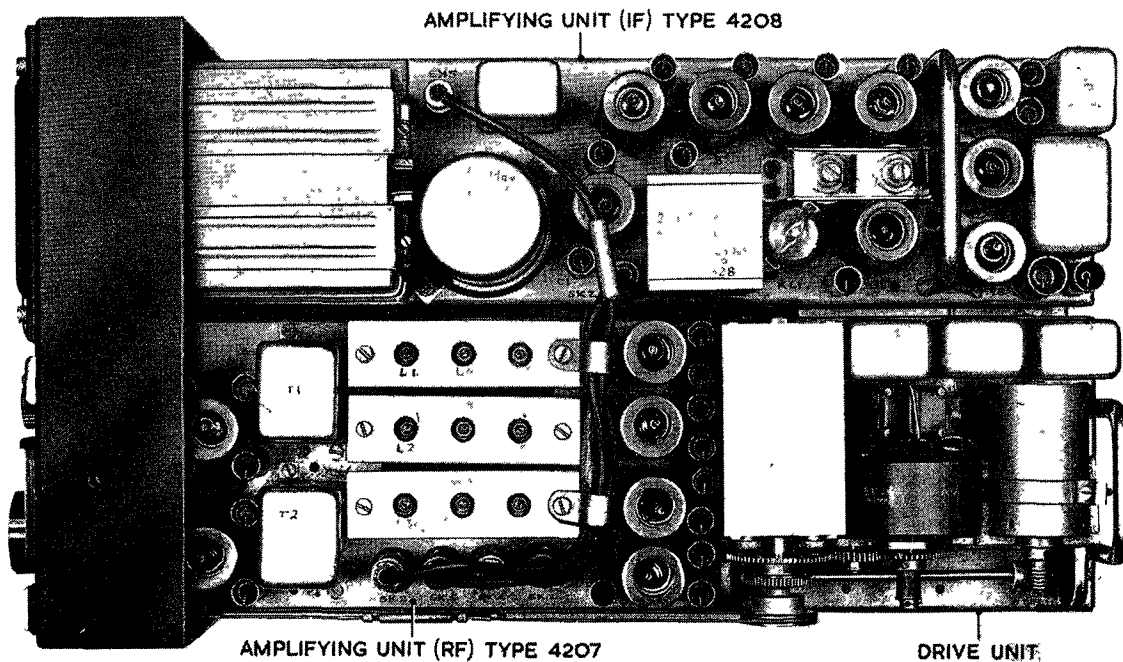

Fig. 1. Receiver-top of chassis

CONSTRUCTION

6. The receiver Type R.4187 consists of a chassis assembly supporting the front panel measuring 8×8 in., on which is mounted all the manual controls required for setting-up purposes. The depth of the receiver is $12\frac{1}{2}$ in.

7. On top of the chassis assembly (*fig. 1*) is fitted the RF unit (amplifying unit Type 4207) and the IF unit (amplifying unit Type 4208). The complete chassis and sub-units are enclosed by a removable dust cover fixed by quick release fasteners at the rear.

Chassis assembly Type 4211

8. The chassis assembly Type 4211 consists mainly of the power supply and remote control circuits and comprises the lower half of the complete receiver with the front panel attached (*fig. 2*).

9. At the rear of the chassis is a bracket on which is horizontally mounted two 12-way sockets SK1 and SK2 connecting with the RF and IF units. The rear face of the bracket has a wire mesh outlet for the cooling air and mounts the four plugs engaging with the cables mounted on the back-plate of the receiver mounting unit. These are:—

(4L)	PL1	Coaxial plug	Input from tuned aerial.
(4M)	PL5	4-pole plug	Aircraft power supply input (19V and 28V).
(4N)	PL6	4-pole plug	Audio output to telephones.
(4AD)	PL7	28-pole plug	Connections to remote control unit.

Note . . .

The references in parenthesis are the back-plate codings for the associated sockets (Chap. 10).

10. Immediately in front of the rear bracket is mounted the rotary transformer. This, with its interference suppression filters forming a mounting base, is a complete power unit Type 4231 and can be withdrawn on removal of four screws through the base of the chassis (*fig. 3*). The electrical connections to the main chassis are made via the terminal block G and these must be disconnected before removing the power unit.

11. A fan on the rotary transformer draws air through the body of the receiver from a filtered inlet on the front panel and expels it through the outlet on the rear bracket. The housing of the machine and the bracket form an enclosure from the rest of the equipment (*fig. 2*).

Crystal oven Type 12

12. In front of the power unit enclosure at the side of the main chassis is mounted the crystal oven Type 12 (*fig. 4*). The oven accommodates 24 crystals in numbered sockets and is thermostatically controlled at 50 deg. C to restrict the temperature range (40 to 70 deg. C) over which the crystals are to operate.

Selector unit Type 4230

13. At the left-hand front of the main chassis is the selector unit Type 4230. This includes two 12-way potentiometers and 24 3-position switches which protrude through the front panel. The two potentiometers POT. 1 and POT. 2 have plug connections

RESTRICTED

and are capable of withdrawal through the front panel (fig. 5).

14. To the rear of the 3-position switches is the selector motor, its filter, and the gearing which turns the potentiometers and operates the 8-bank ganged switch S1. The four rear banks of the switch are connected to the crystals oven for the selection of the channel crystals.

15. The bracket on which is mounted the selector motor also carries the double-triode valve V1 and associated components of the crystal oscillator.

Front panel assembly

16. The front panel is bolted on the front of the chassis assembly and carries the controls and switches listed below (fig. 6).

- | | |
|---|--|
| <p>(1) Drum dial and TUNE control used in setting-up receiving channels with dial lamp PL2 at rear.</p> | <p>(2) Receiver TUNING indicator lamp LP1.</p> <p>(3) Channel band switches S9 and S10 (under cover).</p> |
| | <p>(4) Two 12-way potentiometers POT. 1 and POT. 2 (under cover).</p> <p>(5) Fuses: F1—HT; F2—19V; F3—28V (and spares for each)</p> <p>(6) TUNE/NORMAL switch s2.</p> <p>(7) AGC ON/OFF switch s3.</p> |

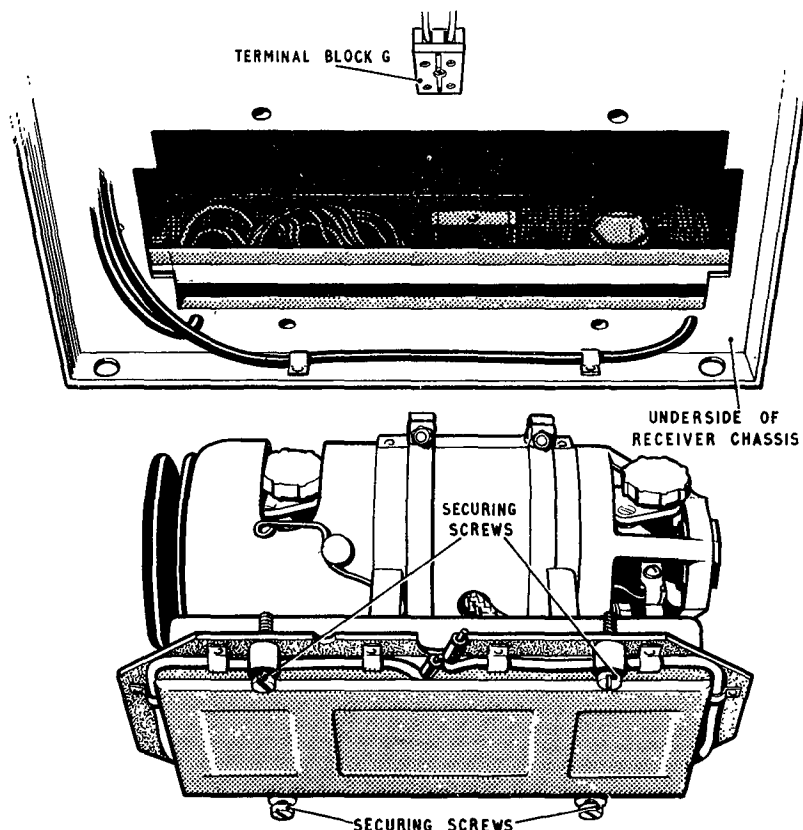

Fig. 3. Removal of power unit

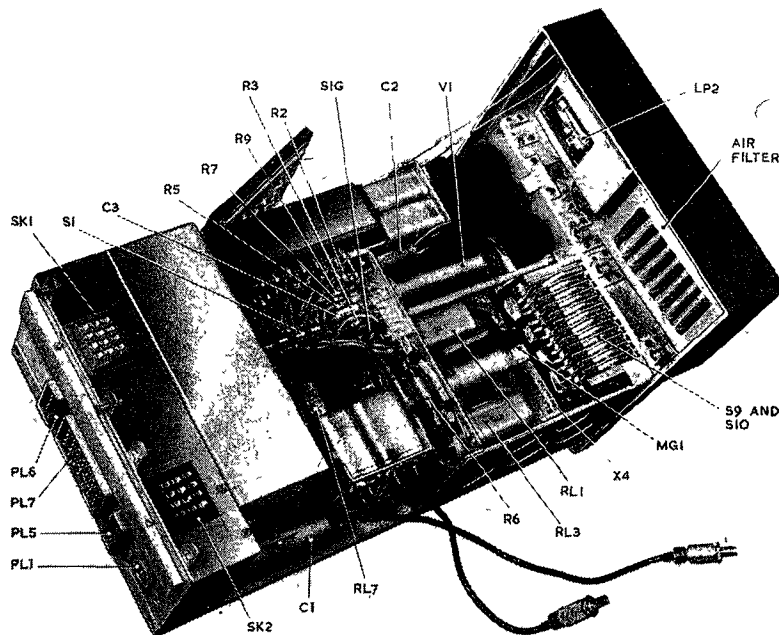

Fig. 2. Chassis assembly Type 4211

17. In addition to the items listed above is an air filter which is used as an air inlet for the cooling system of the receiver; this can be exposed and withdrawn after removal of the louvred cover at the top left of the front panel.

18. Access to the potentiometers and channel band switches is by removal of the cover carrying the CHANNEL/FREQUENCY allocation card at the lower left of the front panel. This cover is constructed with a special projection to prevent the TUNE/NORMAL switch being left in the TUNE position when the cover is in position. The function of the front panel controls is explained in the circuit description (para. 69 to 74).

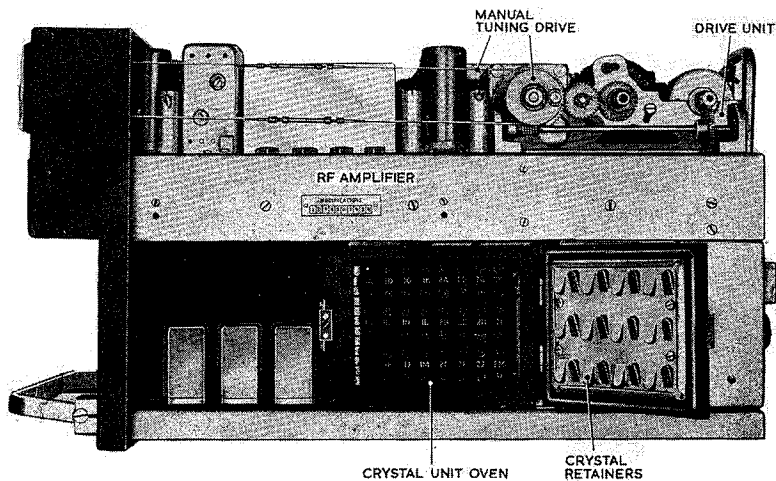

Fig. 4. Side view of receiver

19. The underside of the shallow chassis forming the base of the chassis assembly has fixed to it three tag strips (fig. 7); each tag is being marked with a number. To these are brought the cable forms from the front panel, the selector unit, the back bracket and the control relays. The tag strips enable the necessary cross connections to be made between these units, and provide accessible test points.

Amplifying unit Type 4207 (RF unit)

20. The amplifying unit Type 4207 is mounted on the right-hand side on top of the chassis assembly (fig. 8). The RF unit measures 4 by 12 $\frac{3}{8}$ by 1 $\frac{1}{2}$ in. deep with the valves and coil assemblies mounted on its upper surface; it is held in position by two spigots engaging on the front panel of the receiver and by two screws on the rear bracket.

21. When the RF unit is in position on the main chassis a 12-pole plug PL1 on the underside of the chassis engages with a socket SK1 on the rear bracket of the receiver. Four coaxial plug-socket connections are also made to the chassis assembly (SK2-3-4-5).

22. At the rear of the unit is the drive unit mechanical Type 4243 including the tuning motor geared to a 3-gang variable capacitor and to the balancing potentiometer of the remote control circuit. The associated relays RL1, RL2 and RL3 are mounted alongside the drive unit.

23. In front of the drive unit are the valves of the first stages V1 to V4 and the coil assemblies of the RF stages. Each assembly consists of three coils, one for each of the three frequency bands into which the receiver frequency range is divided. These coils are mounted in a single screening can which also carries on its base the two sealed relays that effect band change (fig. 9).

24. The coil assemblies are held on the chassis by two screws; the trimmer capacitors C2, C10 and C17 for the 3-gang capacitor associated with the coils are mounted in screened compartments on the underside of the chassis.

25. At the side of the coil assemblies are the four coloured RF sockets which connect the RF unit to the remainder of the receiver. These are from front to back (of the receiver) :-

- SK3 2nd oscillator input —green—To IF unit.
- SK5 Aerial input—red—To chassis assembly.
- SK4 1st IF output—yellow—To IF unit.
- SK2 1st oscillator input —blue—To chassis assembly.

26. At the front of the RF unit are the two 1st IF transformers T1 and T2 and the 1st IF amplifier valve V5 and 2nd frequency-changer valve V6.

27. The interference suppression filter for the tuning motor is mounted on the underside of the chassis below the motor.

Amplifying unit Type 4208 (IF unit)

28. The amplifying unit Type 4208 is located at the left-hand side of the top of the chassis assembly (fig. 10). The IF unit measures 3 $\frac{3}{8}$ x 12 $\frac{3}{8}$ x 1 $\frac{1}{2}$ in. deep. It is held in position by two spigots engaging on the front panel of the receiver and by two screws on the rear bracket.

29. A 12-pole plug PL1 on the underside of the IF unit engages with a similar socket SK2 on the chassis assembly. Two coaxial sockets are used to join the IF unit to the RF unit when in position on the main chassis assembly.

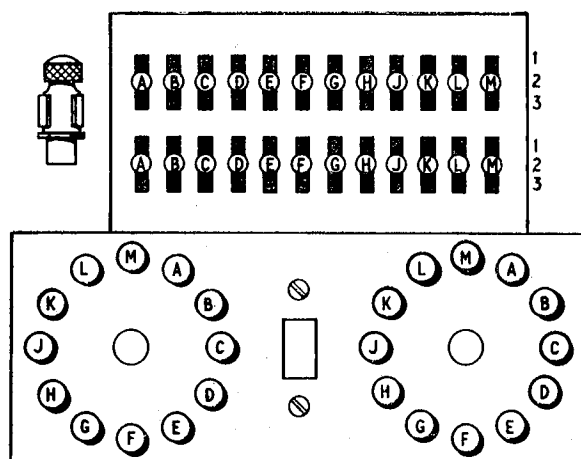

Fig. 5. Selector unit Type 4230—front

30. At the rear of the IF unit is mounted the audio output transformer T1, the audio valve stages V7-8-9 and the two potentiometers RV3 and RV4 presetting the audio output on R/T and CW.

31. In front of these is the crystal XL1 and the CW oscillator valve V6, the valves of the 2nd IF amplifier V2-3-4 and the variable second oscillator V1. The latter consists of a coil and capacitor assembly X2 mounted in a screened box and a variable capacitor operated by means of a Desynn motor, which controls the tuning of the oscillator V1.

32. The variable capacitor is mounted in a sealed oil-filled container to provide mechanical damping; this together with its motor, forms an assembly X1 which plugs into a valve socket. This capacitor assembly X1 is compensated against the core and capacitor assembly X2 in production and the two units bear the same serial number.

Note . . .

It is most important that these two units always have the same Serial number especially as the variable capacitor is a plug-in unit. In the event of unserviceability of either unit both must be replaced. The units are available as spares in the form of matched pairs. (In an emergency the compensation error produced by changing only one of the pair could be tolerated).

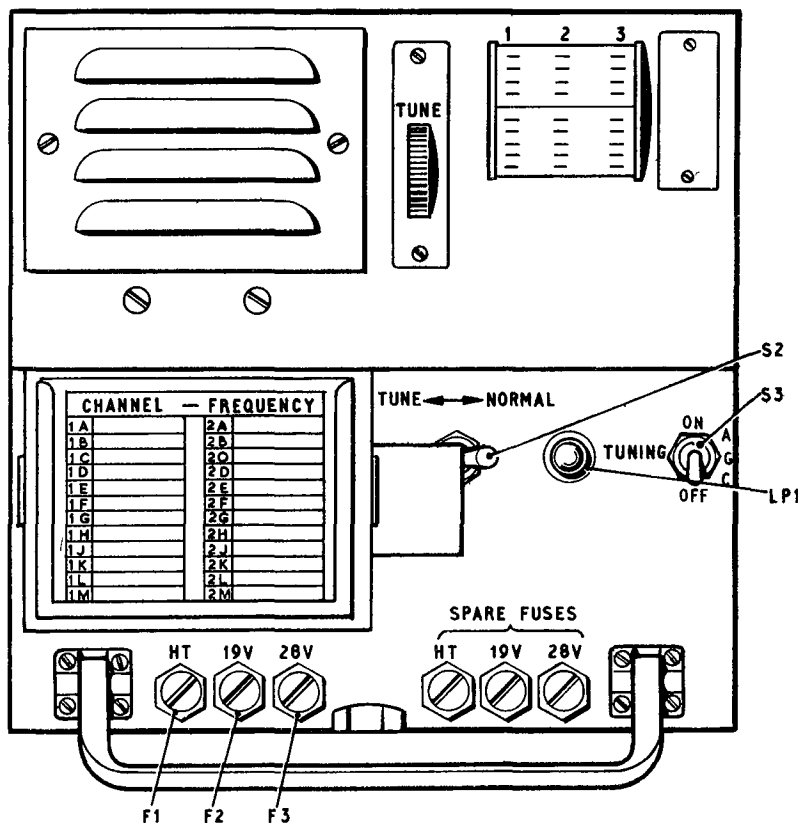

Fig. 6. Front panel of receiver

33. Two coaxial coloured sockets are mounted on top of the chassis and are joined by means of coaxial cables to the RF unit.

- (1) SK2 2nd oscillator output—green
- (2) SK3 IF input—yellow.

34. At the front of the IF unit are the two 100 kc/s IF filters X3 and X4; these are in sealed boxes and the wide-band filter (the larger) is mounted on top of the chassis, whilst the narrow-band filter (the smaller) is mounted on the underside of the chassis. Both are held in position by retainer clamps.

35. The underside of the chassis (fig. 11) is sub-divided into compartments separating the stages of the amplifier.

CIRCUIT DESCRIPTION

36. The receiver circuit is covered by three diagrams :—

- Amplifying unit Type 4207 (RF unit)—fig. 13.
- Amplifying unit Type 4208 (IF unit)—fig. 14.

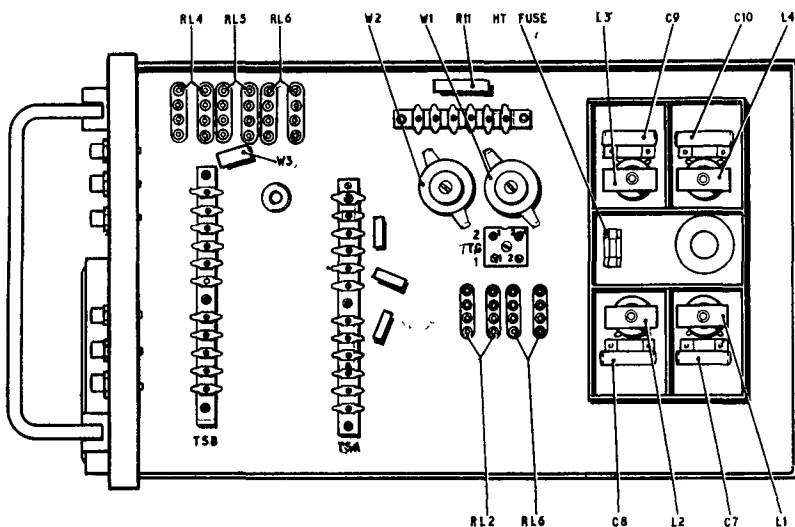

Fig. 7. Underside of receiver chassis

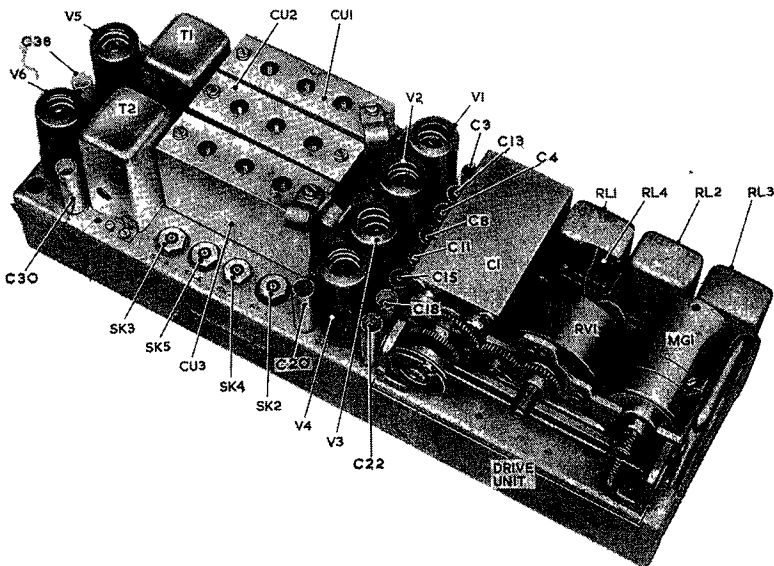

Fig. 8. Amplifying unit Type 4207 (RF unit)

Chassis assembly Type 4211 (main chassis)—
fig. 15.

These circuits cannot be described separately and reference will be made to the various diagrams as the description proceeds. The block schematic diagram in fig. 12 shows the circuit layout of the complete receiver.

Note . . .

The following references are not used in the circuit diagrams:—

Fig. 13—RF unit—C33—C34—SK1.

Fig. 14—IF unit—SK1.

Fig. 15—Chassis assembly—S4 to S8—PL2.

Aerial input to receiver

37. The received signal is applied to plug PL1 at the rear of the receiver chassis (fig. 15) and is passed to the aerial input of the RF unit via plug PL3 on the chassis assembly and socket SK5 on the RF unit (coil unit CU1—fig. 13).

Band selection

38. Coil unit CU1 provides the inductance of the first tuned RF circuit in three values corresponding to the three frequency bands of the receiver tuning range. The operative frequency band is selected by the band relays RL5/2 and RL6/2 as follows:—

(1) *Band 1* (2.8—5.2 Mc/s) RL5/2 operates, contact 5A closes and connects L1a as the coupling winding

to an inductance comprising L7, L4 and L1 in series. Contact 5B opens to remove the short circuit on L1.

(2) *Band 2* (5.2—9.7 Mc/s) Both relays in the coil unit are at rest and winding L4a is coupled to the inductance formed by L7 and L4 in series. L1 is short-circuited by contact 5B at rest.

(3) *Band 3* (9.7—18.1 Mc/s) Relay RL6/2 operates, closing contacts 6A and providing L7a as the coupling winding to the tuning inductance of L7, the other two coils L1 and L4 being shorted to earth by contacts 5B and 6B respectively. The coils L1, L4 and L7 can be adjusted by preset dust cores for trimming purposes.

39. The selected inductance for the particular frequency range is tuned by section C1A of the

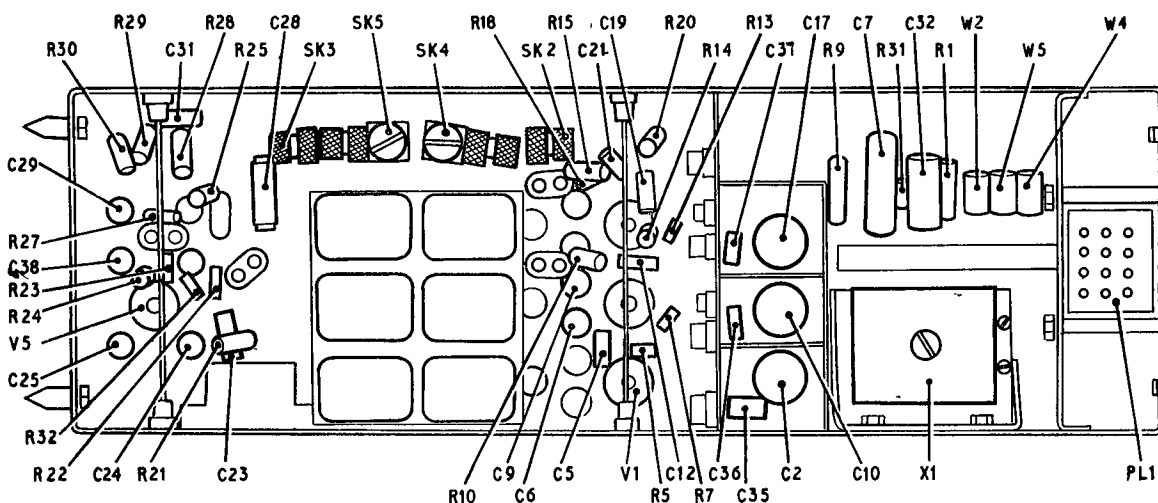

Fig. 9. RF unit—underside of chassis

RESTRICTED

motor-driven ganged capacitor. The preset capacitor C2, paralleled by C35, is the associated trimming capacitor.

Limiters

40. Across the output of the tuned circuit of coil unit CU1 is connected diode V1a. This is one diode of a CV140 and provides protection against excessive voltage from the aerial input. Conduction of the diode takes place at approximately 1 volt RMS. A standing cathode-bias from the 6.3V heater connection is obtained at the junction of potential divider R3/R4.

RF amplifiers

41. The signal input is taken via C5 to the grid of the 1st RF pentode amplifier V2. AGC voltages are fed back from the 1st IF amplifier V5 to the grid of V2 via the resistor R6.

42. Cathode-bias for V2 is developed by R7 and R31, the latter being shunted by the RF GAIN control 11RV3 in the remote control unit. The RF gain adjustment is also common to the 2nd RF amplifier V3, the connection being made at the junction of R13 and R31.

43. The anode of the 1st RF amplifier is coupled to the grid of the 2nd RF pentode by the tuned circuit formed by CU2 and the C1B section of the ganged capacitor with the trimmer C10 shunted by C36.

44. Coil unit CU2 is a three-band coil assembly operated by relays RL7/2 and RL8/2 as follows:—

- (1) *Band 1.* RL7/2 operates; contact 7A opens and provides the three coils L8, L5 and L2 in series as the tuning inductance. Each of these coils can be preset by means of an iron dust core trimmer.
- (2) *Band 2.* Both relays are at rest; contact 7A short-circuits coil L2; L5 and L8 are connected in series as the tuning inductance.
- (3) *Band 3.* Relay RL8/2 operates to close contact 8A leaving L8 as the tuning inductance; both L2 and L5 are short-circuited. Resistors R34, R35 and R36 are damping resistances across L8, L5 and L2 respectively.

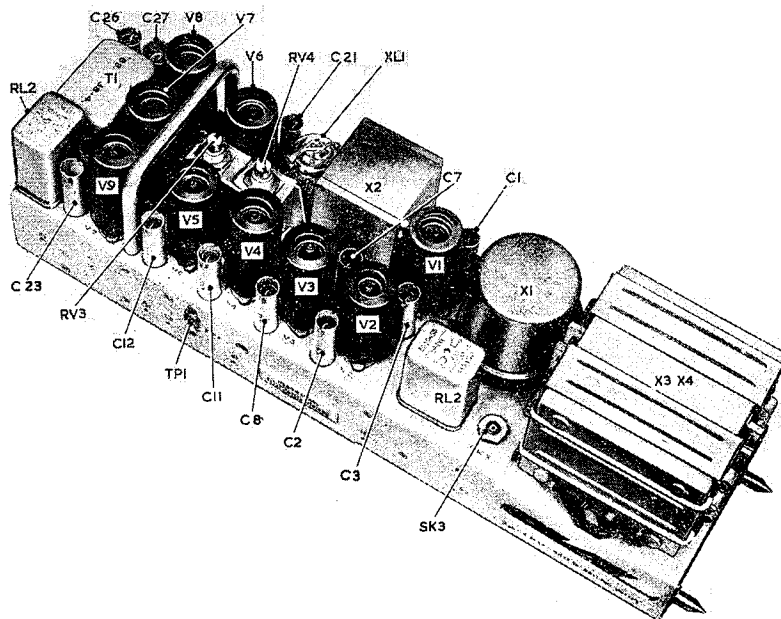

Fig. 10. Amplifying unit Type 4208 (IF unit)

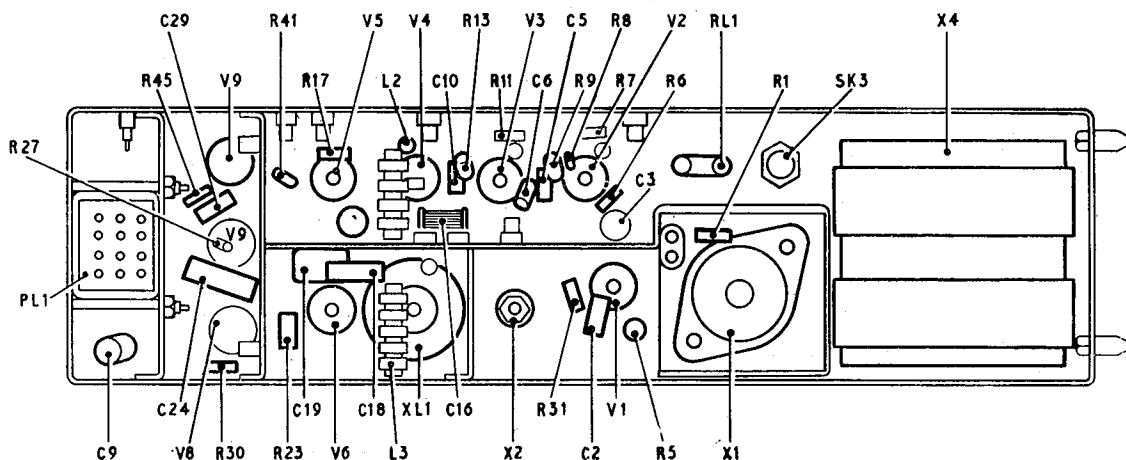

Fig. 11. IF unit—underside of chassis

RESTRICTED

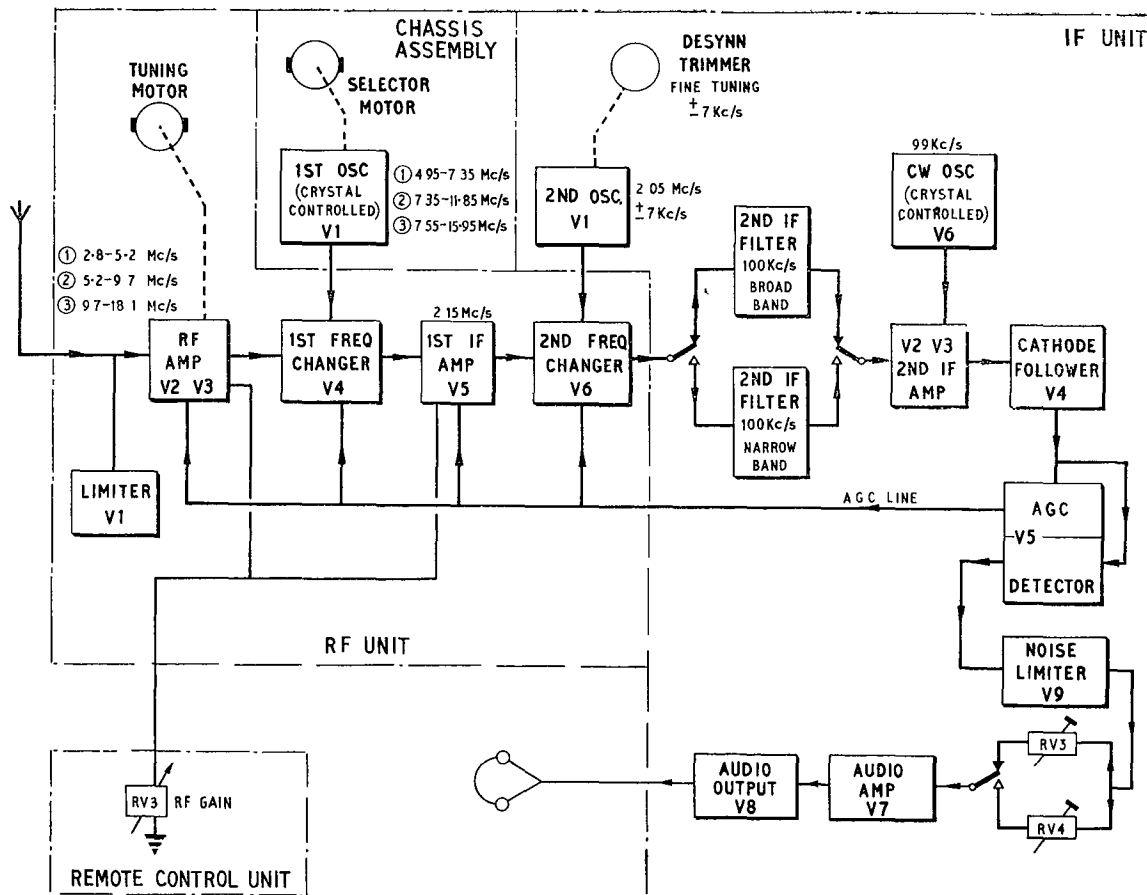

Fig. 12. Block diagram of receiver circuit

45. The anode and screen supplies for the pentodes V3 and V4 are conventionally connected to the 200-volt HT supply via pin 3 of PL1 through the dropping resistor R9. Coupling between the anode of V2 and the grid of V3 is via C12.

First frequency-changer

46. The output of V3 is coupled to the heptode 1st frequency-changer V4 by the third tuned circuit CU3 and C1C. The inductance of CUC is changed for each band by relays RL9 and RL10 operating in a similar manner to RL7 and RL8 in CU2.

47. Signal voltages from the anode of the pentagrid V3 are applied to the control grid (g3) of V4 which, in addition to the cathode-bias provided by R18 is biased from the AGC line. The screen grids (g2 and g4) and anode potentials are obtained from the 200V input in the normal way. The 1st oscillator injection from the coaxial plug 1st OSC INPUT (SK2) is applied to the 1st grid (g1) biased by R19 through C21.

48. Reference is made to the circuit diagram fig. 15. The 1st oscillator, crystal-controlled at the signal frequency plus or minus 2.15 Mc/s (para. 4), is mounted on the main chassis assembly and consists of an aperiodic Colpitts oscillator using one-half of a double-triode V1.

49. Any one of the 24 crystal units, selected by switches S1H-S1Q and contact 1A, is connected between the grid and earth of V1. Capacitor C2 provides the feedback between the cathode and grid, the oscillator being biased partly by cathode resistors R4 and R5. The oscillator is coupled by C5 to the second triode of V1 connected as a cathode-follower, the output of which is taken to PL4 and thence to RF unit. The output of the 1st oscillator has an impedance of approximately 200 ohms.

First IF amplifier

50. The intermediate frequency of 2.15 Mc/s is selected at the anode of V4 (fig. 13) by the primary of the IF transformer T1 preset by the trimmer C40. The secondary of T1 is coupled to the grid of the 1st IF amplifier V5, this is a conventional amplifier also with the grid bias controlled by the AGC line.

Second frequency-changer

51. The anode of V5 is coupled by IF transformer T2 to the control grid of the second heptode frequency-changer V6, the second oscillator injection frequency being applied to its first grid (g1) from the coaxial socket 2nd OSC INPUT (SK3). The second oscillator is at 2.05 Mc/s and is variable for

RESTRICTED

fine tuning at plus or minus 7 kc/s, thus providing this variation at the signal frequency (*para.* 52). The two IF transformers preceding this second frequency-changer have a pass-band wide enough to accommodate signals of this deviation.

52. The second oscillator is mounted on the IF unit, a circuit diagram of which is given in fig. 14. The oscillator consists of a pentode valve V1 operating as a modified Colpitts oscillator. The resonant circuit is contained in a small box X2 which obviates differential heating and in which the components are temperature compensated.

53. A small capacitor varied by a Desynn motor X1 is connected across the whole of the tuned circuit and effects the required plus or minus 7kc/s deviation. The output from the second oscillator at the anode of V1 is coupled by R4 and C2 to the 2nd frequency-changer V6 (*fig.* 13) via the 2nd OSC OUTPUT socket SK2 (*fig.* 14).

Second IF amplifier

54. The second intermediate frequency at 100 kc/s is derived from the anode of V6 (*fig.* 13) and is coupled by means of C31 via the output socket SK4 (IF OUTPUT). Here it enters the IF unit at SK3 and by means of the changeover relay contact 1A is switched to one of the two 100 kc/s filters X3 and X4.

55. These filters are composed of a number of resonant units at specified frequencies. Each consists of a toroidally wound coil on a permalloy dust core and a silver-mica condenser moulded in a block of synthetic resin. The complete filter is tropically sealed and being preset requires no further adjustment in service. Filter X3 is used on R/T, MCW or CW operation (3 kc/s 6dB down). For narrow-band CW2 operation filter X4 is used (500 c/s 6dB down).

56. The output of either of these filters is selected by the relay contact 1B and applied to the grid of V2 of a two-stage IF amplifier designed to compensate for the insertion loss of the filters. The pentode valves V2 and V3 are resistance-capacitive coupled by C5 and R9 in a conventional manner.

CW reception

57. An additional coupling to the grid of V3 is made from the 99 kc/s oscillator V6. This is a CW oscillator used in conditions of CW reception and producing a 1,000 c/s beat note on a signal that is on its nominated frequency. The preset capacitor C16 affords an adjustment of the injection level.

58. The oscillator is crystal-controlled using a 99 kc/s crystal XL1 connected in the grid circuit of V6. The connection of HT to the oscillator anode is controlled by relay RL2/2 which is energized when the equipment is in the CW condition. Contact 2A completes the 200V supply to the anode via R23 from pin 3 of PL1 (*fig.* 14).

59. A cathode-follower V4 is connected in the output of the second 100 kc/s IF amplifier V3. The

cathode load of the former consists of the 150-ohm resistor R16 with the coil L2 in series, the path to earth being completed by R21. The low impedance output from this stage is coupled to the double-diode V5 which is connected as an AGC rectifier and audio detector.

AGC circuit

60. The cathode of the AGC diode is fed with signals from the junction of R16 and L2 with R17 and C12 connected as the diode load; the AGC bias across this load is filtered by R18 and C9 and then connected via pin 8 of PL1 to those valves controlled by AGC. These are the RF amplifiers, the 1st frequency changer, the 1st IF amplifier and the 2nd frequency-changer (V2, V3, V4, V5 and V6 on the RF unit). The delay bias for the AGC rectifier is developed mainly by R21.

Audio detector

61. Input to the audio detector diode V5b is also taken from the junction R16 and L2, the detector load being the resistors R42, R41 and R39 bypassed by C13. A test point (used for alignment purposes) is connected across R39 for measurement of the potential developed by the detector current.

Noise limiting

62. Noise limiting is provided by the double-diode V9 connected in the output from the audio detector. The full audio output from V5b is filtered by R43 and C30 and applied to the anodes of V9 via R44 giving the potential proportional to the carrier level at V5.

63. Approximately half the audio signal voltage is taken from the junction of the potential divider R41, R42 and applied to the cathode of V9b, this cathode is thus held negative to its anode. In these conditions the diode conducts thus passing the audio signal to the grid of the audio amplifier stage V7 via the relay contact 2B.

64. At 100 per cent modulation the average value of the potential at the cathode of V9b rises to the same potential as the anode and the diode cuts off. This occurs whenever impulsive noise exceeds the level of 100 per cent modulation and removes the audio signal to the output stage. Should a noise pulse considerably exceed the cut-off potential of this limiter the self-capacitance of the diode still allows the signal to pass to V7. In this event the anode of V9a becomes positive with respect to its cathode, diode V9a conducts and virtually short-circuits the load (R41, R42) of V5 via V30 thus again cutting the audio output. c 30

AF amplification

65. The audio signal from V9 is coupled to the audio stage V7 by means of C29 and RV3 or C29 and RV4, according to the position of the relay contact 2B, and thence by R30, C24 to the AF output valve V8. This valve is transformer coupled to the output by T1.

66. Capacitors C14, C25 and C28 provide tone correction and negative feedback from the potential

divider R34 and R35 in the output is applied over stages V7 and V8.

67. The potentiometers RV3 and RV4 provide independent adjustment of audio level, according to the position of the relay contact 2B. Relay RL2/2 is energized in CW conditions and contact 2B selects potentiometer RV4. In conditions for R/T the relay contact selects potentiometer RV3.

Control circuits

68. This description refers mainly to the circuits of the main chassis assembly and reference should be made to the circuit in fig. 15. The receiver has only one tuning motor and this is mounted on the RF unit, the setting of the tuning motor MG1 (fig. 13) is controlled by two 12-way potentiometers POT. 1 and POT. 2 (fig. 15).

Front panel controls

69. TUNE/NORMAL switch (S2). In the NORMAL position the tuning motor circuit (MG1) on the RF unit is connected to the 19V supply via pin 3 of PL5 (fig. 15). The tuning lamp LP1 is disconnected from the 19V supply.

70. In the TUNE position the tuning motor circuit is disconnected from the 19V supply; this permits manual operation of the manual TUNE control and the associated drum tuning dial (fig. 6). The lamp LP1 is connected to the 19V supply and will glow as long as the switch is in the TUNE position. The RF GAIN control on the remote control unit is earthed via pin 2 of PL6.

71. Receiver band switches S9 and S10. These are in two banks of twelve switches, there is one switch for each channel and each switch has three positions:—

- (1) 2.8 to 5.2 Mc/s—UP position.
- (2) 5.2 to 9.7 Mc/s—MID position.
- (3) 9.7 to 18.1 Mc/s—DOWN position.

72. POT. 1/POT. 2. The two twelve-way potentiometers POT. 1 and POT. 2 can be adjusted for the selected channel by means of the 24 control knobs located on the front panel just below the band switches S9 and S10.

Motor-operated channel selection circuits

Selector switch S1

73. The selector switch S1 is driven by the selector motor MG1 (fig. 15). The function of the various sectors of the switch is described below:—

- (1) S1B is the searching bank for the channel letter connections from the remote control unit switch 6S1 (via PL7, pins 7 to 12). The method of selection of any one of twelve channels by means of six connections is described in Chap. 7.
- (2) S1A is mechanically ganged to S1B and will assume a similar angular position to the latter as the motor-driven switch-shaft rotates. Six connections from S1A are taken to the searching switch-bank in the transmitter control circuit (via PL7, pins 1 to 6).

- (3) S1C to S1F are the switch sectors selecting the particular 3-pole band switch for the selected channel. They are grouped as follows:—

Channels 1A to 1M employ S9A to S9M via S1E and S1F.

Channels 2A to 2M employ S10A to S10M via S1C and S1D.

The selection of S1E and S1F, S1C and S1D is made by the number relay RL2/2.

- (4) S1G is the “clicker” switch on the motor “stop” circuit and is associated with S1B and motor relay RL3/2.

- (5) S1H to S1Q are the crystal selection switches. These are in pairs, each selecting one of six crystals, e.g. S1Q earths all crystals except the one selected, while S1P connects that crystal via “number” relay RL1/2 (contact 1B) to the grid of the oscillator V1.

The switch sectors are connected in pairs so that the relay contact 1B selects two banks of 12 crystals as follows:—

Channels 1A to 1M employ S1H to S1L to select crystals XL1 to XL12.

Channels 2A to 2M employ S1M to S1Q to select crystals XL13 to XL24.

POT. 1/POT. 2

74. Ganged to the same shaft as S1H are the two 12-channel potentiometers shown as POT. 1 and POT. 2 in fig. 15. These are selected for channels 1A to 1M and 2A to 2M respectively, by the relay contact 1B

Relay circuits

75. The function of each relay is given below, the operation of the relays within the receiver tuning circuit is described in para. 38.

76. RL1/2 and RL2/2 are the number relays each having “changeover” contacts. In each position of the contacts twelve of the crystals, twelve of the band switches and one of the 12-way potentiometers are connected to the channel selector switches. Contact 1A selects the crystal banks; contact 1B selects either POT. 1 or POT. 2; contact 1B and 2B select the band switch sectors S1E to S1F.

77. RL3/2 is the selector motor relay. Contact 3A switches the motor on and off (shorting the armature to earth in the off position, thus providing braking). Contact 3B completes the energizing circuit of the receiver muting relay RL6/1.

78. RL4/1 is the “Receiver ON” relay and is energized when the 19V supply is applied to the receiver. Contact 4A completes the 28V supply to the receiver control circuits.

79. When the 28V is applied to the receiver control circuits, relay RL5/1 is energized. Contact 5A connects the 19V supply to the receiver control circuits.

80. RL6/1 is the receiver muting relay and is operated either by the “service” switch in the

RESTRICTED

remote control unit, the "key" circuit via pin 6 of PL6, or the motor relay RL3/2 contact 3B.

81. RL7/1 is the crystal-oven control relay and is energized via the bimetal thermal regulator X2. Contact 7A completes the 28V supply to the heater R1 in the crystal-oven (*para.* 85). The capacitors C9, C10 prevent RF leakage from the oven to the control winding.

Receiver power supply circuits

82. With the power switch 11S3 (remote control unit) in the STB/BY (receiver ON) position, the 19V supply from the aircraft battery at the PL5 pin 3 is connected through the fuse F2 to energize relay RL4/1. Contact 4A applies the 28V battery supply to the rotary transformer at TG2 and also to the remainder of the receiver control circuits requiring this supply (through fuse F3).

83. With the closing of contact 4A, relay RL5/1 is energized and contact 5A switches the 19V supply to the 19V control circuits.

84. The rotary transformer is filtered at input and output by two sections of interference filtering enclosed in a screened box X1. The fuse in X1 protects the HT filter components. The output at 200V DC through fuse F1 is smoothed by C1 and taken to the general 200V supply to the receiver circuits. The distribution is to the anode of V1 via R10, to the RF unit through SK1 pin 3 and to the IF unit through SK2 pin 3.

85. The crystal oven is heated by a resistance winding R1 mounted in the oven door. The bimetal thermal regulator X2, set at 50 deg. C nominal, is closed at normal ambient temperature and in these conditions completes the energizing circuit of relay RL7/1.

86. Contact 7A closes and completes the 28V supply to the heater resistor R1. The heating is cut-off when the thermal regulator X2 cuts off the supply to relay RL7/1. The earth return of R1 is

taken through a second regulator X3 which operates at 60 deg. C. This regulator will open if X2 fails and so prevents damage due to overheating.

Function of receiver tuning circuits when setting-up a channel

87. Assume that a channel has been selected in the 1A to 1M range and the associated adjusting knob on the potentiometer POT. 1 has been turned fully counter-clockwise.

88. The TUNE/NORMAL switch S2 is put to the TUNE position. This places the receiver at maximum RF gain and removes the motor 19V supply to the selector motor MG1 (*fig.* 15); at the same time the dial illumination lamp LP2 is connected to the 19V supply.

89. The bridge formed by POT. 1 and RV1 is unbalanced and RL4/1 operates thus closing either of the slave relays (RL1/2 or RL2/2) of the tuning motor (*fig.* 13).

90. These put an earth on the receiver mute line via PL1 pin 9, SK1 pin 9 to the TUNING lamp LP1 (*fig.* 13), thus completing the lamp circuit and causing it to glow. The muting relay RL6/1 will also be energized.

91. The receiver tuning capacitor is now tuned manually for maximum noise by the drum dial on the front panel, thus altering the setting of RV1 which is geared to the capacitor shaft. The TUNING lamp LP1 remains aglow as the bridge is still unbalanced.

92. The adjusting knob of the associated channel on POT. 1 is now turned clockwise until the bridge is balanced; relay RL4/1 then returns to its neutral position thus releasing its slave relays, removing the earth from the receiver mute line, extinguishing the TUNING lamp and indicating that the tuning setting is reached.

93. The TUNE/NORMAL switch is then reset to the position NORMAL for operation at the remote control point.

RELAYS (RND)	6A, 3, 3A, 5, 5A, 4, 6, 5B, 6B	2A, 1B	2B, 1A	C5, 6B, C4, C9, C6	7, 7A, 8, 8A	9, 9A, 10, 10A	C1B, C22, C23	C20, C24, C26	C13, C27, C25	C28, C30	C7, C31, C29
COMPONENTS	C52, C53, C35	R3, R4	R10, R10A, R10B	R11, R12, R13, R14, R15, R16, R17, R18, R19, R20, R21, R22, R23, R24, R25, R26, R27, R28, R29, R30, R31, R32, R33, R34, R35, R36, R37, R38, R39, R40, R41, R42, R43, R44, R45, R46, R47, R48, R49, R50, R51, R52, R53, R54, R55, R56, R57, R58, R59, R60, R61, R62, R63, R64, R65, R66, R67, R68, R69, R70, R71, R72, R73, R74, R75, R76, R77, R78, R79, R80, R81, R82, R83, R84, R85, R86, R87, R88, R89, R90, R91, R92, R93, R94, R95, R96, R97, R98, R99, R100	R1, R2, R3, R4, R5, R6, R7, R8, R9, R10, R11, R12, R13, R14, R15, R16, R17, R18, R19, R20, R21, R22, R23, R24, R25, R26, R27, R28, R29, R30, R31, R32, R33, R34, R35, R36, R37, R38, R39, R40, R41, R42, R43, R44, R45, R46, R47, R48, R49, R50, R51, R52, R53, R54, R55, R56, R57, R58, R59, R60, R61, R62, R63, R64, R65, R66, R67, R68, R69, R70, R71, R72, R73, R74, R75, R76, R77, R78, R79, R80, R81, R82, R83, R84, R85, R86, R87, R88, R89, R90, R91, R92, R93, R94, R95, R96, R97, R98, R99, R100	C1, C2, C3, C4, C5, C6, C7, C8, C9, C10, C11, C12, C13, C14, C15, C16, C17, C18, C19, C20, C21, C22, C23, C24, C25, C26, C27, C28, C29, C30, C31, C32, C33, C34, C35, C36, C37, C38, C39, C40, C41, C42, C43, C44, C45, C46, C47, C48, C49, C50, C51, C52, C53, C54, C55, C56, C57, C58, C59, C60, C61, C62, C63, C64, C65, C66, C67, C68, C69, C70, C71, C72, C73, C74, C75, C76, C77, C78, C79, C80, C81, C82, C83, C84, C85, C86, C87, C88, C89, C90, C91, C92, C93, C94, C95, C96, C97, C98, C99, C100	L1, L2, L3, L4, L5, L6, L7, L8, L9, L10, L11, L12, L13, L14, L15, L16, L17, L18, L19, L20, L21, L22, L23, L24, L25, L26, L27, L28, L29, L30, L31, L32, L33, L34, L35, L36, L37, L38, L39, L40, L41, L42, L43, L44, L45, L46, L47, L48, L49, L50, L51, L52, L53, L54, L55, L56, L57, L58, L59, L60, L61, L62, L63, L64, L65, L66, L67, L68, L69, L70, L71, L72, L73, L74, L75, L76, L77, L78, L79, L80, L81, L82, L83, L84, L85, L86, L87, L88, L89, L90, L91, L92, L93, L94, L95, L96, L97, L98, L99, L100	W1, W2, W3, W4, W5, W6, W7, W8, W9, W10, W11, W12, W13, W14, W15, W16, W17, W18, W19, W20, W21, W22, W23, W24, W25, W26, W27, W28, W29, W30, W31, W32, W33, W34, W35, W36, W37, W38, W39, W40, W41, W42, W43, W44, W45, W46, W47, W48, W49, W50, W51, W52, W53, W54, W55, W56, W57, W58, W59, W60, W61, W62, W63, W64, W65, W66, W67, W68, W69, W70, W71, W72, W73, W74, W75, W76, W77, W78, W79, W80, W81, W82, W83, W84, W85, W86, W87, W88, W89, W90, W91, W92, W93, W94, W95, W96, W97, W98, W99, W100	SK1, SK2, SK3, SK4, SK5		
RESISTORS	R1, R2, R3, R4, R5, R6, R7, R8, R9, R10, R11, R12, R13, R14, R15, R16, R17, R18, R19, R20, R21, R22, R23, R24, R25, R26, R27, R28, R29, R30, R31, R32, R33, R34, R35, R36, R37, R38, R39, R40, R41, R42, R43, R44, R45, R46, R47, R48, R49, R50, R51, R52, R53, R54, R55, R56, R57, R58, R59, R60, R61, R62, R63, R64, R65, R66, R67, R68, R69, R70, R71, R72, R73, R74, R75, R76, R77, R78, R79, R80, R81, R82, R83, R84, R85, R86, R87, R88, R89, R90, R91, R92, R93, R94, R95, R96, R97, R98, R99, R100										

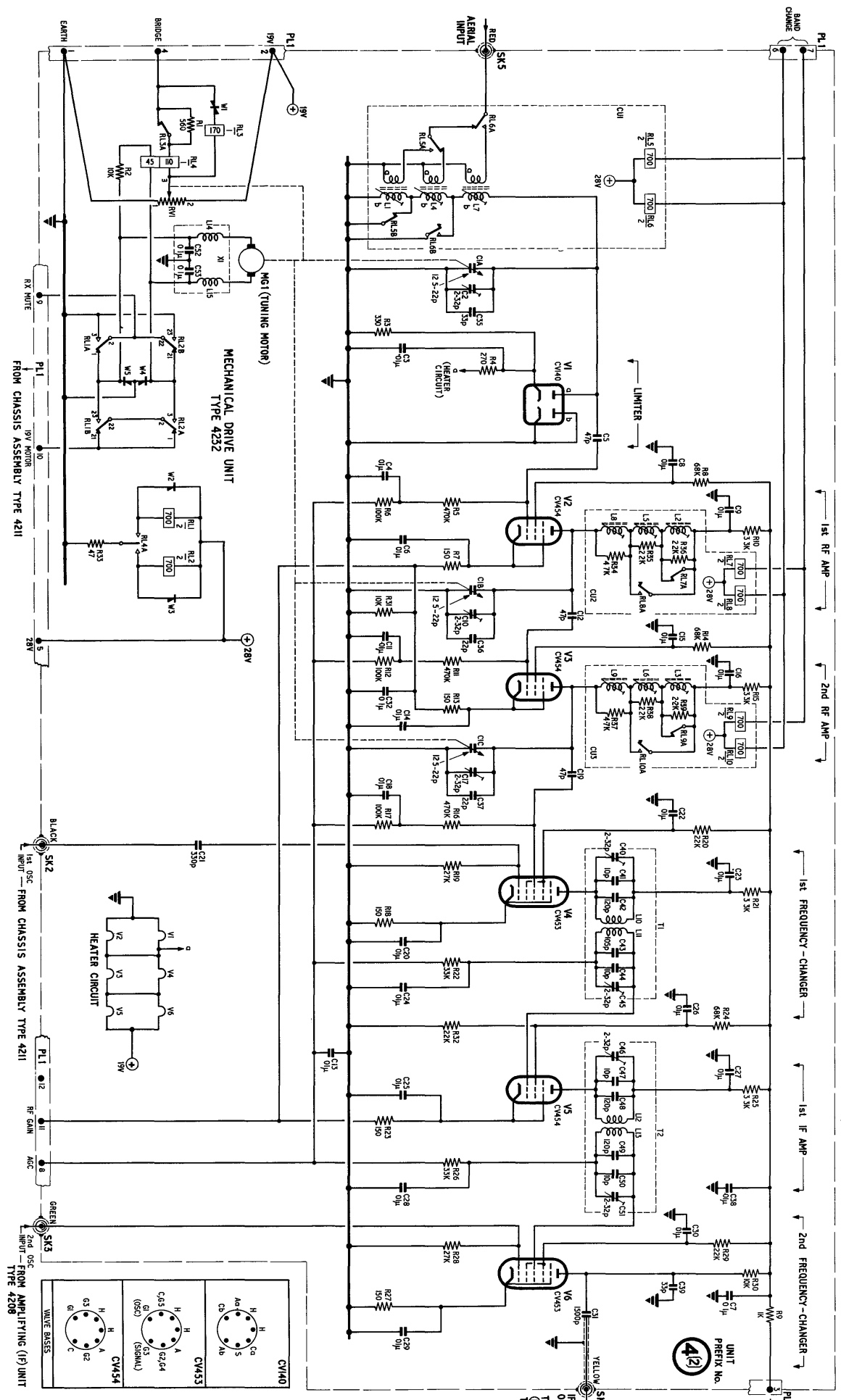

AIR DIAGRAM
6703E/MIN.
APPROVED BY INSTITUTE OF SURVIVAL
FOR REPRODUCTION BY
AIR FORCE PERSONNEL

A.R1 5874 - Amplifying unit (RF) Type 4207 - circuit (Receiver R4187)
RESTRICTED

462723 / 7318 625 11/54 88LUD Gp 979

Fig. 13
(A.L. 9, Oct 54)

COMPONENTS	C1	C2	C3	C4	C5	C6	C7	C8	C9	C10	C11	C12	C13	C14	C15	C16	C17	C18	C19	C20	C21	C22	C23	C24	C25	C26	C27	C28	C29	C30	C31	C32	C33	C34	C35
RESISTORS	R1	R2	R3	R4	R5	R6	R7	R8	R9	R10	R11	R12	R13	R14	R15	R16	R17	R18	R19	R20	R21	R22	R23	R24	R25	R26	R27	R28	R29	R30	R31	R32	R33	R34	R35

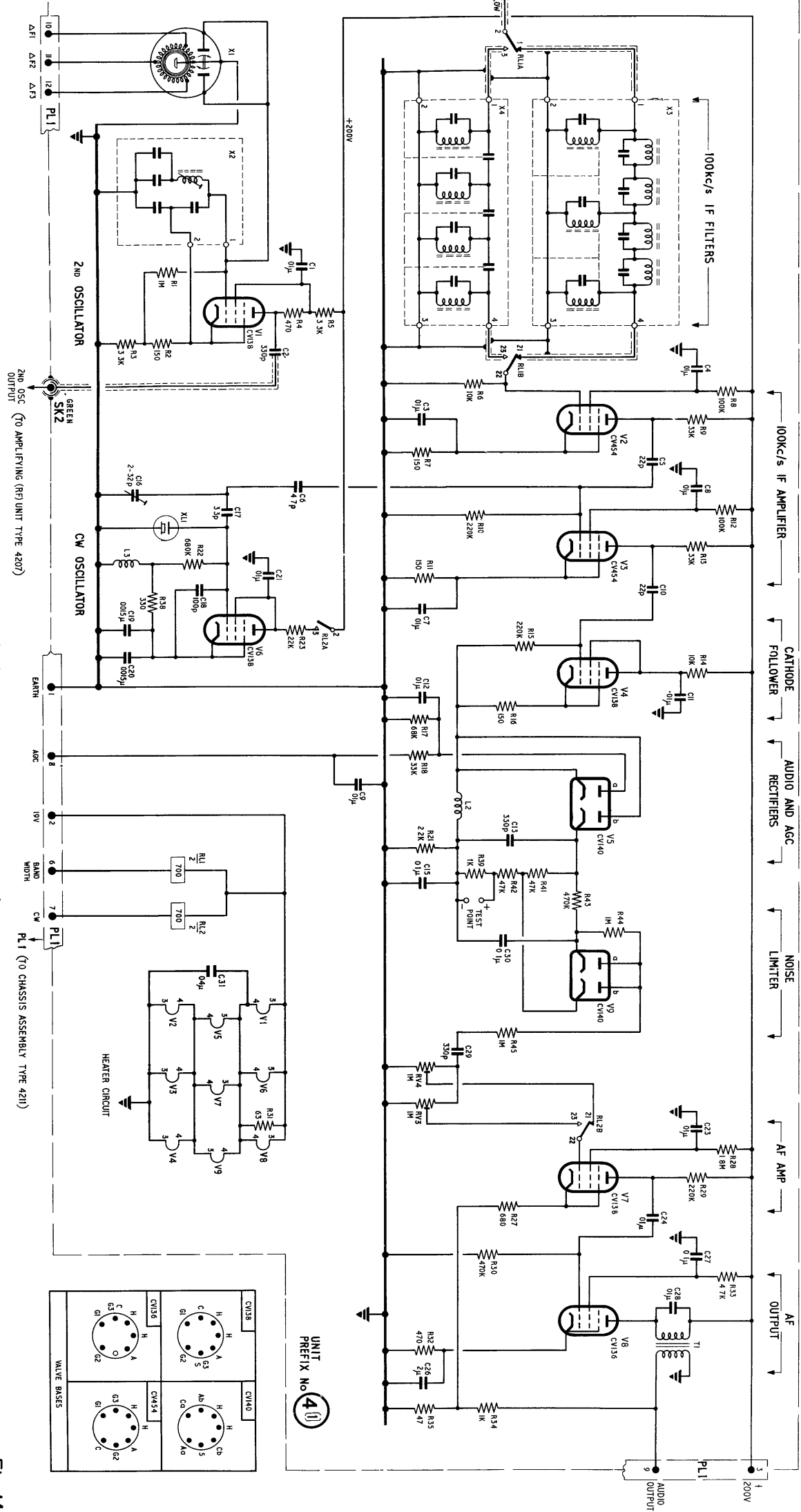

ARI.5874-Amplifying unit (I.F) Type 4208 - circuit (Receiver R4187)

RESTRICTED

Fig 14

462723 / 7318 625 11/54 881UD Gp 979

(A.L.9 Oct 54

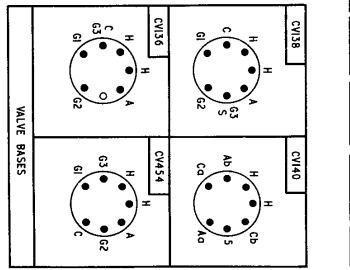

NOTE - ALL SWITCHES ARE SHOWN WITH KEYS AS SEEN ON CHANNEL X, UNLESS OTHERWISE INDICATED. CHANNEL LETTERS AS INDICATED BY ARROWS.

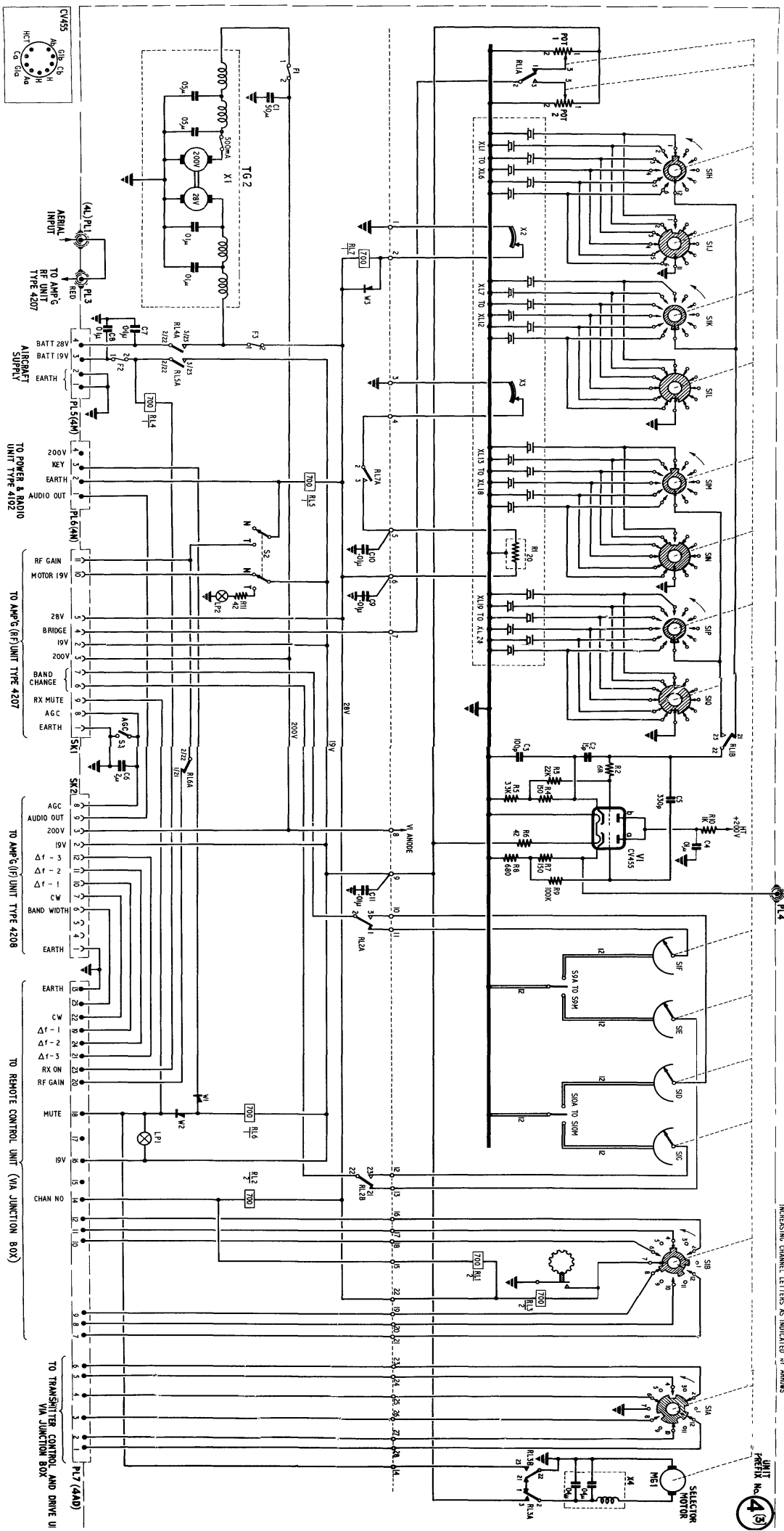

AIR DIAGRAM
6/03G/M/IN
REVISED BY A LIST OF JUNES
BY W. H. WOODRUFF
ISSUE 1

ARL5874 - Chassis assembly Type 4211 - circuit (Receiver R4187)
R E S T R I C T E D

462723 / 7318 625 11/54 884ud Gp 979

Fig. (A) 9. Oct

Chapter 3

CONTROL UNIT TYPE 4190

LIST OF CONTENTS

	Para.		Para.
<i>Introduction...</i>	1	<i>TEST/TUNE switch (S4)</i>	25
<i>Construction</i>	2	<i>Band switches (S2/1 and S2/2)</i>	26
<i>Front panel controls and switches</i>	3	<i>TUNING lamp (LPI)</i>	28
<i>Chassis layout...</i>	7		
<i>Circuit description</i>	15	<i>Selector circuit switches and relays</i>	
<i>Oscillator unit Type 4215</i>	17	<i>Selector switches (S3)</i>	29
<i>Crystal units</i>	22	<i>Relays</i>	30
<i>Control circuits</i>	23	<i>Motor relays</i>	31
<i>Front panel switches</i>		<i>Number relays</i>	34
<i> Meter switch (S1)</i>	24	<i>Aerial relay</i>	35
		<i>Safe relay</i>	39

LIST OF ILLUSTRATIONS

	Fig.
<i>Control unit Type 4190—front</i>	1
<i>Chassis with cover removed—top</i>	2
<i>Chassis with cover removed—side</i>	3
<i>Block schematic of control and drive unit</i>	4
<i>ARI.5874—Control unit Type 4190—circuit...</i>	5

INTRODUCTION

1. The control unit Type 4190 is used in aircraft installations of the ARI.5874 with suppressed aerial systems; for those aircraft fitted with ARI.5874 using fixed wire aerials, control unit Type 4243 is used, this is described in Sect. 3, Chap. 3. The control unit Type 4190 is the control and drive unit of the transmitter (when using a suppressed aerial) and includes all the control circuits for the automatic operation of the transmitter. The unit is better known as "the control and drive unit"

CONSTRUCTION

2. The chassis is constructed as a rectangular framework on which a detachable front panel is mounted. A loose dust cover is fitted and can be removed after releasing an Oddie fastener at the rear of the chassis.

Front panel controls and switches

3. An illustration of the front panel of the control

and drive unit is given in fig. 1. The panel is fitted with controls, which in conjunction with the remote control unit, can be used to set up channels on any frequency in the band without the necessity of access to the transmitter.

4. The upper half of the front panel is occupied by the channel potentiometer controls; these are part of two 12-way potentiometers (POT.1 and POT.2) described as resistance unit Type 4217. The potentiometers and associated mounting plate may be withdrawn through the front panel (Part 2).

5. Beneath the potentiometers is mounted an assembly of 24 frequency band switches used for setting up purposes. The assembly is known as switch unit Type 7289 (10F/17582) and consists of single-pole switches of the push button type. Twelve of the switch knobs are in white perspex (S2/1) and the remaining twelve in black ebonite (S2/2). The two rows of knobs are engraved A-M in each case.

6. The detachable front panel (panel, control Type 7246) may be completely disconnected from the remainder of the chassis after releasing a number of securing screws. This allows access to the front part of the chassis for servicing purposes.

Chassis layout

7. A selector motor MG1 (motor unit Type 4214) is mounted in the centre of the chassis and drives a shaft operating a multi-bank switch from which is made all the switching necessary for automatic channel selection of the transmitter circuits.

8. Three banks of the switch (S3A-B-C) associated with the control wiring are mounted at the front. Four banks, (S3E-F-G-H) at the rear and in the space between the two vertical banks of the crystal sockets, are used to select one of the 24 crystals for each channel. A further switch bank, (S3D) is used to indicate the chosen channel to the aerial selector unit of the suppressed aerial system (Sect. 2) by earthing one of 12 connections to the aerial selector unit.

9. A gear train from the same motor shaft engages with a gear train at the rear of the two 12-way potentiometers and thus turns these in unison to the selected channel position (fig. 2).

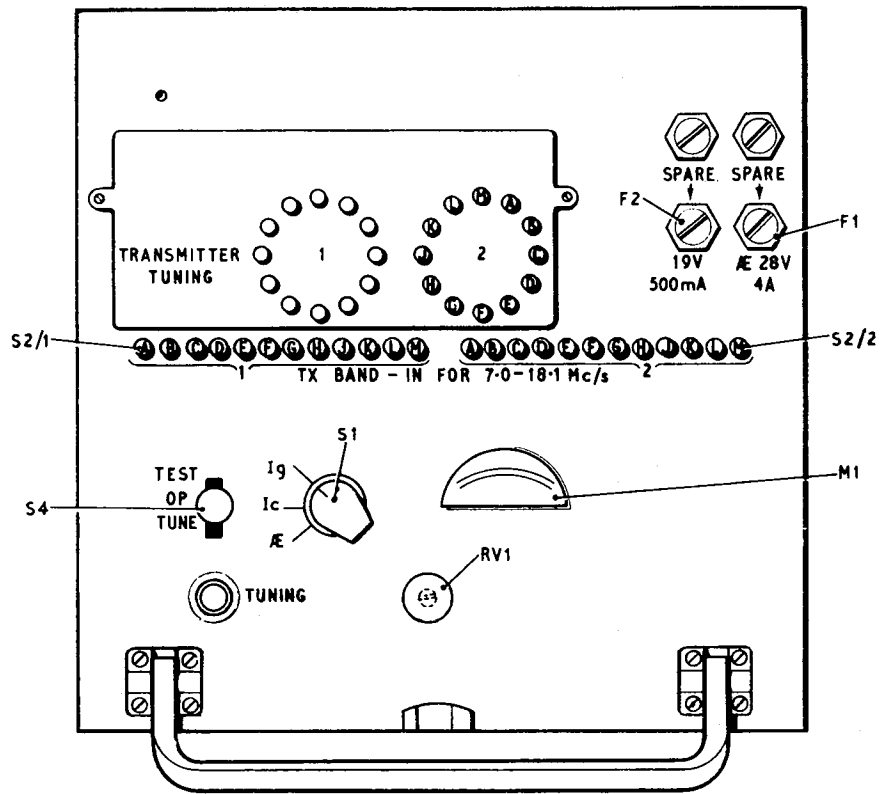

Fig. 1. Control unit Type 4190—front

10. Above the crystal sockets is mounted the small sub-chassis of the crystal oscillator (oscillator unit Type 4215), connection being made to the crystal switches by means of spring contacts.

11. Two crystal ovens, Type 13 and Type 14 (fig. 3) house the 24 crystal units which are switched in by the channel selection system and applied to the crystal oscillator circuit. The ovens are fitted with heaters and thermostatic control which keeps the crystal temperature at above 0 deg. C.

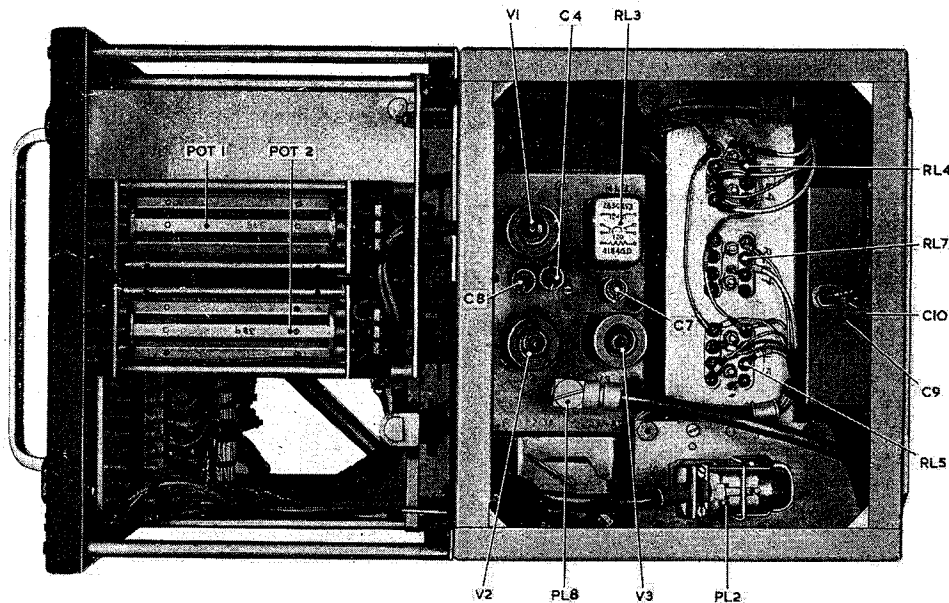

Fig. 2. Chassis with cover removed—top

RESTRICTED

12. A number of relays are fitted to the control unit chassis, one of which acts as the low impedance aerial changeover relay. The latter is mounted on a panel at the rear of the chassis and is designated relay unit Type 4216. Three coaxial plugs are connected to this relay, thus enabling the aerial to be connected through the relay to either the transmitter or the receiver (*para.* 14).

13. On the back panel of the unit are mounted plugs and sockets for interconnection with other units of the installation, the connections are made through the back-plate of the control and drive unit. (*Chap.* 10).

14. The back-plate is interconnected to the remainder of the installation by means of connectors permanently wired to the back-plates of other units of the installation. Some details of the plugs and sockets at the rear of the control and drive units are given below ; a more complete account is given in *Chap.* 10.

- (1C) PL5—coaxial plug Aerial connection to transmitter.
- (1AG) PL6—coaxial plug Connection from aerial to aerial-changeover relay (*para.* 12).
- (1L) PL7—coaxial plug Aerial connection to receiver.

Note . . .

The references in brackets refer to the back-plate and connector coding (*Chap.* 10).

CIRCUIT DESCRIPTION

15. The circuit of the control unit Type 4190 includes those parts of the transmitting circuit controlling the signal frequency and channel selection. The control unit also includes the channel letter switch controlling the channel selection of the associated aerial system. (*Sect.* 2 and 3).

16. A complete circuit diagram is given in *fig.* 5. The circuit can be divided into four parts three of which are indicated in the block schematic *fig.* 4.

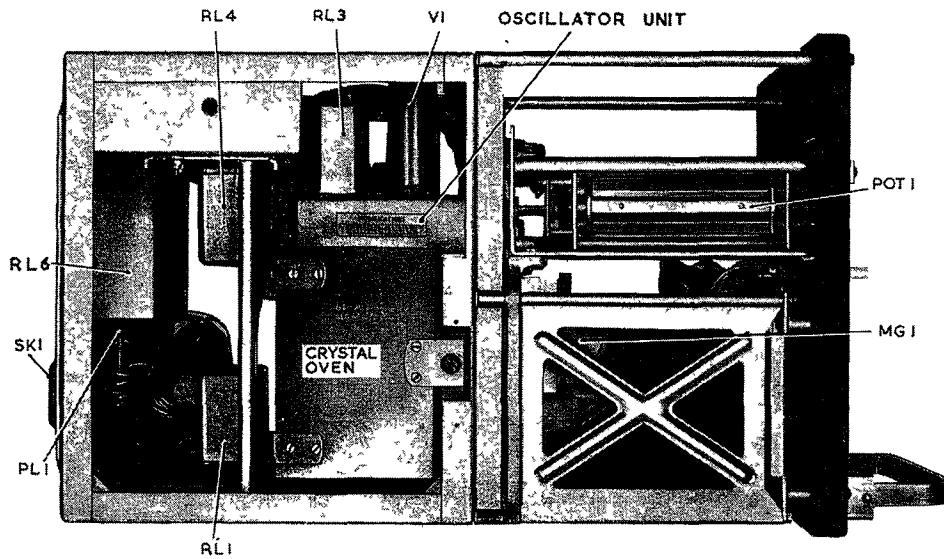

Fig. 3. Chassis with cover removed—side

- (1AF) SK1—28-pole socket Channel selections control to aerial selector unit.
- (1AE) PL1—28-pole plug Connections to remote control unit.
- (1A) PL3—20-pole plug Control and power supplies from power and radio unit.
- (1B) PL4—coaxial plug Crystal oscillator output to transmitter.

- (1) The crystal-controlled oscillator
- (2) The channel selector motor and channel selection circuits.
- (3) The transmitter metering circuits (*fig.* 5).
- (4) The aerial system channel selector switch.

Oscillator unit Type 4215

17. The oscillator unit Type 4215 includes three HF pentodes CV138. The oscillator V1 is triode-connected in an aperiodic Colpitts oscillator with feedback provided by the capacitors C1 and C2.

18. Any one of the 24 crystals can be selected for connection between grid and earth of V1, the selection being made as follows. The crystals are in two banks of twelve; those for the channels 1A—1M are selected by switch wafers S3E and S3F with S3E earthing all crystals with the exception of the one selected; S3F makes contact only with the crystal selected.

19. Switch wafers S3G and S3H operate similarly on the other crystal bank. Contact 3A of relay RL3/2 connects the oscillator grid to one or other of the crystal banks, the bank not in use being earthed by contact 3B.

20. The anode of V1 is coupled by C5 and R7 to the grids of the valves V2 and V3 connected in parallel and as a cathode-follower with load R11. The output through C6 is taken to plug PL4 at the rear of the control unit Type 4190 via SK3 on the oscillator chassis and is a nominal 2 volts RMS into a cable of 70 ohms impedance.

21. The valve heaters are connected in series with the 19V supply via PL9 and SK4 pin 1. The 300V supply to the anodes is connected via PL9 and SK4 and obtained from the keying relay 2RL4/2 in the transmitter unit (via relay 3RL1/2 in the power and radio unit).

Crystal units

22. Each bank of 12 crystal units is plugged into an enclosure which is thermostatically controlled to a temperature above 10 deg. C (nominal) by means of heaters. The heaters R15 and R16 are switched by the bimetal regulator. Regulator X3 will operate in the event of failure of X2. The heaters R17, R18 and the bimetal regulators X4 and X5 are the corresponding components in the second heated enclosure.

Control circuits

23. A full description of the channel selection and control circuits is given in Chap. 7, but a brief description of the control and switching circuits of the transmitter is given below:—

Front panel switches

Meter switch (S1)

24. The meter M1 is connected so that it may be switched to measure the grid current of the transmitter P.A. stage (Ig), the cathode current of the P.A. stage (Ic) and the aerial excitation (AE) from the metering circuit of the aerial system in use.

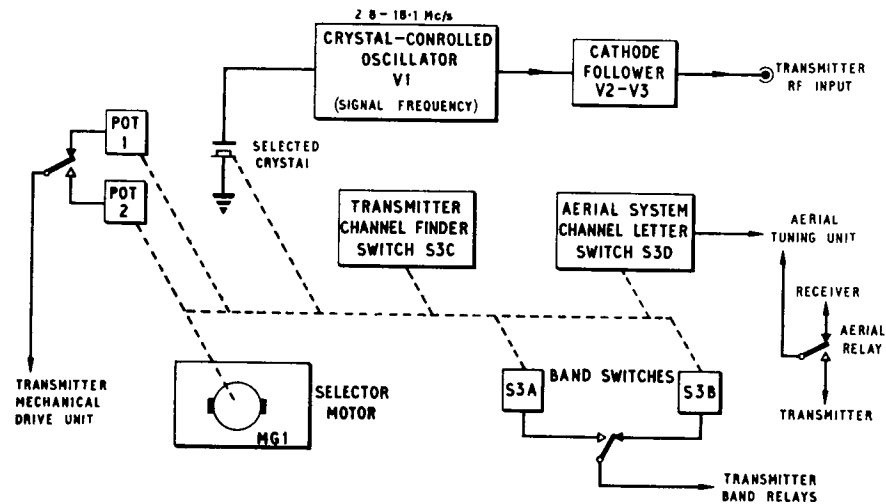

Fig. 4. Block schematic of control and drive unit

TEST/TUNE switch (S4)

25. This is a spring-loaded key switch which normally rests in the centre position. The circuit for the three positions is as follows:—

OPERATE (Centre) The "low power" line is open-circuited (S4D).

The "SAFE" line is open-circuited (S4D).

The "KEY" line is open-circuited (S4B).

TUNE (up)

The "KEY" line is earthed and the aerial changeover relay RL6/2 energized (S4B). The transmitter is switched to R/T by removing the earth from 3RL3 in the power and radio unit (S4E).

The "SAFE" relay RL7 is earthed (S4D) and removes the 19V supply from the INTERTUNE line to allow the transmitter to be adjusted (S4A).

Contact 7B removes the earth from the low power line (PL3/20) and allows tuning under "safe" power conditions only, i.e. at nearly full power.

TEST (down)

The earth is removed from the low power line.

The "key" line is earthed (S4C): this allows normal "key down" operation.

Band switches (S2/1 and S2/2)

26. The band switches are selected one per channel by means of the motor-operated switched S3B and S3A respectively. The two groups of switches S2/1 and S2/2 are selected by relay contact 4A and 4B.

27. When the band switches are in the OUT position they switch the 28V supply to the band change relays 2RL1/1, 2RL2/1 and 2RL3/1, thus changing the transmitter tuned circuits from the 7 to 18 Mc/s range to the 2.8 to 7 Mc/s range. (Chap. 4).

RESTRICTED

TUNING lamp (LP1)

28. The TUNING lamp commences to glow when the TUNE line is earthed, i.e. whenever one of the tuning motors of the transmitter or receiver operates. It is permanently on when the transmitter is switched for MANUAL operation, and serves as a reminder should the transmitter be left in the MANUAL condition after setting up.

Selector circuit switches and relays*Selector switches (S3)***29.**

S3A-B As already stated these select the individual band switches of the groups S2/1 and S2/2.

S3C This is the searching bank when the channel is being chosen at the remote control unit. Six wires run from this switch sector to the channel letter pins 1 to 6 on PL1 and thence to the receiver, "Wire saving" switch banks are used. The method of selection of twelve channels on each band is explained in Chap. 7.

S3D This 12-way switch sector passes out the selected channel information to the aerial system by earthing one of the twelve wires connected to SK1.

S3J This is a cam-operated clicker switch associated with the channel selector switch S3D; its operation is explained in Chap. 7.

S3E-H These select the crystal unit for the channel required.

Relays

30. The relays are grouped by function as follows:—

- (1) Motor relays—RL1/2 and RL2/2
- (2) Number relays—RL3/2, RL4/2 and RL5/2
- (3) Aerial relay—RL6/2 (low-impedance send-receive aerial switching).
- (4) Low power relay RL7/2 (SAFE)

Motor relays

31. When power is first applied to the control and drive unit, the relays RL1/2 and RL2/2 are energized owing to the earth provided by the connection to S3C or S3J.

32. The motor MG1 starts when 19V is connected via relay contact 1A and rotates until the unearthed position on S3C is reached ("checked" by clicker

switch S3J). Relays RL1/2 and RL2/2 then release, thus interrupting the motor circuit (contact 1B), and at the same time, removing the earth from the tune line (contact 1B).

33. Relay contact 2B makes and switches the 19V supply to the tuning head of the transmitter, this prevents the tuning head from hunting during the rotation of the selector switch S3.

Number relays

34. The number relays operate when position 2 of the number switch is chosen. Contacts 4A and 4B operate and select the group of band switches S2/2. Relay contact 5A changes control of the transmitter from POT 1 to POT 2. Contact 5B relays the number position to the selector unit of the aerial coupling unit. Contacts 3A and 3B change over the crystal groups.

Aerial relay

35. The aerial relay RL6/2 is mounted in a fully-screened box on the rear panel of the control unit (relay unit Type 4216). Its function is that of an aerial changeover switch. The supply to the relay coil is filtered by means of L1, C9 and L2, C10.

36. If the low impedance mode of aerial switching is not required for use, the links on TSB at the rear of the unit between TSB1 and TSB2 and 4 should be removed.

37. The low impedance feeder from the aerial system enter at PL6 and on "space" conditions, contact 6A puts this to the receiver via PL7.

38. On "mark" the aerial is switched by contact 6A to the transmitter output which is connected to PL5; at the same time the receiver aerial is earthed by means of contact 6B.

Safe relay

39. The "safe" relay RL7 is operated by a "key" in the aerial selector unit of the suppressed aerial system. When the "key" is pressed an earth is put on point SK1/20.

40. Contact 7B opens to give "safe" operation and contact 7A closes the key line and places the transmitter on "mark".

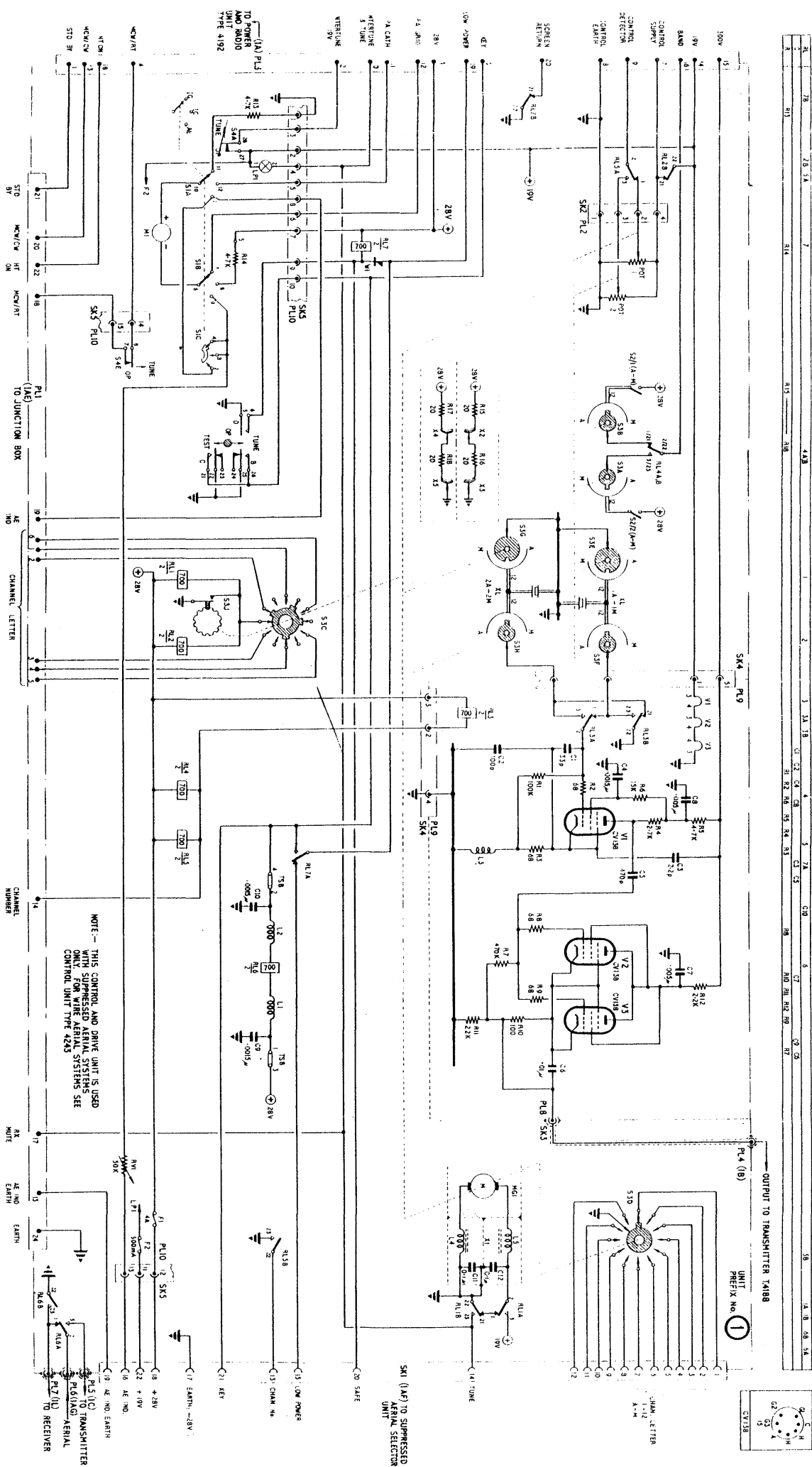

ARI. 5874 - Control unit Type 4190-circuit

RESTRICTED

Fig 5

(A.L. 7, Sec. 5d)

AIR DIAGRAM
61C30/MIN

D-2006 47997 S.W. 345

NOTE - THIS CONTROL AND DRIVE UNIT IS USED WITH SUPPRESSED AERIAL SYSTEMS SEE ONLY FOR WIRE AERIAL SYSTEMS SEE CONTROL UNIT TYPE 4285

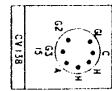

5Y3

UNIT PREFIX No. 1

OUTPUT TO TRANSMITTER T4188

SK1 (1A7) TO SUPPRESSED AERIAL SELECTOR UNIT

CHAM. SELECTOR A-74

NOTE - THIS CONTROL AND DRIVE UNIT IS USED WITH SUPPRESSED AERIAL SYSTEMS SEE ONLY FOR WIRE AERIAL SYSTEMS SEE CONTROL UNIT TYPE 4285

Chapter 4

TRANSMITTER TYPE T.4188

LIST OF CONTENTS

	Para.		Para.
Introduction	1	Band changing	26
<i>General description</i>		Keying circuit	28
Construction	5	Valve heaters	31
Front panel	13	Time delay relay	32
Interconnection of ARI.5874	14	<i>Function of front panel controls</i>	
<i>Circuit description</i>		TUNE-KEY—S1	33
RF circuits	16	METER SWITCH—S2	34
Buffer amplifiers	18	AUTO/MANUAL switch—S3	35
Power amplifier	21	Calibrated frequency dial	37
P.A. valves (CV2519)	24	Meter—M1	38
RF output	25	Drive unit mechanical Type 4212	39

LIST OF ILLUSTRATIONS

	Fig.		Fig.
Front panel of transmitter Type T.4188	1	CV 2519 connections	5
Top of transmitter chassis	2	Left side of transmitter chassis	6
Underside of transmitter chassis	3	ARI.5874—Transmitter Type T.4188—circuit	7
Block diagram of transmitter circuit	4		

INTRODUCTION

1. The transmitter RF circuit consists of a power amplifier incorporating two paralleled beam tetrodes operating in Class C, and two buffer amplifiers. The coil unit tuning the three stages is driven by a mechanical drive unit incorporating a tuning motor controlled by a bridge circuit.

2. The transmitter can be set to any of 24 frequencies (in two frequency bands) by inserting crystals of the required operating frequencies into the associated control and drive unit. The equipment is then tuned from the control and drive unit in conjunction with controls on the remote control unit (*Chap. 7*).

3. These tuning positions, when set up, may be re-selected at the remote control unit as required. Thus only the control and drive unit need be accessible for setting-up purposes.

4. The following transmitter controls are available on the front panel of the control and drive unit. (Control unit Type 4190 or Type 4243).

(1) The setting potentiometers POT. 1 and POT. 2 for the transmitter unit (and additional potentiometers for the wire aerial coupling unit when used—Sect. 3).

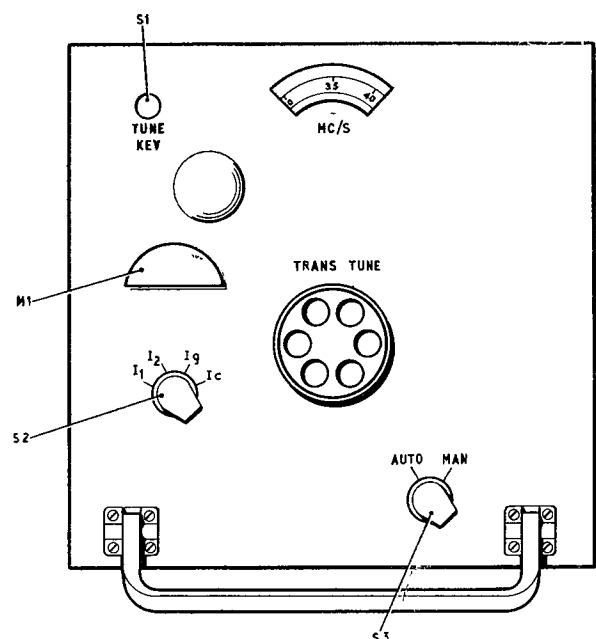

Fig. 1. Front panel of transmitter Type T.4188

(2) The meter and meter switch. The readings are P.A. grid and cathode currents, and aerial excitation.

(3) A TEST/TUNE key is used in setting-up the transmitter.

GENERAL DESCRIPTION

Construction

5. The complete transmitter consists of a composite chassis on which is mounted a front panel measuring 8 in. by 8 in. and bearing the controls necessary for the manual checking of the transmitter circuits (fig. 1).

6. A removable dust cover is fitted over the whole unit and is fixed by a quick release fastener at the rear of the unit. The depth of the unit is 12½ in.

7. The sub-units of the transmitter are mounted on the main chassis assembly Type 4210; this is a cast aluminium chassis to which is attached the front panel of the transmitter. Incorporated in the cast aluminium chassis are the mountings for the P.A. valves and the buffer amplifier valves (fig. 2). The mounting for the P.A. valves is a separate cast aluminium chassis which plugs into the main chassis.

8. At the side of the chassis assembly is bolted the coil unit or tuning unit Type 4218. This is a cast chassis on which is mounted the three variable coils tuning the amplifier stages. The coils are ganged by means of a shaft running under the centre-line of the coils below the chassis and having a chain sprocket wheel on the front panel end.

9. The drive unit mechanical Type 4212 is bolted to the right-hand front of the chassis assembly Type 4210. The drive unit includes the tuning motor with its associated gears and the potentiometer and relays that constitute the remote tuning head. Connection is made between the drive unit and the drive shaft of the coil unit by means of a silver-nickel chain running on special sprocket wheels

10. From the front of the main chassis assembly behind the drive unit are mounted the input valve V1 and the time delay relay RL10/1 mounted on a valve base (fig. 2). Underneath RL10/1 are the two relays, RL4/2 and RL5/2 and on the raised step to the rear of the relays is mounted the driver valve V2.

11. Behind the screen are the two valves of the P.A. stage, these are mounted on a raised cast box which leads the air blast from below through the valve anodes. The box is directly above the air blower MG2, attached to the underside of the chassis (fig. 3), which draws the cooling air through the air filter to discharge it directly into the box.

12. The air blower, the valve box, the filter housing and the three main units may all be separated with the aid of a screwdriver. All electrical connections are made by plugs and sockets.

Front panel

13. The front panel is illustrated in fig. 1. The function of the controls is described in para. 33 to 38.

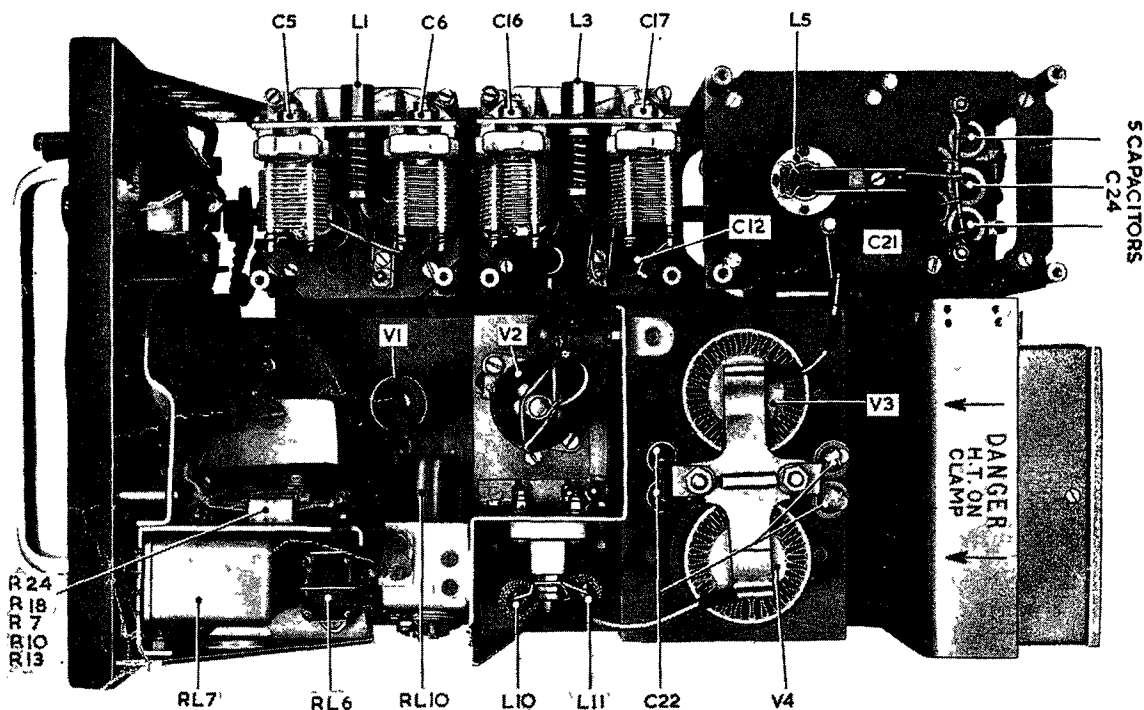

Fig. 2. Top of transmitter chassis

RESTRICTED

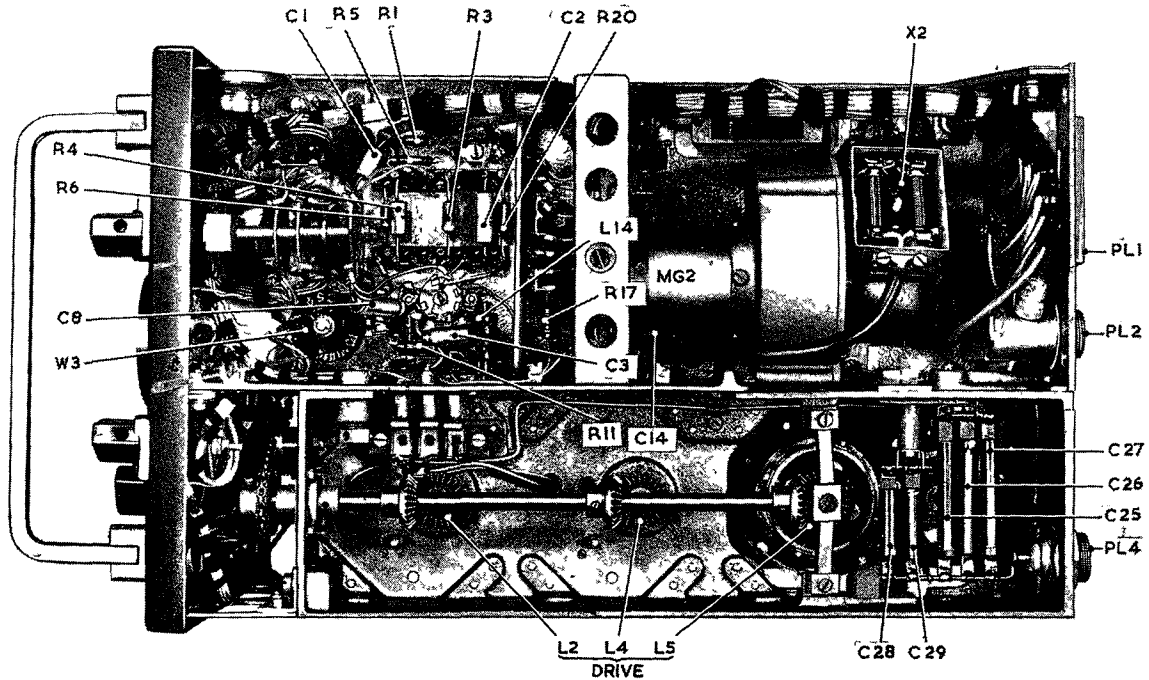

Fig. 3. Underside of transmitter chassis

Interconnection in ARI.5874

14. The interconnection of the transmitter Type T.4188 within the installation is made by one multipole and three coaxial plugs fixed to the rear face of the chassis. In common with other units of the installation these plugs connect directly into a back-plate at the rear of the transmitter mounting assembly (*Chap* 10).

15. The back-plate is interconnected to the remainder of the installation by means of connectors permanently wired to the back-plates of other

units of the installation. Some details of the plugs at the rear of the transmitter are given below ; a more complete account of these, the back-plates and the connectors is given in *Chap* 10.

- (2D) PL1 28-pole plug Control and power supplies
- (2B) PL2 Coaxial plug RF input
- (2E) PL3 Coaxial plug 600V MOD. HT
- (2C) PL4 Coaxial plug RF output

Note . . .

The references in parenthesis are the back-plate codings for the associated sockets

CIRCUIT DESCRIPTION

RF circuits

16. The function of the transmitter unit as a whole is to amplify the output from the oscillator in the control unit Type 4190 (or Type 4243—Sect. 3) This raises the input level from 2 volts RMS (nominal) into 70 ohms to the output level of 100 watts into 70 ohms at fundamental frequency.

17. A circuit diagram of the transmitter is given in fig. 7, this is simplified

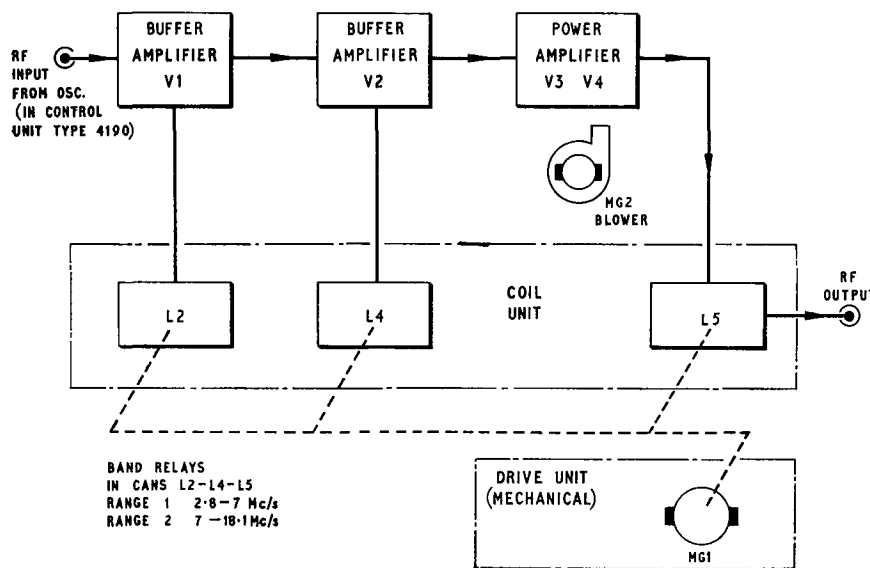

Fig. 4. Block diagram of transmitter circuit

in the block diagram (fig. 4). The input from the coaxial plug PL2 through C1 and R3 is connected to the grid of the input pentode V1; the 82-ohm resistor R1 is the terminating resistance of the input cable.

Buffer amplifiers

18. The 300-volt HT supply is connected to the screen of V1 through resistors R11 decoupled by C8; the anode is shunt-fed by choke L14. The tuned anode circuit is isolated by C3 and consists of the variable inductor L2 tuned by the preset C6 and stray capacitance. Trimming is by the use of the iron-cored coil L1 and C6. The valve is cathode-biased by R4 and R5; resistor R8 is a damping resistor connected across L1 and L2.

19. Coupling to the buffer stage is by C9 and R15 to the grid of the beam tetrode V2. The 300-volt HT supply is taken to the screen grid by R16, C11 and to the anode by shunt feed through R14 and L6.

20. The valve operates in Class AB and is biased by grid leak R15 and cathode resistors R22 and R23. The anode is tuned in a similar manner to the preceding stage by L4 and C17, and is trimmed by L3 and C17.

Power amplifier

21. The power amplifier stage has two air-blast cooled beam tetrodes V3 and V4 operating in parallel in Class C. The grids are driven from the driver stage through C13. The screen grid potential and the anode potential are obtained from the power and radio unit Type 4192 from the 300V and 600V supplies, respectively.

22. When the transmitter is modulated in the R/T and MCW conditions the anode and screen grid supplies are modulated by the output transformer 3T3 in that unit. The screen potential is taken through resistors R30 and R31 and decoupled by C20. In "SAFE" conditions the screen potential is further reduced by the introduction of the dropping resistor 3R43 switched in by relay 3RL11 (Chap 5)

23. The anodes of V3 and V4 are shunt-fed by the chokes L10-L13 connected in series-parallel. The grid circuits include the anti-parasitic chokes L7 and L8. The grid bias supply to the stage is a combination of fixed bias from the 28-volt battery supply to which the cathode return is connected; grid-leak bias through L9 and R27, R24 and cathode-bias from resistors R25 and R26 in parallel.

P.A. valves (CV2519)

24. A special type of valve is used in the P.A. stage. Details of the valve and its connections are given in fig. 5 and fig. 7.

RF output

25. The anode circuit is matched to the low-impedance output by means of the pi-circuit C22, L5 and C25, C26, C27. The coil L5 is variable and ganged to the preceding stages.

Band changing

26. To cover the frequency range the transmitter has two bands, 2.8 to 7 Mc/s and 7 to 18 Mc/s. The transmitter circuits are arranged to be normally on the higher of these bands, but the band change relays RL1/3, RL2/2 and RL3/2, when operated, switch in capacitors at the three tuning stages and thus switch the transmitter to the lower band.

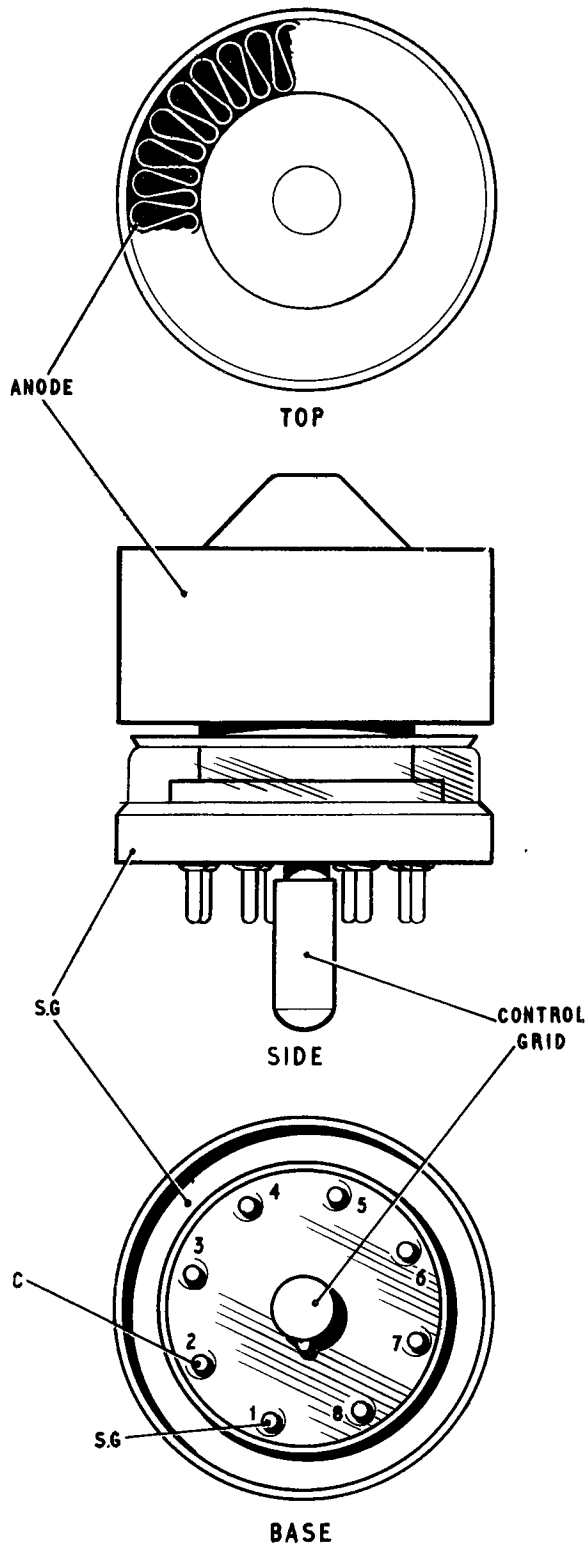

Fig. 5. CV 2519 connections

RESTRICTED

27. These capacitors are switched in by the following relay contacts :—

(1) Anode of V1. Relay contact 3B switches in capacitor C4 and trimmer C5.

(2) Anode of V2. Relay contact 2B switches in capacitors C15, C35 and trimmer C16.

(3) Output circuit. The input and output shunt elements of the pi-circuit are increased by the addition of capacitors C24 (relay contact 1A) and C28, C29 (relay contact 1B). Relay RL1/3 is a special high voltage type for band changing in the P.A. stage (*fig. 6*).

Valve heaters

31. The heaters of V2, the coil of relay RL10/1 and the heater of V1 are connected in series with the 19V supply from pin 27 of PL1; the resistor R19 is in parallel with the heater of V1. The heaters of the P.A. valves V3 and V4 are series connected to a nominal 12V supply obtained from the series dropping resistor 3R41 in the power and radio unit Type 4192 (*Chap. 5*). The blower motor MG2 is directly connected to the 28V supply via pin 11 of PL1 and starts up at the same time as the heaters are connected.

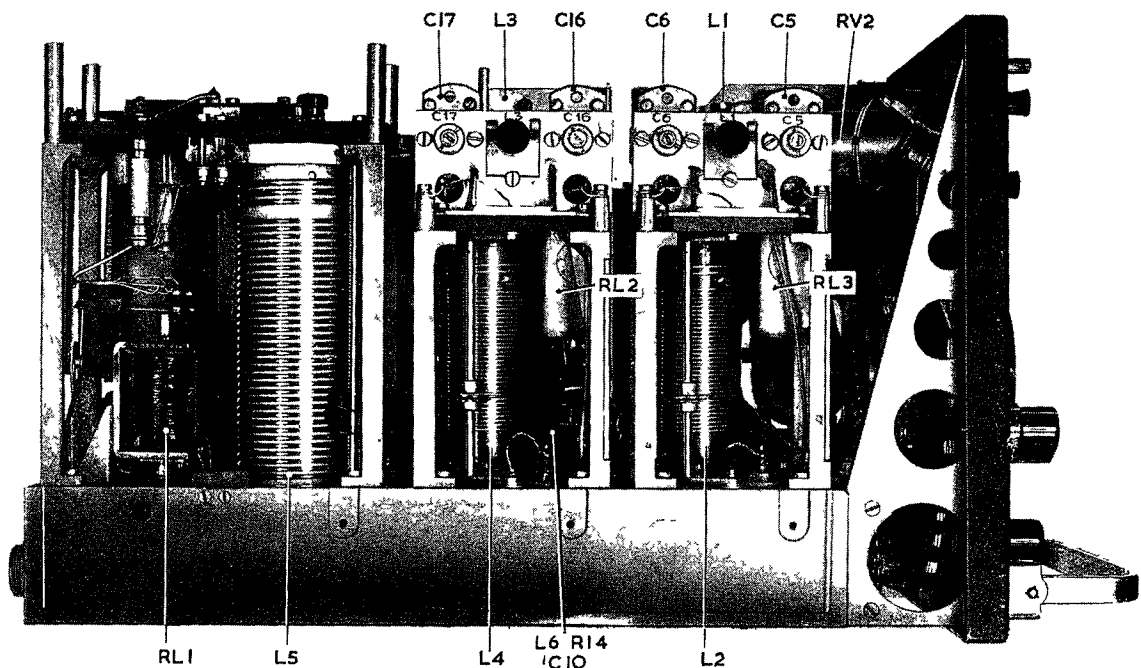

Fig. 6. Left side of transmitter chassis

Keying circuit

28. When the key line is earthed (this can be achieved by use of the TUNE KEY switch S1—*fig. 1*) the relay RL4/2 is energized; the contact 4A closes and connects the 300-volt DC supply to the first two stages of the transmitter. At the same time contact 4A also connects this supply via pin 17 of PL1 to the crystal oscillator in the control unit Type 4190 (via 3SK1 and 3SK2—*Chap. 3*).

29. The P.A. stage of the transmitter is normally biased *nearly* to cut-off by the cathode resistor R13 but when contact 4B closes R13 is short-circuited and the P.A. stage is then able to operate normally.

30. When the intertune line is earthed relay RL5/2 is energized and the contacts 5A and 5B reverse the conditions created by the operation of relay RL4/2 (*para. 28 and 29*) and put the transmitter in the "space" condition.

Time delay relay

32. The thermal relay RL10/1 is connected in parallel with the resistor R20 and with a time delay of 30 seconds after switching on the heaters the relay closes contact 10A allowing HT to be applied to the transmitter.

Function of front panel controls

TUNE KEY—S1

33. When the tune key is pressed the transmitter is in the "mark" condition for tuning purposes.

METER SWITCH S2

34. The meter switch has four positions marked I₁, I₂, I_g, and I_c.

(1) In the I₁ position the meter reads the cathode current of valve V1. The meter M1 is connected across R5 to earth so that the meter reads the

cathode current of this stage through R6. (Meter reading X10 = cathode current in milliamps).

(2) In the I_2 position the meter reads the cathode current of valve V2. The meter M1 is connected across R23 to earth so that the meter reads the cathode current of this stage through R21. (Meter reading X20 = cathode current in milliamps).

(3) In the I_g position the meter reads the grid current of the P.A. stage. The meter M1 is connected across R24 to earth so that the meter reads the grid current of this stage through R18. (Meter reading X10 = grid current in milliamps).

(4) In the I_c position the meter reads the cathode current of the P.A. stage. The meter M1 is connected across R7 to the 28V supply in the cathode lead of the P.A. stage so that the meter reads the cathode current of this stage through R10. (Meter reading X100 = cathode current in milliamps). This can be used to check the transmitter by pressing the TUNE KEY switch S1 when S3 is in the AUTO position.

AUTO/MANUAL SWITCH (S3)

AUTO position

35. The AUTO position is used for the normal operation of the equipment.

(1) In the AUTO position the switch connects the control detector circuit from pin 14 of PL1 to the detector contact on the potentiometer RV2 of the transmitter remote control head. The connection within the transmitter is made via SK2 and PL6, pin 2.

(2) Additionally, the HT ON circuit is connected between pins 8 and 4 on PL1 facilitating remote control of HT. This circuit may be interrupted by relay contact 10A (*para.* 32).

(3) In the AUTO position the tuning motor MG1 is mechanically engaged with the coil drives.

MANUAL position

36. The MANUAL position is used in bench testing and for checking the bridge resetting when the equipment is in use. In the MANUAL position the circuit is affected as follows:—

(1) The HT ON circuit is opened to prevent manual operation with the HT applied.

(2) The bridge circuit is disconnected to prevent operation on MANUAL.

(3) The motor drive from MG1 is disconnected to allow the mechanism to be turned manually by means of the finger dial on the front of the transmitter.

Calibrated frequency dial

37. The front panel also displays a dial calibrated in the two frequency bands and ganged to the tuning circuits. This is used to check the tuning position against harmonic operation.

Meter—M1

38. The meter on the front panel is a microammeter 0–500. The scale reading is 0 — 5 with a f.s.d. of 500 microamps. Its resistance is 180 ohms. The actual readings are in milliamps and the multiples are indicated in *para.* 34.

Drive unit mechanical Type 4212

39. The drive unit mechanical Type 4212 is the remote tuning head connected to the transmitter proper by means of the plug and socket PL6 and SK2, it is also mechanically connected by the sprocket chain and lever to switch S3. The operation of the remote control circuit is fully described in *Chap.* 2.

IC	10	3.8	3A	4A	3A	4	3.8	4B	1A	10A	1B	9A	9B	7A	6	8A	8B	7	6A	6	9	5	
C	C36	C37	C1	C3	C6	C9	C8	C5	C4	C14	C11	C10	C12	C17	C19	C21	C24	C23	C25	C28	C29	C30	C32
R	R1	R2	R3	R4	R11	R12	R2	R3	R10	R16	R19	R20	R21	R22	R23	R24	R27	R28	R29	R30	R31	R32	R37
RELAY	RLC	RLC	RLC	RLC	RLC	RLC	RLC	RLC	RLC	RLC	RLC	RLC	RLC	RLC	RLC	RLC	RLC	RLC	RLC	RLC	RLC	RLC	RLC

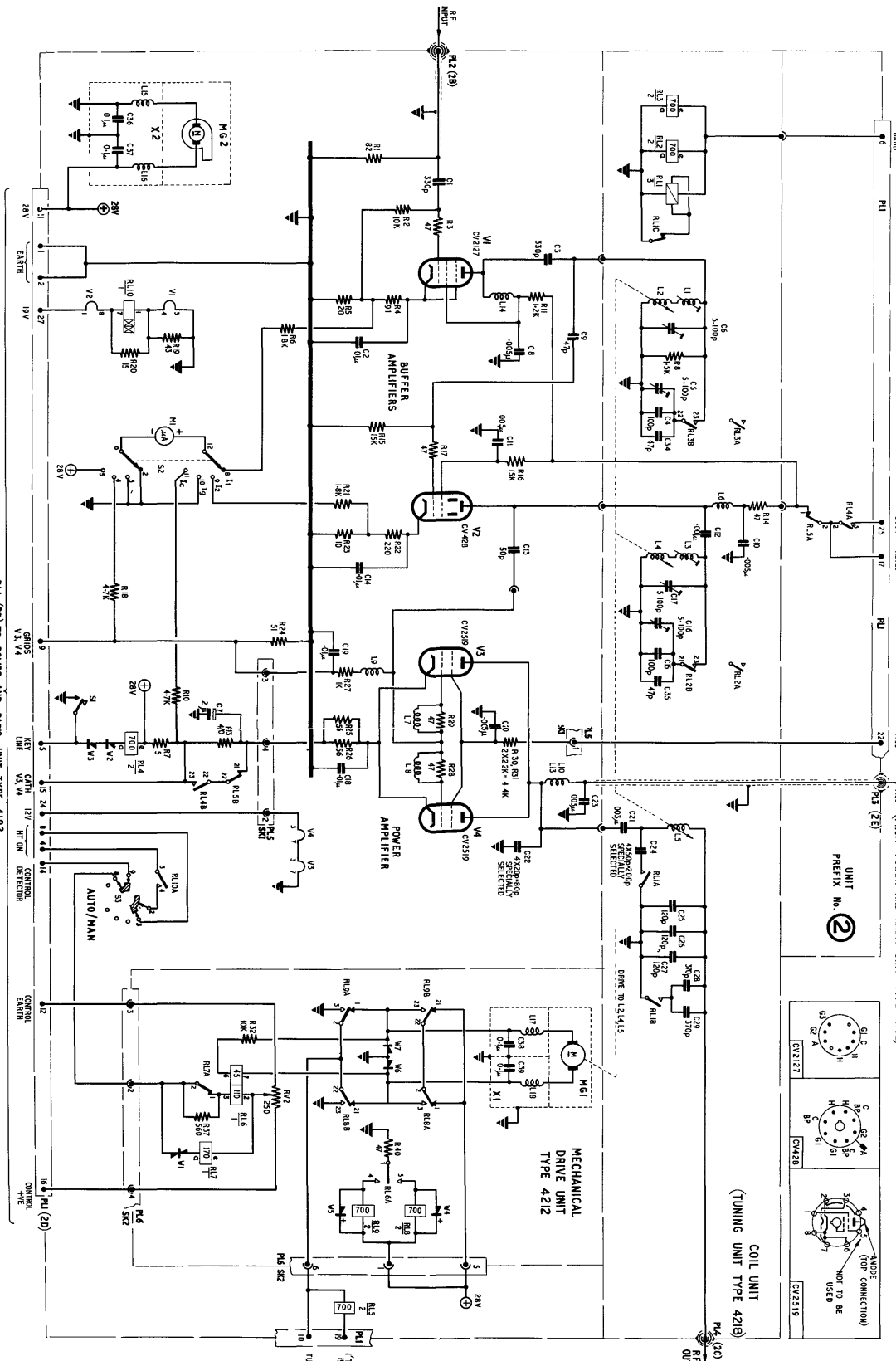

AIR DIAGRAM
603C/MIN.

ARI 5874 - Transmitter Type T 4188 - circuit
RESTRICTED

451288/6303 625 954 88UD Gp 979

AL G. Aug.

Chapter 5

POWER AND RADIO UNIT TYPE 4192

LIST OF CONTENTS

	Para.		Para.
<i>Introduction</i>	1	<i>Gain adjusting circuit (V.O.G.A.D.)</i>	29
<i>General description</i>		<i>Valve heaters</i>	32
<i>Construction</i>	5	<i>Modulating transformer</i>	33
<i>Interconnection of ARI.5874</i>	16	<i>Remote control circuits</i>	35
<i>Circuit description</i>		<i>Power supplies circuit</i>	36
<i>Audio frequency circuits</i>	18	<i>Rotary transformer</i>	39
<i>Relay function in audio circuits</i>	27	<i>Rotary transformer control circuits</i>	40
<i>Tone oscillator</i>	28	<i>Reduced power conditions</i>	49

LIST OF ILLUSTRATIONS

	Fig.		Fig.
<i>Front panel of power and radio unit Type 4192</i>	1	<i>Amplifying unit Type 4209—top</i>	5
<i>Top of main chassis</i>	2	<i>Amplifying unit Type 4209—underside</i>	6
<i>Underside of main chassis</i>	3	<i>Power and radio unit Type 4192—circuit</i>	7
<i>Block diagram of power and radio unit</i>	4		

INTRODUCTION

1. The power and radio unit Type 4192 provides HT power for the transmitter circuits; it has mounted on its chassis an audio amplifier (or modulator) sub-chassis known as the amplifying unit Type 4209.
2. In the power unit proper the main chassis carries a rotary transformer with outputs of 300V and 600V HT; both outputs are applied to the audio amplifier and transmitter circuits. Input power to the motor of the rotary transformer is from the aircraft 28V supply.
3. The input to the amplifying unit Type 4209 is from the intercommunications circuits of the equipment (microphone and key). A tone oscillator provides 1,000 c/s modulation on MCW and a parallel push-pull amplifier modulates the HT to the transmitter.
4. Amplifying unit Type 4209 will later be superseded by a unit with "speech-clipping" facilities; this unit will be known as amplifying unit Type 7435 (10U/16659) and all power and radio units Type 4192 will be retrospectively modified to incorporate the new amplifier.

GENERAL DESCRIPTION

Construction

5. The complete power and radio unit consists of a main chassis to which is attached the front panel measuring 8 by 10 inches and bearing the air intake dust filter (*fig. 1*). A removable dust cover fits over the whole chassis and is fixed at the rear of the unit by means of a quick release fastener. The depth of the unit is 12½ inches.
6. The whole base of the unit consists of a chassis 2½ inches deep and open on the underside. On the top surface of the chassis (*fig. 2*) is mounted the rotary transformer (left) and the amplifying unit Type 4209 (right). The modulating transformer (T3) is mounted to the rear of the amplifying unit.
7. A special bracket covers the HT brushes at the rear of the rotary transformer; this carries the valve heater dropping resistor R41 and can be swung clear for access to the brushes. The resistor is positioned in the cooling exhaust path to prevent overheating.
8. On the underside of the chassis (*fig. 3*) there is a group of control relays to the front left.

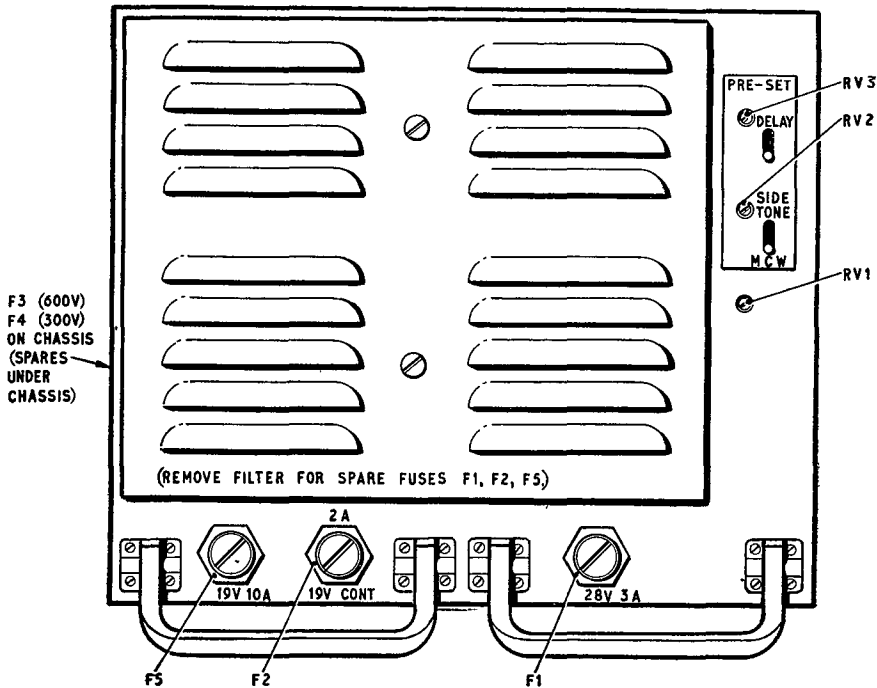

Fig. 1. Front panel of power and radio unit Type 4192

The centre of the chassis is occupied by a screened compartment which contains the rotary transformer connections, the noise suppression filters and the second relay of the motor start circuit.

9. The remainder of the chassis incorporates a motor start relay and components of the HT smoothing circuits.

10. Cooling air for the power and radio unit is drawn through the air filter box on the front panel (fig. 1) by a fan on the LT or front end of the rotary transformer.

11. Some of the air intake is passed through the rotary transformer and some is taken directly from the fan through a slot in the cowl and directed across the output valves of the amplifying unit Type 4209 by a duct-deflector. The air exhaust is through louvres in the rear top of the dust cover.

12. Two quick release fasteners enable the dust cover over the two air filters to be removed and the air filters freed. A further four fasteners allow removal of the baffle plate behind the filters. This permits the fan cowl of the rotary transformer to be withdrawn for inspection of

the LT brushes. The spare input fuses for F1, F2, and F5 are mounted on the baffle plate.

13. A sliding cover beside the air filter on the front panel provides access to three pre-set adjustments on the audio amplifier. These are:—

- (1) DELAY (in the V.O.G A.D. circuit)
- (2) SILETONE
- (3) MCW

14. The rotary transformer is held in position by means of two clamp bands on a saddle. When these and the air duct are released and the electrical quick release connections freed, the rotary transformer can be removed.

15. The amplifying unit Type 4209 is fastened to the main chassis by means of four captive screws. Input connections are made by plug and socket (PL3, SK6—fig. 2). The output connections are made to the top caps of the output valves V5 to V8; plug PL4 and socket SK7 connect the input to the double diode V9.

Interconnection of ARI.5874

16. The interconnection of the power and radio unit within the installation is made by plugs and sockets fixed to the rear face of the chassis. In

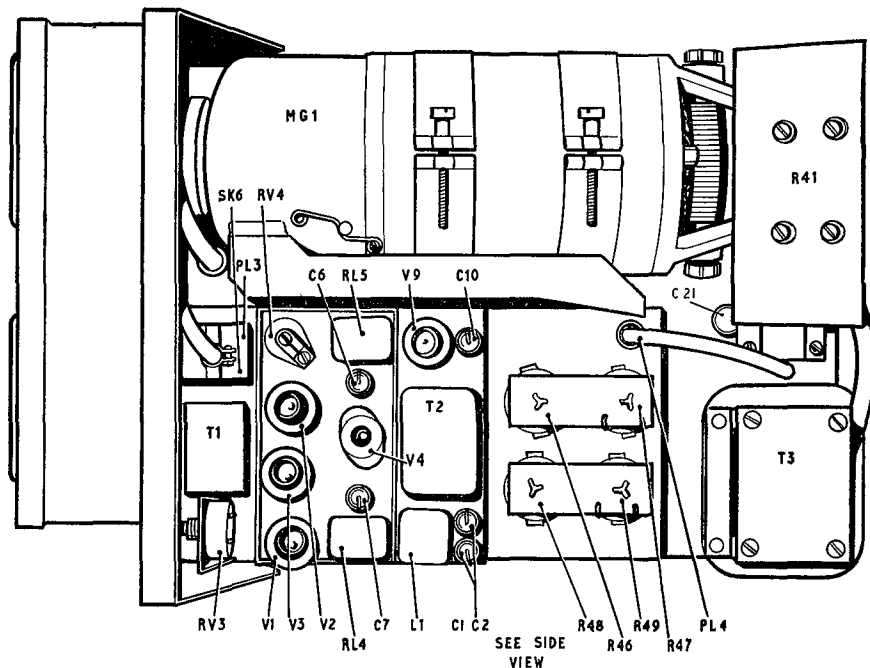

Fig. 2. Top of main chassis

RESTRICTED

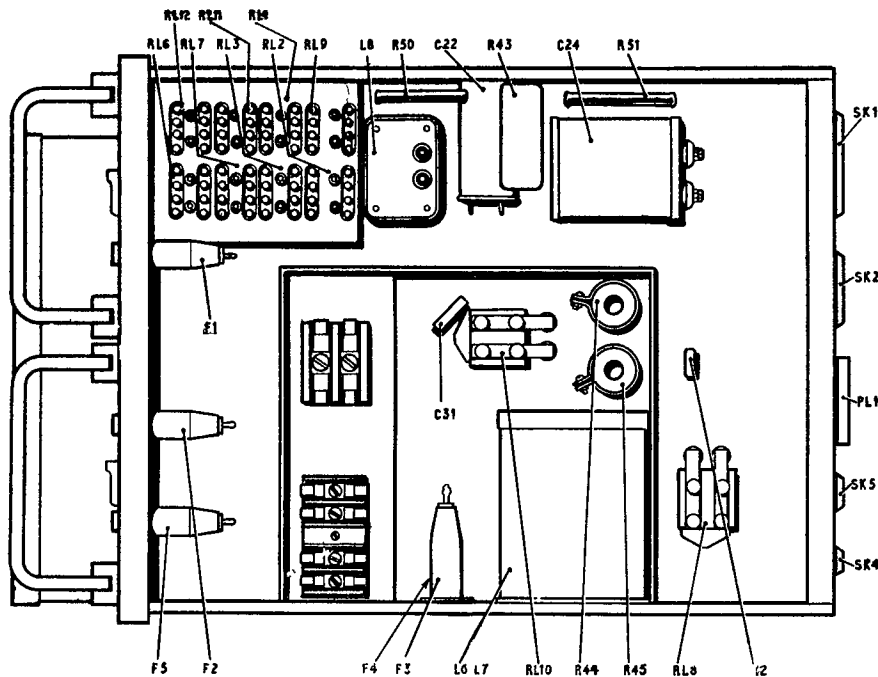

Fig. 3. Underside of main chassis

common with other units of the installation these plugs and sockets (seven in all) plug directly into a back-plate at the rear of the power and radio unit mounting assembly (*Chap. 10*).

17. The back-plate is interconnected to the remainder of the installation by means of connectors permanently wired to the back-plates of other units of the installation. Some details of the plugs and socket at the rear of the power and radio unit are given below; a more complete account is given in *Chap. 10*.

- (3P) PL1—20-pole plug Power supply input.
- (3E) PL2—Coaxial plug 600V HT modulated output to transmitter.
- (3D) SK1—28-pole socket Control and power supplies to transmitter.
- (3A) SK2—20-pole socket Control and power supplies to control and drive unit.
- (3J) SK3—4-pole socket Transmitter interlock.
- (3N) SK4—4-pole socket Receiver connections.
- (3F) SK5—8-pole socket Connections to intercommunications equipment (sidetone, key, mic. circuit and low power circuit).

Note . . .

PL2 and SK3 are mounted on a bracket above the chassis. The references in parenthesis are the backplate codings for the associated plugs or sockets.

CIRCUIT DESCRIPTION

Audio frequency circuits

18. The audio frequency circuits consists of (1) the amplifying unit Type 4209, which includes an

audio amplifier and modulating unit (*fig. 5*) and (2) the modulating transformer T3 (*fig. 2*).

19. A block diagram is given in *fig 4* and a complete circuit diagram of the power and radio unit is given in *fig. 7*, the audio frequency circuits are shown at the left of the diagram. It should be noted that the following references are not used in the circuit diagrams:—

R31 to R40, C11, C13 to C20, C23.

20. The balanced microphone input enters the power and radio unit at pins 3 and 4 of SK5 and is taken through screened leads via socket SK6 and plug PL3 (pins 1 and 2) to the primary winding of the transformer T1. The secondary winding is connected to the input stage V2 and V3 operating in push-pull.

21. The anode supplies of these valves is switched by the relay contacts RL4A (V3) and RL4B (V4) and HT is applied in the R/T condition only, HT is from the 300V KEY terminal 17 on the 28-pole socket SK1 via pin 11 on SK6 and PL3 and resistor R13 etc. The screen connections to the valves is from the 300V supply through the dropping resistor R10.

22. The bias supply is obtained partly from the cathode-bias of R3 and RV4 (GAIN) in series, the latter providing a preset adjustment of the audio gain of the amplifier on R/T, and partly from the grid bias, at the junction of R4 and R5. The grid bias is provided by the voice operated gain adjusting device (*para. 29*).

23. Coupling to the double-triode V4 is from the anodes via the relay contacts 4A and 4B, the anode load resistors R11 and R12 and the coupling condensers C6 and C7. The double-triode is connected in push-pull with its anodes supplied via the primary of the transformer T2; the centre-tap of the primary is connected to 300V HT via pin 12 of PL3 and SK6 and thence to pin 25 of SK1. This stage operates in Class A conditions and cathode-bias is provided by the 680-ohm resistor R16.

24. The output of V4 is coupled by winding 4—6 of the drive transformer T2 to the grids of the modulating stage of four valves V5—V8 operating in Class AB and connected in parallel push-pull. This stage is biased partly by the cathode resistor

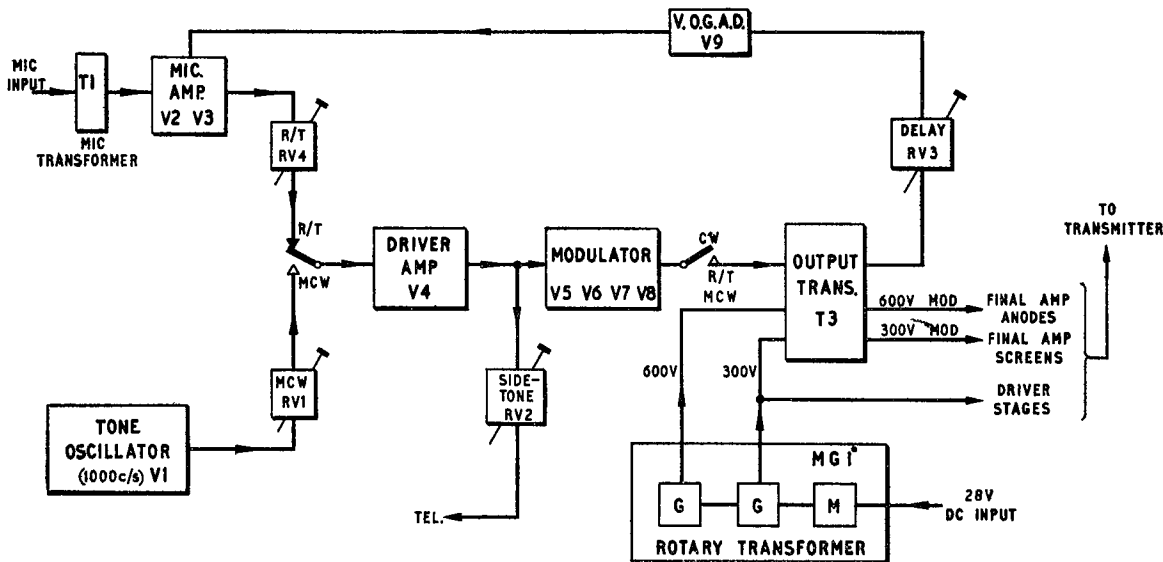

Fig. 4. Block diagram of power and radio unit

R23 (fig. 6) and mainly by the 28V supply from pin 3 of SK2; the connection is made via R23, pin 9 of PL3 and SK6, relay contact 2B, resistor R50 and relay contacts 1B and 3A. Contact 2B is paralleled by relay contact 5B connected through pin 8 of PL3 and SK6; the action of the relays is explained in para. 27.

25. When the 28V supply is removed, R24 acts as an extra cathode-bias resistor and biases the stage to cut-off. This occurs in the conditions described in para. 27 and is described in conjunction with the provision of sidetone.

26. A second winding (7—9) of the transformer T2 provides sidetone from the transmitter; adjustment of the sidetone level is by means of the preset resistor RV2 (SIDETONE) (para. 27).

Relay function in audio circuits

27. The following sub-paragraphs describe the function of the relays in the audio amplifier with relation to the selected position of the services switch on the remote control unit.

(1) **CW.** For CW facilities the modulator stage is not required; relay RL3/2 is un-energized and contact 3A remains open thus biasing off the modulator valves. The tone oscillator relay RL4/2 and the sidetone relay RL5/2 are operated, contacts 4A and 4B close and connect the output of the tone oscillator V1 to the grids of the double-triode V4. Sidetone is then available at the secondary of T2 and is selected at the lower level tap 8 by the closing of contact 5A. The closing of contact 5B is ineffective in the conditions obtaining. When the key is "made" relay RL2/2 is energized and contact 2A applies sidetone to the telephones via pin 1 of SK5. The closing of contact 2B is ineffective for the reason given for contact 5B. Closing the key circuit also applies 300V from pin 17 of SK1 to the tone oscillator V1; this circuit is completed by the operation of relay 2RL4 in the transmitter (Chap. 4).

(2) **MCW.** With MCW facilities the modulator stage is operated when the tone oscillator is keyed; sidetone is again at a reduced level via the relay contact 5A. Relay RL3/2 is energized via pin 4 on SK2 and relay RL5/2 is energized from pin 13 of SK2 (28V supply). Bias is applied to the modulator via resistor R50, contacts 3A, 1B, and contact 5B.

(3) **R/T.** For transmission on R/T the modulator stage operates only when the key is "made". Sidetone is selected at the higher level since contact 5A does not operate. Relay RL3/2 is energized from pin 4 of SK2 and bias is applied to the modulator via contact 3A. Contact 5B remains open and the modulator stage operates only when relay RL2/2 is energized thus closing contact 2B.

(4) **INT.** When the equipment is being set up in the INTERTUNE condition, relay RL1/2 is energized from, either contact pin 10 of SK1 or pin 10 of SK2. Contact 1B opens and effectively puts the modulator in the CW condition.

Tone oscillator

28. The double-triode V1 is connected as a push-pull audio oscillator operating at approximately 1,000 c/s. The fixed-tuned circuit consists of the coil L1 and the condensers C1 and C2. The valve is biased by the preset RV1 which provides adjustment of output level and consequently the modulator gain on MCW. The condensers C3 and C4 provide the necessary feedback from the anode loads R9 and R8, respectively. The oscillator is keyed in the HT supply via pin 17 of SK1.

Gain adjusting circuit (V.O.G.A.D.)

29. This circuit is generally known as a "voice operated gain adjusting device" or "V.O.G.A.D." A connection is taken from the "live" side of the 300V modulated winding of transformer T3 through C21, SK7 and PL4 to the cathode of V9

RESTRICTED

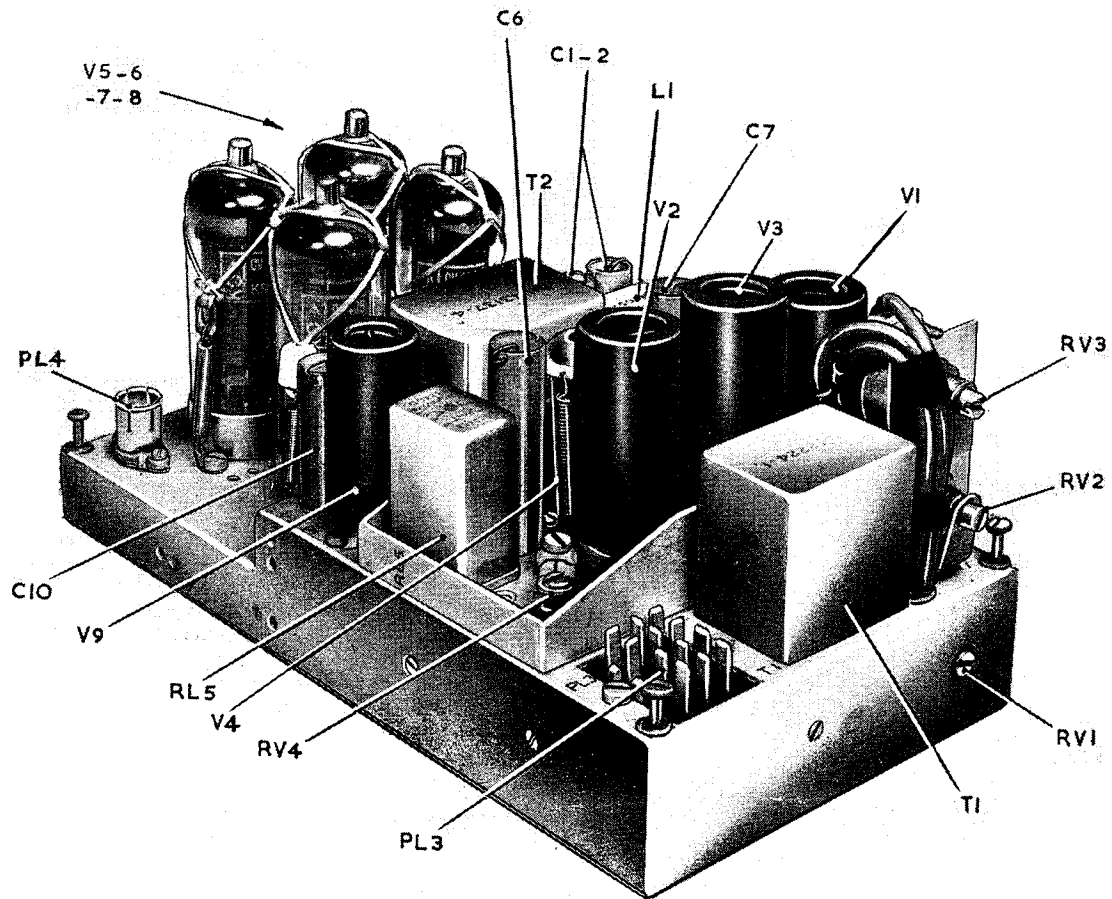

Fig. 5. Amplifying unit Type 4209—top

on the amplifier chassis. This valve is a double-diode CV140 connected in parallel.

30. During operation, some of the audio output of the amplifier is rectified and thus develops a negative DC potential across R26 in the diode anode. This is filtered by R25 and C10 and taken via a screened cable to the centre point of the resistors R4 and R5 in the input stage. The cathode of the V.O.G.A.D. valve V9 is positively biased by means of R28 and R27 from the 300V supply.

31. When the input rises above a certain level i.e., when the input to the diode exceeds the positive bias applied to its cathode by R28 and R27, the valves V2 and V3 are biased back in proportion to the increase in output to reduce the overall gain of the amplifier, thus preventing over-modulation. The amplifier gain and the V.O.G.A.D. delay is adjusted to operate on approximately half the normal microphone input so that some measure of compensation for under modulation is also applied. The potentiometer RV3 (DELAY) is used for adjustment of the audio voltage level applied to the diode and thus allows a point of operation to be preselected.

Valve heaters

32. The valve heaters are connected in series parallel with the 19V stabilized supply from pin 14 of SK2 through the 2-amp fuse F2 (fig. 7).

Modulating transformer

33. The anodes of the modulator valves V5, V6, V7 and V8 are connected to the primary of the modulating transformer T3, the anode supply being obtained from the 600V applied to the centre tap. This transformer is not a part of the chassis of the amplifying unit Type 4209 but is mounted adjacent to the rear end of this on the main chassis (fig. 1).

34. Of the secondary windings of the transformer, the output 5-6 is connected to supply 600V modulated to the transmitter P.A. anodes via coaxial plug PL2. Secondary 7-8 is connected to supply 300V modulated to the screen grids of the P.A. valves via pin 22 on socket SK1.

Remote control circuits

35. These are covered in Chap. 2 and will not be described here.

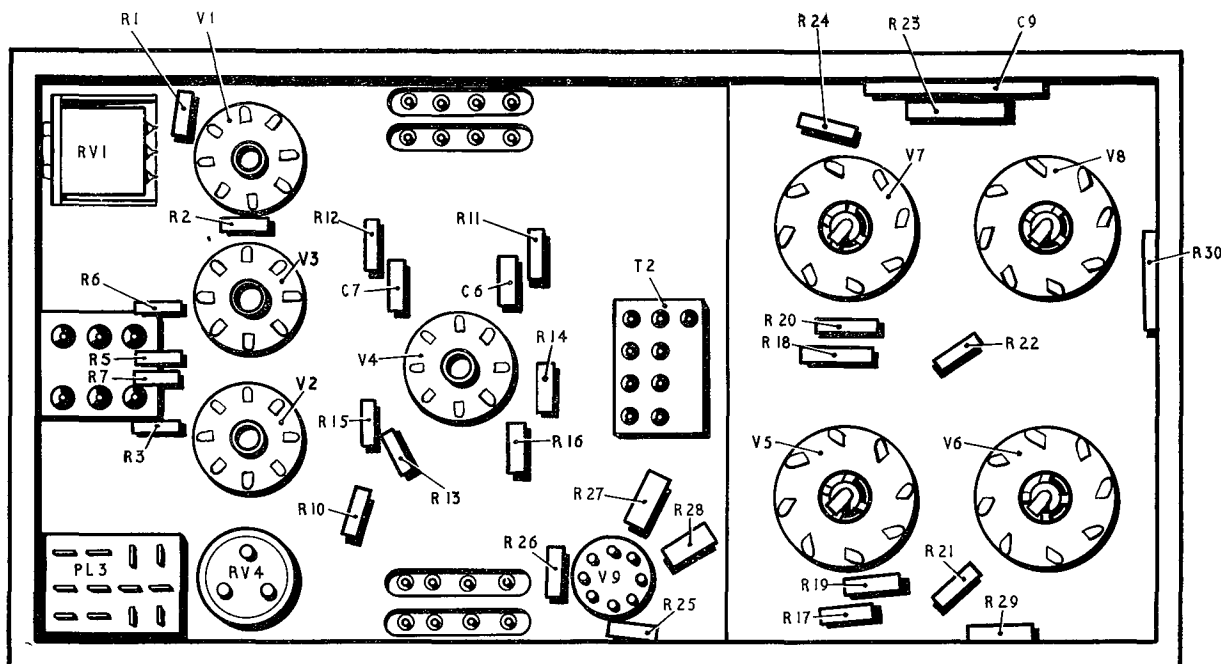

Fig. 6. Amplifying unit Type 4209—underside

Power supplies circuit

36. The input power supplies to the whole of the transmitter equipment is applied via PL1; with 28V positive on pins 13-20, 19V positive (regulated) on pins 11 and 12 and the common earth on pins 1-10.

37. When the equipment is switched to STANDBY the relay RL6/1 is energized and closes the contact 6A thus connecting the 28V supply through the 3-amp fuse F1 to the control circuit. Contact 6A also completes the circuit of the energizing coil of RL7/1 which closes contact 7A and connects the 19V positive lines to the control circuits and to all the valve heaters of the equipment.

38. The following fuses are mounted on the front panel of the equipment :—

(1) Fuse F1, 3-amp. Protects the 28V control circuits.

(2) Fuse F2, 2-amp. Protects the 19V control circuits and the valve heaters in control unit Type 4190 or Type 4243.

(3) Fuse F5, 10-amp. Protects all the 19V supplies.

Rotary transformer

39. The rotary transformer is intended to operate at a nominal input of 28V as normally provided by the aircraft battery supplies. There are two secondary windings giving 300V and 600V HT respectively. These outputs supply 300V and 600V HT to the incorporated amplifying unit Type 4209; and 300V HT to the crystal-controlled oscillator in the control unit Type 4190; the 300V supply (modulated and unmodulated), and the 600V supply (modulated) is applied to the transmitter unit.

Rotary transformer control circuits

40. In the HT ON or TX condition of the equipment relays RL8/1 and RL9/2 are energized from pin 2 of SK3. Contact 8A makes and connects the 28V supply from PL1 to the motor side of MG1 through the low value resistors R44 and R45. At rest, the armature approximates to a short-circuit and most of the volts are dropped across R44 and R45 so that RL10/1 cannot operate.

41. As the speed of the motor and the armature resistance increases, the back EMF builds up to approximately 20-24 volts and relay RL10/1 is energized through the closed contact 9A. Relay contact 10A closes and short-circuits the starting resistors R44 and R45, thus allowing the motor to reach its maximum speed.

42. The relay contact 9B breaks the circuit between pins 3 and 4 of SK3 and can be used to interlock with the circuit of any other equipment in the aircraft which may be connected to SK3. When SK3 is not connected to other equipment pin 1 and 2 are shorted by a special link which is plugged into the back-plate.

43. After transmission, the relays RL8/1 and RL9/2 are de-energized and the motor-generator switched off. Contact 9A breaks the circuit of RL10/1 and contact 10A reinserts the starting resistors in the motor circuit ready for any immediate restart.

44. The negative side of the motor winding is earthed via PL1. Noise suppression on the positive side is provided by the two-stage filter L6, C25 and L7, C26 mounted in a screened box. (fig. 3).

45. Outputs from the generator side of the machine are provided by two armature windings

RESTRICTED

giving, respectively, 300V HT and 600V HT. The 300V output is connected through the noise filter L5, C28 and L4, C27 and then through L8, C22 connected as a one-stage ripple filter.

46. The 600V output from the machine is taken through the noise filters L3, C30 and L2, C29 to the secondary winding of transformer T3 and C24 which gives some ripple suppression.

47. Fuses F3, 750mA and F4, 250mA protect the HT circuits and the "noise" filters. They are mounted inside the unit to avoid bringing unfiltered leads and dangerous voltages to the front panel of the equipment. Spare fuses for F3 and F4 are mounted under the chassis.

48. The resistor R43 in the 300V line to the secondary winding of transformer is brought into circuit by the breaking of relay contact 11A. Relay RL11/2 is energized when the equipment is in the SAFE condition (from pin 19 of SK2) and R43 limits the screen potential of the transmitter P.A. stage.

Reduced power conditions

SAFE

49. The SAFE condition is provided primarily to reduce the output power of the transmitter a safe level for the prevention of corona discharge which may occur at altitude in the

event of a pressure leak in the suppressed aerial tuning unit (*Sect. 2, Chap. 3*).

50. This low power facility is also provided under control of the operator in the form of a HIGH/LOW power switch connected between pin 6 of SK5 and earth on the "Intercom" output socket.

51. SAFE conditions occur when the LOW POWER line is earthed by the LOW POWER switch or the barometric switch in the suppressed aerial tuning unit (*para. 49*). An immediate reduction in power is obtained since the screen potential of the P.A. stage is reduced by the potential divider formed by R43 and R51, the latter being taken to earth via pin 20 of SK2 and the control unit Type 4190 at 1RL7B (*Chap. 3*).

52. In addition to the reduced power obtained at the P.A. stage, relay contact 11B opens and inserts an extra cathode bias resistor R50 in the audio output stage V5—V8.

TUNE

53. When the TEST TUNE KEY on the control and drive unit or the suppressed aerial selector unit is in the TUNE position, the resistor R51 is removed from its earth connection by 1RL7B in the control and drive unit (via pin 20 of SK2—*fig. 6*). Tuning can then take place at nearly full power since only R43 remains to limit the screen voltage.

1	2	3	4	5	6	7	8	9	10	11	12	13	14	15	16	17	18	19	20	21	22	23	24	25	26	27	28	29	30	31	32	33	34	35	36	37	38	39	40	41	42	43	44	45	46	47	48	49	50	51	52	53	54	55	56	57	58	59	60	61	62	63	64	65	66	67	68	69	70	71	72	73	74	75	76	77	78	79	80	81	82	83	84	85	86	87	88	89	90	91	92	93	94	95	96	97	98	99	100
---	---	---	---	---	---	---	---	---	----	----	----	----	----	----	----	----	----	----	----	----	----	----	----	----	----	----	----	----	----	----	----	----	----	----	----	----	----	----	----	----	----	----	----	----	----	----	----	----	----	----	----	----	----	----	----	----	----	----	----	----	----	----	----	----	----	----	----	----	----	----	----	----	----	----	----	----	----	----	----	----	----	----	----	----	----	----	----	----	----	----	----	----	----	----	----	----	----	----	-----

A.P. 2535E, Vol. 1, Part 1, Sect. 1, Chap. 5 (A1.5)

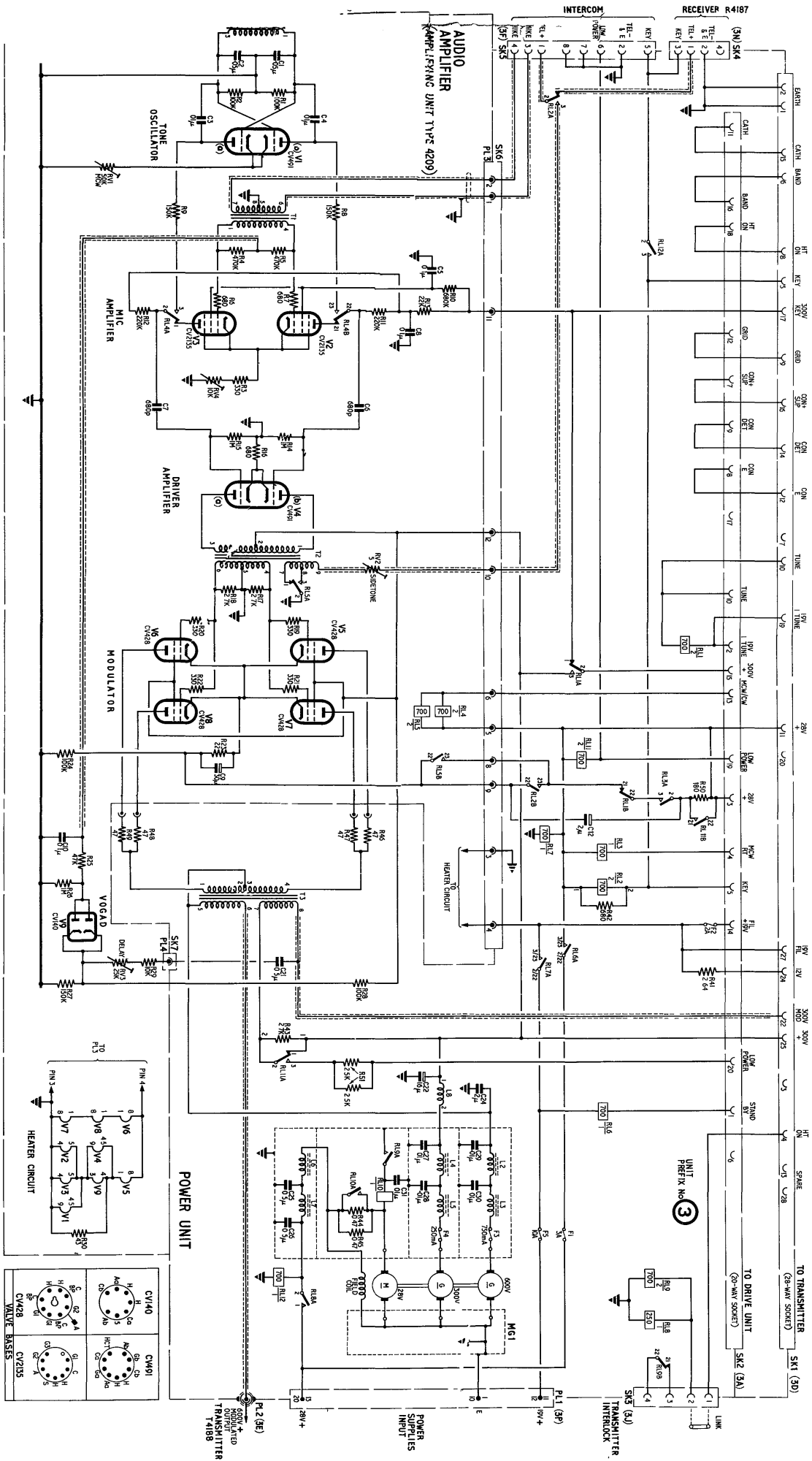

Chapter 6

CONTROL UNIT (REMOTE) TYPE 4189 AND JUNCTION BOX TYPE 4191

LIST OF CONTENTS

	Para.		Para.
<i>Introduction</i>	1	<i>Fine tuning control (RV1)</i>	15
<i>Low power and AGC switches</i>	3	<i>RF gain control (RV3)...</i>	17
<i>Mounting of control unit...</i>	5	<i>Dimmer (RV2) and dial lamp (LPI)</i>	18
<i>Circuit description of control unit</i>	7	<i>TUNE indicating lamp (LP2)...</i>	19
<i>Channel letter switch (S1)</i>	8	<i>Milliammeter (MI)</i>	20
<i>Channel number switch (S2)...</i>	9	<i>Earth</i>	21
<i>Power switch (S3)</i>	11	<i>Junction box Type 4191</i>	22
<i>Service switch (S4)</i>	14		

LIST OF ILLUSTRATIONS

	Fig.		Fig.
<i>Control unit (remote) Type 4189—front</i>	1	<i>Control unit (remote) Type 4189—circuit</i>	4
<i>Rear of control unit</i>	2	<i>Junction box Type 4191—circuit</i>	5
<i>Junction box Type 4191</i>	3		

INTRODUCTION

1. Control unit (remote) Type 4189 is designed for either panel or console mounting according to the requirements of the particular installation. All the controls required for operation of the ARI.5874 are brought out to the remote control unit (with two exceptions—*para.* 3) and will be used by the operator for both normal operation and setting up purposes. All the connections from the control unit

to the transmitter and receiver circuits are made via the junction box Type 4191.

2. No “local” control facilities are available and all power and service switching is made at the control unit. The controls and switches on the front panel are given against the circuit references as shown in fig. 1 and 4.

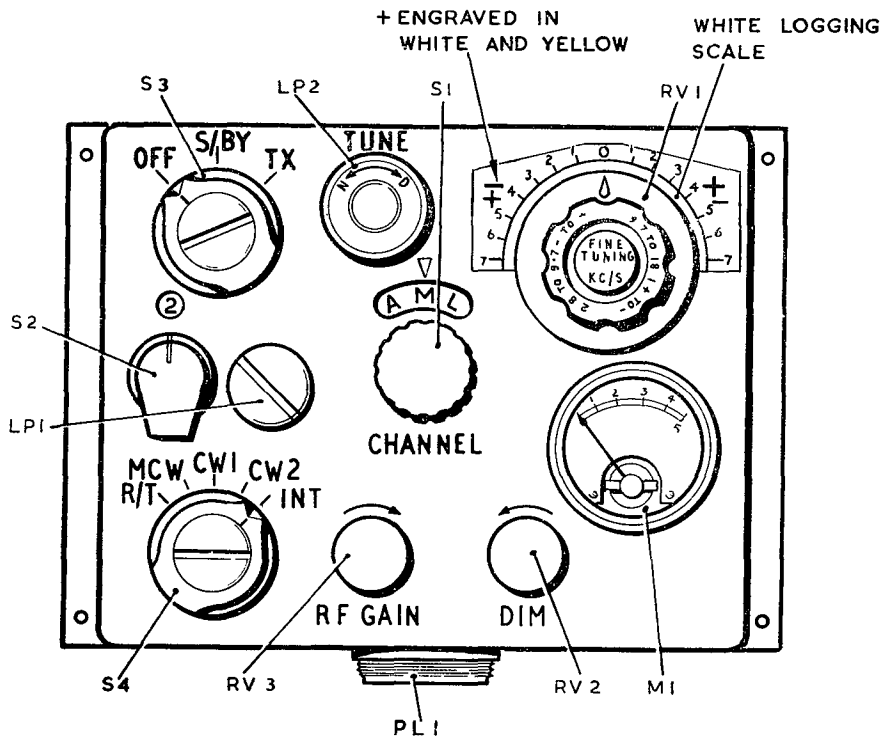

Fig. 1. Control unit (remote) Type 4189 front

Item	Circuit Ref.	Description
Channel letter switch	S1	Starts the channel selector motor and open circuits the motor relay when the channel has been selected.
Channel number switch	S2	Selects one of the two 12 channel groups 1A to 1M or 2A to 2M
Power switch	S3	3-position switch (OFF-S/BY-TX). s/BY (Standby). Switches on receiver and heaters of transmitter, and P.A. valves blower motor. TX. Switches on transmitter HT.
Service switch	S4	Selects one of the following services on both transmitter and receiver. R/T. In this position the switch earths the R/T-MCW line. MCW. Places transmitter on MCW by earthing MCW/CW relay. CW1. Puts transmitter in CW condition by releasing RT/MCW line. Puts receiver in CW condition by earthing receiver CW line. CW2. Condition as for CW1 but additional relay in receiver operates which changes the IF bandwidth. INT. The INTertune facility is given by switching on the transmitter oscillator and breaking the receiver mute line, thus enabling the receiver to be tuned back to the transmitter.
FINE TUNING	RV1	This controls a Desynn motor affecting the frequency of the receiver by a variation of plus or minus 7 kc/s. It may also be used as a beat note control.
RF GAIN	RV3	Gain control of receiver.
DIM	RV2	Dimmer for channel number and letter switches window illumination.
TUNE	LP2	Tuning indicator dimmed by an iris. Glows when any tuning operation is in progress or when the receiver is left in the INTERTUNE position. The lamp will not glow when the transmitter is switched to MANUAL.
Meter	M1	The meter is calibrated 0-5 and indicates aerial excitation when the transmitter is on "mark". The meter will not indicate if either the transmitter or wire aerial coupling unit is left on MANUAL.

RESTRICTED

Note . . .

FINE TUNING control. The dial against this control reads error plus-or-minus in the range 2.8 to 9.7 Mc/s and minus-or-plus for 9.7 to 18.1 Mc/s., i.e. the calibration changes sign at 9.7 Mc/s. As indicated in fig. 1, the plus and minus signs are marked in pairs coloured yellow and white, respectively to correspond to the frequency ranges engraved on the control knob. A white band adjacent to the edge of the knob is intended as a logging scale for pencil marking.

Low power and AGC switches

3. In addition to the controls and switches on the remote control unit, switches are provided for the operation of the transmitter on low power and for the operation of the receiver with or without automatic gain control.

4. The low power switch is provided as part of the aircraft radio installation and is normally mounted close to the remote control unit. The AGC ON/OFF switch is mounted on the front panel of the receiver.

MOUNTING OF CONTROL UNIT

5. To facilitate either panel or console mounting of the control unit, two angle brackets are provided which may be fitted either to the rear of the control unit cover for panel mounting or at the front of the cover for console mounting.

6. The 25-way plug Mk. 4 (PL1) is mounted on a detachable plate which may be fitted to the underside of the control unit for panel mounting, or to the rear of the control unit for console mounting. The wiring loom to the plug is so arranged that it allows for the movement of the plug mounting plate from one position to the other without disturbance of the connections.

CIRCUIT DESCRIPTION OF CONTROL UNIT

7. The circuit of the remote control unit is not complete in itself for obvious reasons ; the following description, therefore, is devoted to the interconnection of the switches and controls with the circuits of the other units within the installation. The circuit of the control unit is shown in fig. 4.

Channel letter switch (S1)

8. There are seven connections from the channel letter switch, six of these are to pins A-F of plug PL1 and the seventh is earthed to the control unit chassis. The outgoing connections from PL1 are via the junction box to the receiver. The circuit details are in Chap. 7.

Channel number switch (S2)

9. The channel number switch has two wiring connections, one to earth on the control unit chassis and one to pin 0 of PL1. The outgoing connection from PL1 is via the junction box to the receiver and control and drive unit.

10. When the channel number switch is in position 2 an earth line is connected to relays 4(3)RL1 and 4(3)RL2 in the receiver, and relays 1RL3, 1RL4 and 1RL5 in the control and drive unit. In each case the relays change over the connections of the control circuits from one range of 12 crystals etc. (1A-1M), to the second range of 12 crystals etc., (2A-2M).

Power switch (S3)

11. The power switch has three positions OFF-s/BY-TX. In the s/BY and TX positions pin V of PL1 is earthed via the switch ; the outgoing connections from pin V are to relays in the receiver and control and drive unit. These relays switch on the receiver and the heaters of the transmitter.

12. The switch is also connected to pin W of PL1 so that in the TX position the 19V supply from the receiver is connected to the MG start relay 3RL8 and the interlock relay 3RL9 in the power and radio unit.

13. In the s/BY and TX positions of the switch, the 19V supply from the receiver is also connected to the TUNE lamp LP2 which by virtue of its connection to pin J of PL1 will be operated by an earth on the "mute" line in the receiver or an earth on the switch sector S4C in the INTertune position.

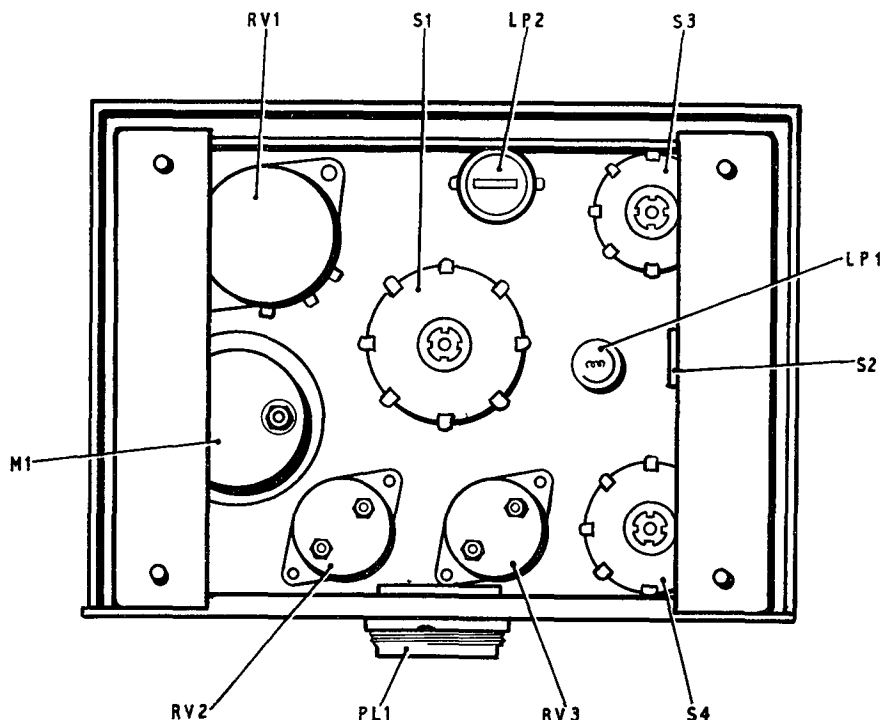

Fig. 2. Rear of control unit

Service switch (S4)

14. This is a 5-position switch giving the following facilities :—

RT—MCW—CW1—CW2—INTertune. The connections to PL1 are as follows :—

Switch position	Switch sector	Plug pin	Function
R/T	S4A	—	—
R/T	S4B	—	—
R/T	S4C	H	(see MCW)
MCW	S4A	—	—
MCW	S4B	M	Earths MCW/RT line
MCW	S4C	H	Connects MUTE line to MUTE line J.
CW1	S4A	Z	Earths CW1 line.
CW1	S4B	L	Earths MCW/CW line.
CW1	S4C	H	(See MCW)
CW2	S4A	Y	Earths CW2 line.
CW2	S4B	L	(See MCW)
CW2	S4C	H	(See MCW)
INT	S4A	—	—
INT	S4B	J	Operates TUNE lamp LP2 and earths MUTE line to relays in the power and radio unit and the transmitter.
INT	S4C	—	—

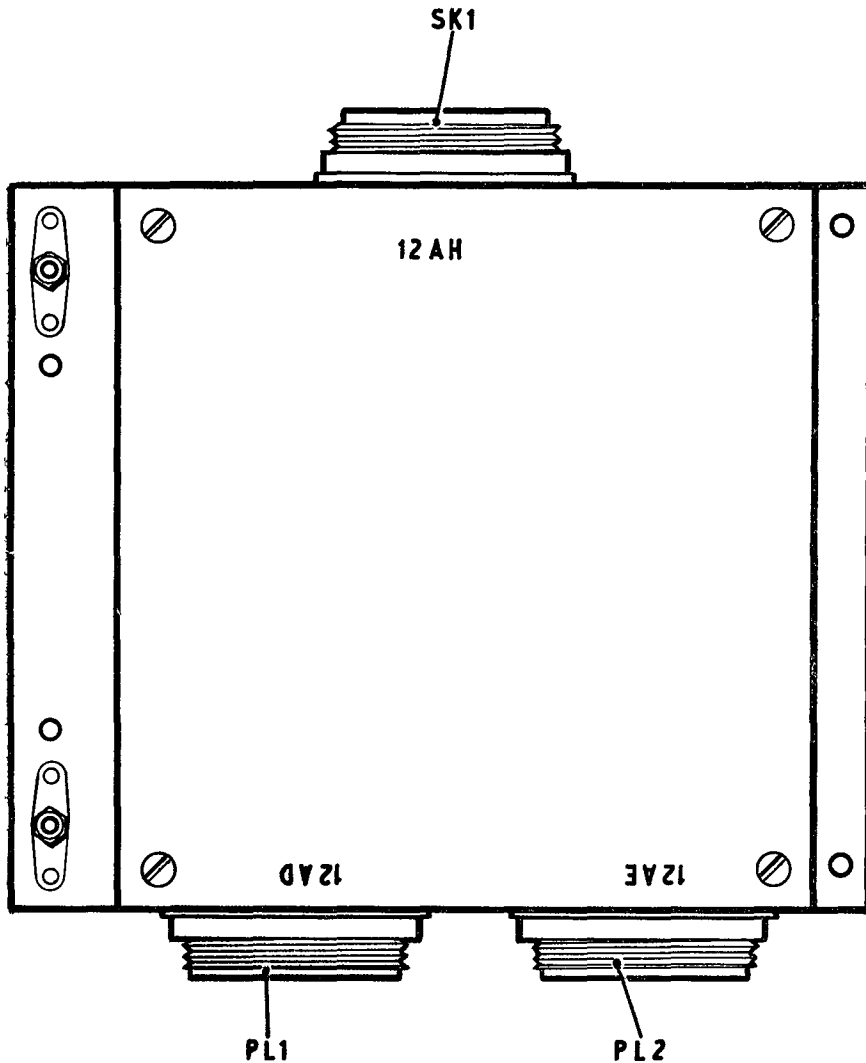

Fig. 3. Junction box Type 4191

Fine tuning control (RV1)

15. Desynn control having three out-going connections to PL1, pins P, Q and R; these are connected to the Desynn motor in the receiver IF unit via the junction box.

16. A fourth connection from pins of PL1 supplies 19V via the dropping resistor R1 to the fine tuning control (RV1). The control is earthed to the chassis of the control unit.

RF gain control (RV3)

17. The RF GAIN control is connected between earth and pin U of PL1 ; the out-going connection is to the receiver RF unit.

Dimmer (RV2) and dial lamp (LP1)

18. The dimmer control is connected between the dial lamp LP1 and the 19V supply at pin S of PL1. The other side of the dial lamp is earthed to the control unit chassis.

TUNE indicating lamp (LP2)

19. The TUNE lamp is connected between the switch sector S3A and pin J of PL1 (para. 11).

RESTRICTED

Milliammeter (M1)

20. The meter gives an indication of aerial excitation (calibrated 0-5) and is connected between pins T and N of PL1. The out-going connections are to the aerial tuning unit of the particular aerial system in use.

Earth

21. The earth connection of the control unit chassis is taken via pin G of PL1 to the general earth line of the equipment.

Note . . .

Pins K and X of PL1 are not connected.

JUNCTION BOX TYPE 4191 (fig. 3)

22. Junction box Type 4191 is interposed between the control unit (remote) Type 4189 and the transmitting and receiving circuits of the ARI.5874.

23. It is bulkhead mounted with one multipole socket connecting with a cable to the remote control unit and two multipole plugs connecting one to the receiver Type R.4187 and one to the transmitter control circuits in the control unit Type 4190.

24. There are no components in the junction box other than wiring and the circuit diagram given in fig. 5 is self-explanatory. The details of the plugs and socket are given below :—

SK1—Marked 12AH (25-way socket, fixed, multipole, position 0) Ref. No. 10HA/14162Z. This is connected via cable AH to the remote control unit.

PL1—Marked 12AD (25-way plug, fixed, multipole, position 3) Ref. No. 10HA/14152Z. This is connected via cable AD to plug PL7 on the receiver.

PL2—Marked 12AE (25-way plug, fixed, multipole, position 0) Ref. No. 10HA/14153Z. This is connected via cable AE to plug PL2 on control unit Type 4190.

25. Details of the connectors between the junction box, remote control unit, receiver, and control and drive unit are given in Chap. 10.

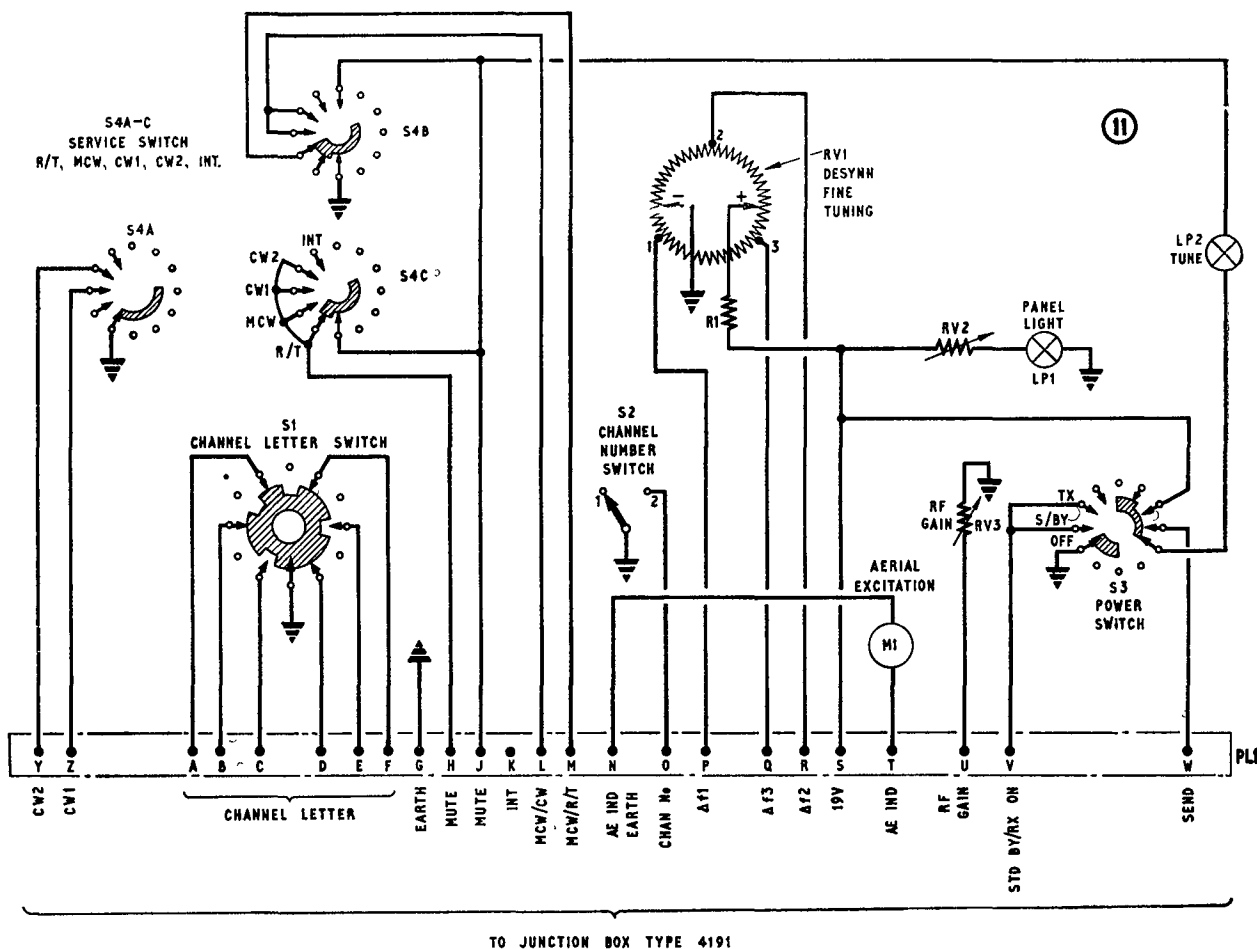

TO JUNCTION BOX TYPE 4191
Fig. 4. Control unit (remote) Type 4189—circuit

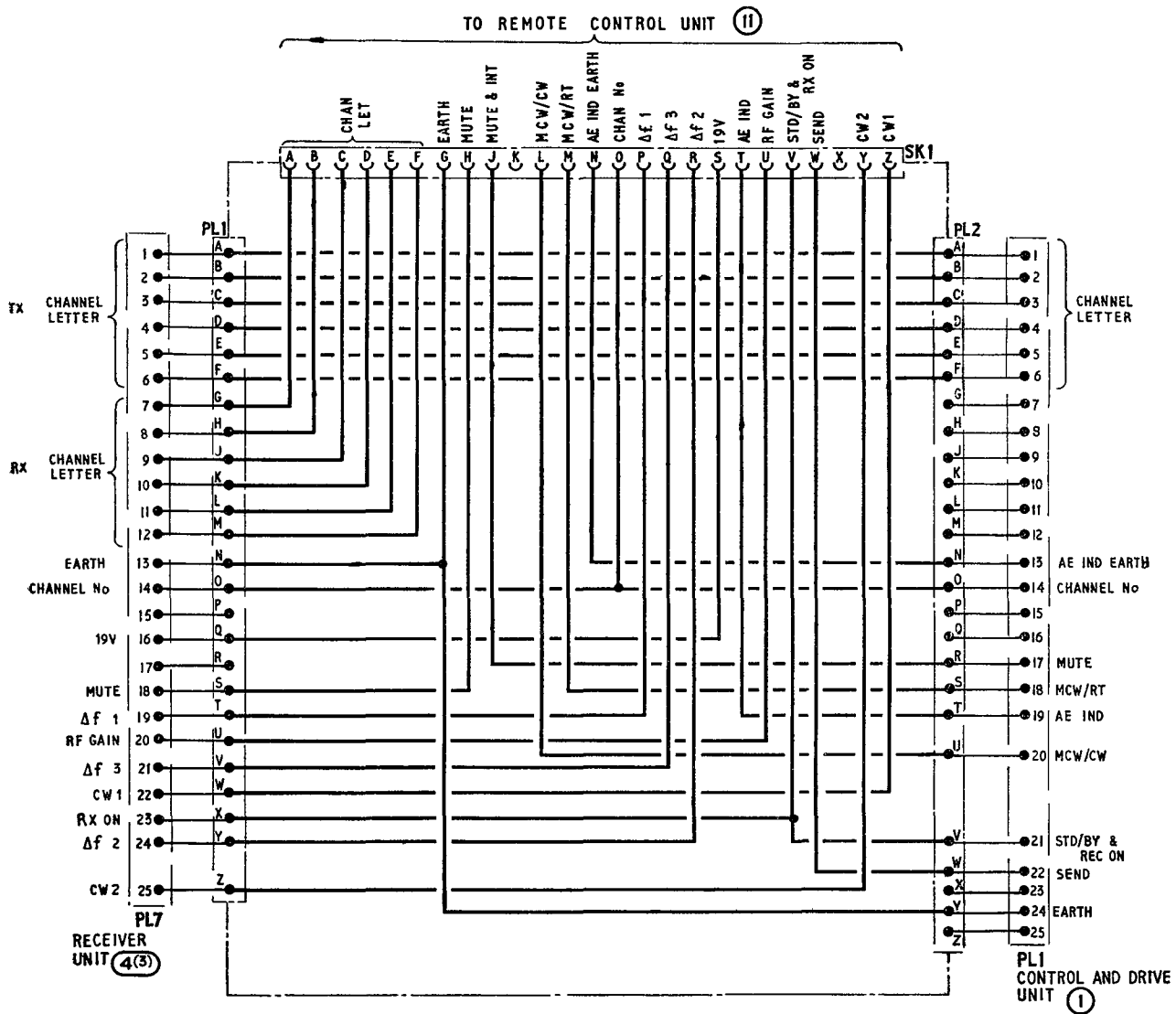

Fig. 5. Junction box Type 4191 — circuit

RESTRICTED

Chapter 7.

REMOTE CONTROL AND SWITCHING SYSTEM

LIST OF CONTENTS

	Para.		Para.
INTRODUCTION	1	Wire aerial operation	67
REMOTE CONTROL SYSTEM	5	19V supply circuit for suppressed aerial operation	69
The selector circuit	7	19V supply circuit for wire aerial operation ...	74
12-way potentiometers	19	28V supply circuit for suppressed aerial operation	77
Selection of channel number	25	28V supply circuit for wire aerial operation ...	80
Tuning motor circuits	27	300V HT circuit for transmitter only... ..	82
CONTROL AND SWITCHING CIRCUITS	49	600V HT circuit for transmitter only... ..	83
"Standby" circuit	50	INTERTUNE/TUNE circuit	85
Transmitter "HT ON" circuit	55	"TUNE" line	86
"Key" circuit	61	Circuit of "TUNE" line with transmitter and receiver ON	87
Suppressed aerial operation	66	Suppressed aerial operation	88
		Wire aerial operation... ..	89

LIST OF ILLUSTRATIONS

	Fig.		Fig.
Mechanical drive unit of receiver	1	Simplified key circuit	7
Theoretical version of selector motor control circuit ...	2	Simplified 19V circuit	8
Channel selection circuits—simplified	3	Simplified 28V circuit	9
Simplified circuit of channel number switch and relays ...	4	Simplified 300V circuit	10
Simplified circuit of remote control tuning system	5	Simplified 600V circuit	11
Simplified "Standby" and transmitter "HT ON" circuit	6	Simplified INTERTUNE/TUNE circuit	12

INTRODUCTION

1. To provide automatic tuning on 24 pre-selected frequency channels, the units to be tuned are fitted with mechanical drive units geared to the tuning circuit. These units are the transmitter, receiver and aerial tuning unit; the aerial tuning unit may be part of a suppressed aerial system or, alternatively, part of an open wire aerial system. The mechanical drive unit of the receiver is illustrated in fig. 1.

2. Each mechanical drive unit is driven by an electric motor actuated indirectly by the "unbalance current" of a self-balancing resistance bridge (Wheatstone Servo); one "side" of the bridge is formed by a potentiometer in the tuning circuit, the other "side" being a potentiometer driven by the channel selector motor.

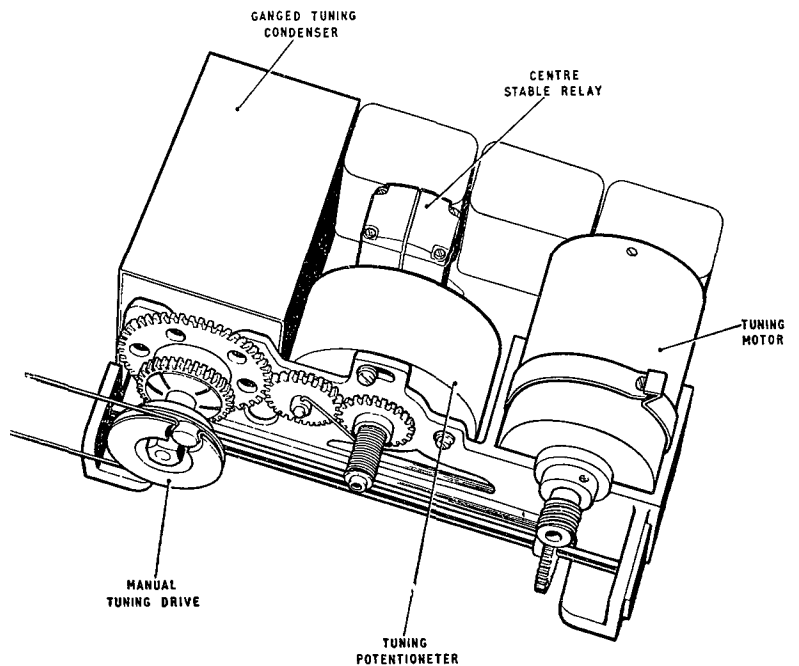

Fig. 1. Mechanical drive unit of receiver

9. At any point when a channel has been chosen by moving the manual channel selector switch at the remote control unit, and when that channel has been subsequently selected by the selector motor of the receiver (or transmitter—*para.* 17) there will be an open-circuit between the channel letter switch and the finder switch of the receiver (or transmitter).

10. When the equipment is in the "Standby" condition the selector motor is connected to the 19V supply as soon as the motor relay operates. The motor relay can be energized only through the channel letter switch or the centering switch driven by a cam on the motor shaft (*para.* 9). In the conditions shown in fig. 2a, i.e. with a channel selected, the motor relay will be open-circuited and the selector motor will be at rest.

11. Now assume that the channel letter switch is moved to a "new" position. This will place an earth on the motor relay through the finder switch and the relay will be energized from the 28V supply. The motor relay contact will remove the earth from the armature and connect the motor to the battery supply. The motor will then rotate until the finder switch moves to the identical channel position of the channel letter switch. (As shown in fig. 2a).

12. At this point an open-circuit occurs between the two switches, the relay is de-energized and its contact switches the motor off. The opening of the relay contact short-circuits the input terminals of the motor thus braking the motor and preventing over-run.

13. To ensure that the motor stopping points are accurately maintained at 30 deg. apart, the centering switch opens at the centre of each of the 30 deg. positions of the finder switch and removes the ambiguity of the relatively wide "no-contact" arcs. This is achieved by maintaining the relay energizing circuit with the centering switch contact for a longer period than would be the case with the finder switch contacts.

14. The centering switch has two "clicker" springs riding on the motor driven cams which operate to break the relay circuits at 30 deg. intervals, these intervals being positioned inside the arc of the finder switch wiper.

15. In the practical case it was found necessary to economize in the number of leads used between the remote control unit and the transmitting/receiver units. To this end the switch segments of the channel-letter and finder switches were modified in shape and the connections reduced to six. The letter switch has a specially shaped wiper which earths up to four of the six connections. The wiper of the finder switch is electrically the reverse of the letter switch wiper in that it provides a "break" in the corresponding "make" angular positions.

16. Twelve channels are available as before and the principle is similar to that described in para. 8 to 14. A study of the simplified circuit in fig. 3 will show that for each related "channel" position

of the two switches an open circuit occurs between the switches. For the condition where the finder switch segment is in a different angular position to the channel letter switch in the remote control unit, an earth is connected to the relay circuit and the selector motor will run until the finder switch is rotated to the same angular position as the selected position of the channel letter switch.

17. The channel letter switch connections from the remote control unit are shown connected to the finder switch in the receiver (fig. 3), and it can be seen that there are no connections from the remote control unit to the transmitter. In fact, a similar switch segment to that of the remote control unit is mounted on the same shaft as the finder switch in the receiver unit. This switch segment is rotated with the receiver finder switch and thus simulates the channel letter switch in the remote control unit.

18. The motor-operated "channel letter" segment in the receiver unit is connected to the finder switch in the transmitter control circuit and thus the operation of the manually controlled letter switch in the remote control unit is contrived to operate the finder switches in both the receiver and the transmitter.

12-WAY POTENTIOMETERS

19. The selector motor shaft is geared to a bank of two 12-way potentiometers. These provide for each channel a separate resistance ratio for each tuning motor circuit to function as described in para. 28. This is achieved by the rotation of the 12-ratio potentiometer(s) diagrammatically shown in fig. 2b.

20. Each of the two potentiometer devices includes a resistance winding R, wound on a rod former of pear-shaped cross-section. The rod former is fitted with ball-bearings and rotates on the axis of the circle forming the larger radius of the cross-section as shown in the illustration. The smaller radius, on which the resistance wire is uninsulated, can then touch each of the twelve contacts C in turn when the rod former is rotated. The contacts are each mounted on a tapped nut through which passes a 3-start lead-screw (*fig.* 2b). Each lead-screw can be turned by a preset K.

21. Manual rotation of the preset knob K will cause the contact C to move along the lead-screw and if this is in electrical contact with the resistance winding R, it will vary the resistance ratio of contact lead (2) with respect to ends (1) and (3) of the winding.

22. All the twelve lead-screws are manually rotated in guides which hold them radially at the same distance from the resistance winding R. The lead-screws, and thus the contacts C, are electrically commoned (2) but insulated from the winding R (1 and 3).

23. Since the selector motor rotates the resistance winding on the rod former to touch only one lead-screw contact in each of the twelve positions (corresponding to the chosen channel), the arrangement of the single winding and the twelve contacts

3. The potentiometer driven by the channel selector motor consists of two 12-way potentiometers, either of which can be selected by a manual switch marked "1-2". Each of these 12-way potentiometers is capable of being set to twelve resistance ratios so that when the resistance

bridge is balanced in each of these positions, the tuned circuits controlled by them will be resonant at the chosen channel frequency. The use of two 12-way potentiometers gives 24 resistance ratios for the selection of 24 frequency channels.

4. The channel selection and tuning motor circuits are described in para. 5 to 48. Those circuits connected with the power switch on the remote control unit are described in para. 49 to 93.

REMOTE CONTROL SYSTEM

5. Complete electrical remote control of the transmitting/receiving equipment (and the aerial system—*Sect. 2* and 3) is achieved by using motor-driven channel selector and tuning circuits. The equipment is first set up on the ground and operational frequencies allocated to each of the 24 channels.

6. When a frequency channel is selected at the control unit the selector motors on the control and drive unit of the transmitter and on the receiver will operate and eventually stop at the position corresponding to the chosen channel. The circuit conditions brought about by the operation of the selector motors will cause the tuning motors to operate and finally stop at the position decided by the selector settings.

Note . . .

The control unit Type 4190 is better known as the "control and drive unit" (of the transmitter).

THE SELECTOR CIRCUIT

7. Throughout the equipment the channel designations are given as one of two figures suffixed by one of twelve letters, there being two groups of twelve channels, i.e. 1A to 1M and 2A to 2M. Channel selection, therefore, involves the selection of first one of two "number" positions and then one of twelve "letter" positions, giving 24 channels in all.

8. Reference is made to fig. 2 (a) which is a theoretical version of the selector motor control circuit. Connections from the channel letter switch on the remote control unit are made to the corresponding poles of the 12-position finder switch on the receiver unit.

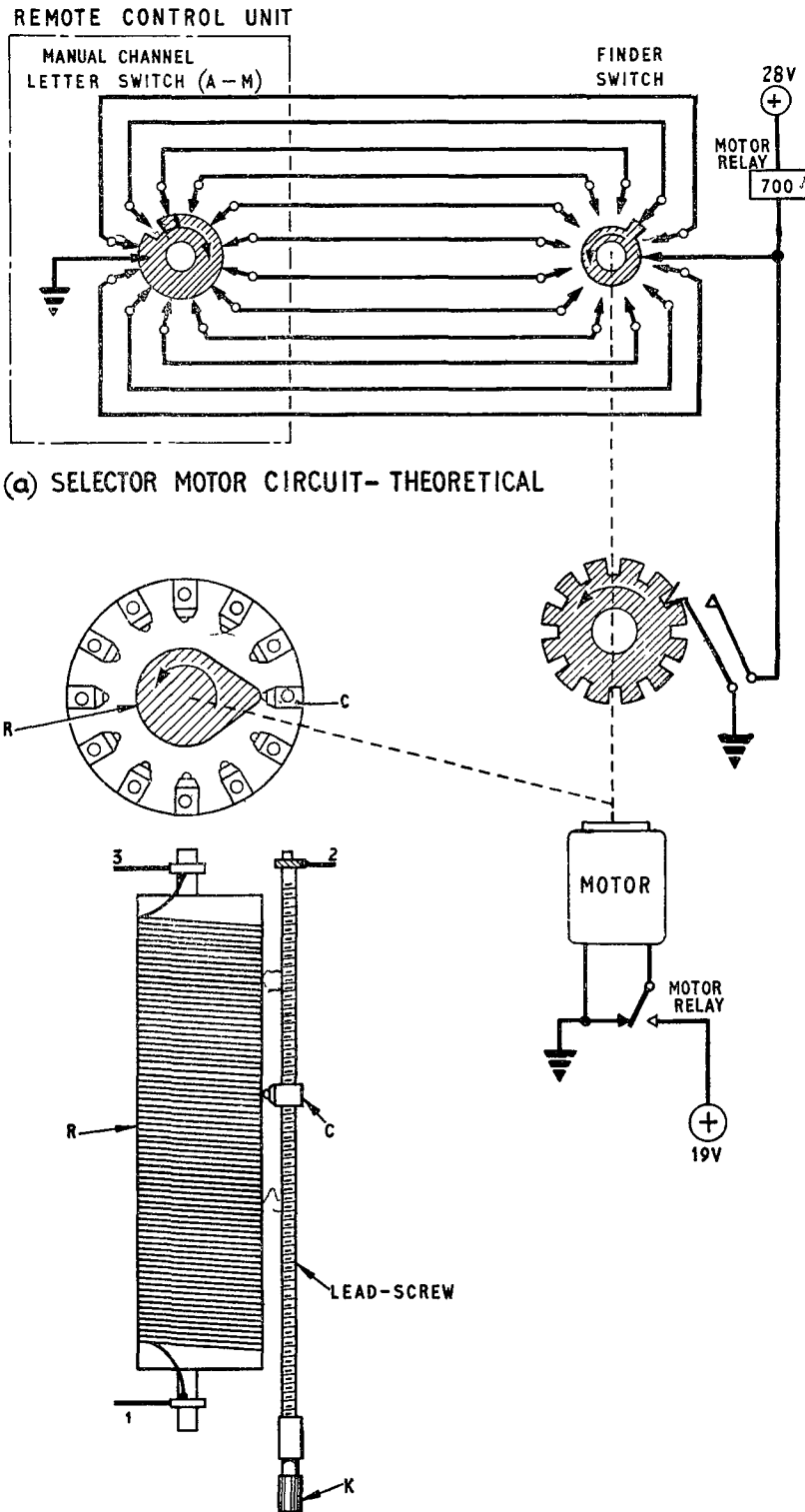

(b) 12-WAY POTENTIOMETER

Fig. 2. Theoretical version of selector motor control circuit

RESTRICTED

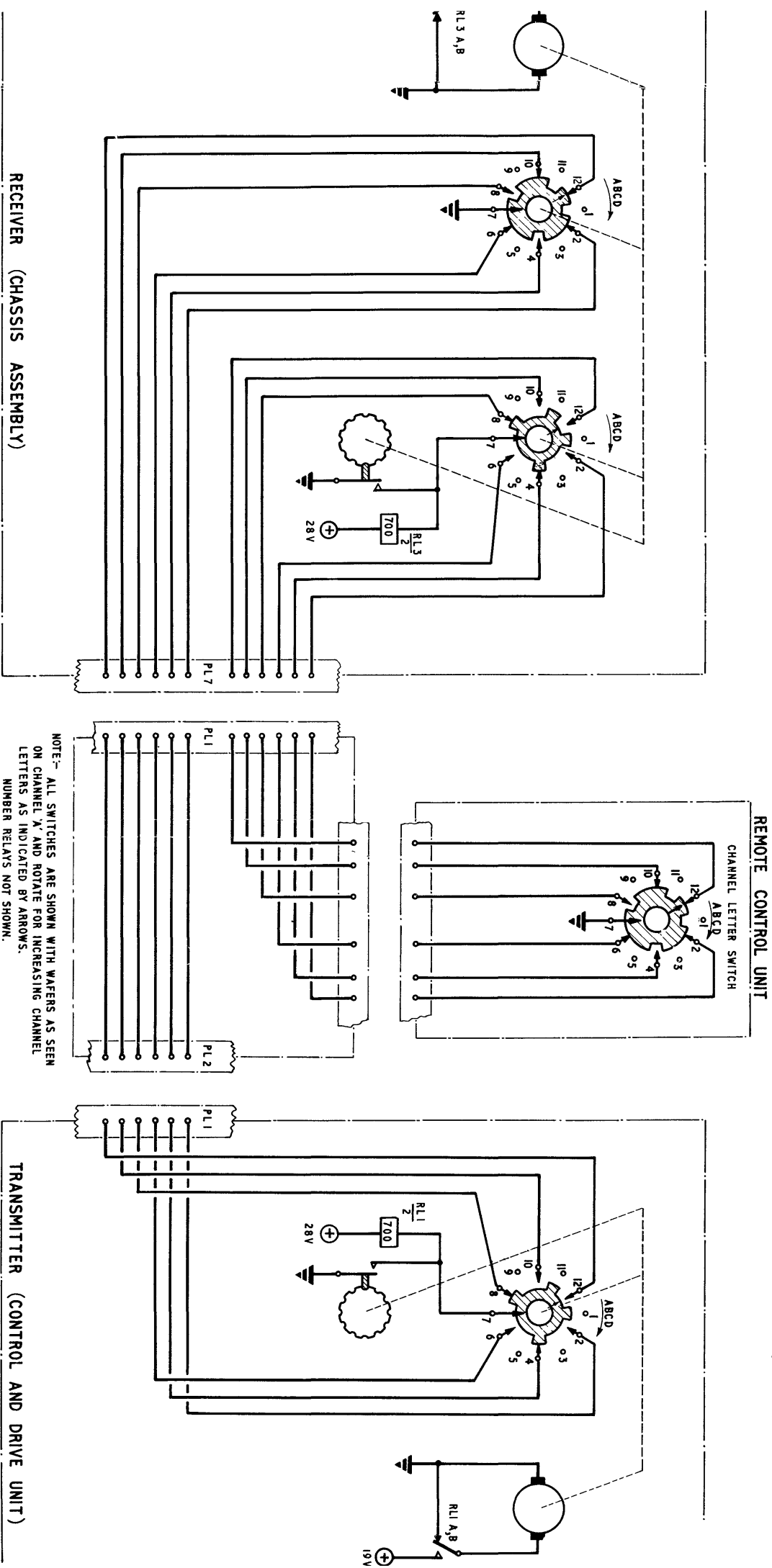

RECEIVER (CHASSIS ASSEMBLY)

REMOTE CONTROL UNIT

TRANSMITTER (CONTROL AND DRIVE UNIT)

NOTE:- ALL SWITCHES ARE SHOWN WITH WAFERS AS SEEN ON CHANNEL 'A' AND ROTATE FOR INCREASING CHANNEL LETTERS AS INDICATED BY ARROWS. NUMBER RELAYS NOT SHOWN.

ARI. 5874 - Channel selection circuits — simplified
R E S T R I C T E D

443765/5375.6.2.5 754 881d Gp 979

Fig. 3
A.L.2, Jun. 54

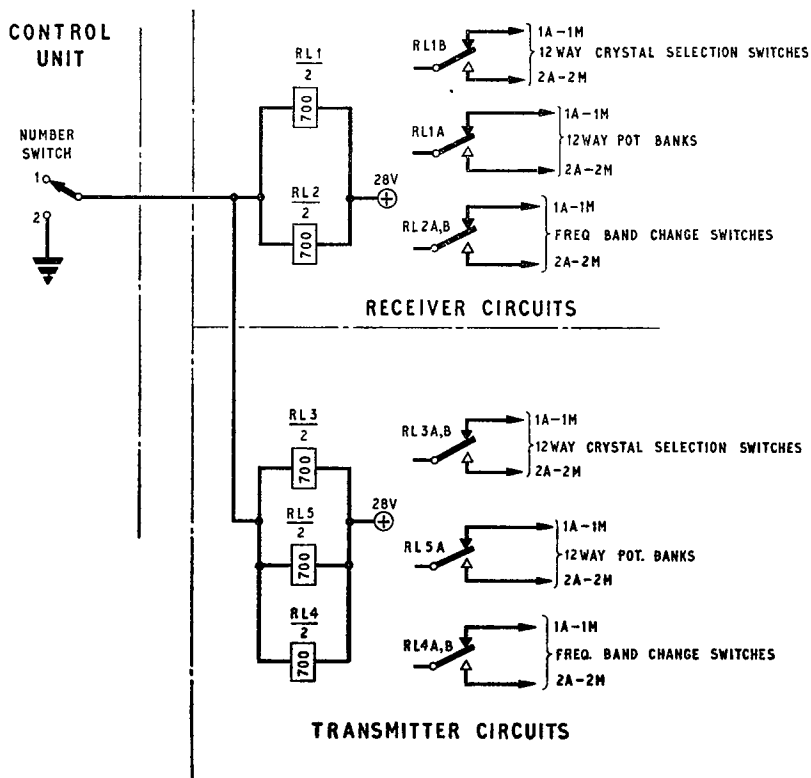

Fig. 4. Simplified circuit of channel number switch and relays

becomes equivalent to twelve separate 3-watt potentiometers, the wipers of which are selected by a single-pole 12-way switch.

24. During the operation of the selector motor(s) the 19V supply to the potentiometers is disconnected by auxiliary contacts on the motor relay. This prevents hunting of the tuning motor(s) as the potentiometers move over the various lead-screw contacts before finally coming to rest at the chosen channel.

functions. The first is to turn the motors by remote control to tune up the equipment from the transmitter drive unit and the receiver. The second is to provide a means of returning to these chosen tuning conditions when selection of a frequency channel is made. The circuit can be described as a "Wheatstone Servo" and is fundamentally a self-balancing resistance bridge (fig. 5a).

TABLE I

The components involved in the circuits of the various items of equipment described in subsequent chapters are given in Table 1.

Component	Control unit Type 4190 (Chap. 3)	Remote Control Unit (Chap. 6)	Receiver (Chap. 2)
Selector motor	MG1	—	MG1
Motor relay	RL1, RL2	—	RL3
Finder switch	S3C	—	S1B
Centering switch	S3J	—	S1G
Manual letter switch	—	S1	—
Letter switch to control unit Type 4190	—	—	S1A
Manual number switch	—	S2	—
Number relays	RL3, RL4, RL5	—	RL1, RL2

SELECTION OF CHANNEL NUMBER

25. A schematic of the circuit of the channel number switch and the number relays is given in fig. 4. With the channel number switch in position 1, the number relays are at rest and the selected channel will be one of those in the range 1A to 1M. The "number" relays have change-over contacts and in either position connect twelve of the crystals, twelve of the band switches and one of the 12-way potentiometers to the channel selector switches.

26. When the channel number switch is placed in position 2 the number relays are energized and the relay contacts change-over. In this position of the contacts the letter selector switches are connected to the alternative 12 crystals, the alternative 12-band switches and the second of the two 12-way potentiometers.

TUNING MOTOR CIRCUITS

27. The circuit used to drive the tuning motors has two

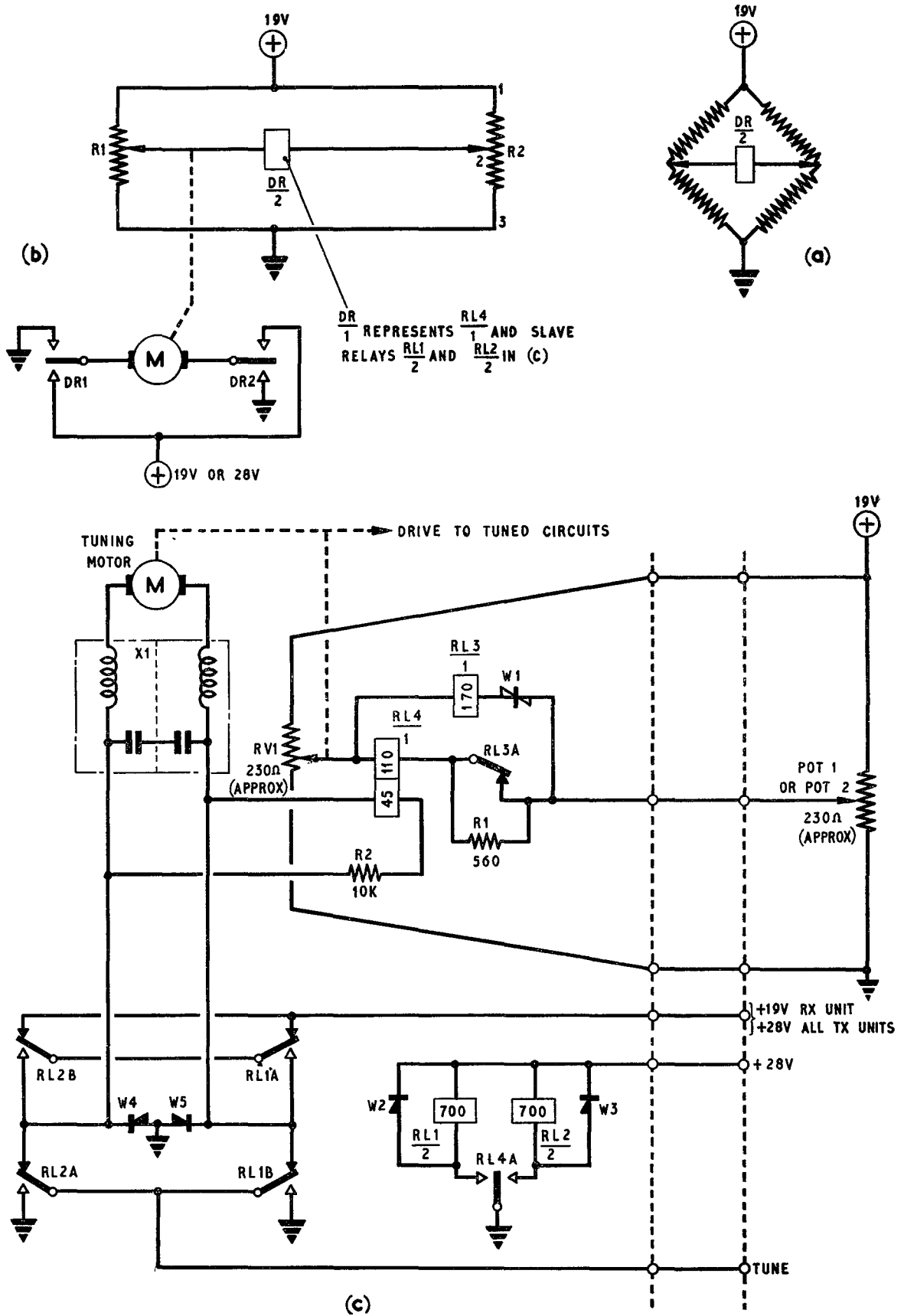

Fig. 5. Simplified circuit of remote control tuning system

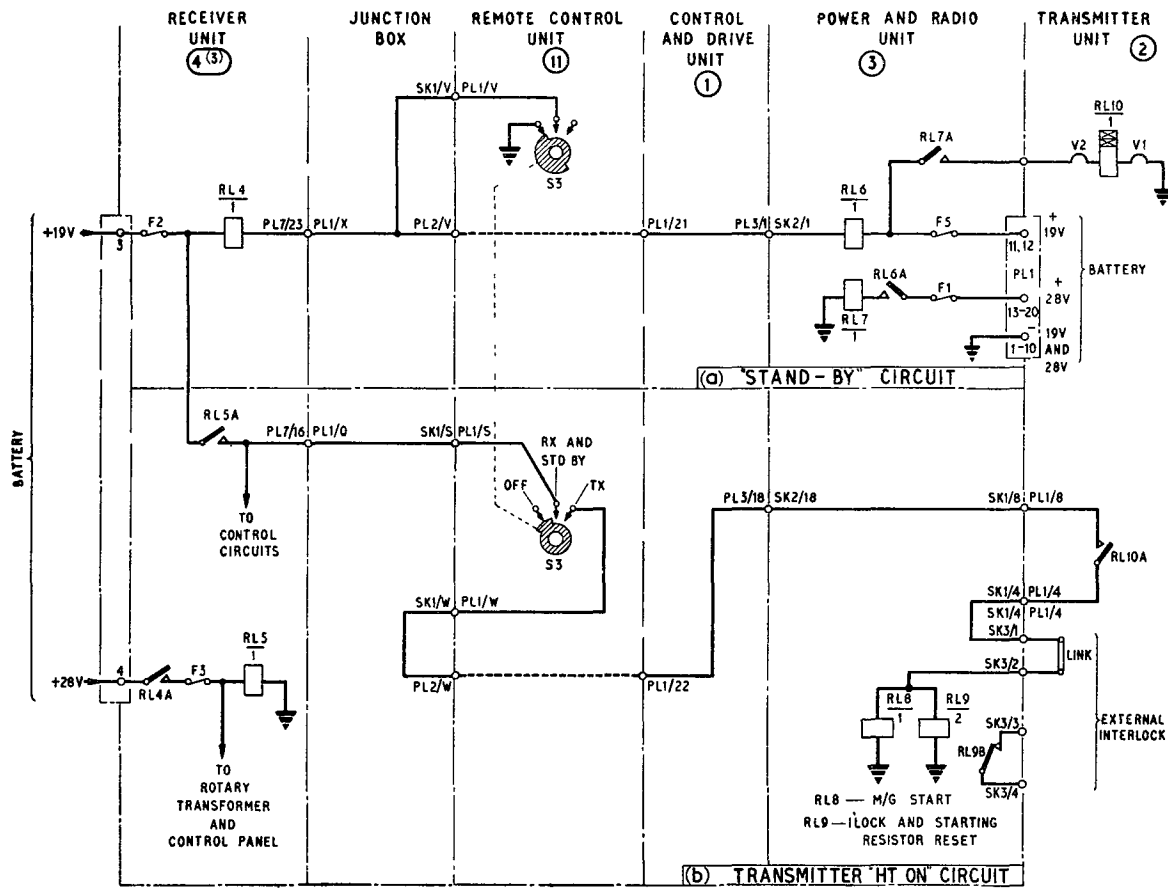

Fig. 6. Simplified "Standby" and transmitter "HT ON" circuit

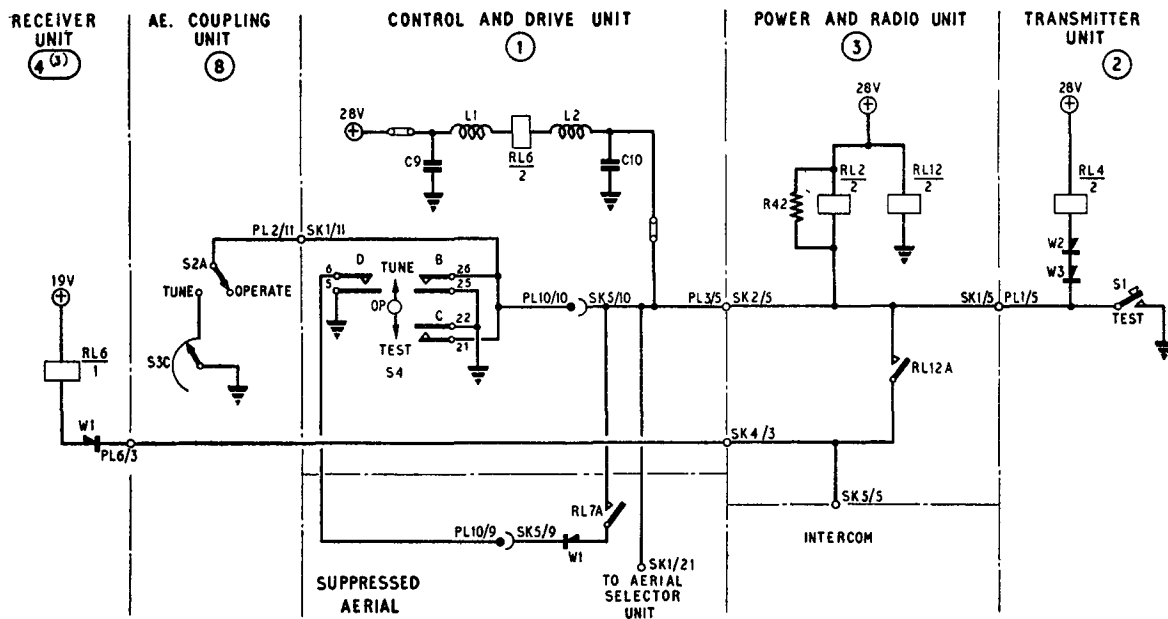

Fig. 7. Simplified key circuit

RESTRICTED

28. Reference is made to the simplified tuning control circuit in fig. 5b. The bridge circuit consists of a potential divider R2 representing a setting on one of the 12-way potentiometers. This is connected to the potentiometer R1 of the tuning motor assembly.

29. The two potentiometers form a Wheatstone bridge as shown in the diagram, energized from the 28V supply and having a centre stable relay DR/2 as a detector. The wiper of R1 is mechanically driven by the tuning motor M.

30. When the bridge is unbalanced the relay DR/2 is operated by the out-of-balance current and the contacts DR1 and DR2 move from the centre position (fig. 5b). The direction in which the contacts move and consequently the polarity of the voltage applied to the tuning motor, is dependent upon the direction in which the potentiometer R2 is off-set, i.e. the current flow through relay DR/2 will be either from R1 to R2 or R2 to R1, dependent upon the direction of movement of R2. Thus the overall system will always take the shortest route to achieve the balanced condition.

31. Any new position of the wiper R2, that is, a movement of the channel knob on a 12-way potentiometer, causes the bridge to unbalance and the motor to drive to the new balance condition. The travel of the wiper of R2 over the full length of the resistance winding will therefore cause the motor to rotate through a definite number of revolutions; this rotation is geared to drive the associated tuning elements to any corresponding position.

32. Considering the practical case, the circuit for all tuning motors is as shown in fig. 5c. The setting potentiometer POT. 1 (or POT. 2) is coupled by cables to the motor-balancing potentiometer RV1. The bridge is supplied with 19V except when the equipment is in the MANUAL condition and when the selector motors are running.

33. A separate earth wire on the bridge, earthed at one end only, is used to avoid other DC earth currents affecting the centre stable relay RL4/1.

34. The wiper of POT. 1 is taken through the relay contact RL3A to the 110-ohm winding of the sensitive relay RL4/1, and thence to the wiper of RV1 driven by gearing from the tuning motor M.

35. When the bridge is unbalanced, relay RL4/1 operates and closes contact 4A. Since the contacts of this relay cannot handle the motor current, contact 4A is arranged to energize the slave relays RL1/2 and RL2/2 from the 28V supply.

36. If the unbalance of the bridge is such that the direction of movement of contact 4A causes the relay RL1/2 to be energized, contacts 1A and 1B close. The 19 V supply is then taken via contacts RL2B and RL1A to one side of the motor M which being earthed on its other pole via contacts RL2A and RL2B starts to rotate.

Note . . .

The supply to the bridge circuit and tuning motor of the receiver circuits is 19V. In the transmitter and aerial circuits the supply to the tuning motors is 28V.

37. When the bridge is restored to its balanced condition, contact 4A returns to the centre position and relay RL1/2 is released. Contact 1B then short-circuits the motor armature thus providing a braking action to prevent over-run of the motor; the motor has a permanent magnet field.

38. If relay RL2/2 is energized by reason of the position of the relay contact 4A, the contacts 1A and 2B will apply the 19V supply to the motor in the reverse direction to that described in para. 36. The direction of the rotation of the motor will then, of course, be reversed.

39. Since the sensitive centre stable relay RL4/1 operates with an energizing current of approximately 200 microamperes, the 110-ohm winding must be protected from overload when the bridge is well out of balance. A non-linear resistance W1 is connected in series with the safety relay RL3/2 and both are connected across the 110-ohm winding of RL4/1. In conditions of overload the non-linear resistance falls to a low value and sufficient current passes to energize the safety relay, thus opening contact 3A and placing the resistor R1 in series with the sensitive winding to protect it.

40. At near balance conditions the contact 3A closes and thus restores the centre stable relay to its full sensitivity.

41. The relay contact 4A is protected by the spark quench rectifiers W2 and W3, which also slow the release of the slave relays RL1/2 and RL2/2. The spark quench rectifiers W4 and W5 are connected across the motor to protect the contacts 1A, 1B, 2A and 2B.

42. Unless certain precautions are taken (para. 43), the system as described in the foregoing paragraphs will tend to "over-shoot" the balance point and then hunt before coming to rest. "Over-shoot" and the consequent hunting is prevented by the inclusion of an "anti-hunt" circuit using a 45-ohm second winding on the centre-stable relay RL4/1. This will be described as a "feedback" circuit, although the action is not as is generally understood by this term.

43. Assume that the motor is moving towards the balance point with the contact 1A closed; the positive potential at the motor pole (relay contact 1A) is applied through the second winding of 45-ohm on relay RL4/1 through the feedback resistance R2 to earth at 2B. The mode of action of the 45-ohm winding is in opposition to that of the detector winding so that relay RL4/1 will reach its neutral position to stop the motor before the actual balance point is obtained. In this condition, the feedback winding no longer has any effect since the positive supply is removed by the movement of relay contact 1A, however, the out-of-balance current still flows through the 110-ohm winding because the balance point is not yet reached.

44. The sensitive relay RL4/1 thus closes once again to indirectly operate relay contact 2B but as the effect of the 45-ohm winding is now greater the contact is immediately thrown off. These conditions are repeated until the unbalance current falls below the operating value of the 110-ohm winding of RL4/1 and thus equilibrium is reached.

RESTRICTED

45. If the motor had been energized through the closed relay contact 2B, the feedback direction would then have been from 2B to 2A, thus still in opposition to the action of the 110-ohm winding. In practice, this causes the slave relays to run the motor to a point just before balance and then "tick" into the rest position. If overshoot occurs owing to varying loads on the motor, the feedback circuit greatly reduces the duration of hunting.

46. "Hash" filters are fitted to each pole of the tuning motor and are enclosed in a screened box X1. When the motor is running one of the contacts 2A or 1B of the slave relays will be operated and will earth the TUNE line (*fig. 5c.*) This indicates on a "TUNE" lamp on the remote control unit that a tuning motor is operating and

normally prevents the key placing the transmitter on "mark". The latter function is more fully described in para. 86.

47. To prevent the control system driving the motors until the mechanical rotation "limit-stops" on the associated driven components are reached, it is necessary to arrange electrical stops inside the rotation limits. This is achieved by limiting the wiping length of the 12-way setting potentiometers in such a way that a small portion of the resistance is always left in circuit. The limitation ensures that the balancing potentiometer RV1 will always reach balance before the end of its travel.

48. The components used in the bridge circuits are tabulated against the function of tuning motors in the table below.

TABLE 2

Function of Tuning Motor		Component Reference					
		12-way POT	Motor	Balancing Pot	Slave Relays	Detector Relay	Safety Relay
Transmitter	RF Stages	1 POT. 1 (1A-1M)	2MG1	2RV1	2RL8	2RL6	2RL7
		1 POT. 2 (2A-2M) (Control unit Type 4190 or 4243)			2RL9		
Receiver	RF Stages	4 (3) POT.1 (1A-1M) 4 (3) POT.2 (2A-2M)	4 (2) MG1	4 (2) RV1	4 (2) RL1 4 (2) RL2	4 (2) RL4	4(2) RL3
Aerial coupling unit (wire aerial) (See Sect. 3)	Coupling circuits	1 POT.3 (1A-1M)	8MG1	8RV5	8RL3	8RL6	8RL5
		1 POT.4 (2A-2M)			8RL4		
		1 POT.5 (1A-1M)	8MG2	8RV4	8RL7	8RL10	8RL9
		1 POT.6 (2A-2M)			8RL8		
		1 POT.7 (1A-1M)			8MG3		
1 POT.8 (2A-2M)	8RL12						

CONTROL AND SWITCHING CIRCUITS

49. The following description concerns the control and power switching of the transmitter and receiver circuits to the exclusion of the aerial circuits. Those circuits affected by the service switch on the remote control unit are described in Chap. 6. The control and switching of the aerial circuits is described in Sect. 2 (suppressed aeriels) and Sect. 3 (wire aeriels).

"STANDBY" CIRCUIT

50. The equipment will be put to "Standby" before HT is switched on (*para. 55*), and the switch S3 on the control unit must pass through this position (S/BY) before transmitter HT is switched on (position TX).

51. In the simplified "Standby" circuit in *fig. 6A* the equipment is shown in the OFF position. When S3 is put to S/BY, relay 4 (3) RL4/1 in the receiver is energized from the 19V supply.

This relay is known as the "28V ON" relay and its contact applies the 28V supply to the rotary transformer and to the control circuits of the receiver.

52. A second relay 4 (3) RL5/1 is also operated by contact 4A and supplies 19V (via contact 5A) to the remainder of the control circuits of the receiver.

53. The connection to relay 4 (3) RL4/1 on the receiver is via the junction box at the points shown on the simplified circuit (*fig. 6A*).

54. Relay 3RL6/1 is also energized when the switch S3 is in the S/BY position. The contact of this relay connects the 28V supply to the control circuits in the power and radio unit. The same contact causes a second relay (3RL7/1) to be energized, the contact of this relay (7A) connecting

Suppressed aerial operation

66. When suppressed aerial equipment is used the key line is taken as shown in fig. 7 to 1SK1/21 on the control and drive unit and thence to the aerial selector unit (*Sect. 2*) where it is earthed by the "TUNE-TEST" switch. Additionally, relay contact 7A closes to key the transmitter when 1RL7/2 (*fig. 6a*) is energized with the aerial selector unit in the TUNE condition.

Wire aerial operation

67. When an open wire aerial is used the key line is taken as shown (*fig. 7*) from PL10/10 to 1SK1/11 and thence to the aerial tuning unit of the wire aerial equipment. Here it is earthed when the TUNE/OPERATE switch 8S2 is in the TUNE position; this facilitates manual checking of the aerial tuning unit from its front panel.

68. Relay 1RL6/2 is the "low impedance" aerial changeover relay, which changes the aerial connection from the receiver on "space" to the transmitter on "mark" when the key is operated.

19V SUPPLY CIRCUIT FOR SUPPRESSED AERIAL OPERATION

69. The regulated positive 19V supply enters the equipment at two points. One on the receiver at 4PL5/3 and another on the power and radio unit at 3PL1/11-12. The negative 19V pole is earthed. A simplified diagram of the 19V circuit is given in fig. 8.

70. Starting at the input to the receiver, the positive 19V supply is applied through the fuse F2 and the relay contact 5A. Relay 4RL5/1 is energized when the 28V supply (*para. 77*) is applied to the receiver control circuits; contact 5A then applies the 19V supply to the receiver control circuits at the point marked in the circuit (*fig. 8*). These circuits include supply to the valve heaters and relays, etc.

71. The 19V supply is also taken via 4PL7/16 and 11PL1/S to the remote control unit where it supplies the dial lamp LP1 via the dimmer resistor RV2.

72. From the same point (11PL1/S) the 19V supply is applied, via 11R1, to the fine tuning potentiometer 11RV1.

73. The 19V connection to the power and radio unit is taken via points PL1/11-12 and fuse 3F1 to operate relay 3RL6/1 when the equipment is at "Standby". Relay contact 3RL7A is closed by the 28V supply (*para. 78*) and connects the 19V supply to the following circuits:—

(1) The audio amplifier (modulator) valve heaters via 3SK6/4.

(2) The PA stage heaters via the dropping resistor 3R41, 3SK1/24 and 2SK1/2 to 2V3 and 2V4 in series.

(3) The heaters in the transmitter via 3SK1/27 to 2V1 and 2V2. Relay 2RL10/1 is the heater time delay relay with contacts in the "HT ON" circuit (*para. 51*).

(4) Through the 19V control circuit fuse 3F2 via 3SK2/14 to control and drive unit. Here it supplies the valve heaters of the crystal oscillator at 1SK4/1; and motor MG1 from PL3/14 via contact 1RL1A. The bridge potentiometers 1POT.1 and 1POT.2 are supplied via contact 1RL2/B. (LP1 and S4A).

(5) The 19V supply is also taken out through 1SK1/22 to the suppressed aerial selector unit (*Sect. 2*).

19V SUPPLY CIRCUIT FOR WIRE AERIAL OPERATION

74. In this installation the 19V supply circuit to the receiver is identical to that described above (*para. 69*).

75. In the transmitter the circuit is again identical as far as the transmitter and power and radio unit are concerned.

76. In the control and drive unit a further supply is taken via 1SK1/1 and 8PL2/1 to the aerial tuning unit (*fig. 8*). Here it is connected by 8S1B in the MANUAL position to the warning lamp 8LP1 and in the AUTO position via 8LP2/7 and the closed relay contact 1RL2A to the "bridge" supplies of the aerial tuning circuits.

28V SUPPLY CIRCUIT FOR SUPPRESSED AERIAL OPERATION

77. A simplified diagram of the 28V supply circuit is given in fig. 9. The positive 28V supply enters at the receiver and the power and radio unit. The negative 28V line is earthed.

78. The input to the receiver is at 4PL5/4, through the relay contact 4RL4A, which closes from the 19V circuit when the receiver is in the ON condition, and thence:—

(1) Direct from the relay contact to the receiver rotary transformer.

(2) Through the control circuit fuse 4F3 to relay circuits and crystal oven heater circuit. The relay contact 4RL7A switches the heater R1 of the crystal oven.

79. The 28V input to the power and radio unit is at plug points 3PL1/13-20 and supplies the following circuits:—

(1) The rotary transformer 3MG1 is supplied via the TX relay contact 3RL8A (the starting circuit is described in *Chap. 5*).

(2) In the circuit through the 28V control fuse 3F1 the relay contact 3RL6A is closed when the equipment is in the "Standby" condition. The relay is operated from the 19V circuit (*para. 73*). The connection through the relay contact energizes the remaining 28V circuits of the transmitter.

(3) In the power and radio unit, the circuits supplied from fuse 3F1 are the relays 3RL2, 7 and 11 and the associated resistor 3R42 (*fig. 7*), the bias supply of the modulator valves 3V5-6-7-8 the cathodes of which are connected to the 28V supply via the relay contact 3RL3A.

RESTRICTED

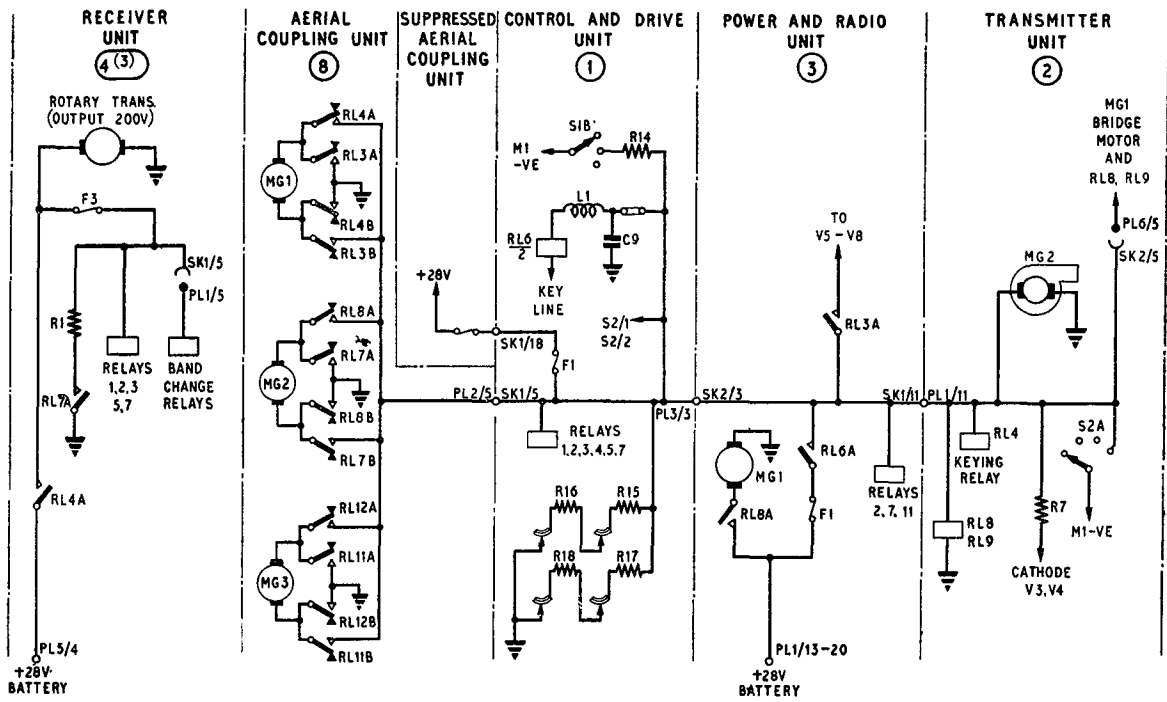

Fig. 9. Simplified 28V circuit

(4) The 28V supply enters the transmitter at 2PL1/11 to:—

- (a) Operate the blower motor 2MG2.
- (b) Provide bias for the P.A. valves 2V3 and 2V4 by connection of their cathodes through bias resistor 2R7.

(c) Supplies 28V positive to the meter switch S2.

(d) Supplies the tuning motor 2MG1 and the slave relay 2RL8/2 and 2RL9/2.

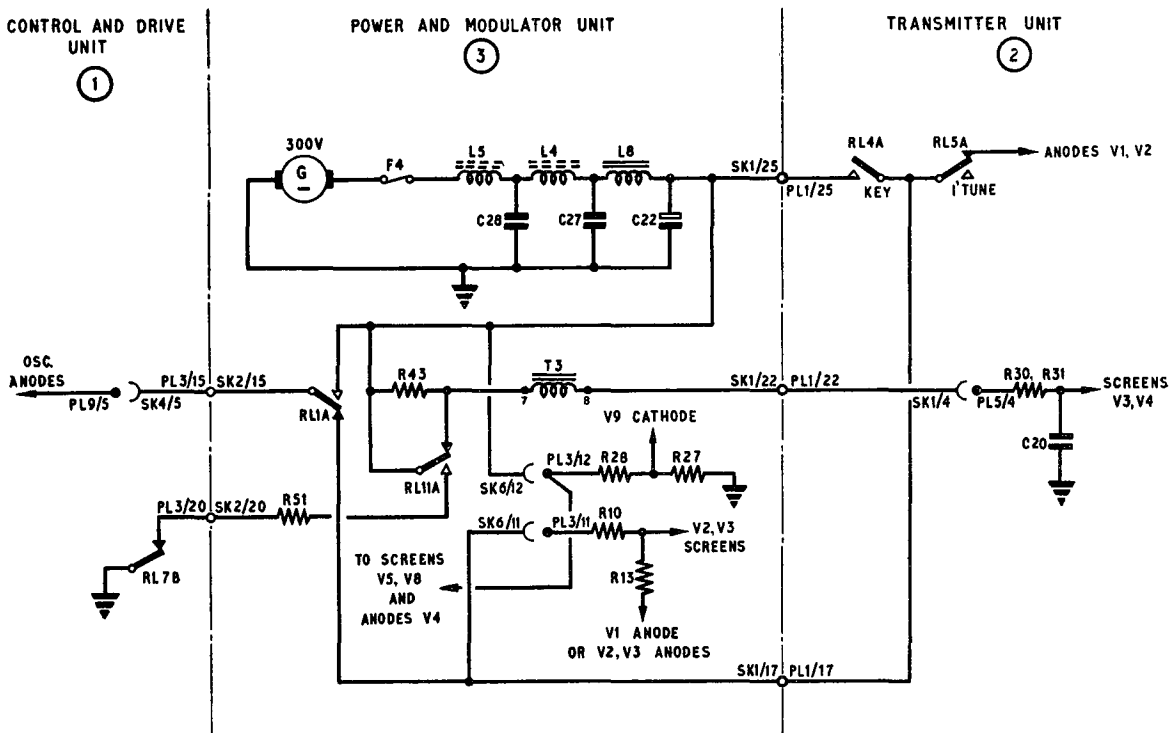

Fig. 10. Simplified 300V circuit

(5) The 28V supply is also taken to the control unit Type 4190 via 3SK2/3 and 1PL3/3. Here it divides as follows:—

- (a) To the band switches 1S2/1 and 1S2/2.
- (b) To the "low impedance" aerial change-over relay 1RL6/2 on the key line.
- (c) To the metering circuit of 1S1 via resistor 1R14.
- (d) To the suppressed aerial coupling unit via fuse 1F1 and 1SK1/18.
- (e) To relays 1RL1-2-3-4-5-7 and to crystal oven heaters 1R15, 1R16, 1R17 and 1R18.

28V SUPPLY CIRCUIT FOR WIRE AERIAL OPERATION

80. The 28V supply to the receiver circuits is identical to that of the suppressed aerial installation (*para.* 78).

81. In the transmitter circuits the connections are as for the suppressed aerial installation (*para.* 79); with the exception of an additional connection from the control unit Type 4190 to the aerial tuning unit (1SK1/5 to 8PL2/5) where it supplies the motor relays.

300V HT CIRCUIT FOR TRANSMITTER ONLY

82. A simplified diagram of the 300V circuit is given in fig. 10. The negative pole of the 300V winding of the HT rotary transformer in the

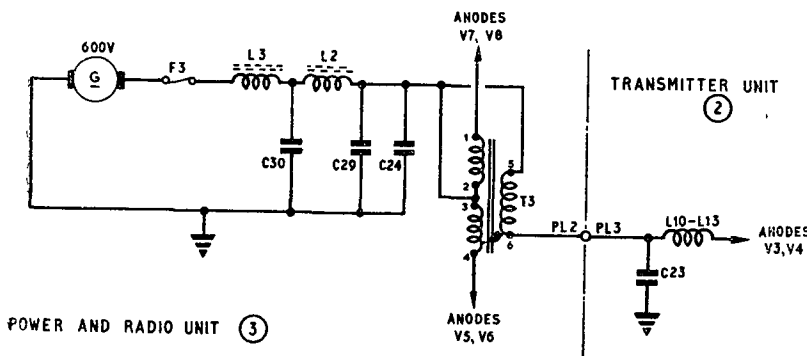

Fig. 11. Simplified 600V circuit

power and radio unit is earthed. The positive pole is protected by the 500 mA fuse 3F4 and the supply is filtered by the RF "hash" filters 3L5, 3C28, 314 and the ripple filter 3L8 and 3C22. The 300V supply is then distributed as follows:—

(1) To the anodes of the crystal oscillator in the control unit Type 4190 via relay contact 3RL1A and points 3SK2/15 and 1PL3/15. Relay 3RL1/2 is energized in INTERTUNE position only.

(2) Provide the modulated screen supply of the P.A. valves 2V3 and 2V4, through 3R43, a secondary winding of the modulating transformer 3T3 and points 3SK1/22 and 2SK1/4. Resistor 3R43 is short-circuited by 3RL11A except when the equipment is in the TUNE position of 1S5 for setting up a channel.

(3) To the anodes of V4 and screens of V5, V6, V7 and V8 the audio amplifier via 3SK6/12.

(4) To the keying relay 2RL4A via 3SK1/25 and thence to the anodes of 2V1 and 2V2. Also from the keying relay via PL1/17, relay contact 3RL1A, 3SK2/15 to the crystal oscillator and cathode-follower anodes of 1V1, 1V2, 1V3. A branch of the latter keyed supply is taken to the anodes of tone oscillator (MCW) 3V1 via 3SK6/11. When the equipment is in the INTERTUNE condition, relay contact 2RL5/A breaks the supply to the transmitter valves 2V1 and 2V2.

(5) Under "LOW POWER" conditions contact 3RL11A opens the circuit across resistor 3R43 but adds 3R51 to earth via 3SK2/20, 1PL3/20 and contact 1RL7B. In the "TUNE" or "SAFE" condition, contact 1RL7B opens and leaves 3R43 in circuit as a screen current limiting resistance.

600V HT CIRCUIT FOR TRANSMITTER ONLY

83. A simplified drawing of the 600V circuit is given in fig. 11. The negative pole of the 600V winding of the rotary transformer is earthed. The positive output is applied through the 1-amp fuse 3F3 and the hash filter 3L3, 3C30, 3L2 and 3C29. Ripple filtering is provided by 3C24.

84. The 600V line is connected to the anodes of the modulating valves 3V7, 3V8 and 3V5, 3V6, connected in parallel push-pull through the centred-tapped primary winding of transformer 3T3. The anodes of the P.A. valves of the transmitter are connected to the 600V line via the secondary winding of 3T3 points 3PL2 and 2PL3 and chokes 2L10-2L13. A separate cable from 3PL2 to 2PL3 is used for this modulated 600V supply.

INTERTUNE/TUNE CIRCUIT

85. The following description of this circuit is made with reference to the simplified circuit given in fig. 12. The function of the circuit is described before the connections are traced.

"TUNE" line

86. Earthing the "TUNE" line performs the following functions:—

- (1) Lights the "TUNE" lamps on the receiver (4LP1) the remote control unit (11LP2) and on the control unit Type 4190 (1LP1) whenever any of the selector motors or tuning motors are operating.
- (2) Puts the transmitter in the INTERTUNE condition i.e. "key up" condition, except for the crystal oscillator.
- (3) Mutes the receiver except under INTERTUNE conditions.

Note . . .

Condition (2) allows the key to be on mark with safety while a channel is being selected.

RESTRICTED

Circuit of "TUNE" line with transmitter and receiver ON

87. From the receiver at 4PL7/18 this line is connected via point 11PL1/H, switch segment 11S4C, point 11PL1/J to 1PL1/17. From the control unit Type 4190, the line passes :—

- (1) Via 1PL3/10 to the power and radio unit at 3SK2/10 to the relay 3RL1 and thence to the TUNE relay 2RL5 in the transmitter.
- (2) To the lamp 1LP1 and the motor relay contacts 1B in the control and drive unit.

contacts 4 (2) RL1B, 4 (2) RL2A, 4 (3) RL3B, 2RL8B, 2RL9A, 1RL1B or by relays in the units of the aerial system. This causes all the TUNE lamps to glow, i.e. 4LP1, 11LP2, 1LP1 and the relays 3RL1 and 2RL5 to operate.

91. The relay 3RL1 connects 300V positive to the crystal oscillator via contact 1A, and biases back the modulator valves by use of the relay contact 3RL1A. Relay 2RL5 removes the 300V positive supply from the anodes of the valves 2V1

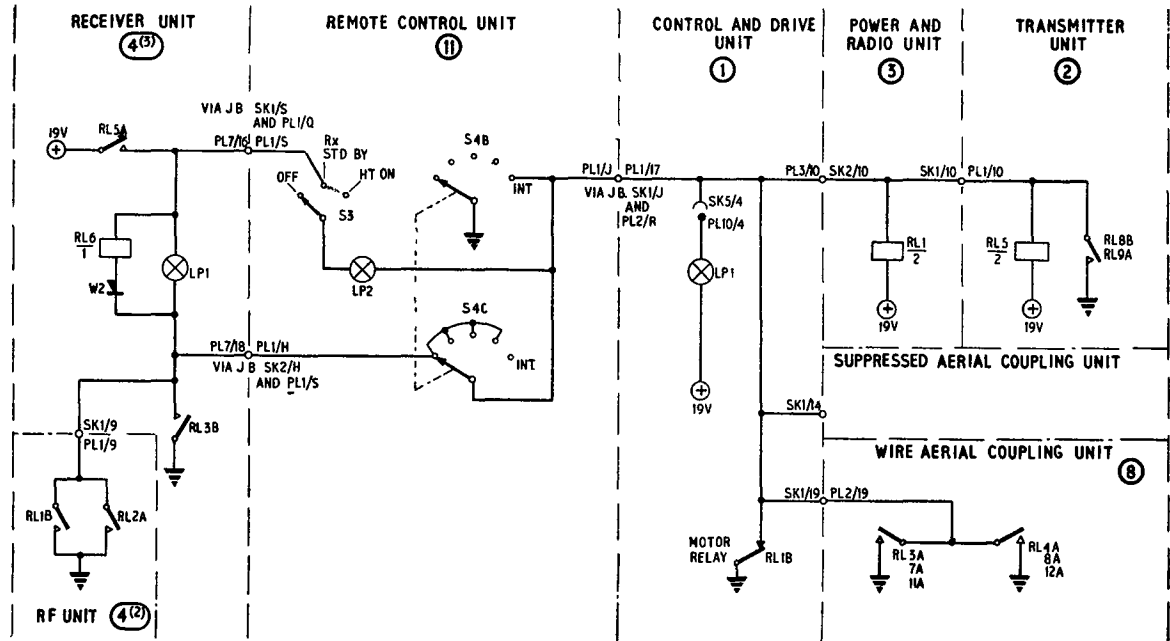

Fig. 12. Simplified INTERTUNE/TUNE circuit

Suppressed aerial operation

88. In installations with suppressed aerials the connection from the control and drive unit is connected via point 1SK1/14 to the suppressed aerial selector unit. (Sect. 2). This line is earthed during any tuning operation in the suppressed aerial equipment.

Wire aerial operation

89. Installation with fixed wire aerials have a connection from the control and drive unit via point 1SK1/19 to 8PL2/19 and thence to the motor relays in the aerial coupling unit.

90. This line is earthed by the operation of any of the tuning or selector motors i.e. by relay

and 2V2 by means of the contact 5A and biases back the P.A. stage by means of contact 5B.

92. Relay 4RL6 operates and mutes the receiver by removing the cathode return to earth on the RF unit at contact 6A. When the remote control unit switch is in the "INT" (intertune) position, the tune lamps operate continuously (11S4B) but switch segment 11S4C breaks the TUNE line to point 11PL1/11 and thus the muting relay 4RL6 cannot operate when the receiver is tuning.

93. This relay also operates when the "key line" is earthed and again mutes the receiver. Rectifier 4W2 is used to prevent the TUNE lamps, etc. operating in this condition.

Chapter 8

VOLTAGE REGULATOR 5UC/6010

LIST OF CONTENTS

	Para.
General description	1
Circuit description	5
Setting-up and operation	12

LIST OF ILLUSTRATIONS

	Fig.
Voltage regulator (5UC/6010)	1
Interior view	2
Voltage regulator—circuit	3

GENERAL DESCRIPTION

1. The voltage regulator 5UC/6010 is approved for use in aircraft where a stabilized 19V supply is required for heater and relay circuits of aircraft radio equipments. The input to the regulator is from the normal aircraft supply which may vary between 22 and 29 volts.

2. The regulator is approved for use with ARI.5874 but should not be treated as an integral part of the ARI.5874 since this installation may be wired into whatever 19V supplies are available in the particular aircraft. The regulator will supply $19V \pm 1V$ over an output range of 5 to 25 amp. The output voltage may be varied over a restricted range from the front panel while in use.

3. The unit is self-contained, chassis built and enclosed in a dust cover. It is designed for standard rack mounting (*Chap 10*) and for this purpose is supplied with back-plate cable connections.

4. On the front panel (*fig. 1*) are mounted the voltmeter and the following controls:—

- LIGHT A push-pull switch to switch the internal illumination of the voltmeter.
- CHECK ON A press-release switch for output level test.
- SET ON A press-release switch for output level adjustment.
- ADJUSTVOLTS An arbitrary calibrated scale and knob mounted on the controlling volts potentiometer, the scale of which can be locked in any desired position by a locking device.

CIRCUIT DESCRIPTION

5. The voltage regulator is fundamentally a variable resistance of the carbon pile type controlled by an electro-magnet energized from the output circuit. The carbon pile resistance CP1 (*fig. 2*) is connected in series between the DC supply provided by the aircraft and the load, such as heaters

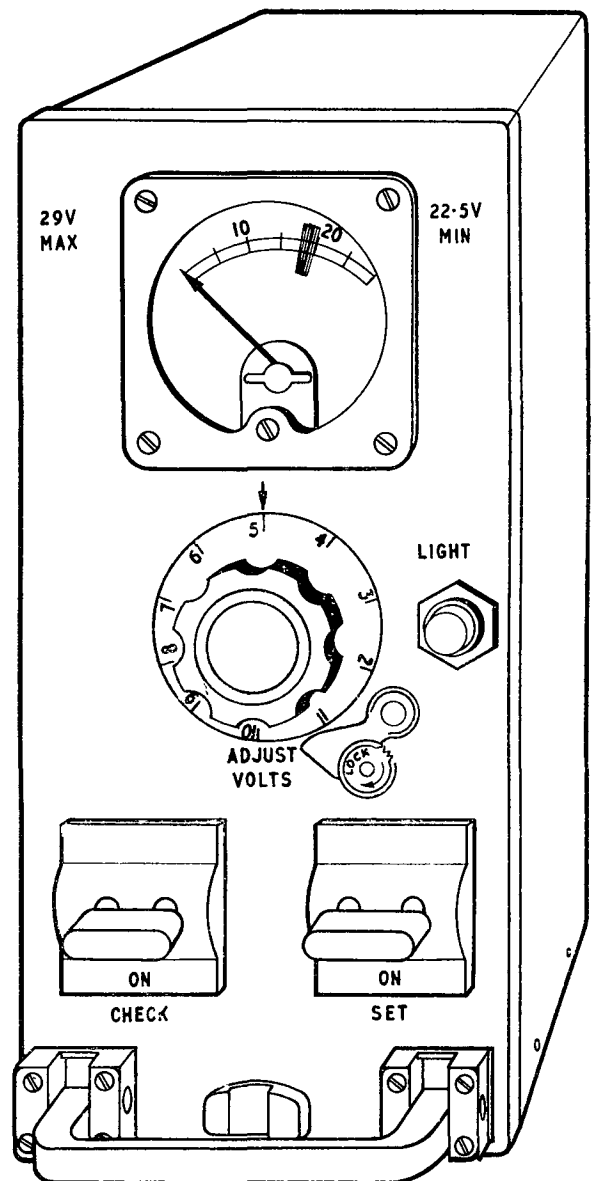

Fig. 1. Voltage regulator (5UC/6010)

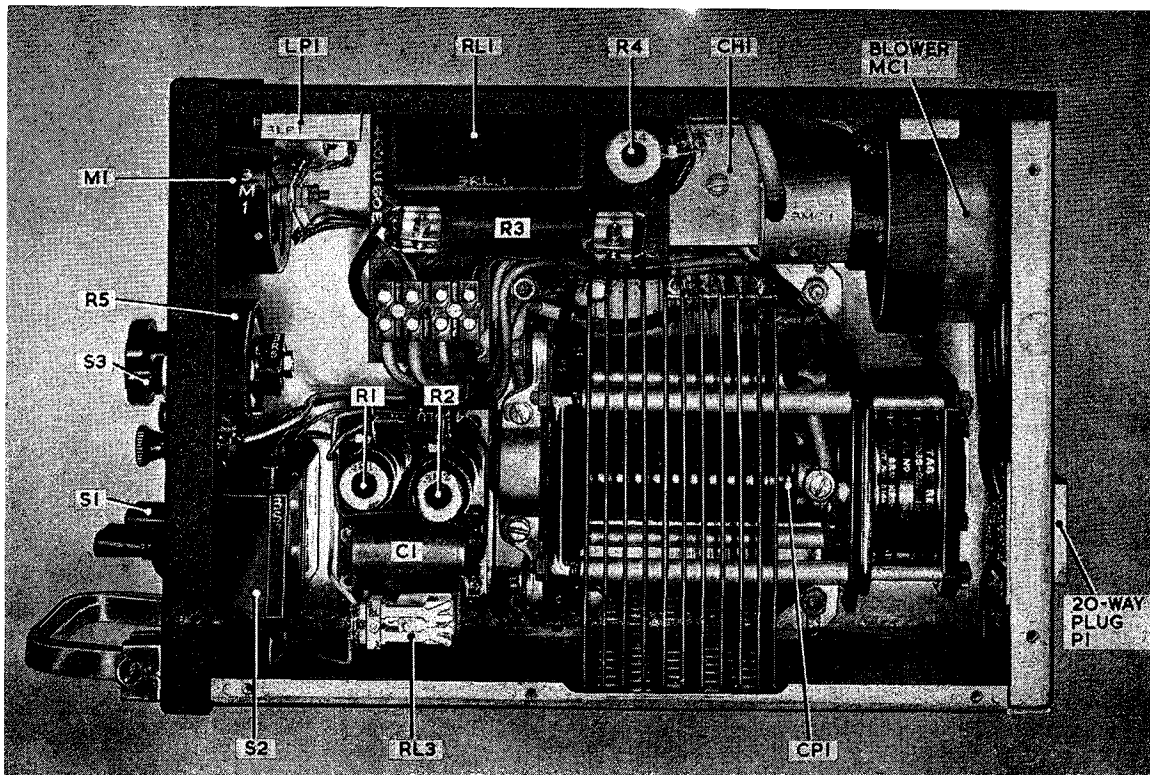

Fig. 2. Interior view

and relays, etc. The electro-magnet is so proportioned that as the battery voltage varies from 22-29 volts, the voltage across these heaters, relays, etc. remain substantially constant at 19 volts. To dissipate the heat generated in the carbon-pile, a cooling fan (MC1) is provided.

6. Reference to fig. 3 will show that when the aircraft positive supply is fed to the carbon-pile (via P1 pins 1 to 7) the main output relay (RL1) is energized. One pair of its contacts RL1/1 and RL1/1A are used to connect a resistor R3 in parallel with the carbon-pile. The object of this resistor is two-fold (1) it acts as a spark quench for the carbon-pile if the output current is of too low a value; (2) it modifies the resistance characteristics of the carbon-pile.

7. To verify that the carbon-pile is functioning properly, two test switches are provided on the front panel SET (S2) and CHECK (S1) the action of which are as follows.

8. When the SET switch is operated a resistor R2 is connected as a load to the output and the output voltage adjusted by the front panel control ADJUST VOLTS (R5) to read on the voltmeter (M1), say 19 volts.

9. If now the CHECK switch is operated, an additional resistor R1 is inserted in series with the carbon-pile and the load R2, thus dropping the voltage on the carbon-pile, which should then re-adjust itself so that the output voltage is substantially the same as when the SET switch was used.

10. Relay RL3 operates in the check and set circuit, whilst relay contacts RL1/3 and 3a operates the "blower" mechanism MC1 via filter CH1.

11. In the output circuit the ADJUST VOLTS R5 is the final control and variable resistor R4 the coarse control, the latter has been set at the factory for greatest efficiency and it should not be necessary to make any further adjustment.

SETTING-UP AND OPERATION

12. The voltage regulator functions with a 22-29 volts DC supply and delivers a supply of 19 volts for equipment requiring a stabilized voltage for heater and relay circuits etc., with special application to aircraft.

13. To expose the chassis completely, release the fastener on the rear of the dust cover and pull the cover from the chassis.

14. The incoming battery voltage switch can be remotely mounted in the most convenient location. When switching ON the regulator will automatically deliver 19 ± 1 volts to pins 13 to 20 of plug P1 and so to any equipment connected thereto. A simple test to check for current passing through is to actuate the LIGHT switch (S3) thus switching on the voltmeter lamp (LP1).

15. The calibrated scale of the voltmeter is marked in red over that part of the scale covered by the regulator (18-20 volts); this is to permit a quick reference at all times.

RESTRICTED

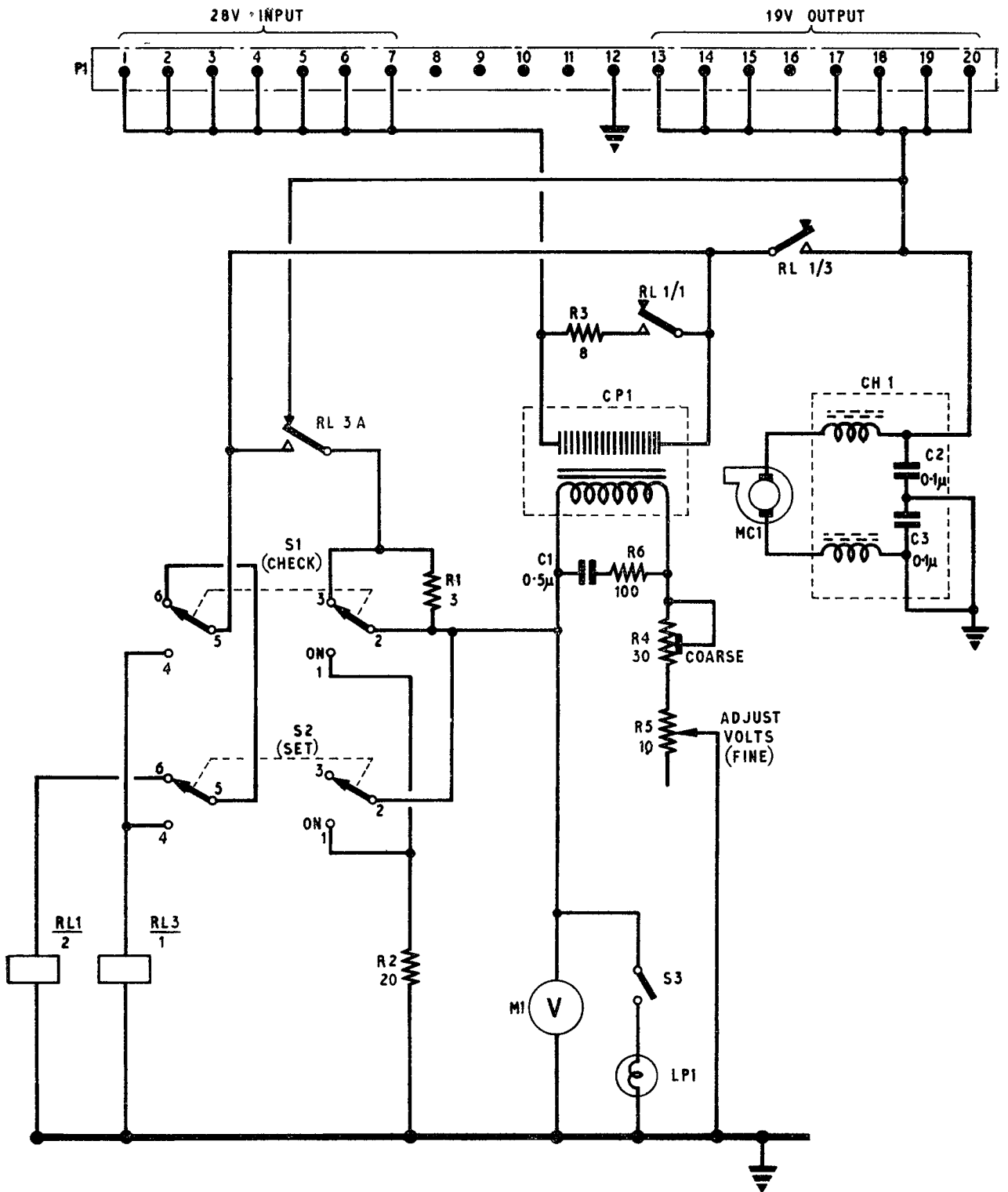

Fig. 3. Voltage regulator—circuit

16. Should the reading on M1 read out of calibration, operate the SET switch S2 and adjust ADJUST VOLTS R5 on the front panel until the meter registers 20 volts, this being the upper limit of the red calibration. Release SET, operate CHECK switch 3S1 and the meter should not register below 18 volts (the lower limit of the red calibration). Failure to reach this tolerance of ± 1 volt indicates that the voltage regulator is unserviceable.

17. The use of the various controls has already been described, the only part of the equipment that needs attention from time to time is the blower unit MG1 where a spot of anti-freeze grease should be applied to the bearings as necessary (*Vol. 4*). The brushes for the motor which drives the fan must be changed when they have become unduly worn (*Vol. 4*).

Chapter 9

AMPLIFYING UNIT TYPE 7435

(Speech Clipping Modulator fitted to Power and Radio Unit Type 4192)

LIST OF CONTENTS

	Para.		Para.
<i>Introduction</i>	1	"Speech clipping" circuit	39
<i>Power and radio unit</i>	4	<i>Low-pass filter</i>	46
<i>Construction</i>	6	<i>2nd audio amplifier</i>	47
<i>Interconnection in ARI.5874</i>	16	<i>Final modulator stage</i>	52
<i>Circuit description</i>		<i>Tone oscillator</i>	56
<i>Theory of speech clipping</i>	18	<i>Heater circuits</i>	61
<i>Audio frequency circuits</i>	27	<i>Relay function in audio circuits</i>	62
<i>Microphone amplifier</i>	29	<i>Power supplies circuit</i>	73
<i>1st audio amplifier</i>	31	<i>Rotary transformer</i>	76
<i>Voice operated gain adjusting circuit</i>	33	<i>Reduced power conditions</i>	85
		<i>"SAFE"</i>	86
		<i>"TUNE"</i>	90

LIST OF ILLUSTRATIONS

	Fig.		Fig.
<i>Front panel of modified power and radio unit Type 4192</i>	1	<i>Underside view of amplifying unit (1)</i>	5
<i>Speech waveform with and without "speech clipping"</i>	2	<i>Underside view of amplifying unit (2)</i>	6
<i>Block schematic of amplifying unit Type 7435</i>	3	<i>ARI.5874—Power and radio unit Type 4192 with speech clipping modulator—circuit</i>	7
<i>Amplifying unit sub-chassis</i>	4		

INTRODUCTION

1. The introduction of the speech clipping modulator (amplifying unit Type 7435—10U/16659) to the power and radio unit Type 4192 is brought about by Modification No. 2980 which, although retrospective will, at first, result in the power and radio units being fitted with either one of two types of amplifying unit. The alternatives are as follows:—

- (a) Amplifying unit Type 7435—10U/16659 (Speech clipping modulator).
- (b) Amplifying unit Type 4209—10U/16683 (Modulator without speech clipping).

2. A slight modification is made to the power and radio unit when the new amplifying unit Type 7435 is fitted. This involves the fitting of a new cover plate to the potentiometer access holes on the front panel. Since there is no change in the Type No. of a modified power and radio unit the presence of the new cover plate on the front panel will be the first indication that the power and radio unit incorporates the speech clipping modulator.

3. Amplifying unit Type 4209 is described in Chapter 5. The modified power and radio unit Type 4192 and the speech clipping modulator are described in the following paragraphs.

Power and radio unit

4. The power unit of the power and radio unit gives outputs of 300V and 600V HT; the former output is applied to the audio amplifier and both outputs to the transmitter circuits. Input power to the motor of the rotary transformer is from the aircraft 28V supply.

5. The signal input to the amplifying unit Type 7435 is from the intercommunications circuits of the equipment (microphone and key). A tone oscillator provides 1,000 c/s modulation on MCW and a parallel push-pull amplifier modulates the HT to the transmitter.

CONSTRUCTION

6. The complete power and radio unit consists of a main chassis to which is attached the front panel which consists almost entirely of an air intake dust filter (*fig. 1*). A removable dust cover fits over the whole chassis and is fixed at the rear of the unit by means of a quick release fastener. The dimensions of the unit are 8 × 10 in. (front panel) and chassis length 12½ in.

7. The whole base of the unit consists of a chassis 2½ inches deep and open on the underside. On the top surface of the chassis is mounted the rotary transformer (left) and the amplifying unit Type 7435 (right). The modulating transformer (T3) is mounted to the rear of the amplifying unit.

8. A special bracket covers the HT brushes at the rear of the rotary transformer; this carries the P.A. valves heater dropping resistor R41 and can be swung clear for access to the brushes.

9. The remainder of the chassis incorporates a motor start relay and components of the HT smoothing circuits.

10. Cooling air for the power and radio unit is drawn through the air filter box on the front panel (*fig. 1*) by a fan on the LT or front end of the rotary transformer.

RESTRICTED

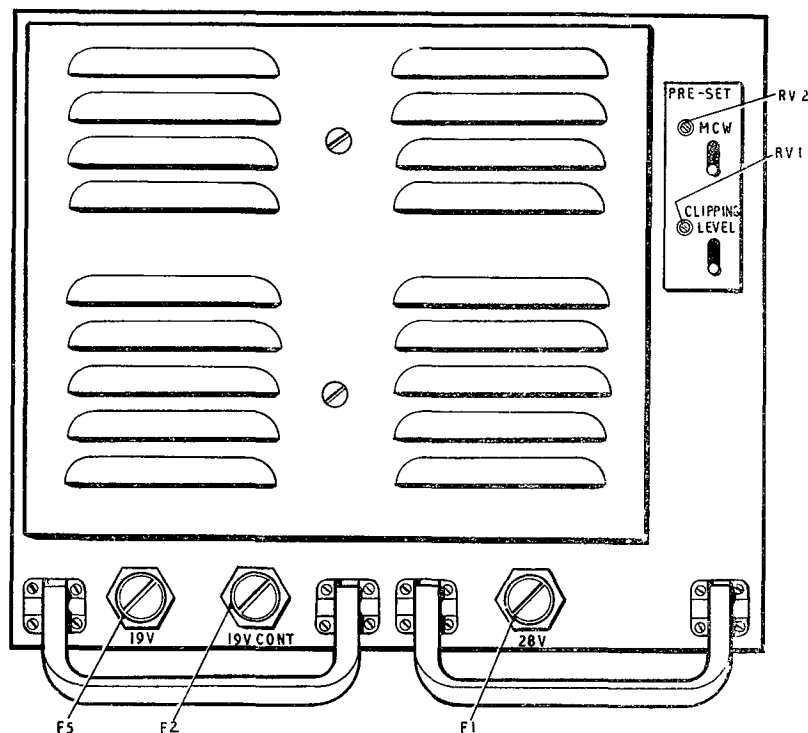

Fig. 1. Front panel of modified power and radio unit Type 4192

11. Some of the air intake is passed through the rotary transformer and some is taken directly from the fan through a slot in the cowl and directed across the output valves of the amplifying unit Type 7435 by a duct-deflector. The air exhaust is through louvres in the rear top of the dust cover.

12. Two quick release fasteners enable the dust cover over the two air filters to be removed and the air filters freed. A further four fasteners allow removal of the baffle plate behind the filters. This permits the fan cowl of the rotary transformer to be withdrawn for inspection of the LT brushes.

13. A sliding cover beside the air filter on the front panel provides access to two pre-set adjustments on the audio amplifier. These are:—

- (1) MCW gain adjusting potentiometer RV2 (Engraved MCW).
- (2) Speech clipping level potentiometer RV1 (Engraved CLIPPING LEVEL).

14. The rotary transformer is held in position by means of two clamp bands on a saddle. When these and the air duct are released and the electrical quick release connections freed, the rotary transformer can be removed.

15. The amplifying unit Type 7435 is fastened to the main chassis by means of four captive screws. Input connections are made by plug and socket (PL3, SK6—fig. 4). The output connections are made from the top caps of the output valves V9 to V12; plug PL4 connected to socket SK7 is not in use.

Interconnection in ARI.5874

16. The interconnection of the power and radio unit within the installation is made by plugs and sockets fixed to the rear face of the chassis. In common with other units of the installation these plugs and sockets (seven in all) plug directly into a back-plate at the rear of the power and radio unit-mounting assembly (Chap. 10).

17. The back-plate is interconnected to the remainder of the installation by means of connectors permanently wired to the back-plates of other units of the installation. Some details of the plugs and sockets at the rear of the power and radio unit are given below; a more complete account is given in Chap. 10.

PL1 20-way Power supply input plug

PL2 Coaxial 600V HT modulated output to transmitter plug

SK1 20-way Control and power supplies to transmitter socket

SK2 20-way socket Control and power supplies to control and drive unit.

SK3 4-way socket Transmitter interlock

SK3 4-way socket Receiver connections

SK5 8-way socket Connections to intercommunications equipment (sidetone, key, mic. circuit and 1/6 power circuit).

Note . . .

PL2 and SK3 are mounted on a bracket above the chassis

CIRCUIT DESCRIPTION

Theory of speech clipping

18. A normal speech waveform as illustrated in fig. 2, contains very high peaks produced by vowel sounds which do not add considerably to the intelligence contained in the waveform. In order not to over-modulate a transmitter with a waveform such as this, the gain of the modulator must be adjusted so that the peaks give 100 per cent. modulation.

19. This is achieved by adjusting the gain control of the modulating amplifier to give 100 per cent. modulation with a standard input, i.e. 10mV open circuit voltage from a 200-ohm source at 1,000 c/s, which represents the average output from the microphone.

20. It can be seen from fig. 2A that the average level of modulation under R/T conditions is approximately 30 per cent. The object of speech

RESTRICTED

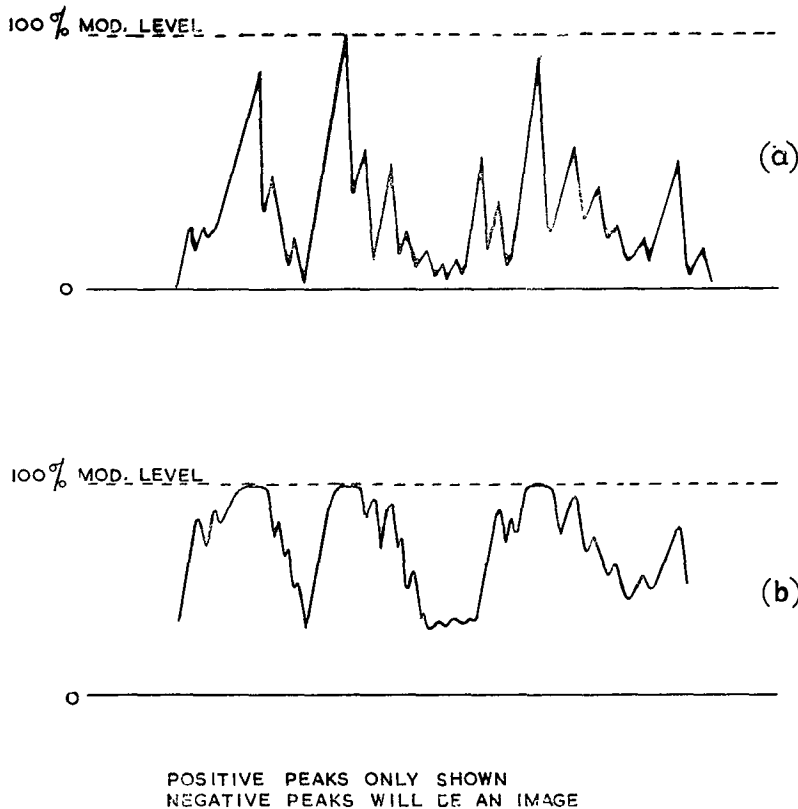

Fig. 2. Speech waveform with and without "speech clipping"

clipping is to raise the average level of modulation, thereby increasing the power output in the transmitted sidebands without over-modulation taking place.

21. Speech clipping in a modulating amplifier is achieved by increasing the gain of the amplifier and squaring off or "clipping" the peaks of the input waveform as shown in fig. 2b. Diodes are used to square or "clip" both positive and negative peaks and are so biased that they operate at a signal level which gives 100 per cent. modulation.

22. The limiting factor to the amount of extra gain available in the modulating amplifier is the amount of distortion of the waveform which can be tolerated, although up to a point the intelligibility is increased owing to the raising of the consonant levels.

23. The optimum gain figure is 15dB, so that 100 per cent. modulation will be obtained with an input of -15dB on the original 10mV input, that is 2.7 mV and all inputs up to 10mV will not therefore exceed 100 per cent. modulation.

24. The effect of distorting the input signal to something approaching a square-wave produces predominantly third order harmonics which are transmitted in the form of very wide sidebands. This is overcome by introducing a low pass filter to follow the clipping stage which offers a high impedance to all frequencies above 4,000 c/s, a

figure which represents the normal bandwidth required for intelligible speech transmission.

25. The voice operated gain adjustment device (V.O.G.A.D.) is included in the modulating amplifier to prevent overloading of the first stage when input levels in excess of 10mV are applied (such as shouting into the microphone).

26. A portion of the signal is again applied to a diode biased so that it will conduct on input levels above the order of the 10mV, the voltage appearing across the diode load is applied as negative bias to the first stage.

Audio frequency circuits

27. The audio frequency circuits consist of (1) the amplifying unit Type 7435, which includes an audio amplifier and modulating unit and (2) the modulating transformer T3.

28. A block diagram is given in fig. 3 and a complete circuit diagram of the power and radio unit is given in fig. 7, the audio frequency circuits are shown at the left of the diagram. Illustrations

of the amplifying unit Type 7435 are given in fig. 4, 5 and 6.

Microphone amplifier

29. The balanced microphone input enters the power and radio unit at pins 3 and 4 of SK5 and is taken through screened leads via socket SK6 and plug PL3 (pins 1 and 2) to the primary winding of the transformer T1. The secondary winding of T1 is connected to the input stage V1 and V2 operating in push-pull.

30. The anode supply to these valves is switched by the relay contacts RL4A and HT is applied in the R/T conditions only. HT is from the 300V KEY terminal 17 on the 28-way socket SK1 via pin 11 on SK6 and PL3. The screen connections to the valves is from the 300V supply via the potential divider R4/R5. These valves (CV2135) act as the microphone amplifier and also as the controlled stage in the voice operated gain adjusting device. (V.O.G.A.D.).

1st audio amplifier

31. With zero input signal the valves V1 and V2 are biased by the cathode resistor R69. The anodes of the valves are coupled by C17, R62 and C18, R63 to the grids of the push-pull double-triode V3; this is the 1st audio amplifier stage using a CV455.

32. Cathode-bias to the two triodes is provided by the resistor R9. The output from the anode loads

RESTRICTED

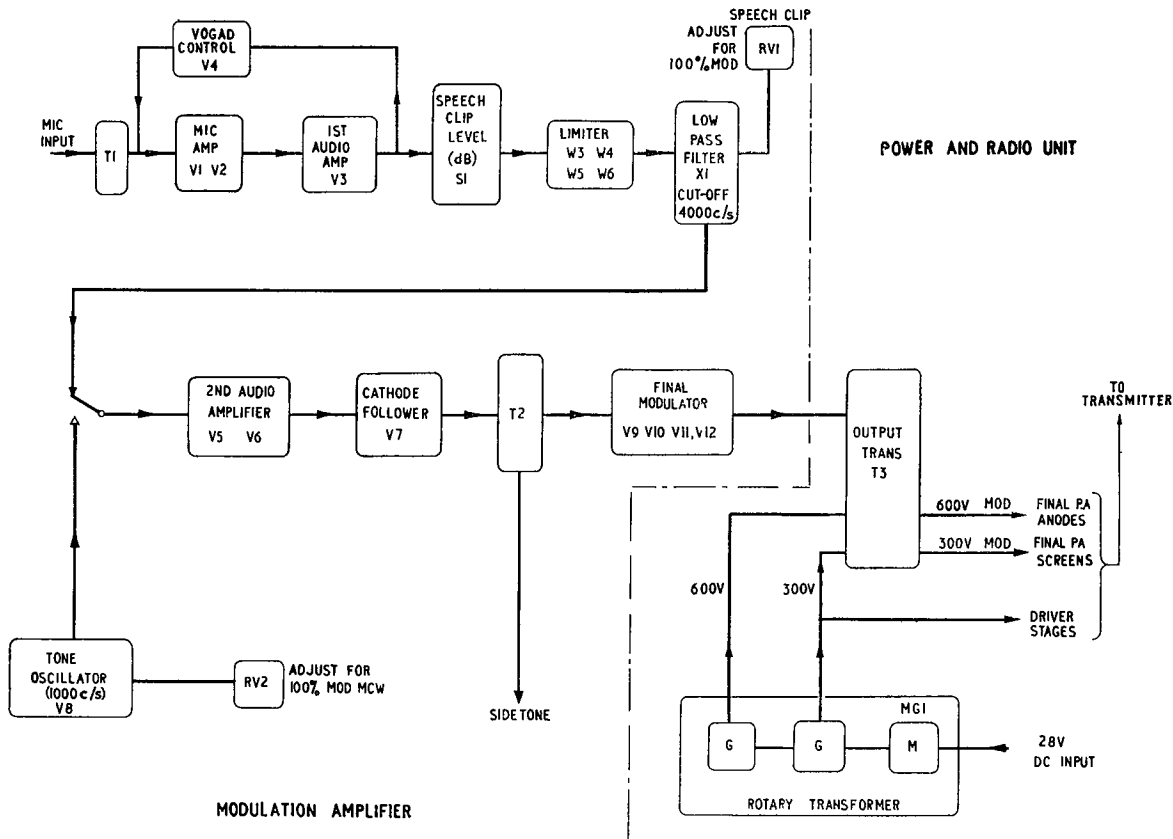

Fig. 3. Block schematic of amplifying unit Type 7435

R10 and R11 of V3a and V3b is coupled via C3 and C4, respectively, to the cathodes of V4a and V4b. This is a double-diode rectifier CV140 (V4) employed as the control source for the V.O.G.A.D.

Voice operated gain adjusting circuit

33. The double-diode V4a and V4b acts as a normal push-pull rectifier coupled by C3 and C4, the load being R1 and R2 in the input of the microphone amplifier stage.

34. A delay bias from the network R16, R24 and RV1 is applied from the 300V line at plug PL3 pin 12 from the source at socket SK1 pin 25. The delayed bias is applied to the cathodes of V4a and V4b so that when an audio level greater than this delay is applied, the negative potential from the anodes is applied to the junction of the resistors R1 and R2.

35. The V.O.G.A.D. action on the gain of the microphone amplifiers V1 and V2 is effected by two related circuits. The rectified negative potential at the junction of the resistors R1 and R2 is applied to the grids of V1 and V2; at the same time a current dependent on this potential will flow from earth through the selenium rectifiers W1 and W2.

36. As the magnitude of the current is increased, the selenium

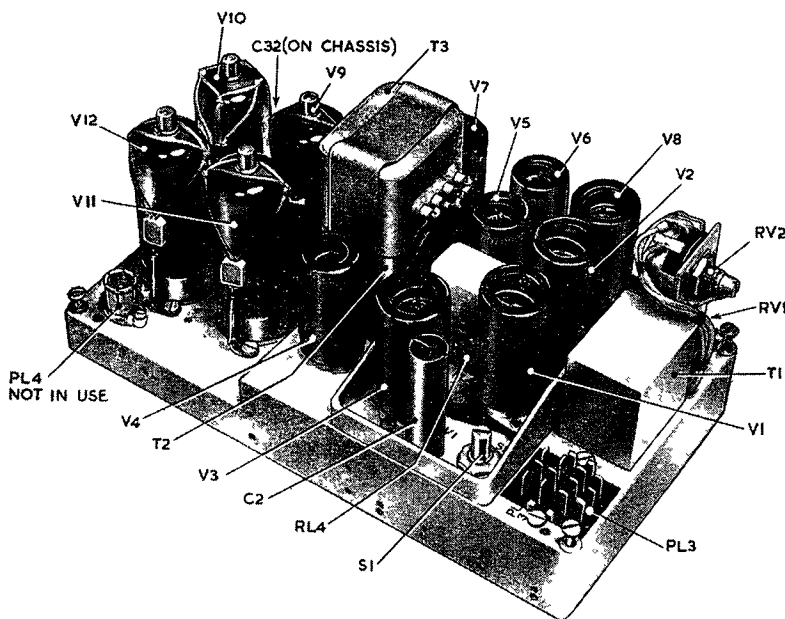

Fig. 4. Amplifying unit sub-chassis

RESTRICTED

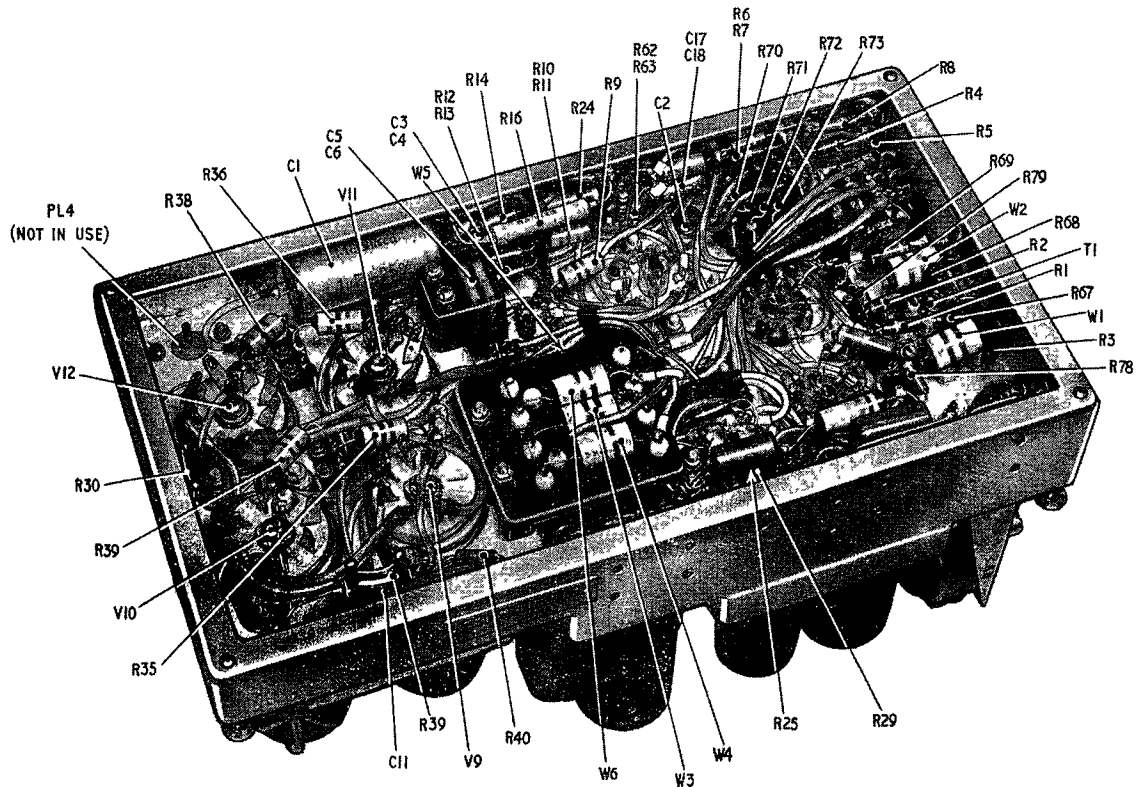

Fig. 5. Underside view of amplifying unit (I)

rectifiers in series across the secondary of the transformer T1 will behave as a decreasing load resistor and thus reduces the audio signal voltage on the rids of V1 and V2.

37. The potential developed across resistor R3 will also increase the negative grid bias and the combination of the two effects will provide a relatively constant audio level on the cathodes of V4a and V4b.

38. Attenuation of the controlled signal is available in six steps by a balanced network formed by R12 and one of the five resistors R80, R70, R71, R72 and R73 together with R13 and one of the five resistors R81, R74, R75, R76 and R77. These resistors are selected by the switch S1 as shown in fig. 7.

"Speech clipping" circuit

39. The selected audio level is coupled by the capacitors C5 and C6 to a push-pull series limiter which provides "speech clipping". This in effect "squares off" the tops of the modulation to enable a higher average level of modulation to be achieved with the resulting improved intelligibility under weak signal conditions, particularly in the presence of noise.

40. The limiter consists of the selenium rectifiers W3, W4 and W5, W6 together with the resistors

R17, R19, R21 and R18, R20, R22, respectively. The rectifiers are biased positively through the junction of R19, R20 from the potential divider RV1 off the 300V supply.

41. Consider one half of the limiter circuit and assume that the bias from RV1 is E volts and that W3 and W4 behave as "perfect" diodes. Assume that the value of R19 is R ohms, R17 is R/2 ohms and R21 is R ohms.

42. With these assumed values and with a current flowing through W3 and W4, the voltage across R17 and R21 will be E/4 volts. approx.

43. Under operating conditions the incoming audio signal voltages across C5 will be superimposed on this value of E/4 volts. When the positive swing of the incoming signal takes the potential across R17 above E/2 volts the rectifier W3 ceases to conduct thus leaving a potential of E/2 across R21.

44. On the negative swing, W3 conducts continuously and the potential appears across R21. If, however, the negative swing falls below zero, W4 ceases to conduct and the potential across R21 cannot fall below zero. Thus no matter what the input to the limiter, the potential across R21 is limited to E/2 volts on positive swings and zero on the negative.

RESTRICTED

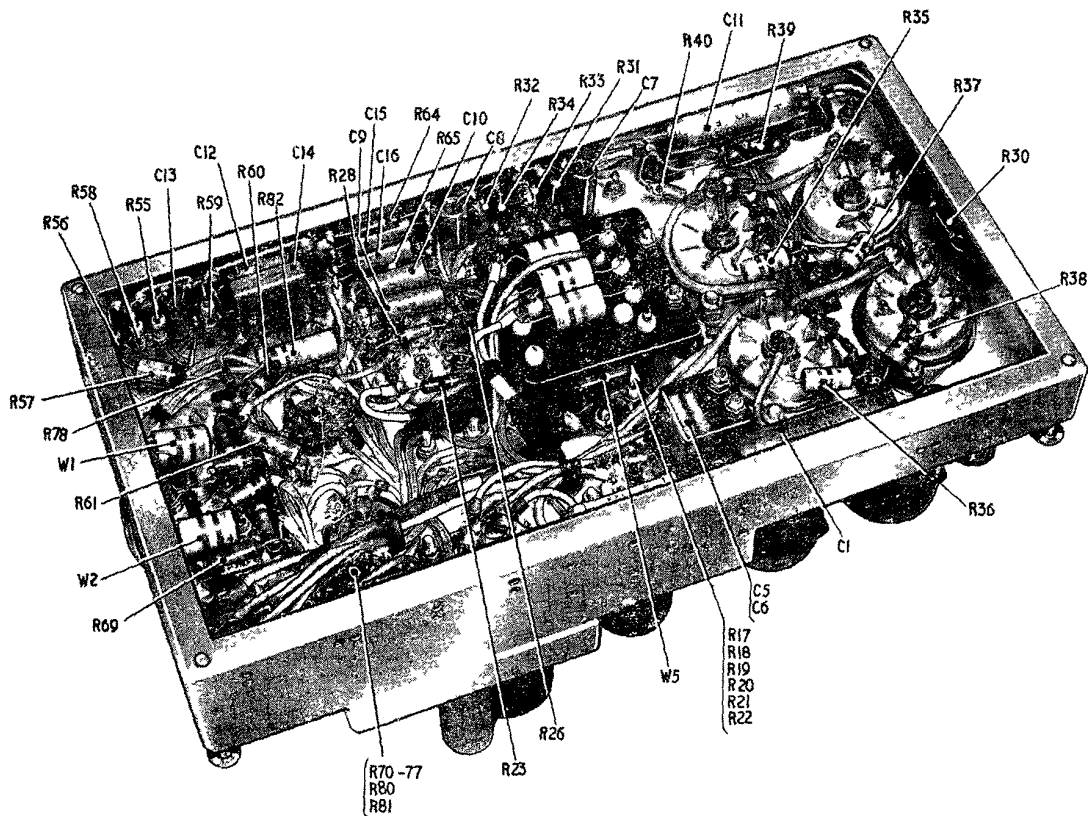

Fig. 6. Underside view of amplifying unit (2)

45. The potentiometer RV1 is used to adjust this value of $E/2$ volts to correspond to approximately 100 per cent modulation. The selector switch S1 then allows, by control of the input, a choice of amount of clipping as follows; 3, 8, 11, 14, 16 or 19bD nominally.

Low-pass filter

46. The clipped audio signal is then coupled to the 2nd audio amplifier via a low-pass filter X1 which is designed to cut off at 4,000 c/s.

2nd audio amplifier

47. The second audio amplifier consists of two CV136 valves connected in push-pull (V5 and V6). The anode and screen supplies are from the 300V line at pin 25 of SK1. The screen voltage is dropped by the resistor R25.

48. Across the anodes of V5 and V6 is connected a phase correction network R26, R28, C9, R27, R29 and C10 which partly compensates for distortion that occurs in the output transformer T3.

49. The anodes of V5 and V6 are resistance-capacitance coupled by C7, R31, and C8, R32 to the grids of the push-pull cathode-follower drive stage V7 (CV491—V7a and V7b), the anodes of which are connected to the 300V line through R30.

50. The cathode load of this stage is provided by the iron cored choke formed by the primary of T2; the voltages across this are applied to the grids of the final modulator stage.

51. A secondary winding on the transformer T2 provides sidetone to pin 10 of PL3/SK6 which is then connected via the relay contact 2A to either the receiver telephones SK4/1 or the intercom telephone (SK5/1).

Final modulator stage

52. The final modulator stage employs four tetrode valves (CV428) connected in parallel push-pull and working in Class AB. The bias is obtained partly from the cathode resistor R39 decoupled by C11, but the main part of the bias is from the positive 28V supply at SK2 pin 3 via PL3 pin 8 or 9 and relay contacts 4B, 2B, 1B and 3A.

53. When the 28V bias is removed by the relay contacts the resistor R40 behaves as an extra cathode-bias resistor and biases the stage to cut-off. The capacitor C19 across R40 limits the transients appearing across the output valves when relay contact 4B opens.

54. The anodes of the four tetrodes are joined to the primary of the output transformer T3, the anode supply being obtained at the centre tap

RESTRICTED

from the 600V supply at PL2 (600V +MOD). The transformer is not a part of the amplifying unit sub-chassis but is mounted at the rear of the main power and radio unit chassis.

55. There are two secondary windings to the transformer. The winding marked 5-6 is the main secondary supplying the 600V modulated supply to the transmitter unit power amplifier valves via PL2 (*Chap. 4*). Winding 7-8 provides the 300V modulated supply to the transmitter power amplifier valve screen grids via SK1 pin 22 (300V MOD).

Tone oscillator

56. The tone oscillator circuit employs a double-triode CV455. The triode V8a is used as a type of phase shift oscillator operating at approximately 1,000 c/s. It is a cathode-follower with a "twin Tee" network consisting of C12, R59, C14 and R55, C13, R58.

57. The cathode-follower has a gain of slightly less than unity, but since the network to which it is connected has a corresponding gain of slightly greater than unity, oscillation will take place.

58. A proportion of the output from the relatively high cathode load (potentiometer RV2) is directly coupled by means of the slider of RV2 to the second triode V8b. This is a conventional phase-splitter stage and gives a symmetrical output across its anode and cathode.

59. This output is taken through C15, R64 and C16, R65 to the grids of the second audio amplifier stage V5 and V6. The coupling is of a relatively high impedance and has no effect on the operation of the speech clipping circuit.

60. The potentiometer RV2 is used as a MCW level control of modulation.

Heater circuits

61. All the valves on the amplifying unit chassis are connected in series-parallel to the 19V stabilized supply via PL3/SK6 pin 4, fuse F2 and pin 14 of SK2 on the main power and radio unit chassis.

Relay function in audio circuits

62. The following paragraphs describe the function of the relays in the audio amplifier with relation to the selected position of the services switch on the remote control unit.

CW

63. During operation on CW an earth is applied to the connection at pin 13 of SK2 (MCW/CW); relay RL4/2 is energized from the 28V supply at pin 11 of SK1.

64. The 300V HT supply from pin 11 of PL3 (the keyed supply from pin 17 of SK1—"300 KEY") is connected via relay contact 4A to the anode of the tone oscillator triode V8a which will thus be in operation. (The anode of V8b is connected to the 300V supply at pin 25 of SK1.)

65. Relay contact 4A also disconnects the HT supply from the anodes of V1, V2 and V3, thus disabling the speech input stages. Relay contact 4B closes to connect the cathodes of the modulator valves (V9 to V12) through pin 8 of PL3/SK6 and the closed relay contact 1B to relay contact 3A which, however, remains open. The modulator valves then remain cut-off by the resistor R40.

66. When the key is "made" relay RL2/2 is energized and the tone signal from V8 is passed from V5 and V6 to V7 where the sidetone is routed from transformer T2 via pin 10 of PL3/SK6 and relay contact 2A to TEL+ at pin 1 of SK5. The closing of contact 2B is ineffective in the conditions obtaining.

MCW

67. With MCW facilities pins 4 and 13 of socket SK2 (MCW/R/T and MCW/CW) are earthed, thus energizing relays RL3/2 and RL4/2. Relay contact 3A closes and connects the modulator cathodes to the positive 28V supply at pin 3 of SK2 (relay contact 4B closed) thus allowing the modulator stage to operate. Relay contact 2B is inoperative since the modulator stage is not keyed on MCW; it is therefore shorted by contact 4B.

68. MCW is provided at 100 per cent. modulation with no clipping. Sidetone is again provided at pin 1 of SK5 as before.

R/T

69. For R/T operation pin 4 of SK2 (MCW/R/T) only is earthed and relay RL3/2 is energized. Relay contact 4A now disconnects the tone oscillator and connects the 300V HT to the anodes of the speech input valves V1, V2 and V3.

70. With relay contact 4B released, the cathodes of the modulator stage are now connected through pin 9 of PL3, relay contacts 2B, 1B and 3A to the positive 28V supply. The connection depends upon the closing of relay contact 2B which will only close when the key circuit is closed and relay RL2/2 thus energized.

71. Speech modulation is possible with the conditions described above and sidetone is taken from transformer T2 as before. When the key circuit is opened relay contact 2B is released and R40 cuts off the modulator valves as an economy measure. This also occurs when the TUNE relay RL1/2 is operated under TUNE conditions.

INT

72. When the equipment is being set up in the INTERTUNE condition, relay RL1/2 is energized from either contact pin 10 of SK1 or pin 10 of SK2. Contact 1B opens and effectively puts the modulator in the CW condition.

Power supplies circuit

73. The input power supplies to the whole of the transmitter equipment is applied via PL1; with 28V positive on pins 13-20, 19V positive stabilized on pins 11 and 12 and the common earth on pins 1-10.

RESTRICTED

74. When the equipment is switched to **STANDBY** the relay RL6/1 is energized from the 19V supply and closes contact 6A thus connecting the 28V supply through the 3-amp fuse F1 to a section of the control circuits. Contact 6A also completes the circuit of the energizing coil of RL7/1 which closes contact 7A and connects the 19V positive lines to another section of the control circuits and to the valve heater circuit of the equipment.

75. The following fuses are mounted on the front panel of the equipment:—

- (1) Fuse F1, 3-amp. Protects the 28V control circuits.
- (2) Fuse F2, 2-amp. Protects the 19V control circuits and the valve heaters in control unit Type 4190 or Type 4243.
- (3) Fuse F5, 10-amp. Protects all the 19V supplies.

Rotary transformer

76. The rotary transformer is intended to operate at a nominal input of 28V as normally provided by the aircraft battery supplies. There are two secondary windings giving 300V and 600V HT respectively. These outputs supply 300V and 600V HT to the incorporated amplifying unit Type 7435, and 300V HT to the crystal-controlled oscillator in the control unit Type 4190; the 300V supply (modulated and unmodulated), and the 600V supply (modulated) is applied to the transmitter unit.

77. In the **HT ON** or **TX** condition of the equipment, relays RL8/1 and RL9/2 are energized from pin 2 of SK3. Contact 8A makes and connects the 28V supply from PL1 to the motor side of MG1 through the low value resistors R44 and R45. At rest, the armature approximates to a short-circuit, and most of the volts are dropped across R44 and R45 so that RL10/1 cannot operate. Relay RL12/1 is also energized from the 28V supply.

78. As the speed of the motor and the armature resistance increases, the back EMF builds up to approximately 20–24 volts and relay RL10/1 is energized through the closed contacts 9A. Relay contact 10A closes and short-circuits the starting resistors R44 and R45, thus allowing the motor to reach its maximum speed.

79. The relay contact 9B breaks the circuit between pins 3 and 4 of SK3 and can be used to interlock with the circuit of any other equipment in the aircraft which may be connected to SK3. When SK3 is not connected to other equipment pin 1 and 2 are shorted by a special link which is plugged into the back-plate.

80. After transmission the relays RL8/1 and RL9/2 are de-energized and the motor-generator switched off. Contact 9A breaks the circuit of RL10/1 and contact 10A reinserts the starting resistors in the motor circuit ready for any immediate restart.

81. The negative side of the motor winding is earthed via PL1. Noise suppression on the positive side is provided by the two-stage filter L6, C25 and L7, C26 mounted in a screened box.

82. Outputs from the generator side of the machine are provided by two armature windings giving, respectively, 300V HT and 600V HT. The 300V output is connected through the noise filter L5, C28 and L4, C27 and then through L8, C22 connected as a one-stage ripple filter.

83. The 600V output from the machine is taken through the noise filters L3, C30 and L2, C29 to the secondary winding of transformer T3 and C24 which gives some ripple suppression.

84. Fuses F3, 750mA and F4, 250mA, protect the HT circuits and the "noise" filters. They are mounted inside the unit to avoid bringing unfiltered leads and dangerous voltages to the front panel of the equipment. Spare fuses for F3 and F4 are mounted under the chassis.

Reduced power conditions

85. The resistor R43 in the 300V line to the secondary winding of transformer is brought into circuit by the breaking of relay contact 11A. Relay RL11/2 is energized when the equipment is in the **SAFE** condition (from pin 19 of SK2) and R43 limits the screen potential of the transmitter P.A. stage.

"SAFE"

86. The **SAFE** condition is provided primarily to reduce the output power of the transmitter to a safe level to prevent corona discharge which occurs at altitude in the event of a pressure leak in the suppressed aerial tuning unit (*Sect. 2*).

87. This low power facility is also provided under control of the operator in the form of a **HIGH/LOW** power switch connected between pin 6 of SK5 and earth on the "Intercom" output socket. (*Chap. 10—fig. 8*.)

88. "Safe" conditions occur when the **LOW OUTPUT** line is earthed by the **LOW POWER** switch or by the barometric pressure switch in the suppressed aerial tuning unit (*para. 86*). An immediate reduction in power is obtained since the screen potential of the transmitter P.A. stage is reduced by the potential divider formed by R43 and R51, the latter being taken to earth via pin 20 of SK2 and the control unit Type 4190 at 1RL7B (*Chap. 3*).

89. In addition to the reduced power obtained at the P.A. stage, relay contact 11B opens and inserts an extra cathode bias resistor R50 in the audio output stage V5–V8.

"TUNE"

90. When the **TEST TUNE KEY** on the control and drive unit or the suppressed aerial selector unit is in the **TUNE** position, the resistor R51 is removed from its earth connection by 1RL7B in the control and drive unit (via pin 20 of SK2— *fig. 7*). Tuning can then take place at nearly full power since only R43 remains to limit the screen voltage.

RESTRICTED

Chapter 10

RACKING SYSTEM, BACK-PLATES AND INSTALLATION DETAILS

LIST OF CONTENTS

	Para.		Para.
<i>Racking system and back-plates</i>		<i>Connectors</i>	20
<i>Introduction</i>	1	<i>Equipment wires specification</i>	22
<i>Racking system</i>	4	<i>Method of fitting back-plates with the aid of jigs</i>	23
<i>Back-plates</i>	9		
		LIST OF TABLES	
<i>Installation and cabling</i>		<i>Back-plate jigs</i>	1
<i>ARI. 5874</i>	15	<i>Connector and unit back-plate coding</i>	2
<i>Installation of transmitter, receiver and ancillary equipment</i> 16		<i>Fixed equipment</i>	3
		<i>Removable equipment</i>	4
		<i>Connector schedule</i>	5

LIST OF ILLUSTRATIONS

	Fig.
<i>Power and radio unit with back-plate</i>	1
<i>Back-plate and connections to power and radio unit</i>	2
<i>Back-plate and connections to transmitter</i>	3
<i>Back-plate and connections to receiver</i>	4
<i>Back-plate and connections to control unit Type 4190 or 4243</i> 5	5
<i>Back-plate and connections to voltage regulator</i>	6
<i>Fitting back-plate with the aid of jig</i>	7
<i>ARI.5874 arranged for suppressed aerial system</i>	8

RACKING SYSTEM AND BACK-PLATES

Introduction

1. This chapter describes the racking system and back-plates for the following items :—

- (1) Power and radio unit Type 4192
- (2) Transmitter Type T.4188
- (3) Receiver Type R.4187
- (4) Control unit Type 4190
- (5) Control unit Type 4243 (*Sect. 3*)
- (6) Voltage regulator (5UC/6010)

2. Information on the back-plates of units belonging to suppressed and fixed wire aerial systems is given in *Sect. 2* and *Sect. 3* respectively. This is with the exception of the back-plate for control unit Type 4243 (*Sect. 3*) which is identical to that of the control unit Type 4190 and is therefore described in this chapter (*para. 14*).

3. The control unit (remote) Type 4189 may be either panel mounted or console mounted; the junction box Type 4191 is panel mounted. Neither of these units are fitted on anti-vibration mountings.

Racking system

4. The construction of the racking system will normally be carried out by the aircraft constructor. The racking conforms with that described in the British Standards Institution publication "Sizes and Forms of Civil Aircraft Radio Equipment".

5. The racking consists of horizontal U-shaped channel members on which are mounted a number of left and right side members. The latter are cut to suit the lengths of individual units and positioned on the horizontal members to the width required to accept the unit.

6. Each set of left and right side members when mounted on the horizontal members forms a mounting tray for the particular unit. The "rear" ends of the side members are turned in for fitment of the back-plate carrying the plugs and sockets which mate with associated sockets and plugs on the rear panel of the individual units (*para. 14*).

7. As many units, or multiples of a complement of units, as may be required can be mounted on the racking system. In some aircraft the horizontal members will be mounted in tiers (generally two) one above the other to form a rectangular rack.

8. The completed racking is mounted on anti-vibration mountings based on a rack loading of 2.5 lb. per inch run. It may be necessary to fit additional anti-vibration mountings to those at the ends of the rack when several heavy units are mounted on the same rack.

Back-plates

9. Interconnection between the individual units of an installation is made by engaging the plugs and sockets on the rear panel of the units with the respective sockets and plugs on the ends of the cables located in the back-plates on the racking system.

10. The back-plates are positioned on the mounting with the aid of special jigs detailed below. If the back-plates are fitted without the use of jigs, serious misalignment will probably occur with resultant damage to the plugs and sockets of the equipment and the back-plates. The method of fitting a back-plate with the aid of a jig is described in *para. 23*.

TABLE 1
Back-plate jigs

The following jigs *must* be used when assembling back-plates on the racking system

A.M. Stores ref.	Back-plate	Unit
10AG/51	Jig, locating (back-plate 10AR/438)	For power and radio unit Type 4192
10AG/52	Jig, locating (back-plate 10AR/440)	For transmitter Type T.4188
10AG/53	Jig, locating (back-plate 10AR/441)	For control unit Type 4190 (or 4243)
10AG/54	Jig, locating (back-plate 10AR/442)	For receiver Type R.4187
10AG/55	Jig, locating (back-plate 5UC/6011)	For voltage regulator 5UC/6010

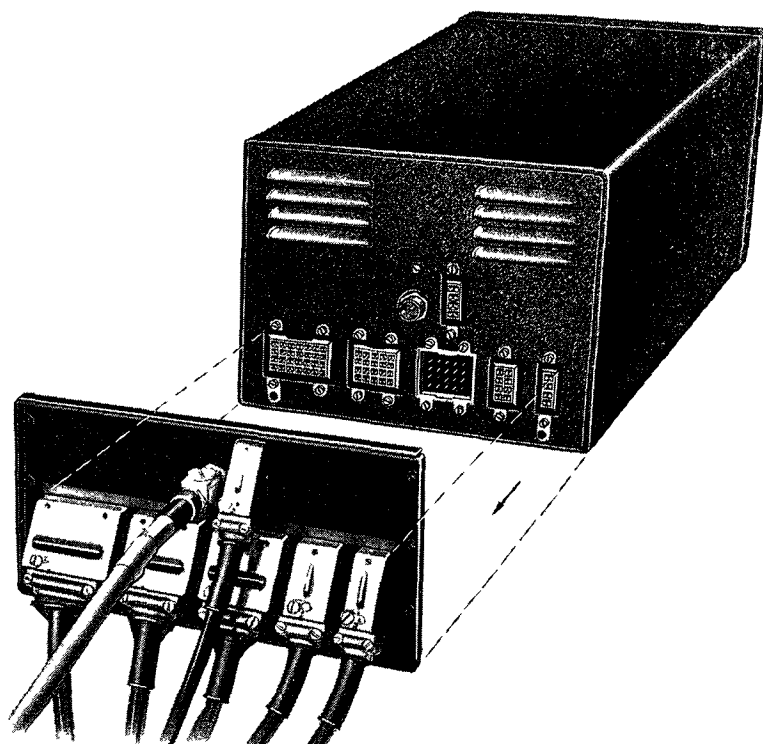

Fig. 1. Power and radio unit with back-plate

TABLE 2
Connector and unit back-plate coding

Unit	Code letter
Control unit Type 4190	1
<i>or</i>	
Control unit Type 4243	1
Transmitter Type T.4188	2
Power and radio unit Type 4192	3
Receiver Type R.4187	4
Control unit (remote) Type 4189	11
Junction box Type 4191	12
Voltage regulator	

Connector Code	Terminations
A	1A—Control unit Type 4190
B	1B—Control unit Type 4190
C	1C—Control unit Type 4190
D	2D—Transmitter
E	2E—Transmitter
F	3F—Power and radio unit
G	—
H	—
	3A—Power and radio unit
	2B—Transmitter
	2C—Transmitter
	3D—Power and radio unit
	3E—Power and radio unit
	— Intercom equipment
	—
	—

RESTRICTED

Table 2 (Continued)

Connector and unit back-plate coding

Connector Code	Terminations
J	3J Power and radio unit External transmitter interlock or transmitter Type T.4188 shorting plug
K	—
L	1L Control unit Type 4190
M	4M Receiver —Power supplies
N	3N Power and radio unit
P	3P Power and radio unit —Power supplies
AD	4AD Receiver
AE	1AE Control unit Type 4190
AF	1AF Control unit Type 4190
AG	1AG Control unit Type 4190
AH	11AH Control unit (remote) Type 4189
	4L Receiver 12AD Junction box 12AE Junction box —Aerial equipment —Aerial equipment 12AH Junction box

11. Each back-plate carries two locating spigots which align the individual units to the associated back-plate. To improve mating, the multi-pole plugs and sockets will tolerate a *small* amount of misalignment. The coaxial sockets on the back-plates are designed to "float" for the same reason.

12. An illustration of the back-plate for the power and radio unit Type 4192 is shown in fig. 1. The upper part of the illustration shows the plugs and sockets on the rear panel of the power and radio unit.

13. Each of the plugs and sockets on the rear panel are numbered in accordance with the circuit references, but the numbering of the plugs and sockets on the back-plates is related to the particular connector which it terminates, e.g., the socket SK1 on the rear panel will connect with the 28-pole plug 3D on the back-plate (*fig. 2*); the plug is one termination of the 28-core connector D, the other end being connected to the transmitter back-plate at socket 2D (*fig. 3*). The numbering of the back-plates of the individual units and the associated cables is given in Table 2.

14. No further description of the back-plates is necessary but each one is illustrated with the rear panel of the associated unit as follows :—

- Back-plate for power and radio unit fig. 2
- Back-plate for transmitter fig. 3
- Back-plate for receiver fig. 4
- Back-plate for control unit Type 4190 (or 4243) fig. 5
- Back-plate for voltage regulator fig. 6

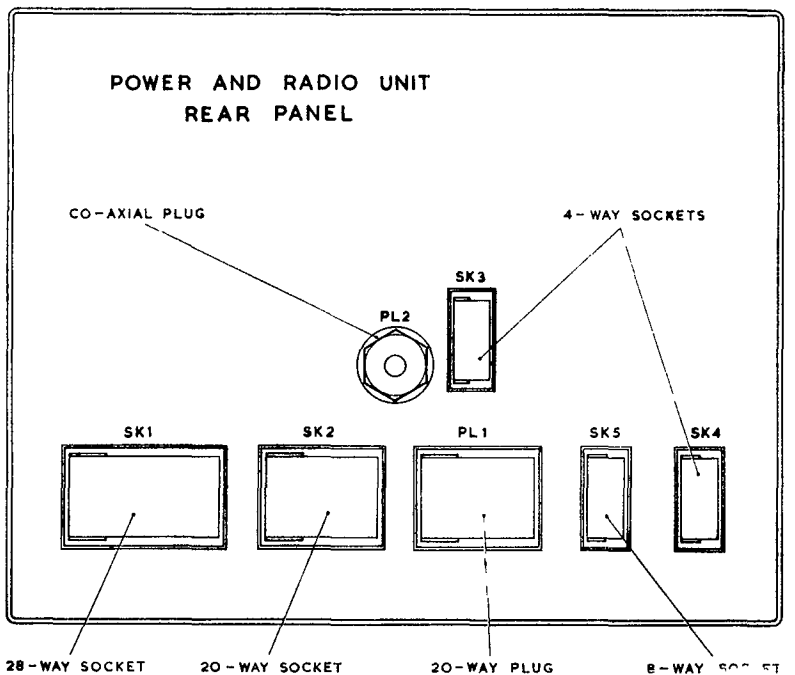
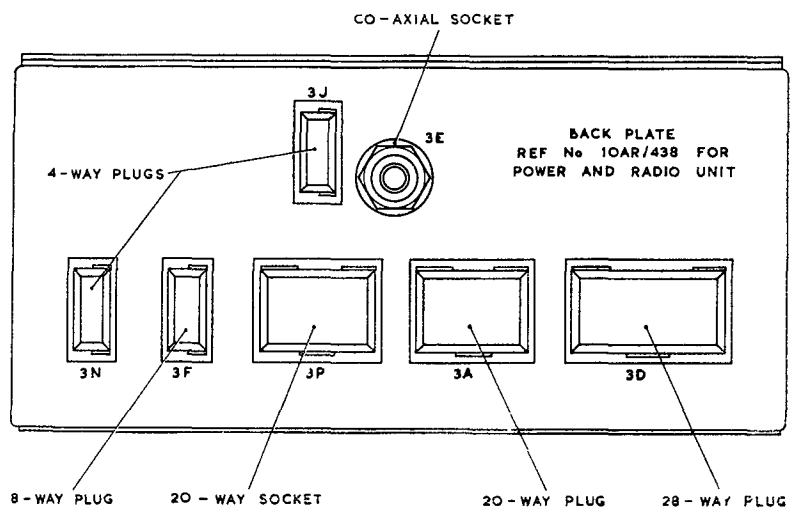

Fig. 2. Back-plate and connections to power and radio unit

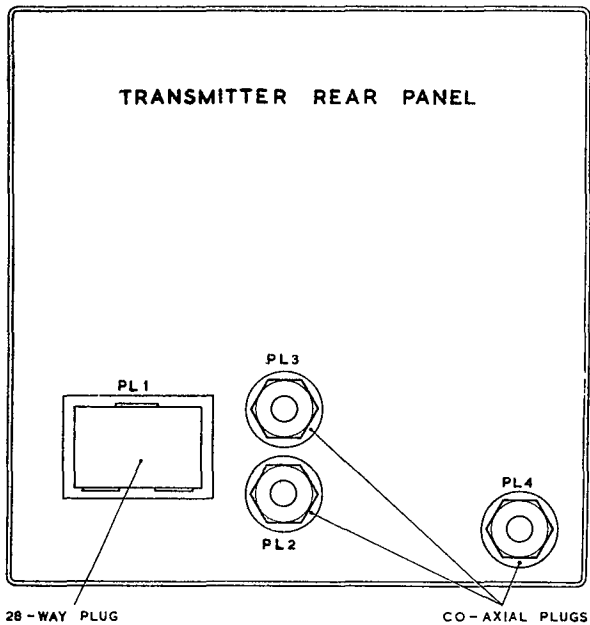
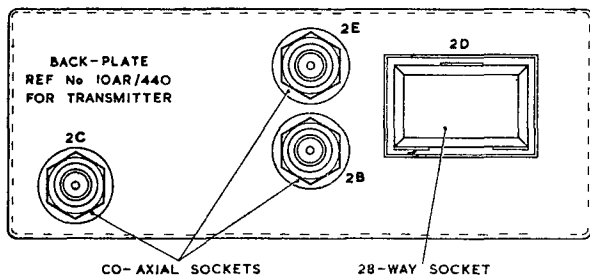

Fig. 3. Back-plate and connections to transmitter

installation and does not include the aerial system. For information on a complete suppressed aerial installation reference should be made to Sect. 2; fixed wire aerial installations are described in Sect. 3. For wiring to the aircraft power supplies, consult the relevant Aircraft Handbook.

18. The interconnections of the installation are shown connected to the back-plates with the exception of the control unit (remote) Type 4189 and the junction box Type 4191 which have direct entry plugs and sockets.

19. The items in Table 4 are listed as removable and include the main units of the installation.

Connectors

20. The schedule of connectors in Table 5 is provisional and includes those of the suppressed aerial system. A.M. Type and reference numbers for connector sets in various types of aircraft will be issued later.

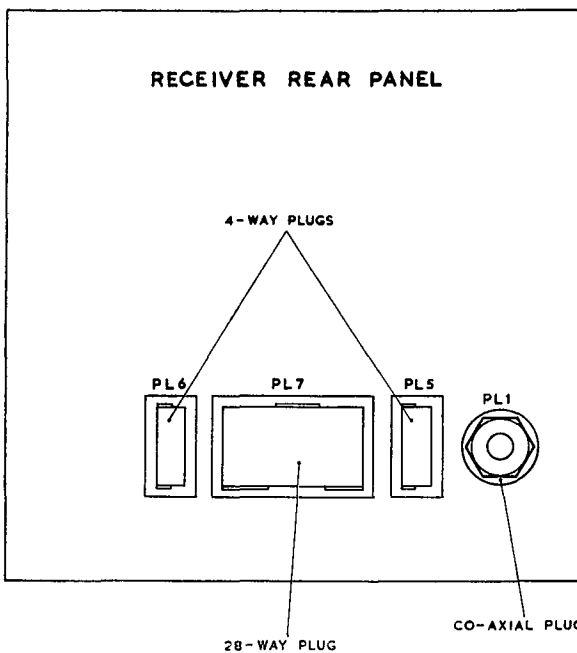
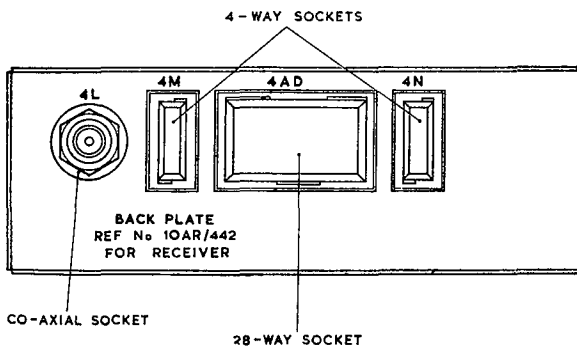

Fig. 4. Back-plate and connections to receiver

INSTALLATION AND CABLING

ARI.5874

15. As stated in earlier chapters there are three variant installations in the one designation ARI. 5874, the complement of movable equipment and cabling being different in each case. In the following description information is given on the main items of equipment and ancillaries to the exclusion of the aerial equipment which is described in Sect. 2 and Sect. 3.

Installation of transmitter, receiver and ancillary equipment

16. The items in Table 3 are listed as the fixed equipment required for the installation of the transmitter, receiver and ancillary equipment. The items are normally supplied to the aircraft contractor for installation at the works.

17. An illustration of the interconnections of the transmitter, receiver and ancillary equipment is shown in fig. 7. In itself this is not a complete

TABLE 3
Fixed equipment

A.M. Stores Ref.	Description	Service	Dimensions (approx.)	
			Width	Height
10AR/438	Back-Plate	For power and radio unit	10	× 5 in.
10AR/440	„	For Transmitter T.4188	7 $\frac{1}{4}$	× 3 in.
10AR/441	„	For control unit Type 4190 or Type 4243 (Sect. 3)	7 $\frac{1}{4}$	× 7 in.
10AR/442	„	For receiver R.4187	7 $\frac{3}{4}$	× 3 in.
5UC/6011	„	For voltage regulator (5UC/6010)	3 $\frac{3}{4}$	× 5 in.

TABLE 4
Removable equipment

A.M. Stores Ref.	Description	Service	Approx. weight (lb.)
5UC/6010	Voltage regulator	Stabilized 19V supply to equipment	10.75
10L/16204	Control unit (remote) Type 4189	Remote control of transmitter/receiver and aerial equipment	2.65
10D/19066	Junction box Type 4191	Junction box between remote control unit and transmitter/receiver	1.4
10L/16205	Control unit Type 4190	Control and drive of transmitter. For use with suppressed aerial system	13.6
10L/16207	Control unit Type 4243	Control and drive of transmitter. For use with open wire aerial system	17.2
10D/19065	Transmitter Type T.4188	For use with suppressed or open wire aerial system	15.8
10D/19064	Receiver Type R.4187	For use with suppressed or open wire aerial system	26
10D/19067	Power and radio unit Type 4192	HT power supplies for transmitting circuits	34

TABLE 5
Connector schedule

The connectors in this schedule include those to the suppressed aerial equipment.

Destination sleeve marking		Remarks
End A	End B	
* Control unit Type 4190 (1A)	Power and radio unit (3A)	Pin to pin Wire 6145—100179 to Pin No. 1, 4, 5, 6, 7, 8, 9, 10, 11, 12, 13, 15, 16, 17, 18, 19, 20. Wire 6145—100229 to Pin No. 2, 3, 14
* Power and radio unit (3D)	Trans T.4188 (2D)	Pin to pin Wire 6145—100168 to Pin No. 3, 4, 5, 8, 10, 13, 14, 19, 20, 28. Wire 6145—100179 to Pin No. 6, 7, 9, 11, 12, 16, 17, 25, 27, 15. Wire 6145—100229 to Pin No. 1, 2, 24. Wire 6145—100249 to Pin No. 22

Table 5 (continued)

Connector schedule

Destination sleeve marking		Remarks
End A	End B	
Intercom connections		
		<i>Pin</i> <i>Colour</i> <i>Sleeve</i>
Power and radio unit (3F)	Intercom	1 Red Tel Pos
		2 Blue Tel Neg & E
		3 Green Mic
		4 Yellow Mic
		5 White Key
		6 Black Power SW
		7, 8 Earth (Screen)
		Sextometvinsmall 2.5
Note . . .		
<i>The length of the connectors will vary with the type of aircraft into which the installation is fitted.</i>		
TX shorting Plug (3J)		Pins 1 and 2 normally shorted
Power supply connections		
		3 off Unipren 12
* Recvr. R4187 (4M)	Power supply	Pin 4 1 3
		Sleeve 24V E 19V
Pin to pin		
		Wire 6145—100249 to Pin No. 1 Wire 6145—100179 to Pin No. 2, 3, 4
* Recvr. R4187 (4N)	Power and Radio Unit (3N)	Dupren 35, Unipren 12 Pin Nos. 1 to 10 cores to be marked "Earth" (Cable Dupren 35 blue)
* Power and radio unit (3P)	Power supply	Pin Nos. 13 to 20 cores to be marked '28V Pos.' (Cable Dupren 35 Red)
		Pin Nos. 11 and 12 cores to be marked '19V Pos' (Cable Unipren 12)
Recvr. R4187 (4AD)	Junction Box 4191 (12AD)	Pin to letter consecutive 25 Metvinsmall 2.5
Control unit 4190 (1AE)	Junction Box 4191 (12AE)	Pin to letter consecutive 25 Metvinsmall 2.5
** Control unit 4190 (1AF)	Selector unit (13AF)	Pin to Pin 1—25 25 Metvinsmall 2.5
** Selector unit (13AA)	Aerial control Unit 7216 (14AA)	Pin to letter consecutive 18 Metvinsmall 2.5
** Selector unit (1B)	Aerial Tuning unit (15AB)	Pin to letter consecutive 25 Metvinsmall 2.5
Control unit 4190 (1C)	Trans. T.4188 (2B)	Uniradio 32
Control unit 4190 (3E)	Trans. T.4188 (2C)	"
Power radio unit (3E)	Trans. T.4188 (2E)	"
Control unit 4190 (1L)	Recvr. R.4187 (4L)	"
** Control unit 4190 (1AG)	Imp. Match unit (16AG)	Uniradio 65
** Aerial tuning unit (15AC)	Imp. Matching unit (16AC)	12 Metvinsmall 2.5
J Box 4191 (12AH)	Control unit 4189 (11AH)	25 Metvinsmall Pin to Pin 1—25
* Voltage regulator	Supply	Pins 1 to 7 cores to be marked '24V Pos IN' Cable Dupren 35 Red Pin 12 core to be marked 'EARTH' cable Unipren 12. Pins 13 to 15 and 17 to 20 to be marked '19V Pos OUT' Cable Dupren 35 Blue
** Impedance matching unit (16AL)	Probe	Uniradio 43

Cables marked * are made up cables in polythene sleeving ; there are no miniature cables in use which would meet the requirements.

Cables marked ** are for suppressed aerial installations only.

RESTRICTED

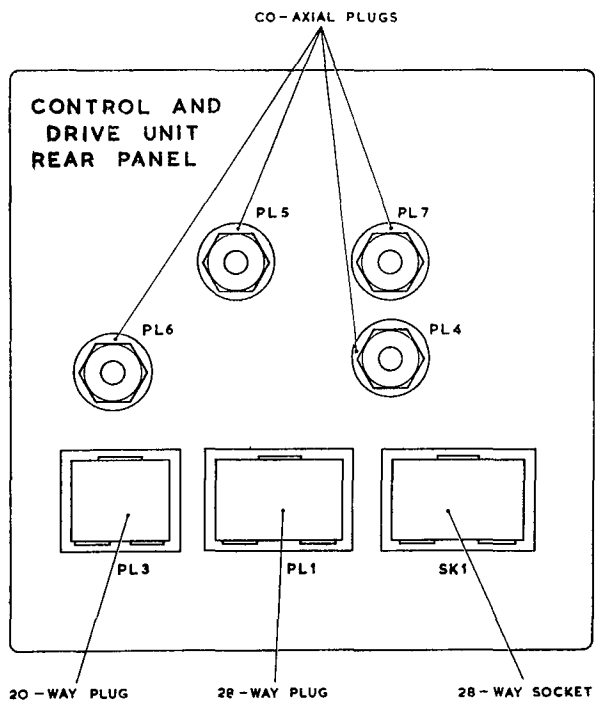
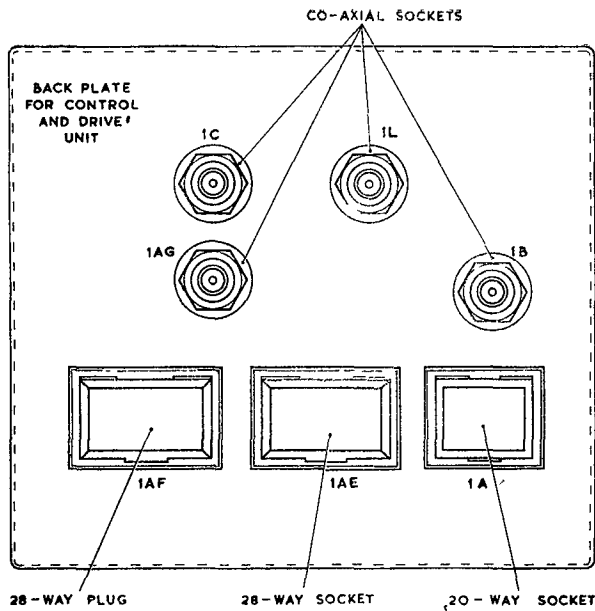

Fig. 5. Back-plate and connections to control unit Type 4190 or 4243

21. Against the sleeve marking at each end of the connector is a reference in brackets; this is the code marking appearing on the back-plate against the socket or plug termination of the particular connector (Table 1).

Equipment wires specification

22. The equipment wires referred to in Table 5 are listed in Defence Specification DEF-12 "Equipment Wires" (1st May, 1953) which includes the following note :—

"The American-British-Canadian Supply Classification (A.B.C.S.C.) 'Class' number for the wires specified in this DEF. Specification is 6145. This number and the item identification number shown in the tables make up the Catalogue number which should be quoted when reference is made to a particular wire, e.g., 6145-100168. Equipment wires shall be described by the Catalogue number followed by the name, type number, the conductor details and colour, e.g., 6145-100192 wire, electrical equipment, Type 2S, 7/0-0076 in Red".

Method of fitting back-plates with the aid of jigs

23. The method of fitting a back-plate to the racking system is shown in fig. 7. The associated jig (Table 1) is laid in a horizontal position across the rear ends of the left and right vertical side-members so that the jig runs parallel with the rear U-shaped channel member.

24. The back-plate is then lowered vertically at the back of the "turned-in" ends of the side members until the locating spigots on the back plate come to rest on the upper face of the rectangular jig.

25. With the back-plate and jig in this position the fixing bolts of the back-plate which pass through the "turned-in" ends of the side members, should be tightened until the back-plate is securely locked in position.

26. A further scrutiny should be made to ensure that the back-plate is properly aligned with the jig and the side members and the jig finally removed.

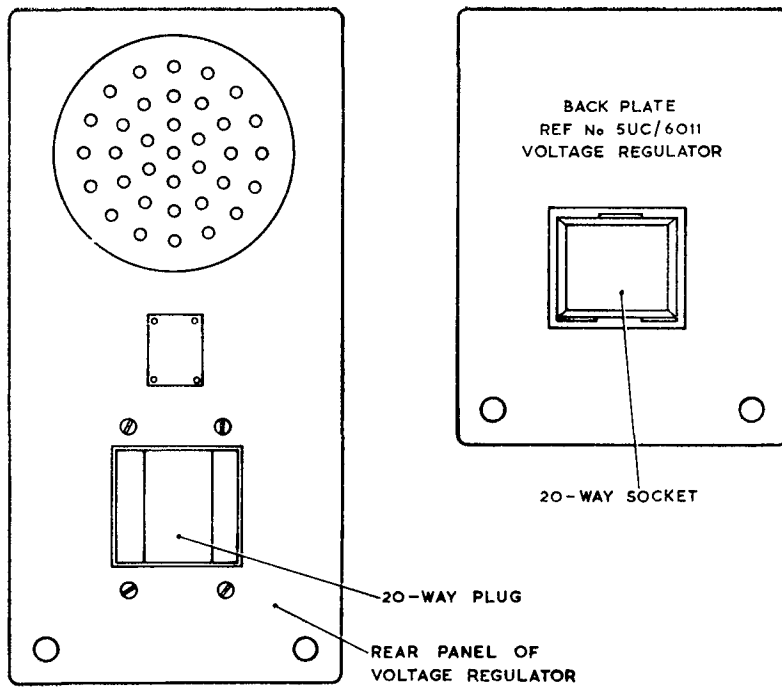

Fig. 6. Back-plate and connections to voltage regulator

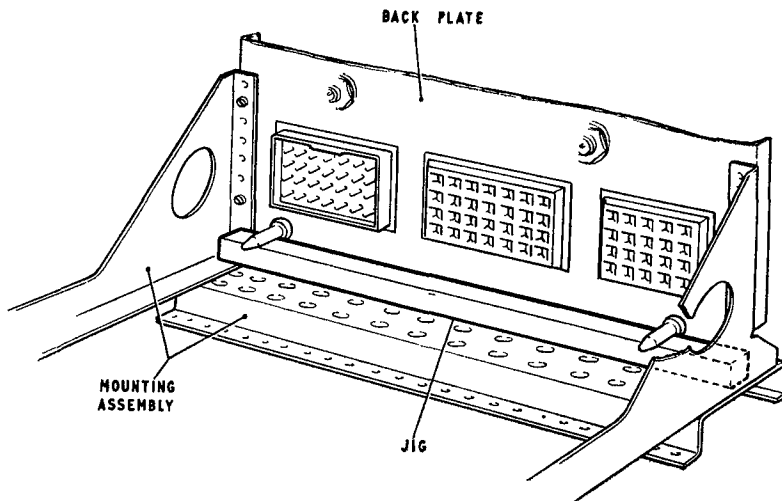
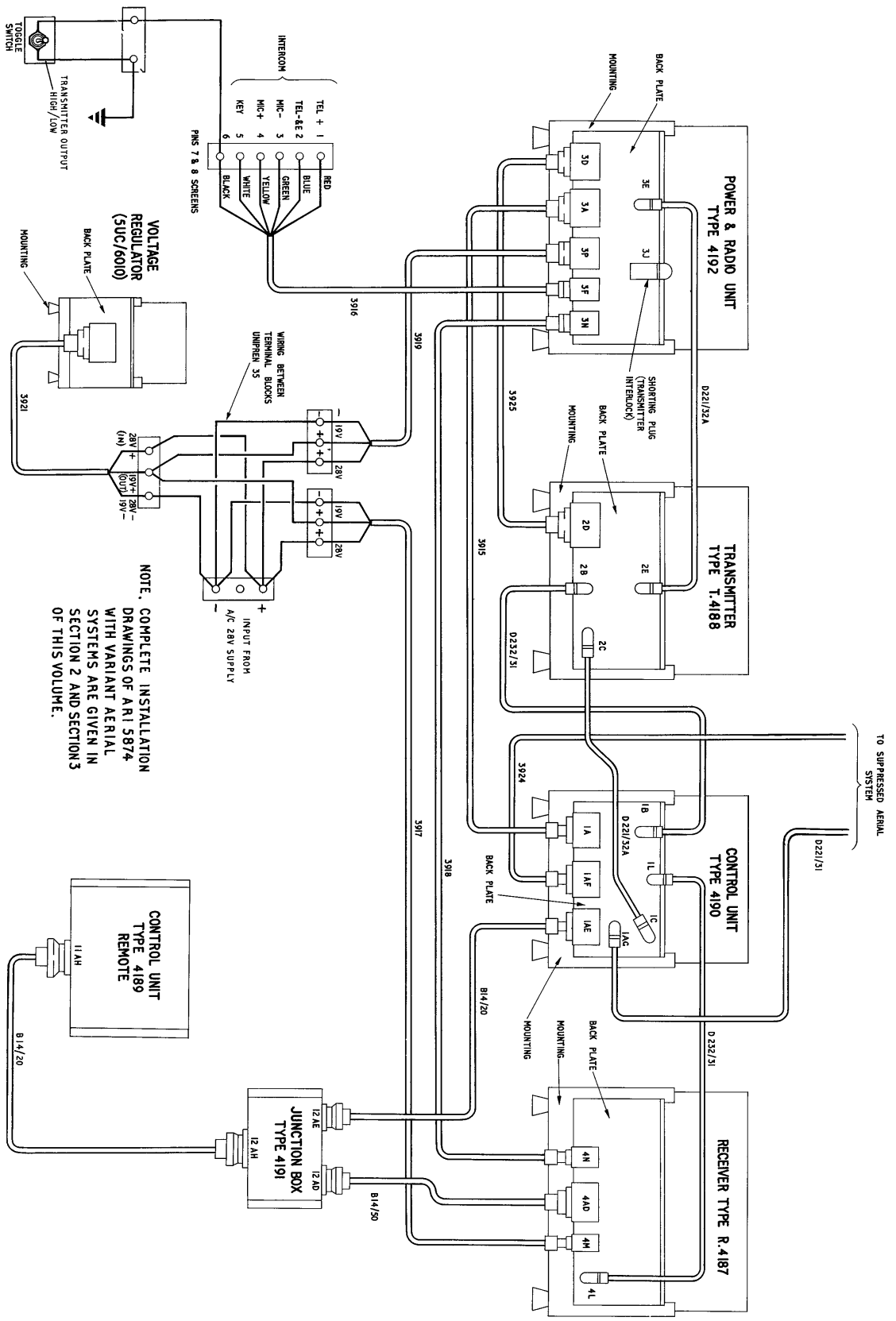

Fig. 7. Fitting back-plate with the aid of jig



NOTE. COMPLETE INSTALLATION DRAWINGS OF ARI 5874 WITH VARIANT AERIAL SYSTEMS ARE GIVEN IN SECTION 2 AND SECTION 3 OF THIS VOLUME.

Fig 8

ARI.5874 arranged for suppressed aerial system

RESTRICTED

469485 / 8136 625 155 881d Gp. 979

Fig 8

(A.L. 10, Nov. 54)

Chapter I

(This chapter supersedes that issued with A.L.11)

INTRODUCTION TO SUPPRESSED AERIAL SYSTEMS FOR ARI.5874

LIST OF CONTENTS

	Para.		Para.
<i>Introduction</i>	1	<i>General description</i>	30
<i>Wire aerials</i>	4	<i>Aerial system Type 7215</i>	33
<i>Suppressed aerials</i>	10	<i>Aerial system Type 9502</i>	42
<i>Practical schemes for HF suppressed aerials</i>	12	<i>Frequency coverage</i>	45
<i>First method</i>	13	<i>Frequency ranges</i>	46
<i>Second method</i>	14	<i>Impedance matching</i>	47
<i>Third method</i>	17	<i>Impedance matching units Type 7217 and 7949</i>	48
<i>Fourth method</i>	20	<i>Tuning units (aerial) Type 7015 and 7016</i>	57
<i>Suppressed aerial equipment</i>	24	<i>Inductor Type 7006</i>	71
<i>Coil energization equipment</i>	28	<i>Selector unit Type 7003</i>	76
<i>Notch and cavity energization equipment</i>	29	<i>Control unit Type 7216</i>	92

LIST OF ILLUSTRATIONS

	Fig.
<i>Sketch showing various methods of aircraft suppressed aerial installation</i>	1
<i>Main units of aerial system Type 9502</i>	2

INTRODUCTION

1. This chapter is prefaced with a discourse on the use of wire aerials on aircraft and the supersession of these by suppressed aerials for high-speed flying. Some of the information is of historical interest only, but is included to complete the account of the origin and subsequent development of various types of suppressed aerial described later in the chapter.

2. In this book we are concerned only with HF suppressed aerials as used with ARI.5874; these will vary slightly in shape, size and location according to the structure of the particular type of aircraft in which the equipment is installed.

3. It is perhaps hardly necessary to point out that wire aerials (fixed) are still used on the slower moving aircraft such as the Beverley. Fixed wire aerial equipment is described in Sect. 3.

Wire aerials

4. There are two forms of wire aerial which may be used on aircraft fitted with HF communications equipment. One is the now little used trailing aerial consisting of a thin wire trailed below the aircraft and extended to approximately a quarter-wave-length. The other is known as a "fixed aerial" and consists of one or more wires of convenient length attached to projections above the fuselage.

5. For both trailing and fixed wire aerials an aerial tuning unit is required. At different frequencies in the band the tuning unit will provide a suitable combination of capacitive and inductive loads to match the impedance presented by the aerial to that of the feeder and consequently to that of the transmitter output.

6. Wire aerials provide adequate signal voltages although at some frequencies their efficiency is poor. If the aerials are suitably designed, their mechanical reliability is satisfactory on aircraft flying at speeds of 200 to 300 knots.

7. Current trends for increased flying speed and for the operation of aircraft at high altitudes, together with the improvement in power output of the HF transmitters, makes the standard wire aerial impracticable for use with most modern aircraft.

8. The thickness of the wire aerial and the strength of the supports must be increased if they are to have sufficient mechanical strength at high speeds. Any projection beyond the aero-dynamic profile of the aircraft introduces a "drag" and a consequent limiting of both flying speed and operational range.

9. With the output power available in the modern transmitter, corona discharge to the atmosphere

RESTRICTED

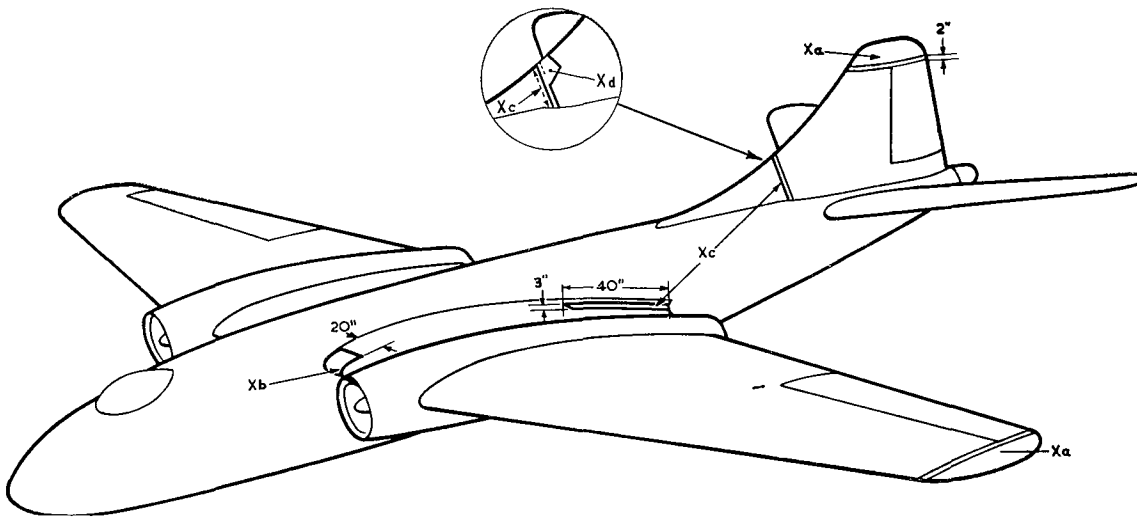

Fig. 1. Sketch showing various methods of aircraft suppressed aerial installation

will occur at heights in excess of 25,000 ft. and very little power will be radiated.

Suppressed aerials

10. From the foregoing it is clear that means other than conventional wire aerials must be used for HF radiation from the modern high speed aircraft.

11. Suppressed aerials may be generally described as arrangements by which radiation can be achieved without any physical projection outside the aerodynamic profile of the aircraft.

- (1) At very high frequencies it is often possible to mount the aerial in a plastic-covered cavity sunk into the skin of the aircraft. Scanners in Radomes are familiar examples of this.
- (2) At metric wavelengths the aerial lengths preclude the use of conventional radiators and arrangements are made to cause the RF currents to flow in the outer surface of the aircraft skin; this then becoming the radiating aerial. At very high frequencies this principle is also employed when a preferred aerial design can be so obtained.

Practical schemes for HF suppressed aerials

12. Four approaches to the problem have been found satisfactory from the radio viewpoint and capable of introduction on aircraft without major modification to the basic structure of the aircraft. The schemes are described with reference to the sketch in fig. 1.

First method

13. The extremity of either the tail fin or wing tip is constructed with about 2 inches of insulating material between it and the main fin or wing (fig. 1—*Xa*). This tip forms a capacitance to the main aircraft and, with the aid of a variable inductance connected in parallel (an aerial tuning unit), can be tuned to resonate at the operating

frequency. The RF voltage developed across the insulated break causes current flow on the skin surface and the wing or fuselage becomes the radiating aerial.

Second method

14. In the second method a coil or inductor is fitted in the leading edge of the wing in front of the main spar (fig. 1—*Xb*). The housing is provided with a plastic cover conforming with the wing profile. This inductor is tuned to resonance by a variable capacitance (aerial tuning unit) mounted in close proximity.

15. The inductor functions as a transformer primary to which the aircraft wing becomes the secondary. The magnetic field set up by RF current in the coil envelops the wing and induces current flow along it and along the fuselage itself. The inductor would function equally well in the trailing edge of the wing, but since a housing of about 20 in. long by 10 in. deep and wide is needed, the wing thickness at the trailing edge is usually too small to make a coil installation practicable.

16. Because of the limited radiation from this type of suppressed aerial, this method has now been superseded by cavity excitation as described in Method 4 (para. 20).

Third method

17. Where about 40 in. of trailing edge exists beyond the main spar of a wing near the root, a notch about 3 in. wide and 40 in. long (fig. 1—*Xc*) is cut into the surfaces. The edges of the notch are closed by a vertical diaphragm and a plastic cover is fitted.

18. An alternative arrangement, which may be used in an aircraft having a large dorsal fin, cuts a notch into this fin (fig. 1—*Xd*). With either arrangement the aerial tuning unit should be positioned (ideally) at the open end of the notch. In practice the tuning unit is usually housed in a compartment of suitable dimensions at the side of the notch.

RESTRICTED

19. In each arrangement the notch forms an inductance which can be tuned by a variable capacitance to resonate at the desired frequency. RF voltages developed across the opposite faces of the notch result in current flow along the wing and fuselage causing them to function as an aerial. Similarly, current may be set up in the fuselage and tail by introducing the notch into the dorsal fairing at the base of the tail fin (*fig. 1—Xd*).

Fourth method

20. From a subsequent development of Method 3 it was found possible to increase the inductive path provided by the boundary walls of the notch by including the space formerly used to house the aerial tuning unit. With such an arrangement the aerial tuning unit is mounted within the "cavity" thus formed and this greatly increases the radiated power at some frequencies in the operating band.

21. Early suppressed aerial installations incorporated designs based on methods 2 and 3. Later installations will incorporate the conception of "cavity" (Method 4) construction.

22. The cavity may have any shape convenient to the basic structure of the aircraft so long as adequate inductance is provided by the boundary walls. An inductance of approximately $1 \mu\text{H}$ has been obtained for cavity boundary walls with peripheries of the order of 100 inches. Such a cavity may be tuned to resonate over the HF frequency band with the same tuning unit as used with the notch system (Method 3).

23. This tuning unit provides for capacities of 100 to 5,000 pF and is mounted on one wall of the cavity with its terminal as near the mouth as practicable, this terminal being connected to the opposite side of the mouth by a suitable conductor such as a copper tube. This conductor provides inductance additional to that of the sidewalls of the cavity.

Suppressed aerial equipment

24. The second, third and fourth methods while differing in their structural requirements, use inductive energizing elements which require capacitance in parallel to tune to resonance over the band 2 to 30 Mc/s. The value of this capacitance is such that a similar aerial tuning unit can be employed with each system.

25. Potentials of the order of 2,000-3,000V will appear across the aerial tuning unit capacitor plates at some operating frequencies with the normal transmitter output of the order of 120 watts, 100 per cent modulation. Special care has been taken in the design of the inductor and the aerial tuning unit to ensure that operation may be safely undertaken at very high altitudes.

26. For this reason the aerial tuning unit is enclosed in a pressurized container and large diameter tubing is used in the construction of the inductor. Scrupulous cleanliness must be observed

in servicing and great care must be observed when making repairs to avoid any action which may impair the highly polished finish of the component parts.

27. Systems employing methods 3 and 4 have been introduced into the Valiant, Vulcan and Victor. In all these aircraft the aerial system is required to operate with a multi-channel preselected and remotely-controlled transmitter. It follows, therefore, that the aerial tuning unit must have an automatic function which will operate when a channel-change process takes place in the transmitter.

Coil-energization equipment

28. The component units of an automatically tuned coil-energized suppressed aerial system are detailed as follows:—

- (1) The inductor unit. This is the coil mounted in the cavity in skin, (*fig. 1—Xb*). The inductor has a centre tapping permitting two or four turns to be used as required.
- (2) The impedance matching unit. A motor-driven switching assembly which connects two or four turns of the inductor into the resonating circuit and switches variable lengths of inductance between the low voltage end of the inductor and "earth" to match its feed point to the feeder cable and transmitter.
- (3) The aerial tuning unit. A motor-driven variable capacitor with a range switch which determines the proportion of the total variable capacitance utilized in each section of the operating frequency band.
- (4) The selector unit. A 24-channel selecting system deriving "channel required" information from the transmitter. Provision is made for presetting the switching and capacitance values required for each channel. Remote control mechanisms pass the tuning information to the aerial tuning unit and the impedance matching unit.
- (5) The control unit. The control unit is mounted on the operator's table and is designed to give him the choice of automatic or manual operation of aerial tuning. Switches for the selection of frequency range and manually controlled capacitor tuning are provided. Aerial current is shown on a "tune" meter and operational faults are indicated by a lamp.

Notch and cavity energization equipment

29. For suppressed aerial systems using the notch or cavity method of energization, the component items are as follows:—

- (1) The notch-cut in the trailing edge of the aircraft wing or the cavity cut into a

RESTRICTED

suitable part of the wing or dorsal fin which functions as the aerial tuning inductance.

- (2) The impedance matching unit. This is a motor-driven switch connecting the feeder to the point along one wall of the notch or cavity at which the optimum matching to the feeder cable impedance can be obtained for each operating frequency.
- (3) Aerial tuning unit. This is similar to that used for Method 2 but with additional capacity in the form of a fixed capacitor, sections of which can be switched-in according to the frequency band in use.
- (4) Selector unit. As for coil-energization.
- (5) Control unit. As for coil-energization.

GENERAL DESCRIPTION

30. Two suppressed aerial systems have so far been devised for use with ARI.5874. The first has been superseded by the second.

- (1) Aerial system Type 7215—coil energization (now superseded).
- (2) Aerial system Type 9502—Notch or cavity energization.

31. In each case the aerial system becomes a part of ARI.5874. Aerial system Type 7215 was fitted to the early Valiants, but is now superseded on that aircraft by the aerial system Type 9502. The latter is also fitted to the Vulcan aircraft, both the Valiant and Vulcan are cavity-excited.

32. Development on the Victor embodies the aerial system Type 9502 with the application of Method 4, that is to say, the entire aerial system is virtually outside the skin of the aircraft (*para.* 20).

Aerial system Type 7215

33. The aerial system Type 7215 as used with ARI.5874 is designed to feed RF energy to the aircraft structure so that the latter becomes a radiator of the transmitter output power at any selected frequency within the band 2.8 to 18.1 Mc/s.

34. Coupling to the aircraft structure is effected by a coil (inductor Type 7006) mounted at a suitable point on the wing, usually on the wing root. The metallic surface of the wing is cut away in the vicinity of the coil and covered with a "window" of insulating material.

35. The aperture in the wing enables the electromagnetic field around the coil (which would otherwise be totally enclosed within the metallic structure) to couple with the surface of the wing and induce RF currents in the wing structure.

36. Since the wing represents a widely distributed mass of conducting material it exhibits no sharp resonances despite the fact that its dimensions may be such as would be expected to give rise to resonance phenomena at some frequencies in the band.

37. The reactance of the coupling coil itself, together with any reactance transferred to it from the wing, is tuned out by a variable capacitor (aerial tuning unit) so that the arrangement may be regarded as approximating to an under-coupled transformer with tuned primary and with an untuned, or flatly tuned, secondary.

38. Although the reactance of the system is tuned out, the remaining resistive load will in general be unsuitable for direct connection to the transmitter output; therefore a small tapped inductor (impedance matching unit Type 7217) is connected in series with the main inductor to form an auto-transformer for matching purposes.

39. The low impedance output from the transmitter is fed via a coaxial cable to one of a series of tapping points on the small inductor, the tap being changed at appropriate intervals in the band to ensure that the system represents an adequately matched load at all frequencies.

40. The frequency band to be covered is divided into six ranges. The inductor Type 7006 is centre-tapped and the variable capacitor in the aerial tuning unit is divided into four sections; switches are provided to select the combinations required for the frequency range in use.

41. It is not necessary to vary the feeder tapping point continuously and, in practice, only one tap is used for each range; the tapping point being selected to give the best compromise over that range. A considerable overlap exists between ranges and there is normally a choice of at least two ways of setting up any desired frequency. The arrangement is such that, over the central part of the band, there are available two L/C ratios in addition to the alternative tapping points.

Aerial system Type 9502

42. With the aerial system Type 9502 the tuned aerial circuit is formed by the cavity or notch in the aircraft structure and the variable capacitor of the tuning unit Type 7016. This circuit is automatically brought into resonance at the operating frequency of the transmitter-receiver equipment by the selector unit Type 7003, (*fig.* 2).

43. At the same time the impedance matching unit Type 7949 makes the necessary change in the cavity tapping point to preserve an adequate match between the dynamic impedance of the loaded tuned circuit and the 70-ohm aerial feeder.

44. The control unit Type 7216 makes it possible for these operations to be carried out directly by the operator if the automatic system fails, or if operation is required at a frequency not included when the system was set up before flight.

Frequency coverage

45. The frequency band covered by the aerial system is the same as that for the transmitter-receiver equipment; 2.8 to 18.1 Mc/s. This band is too great to be covered easily by a single variable capacitance which would give a very cramped

RESTRICTED

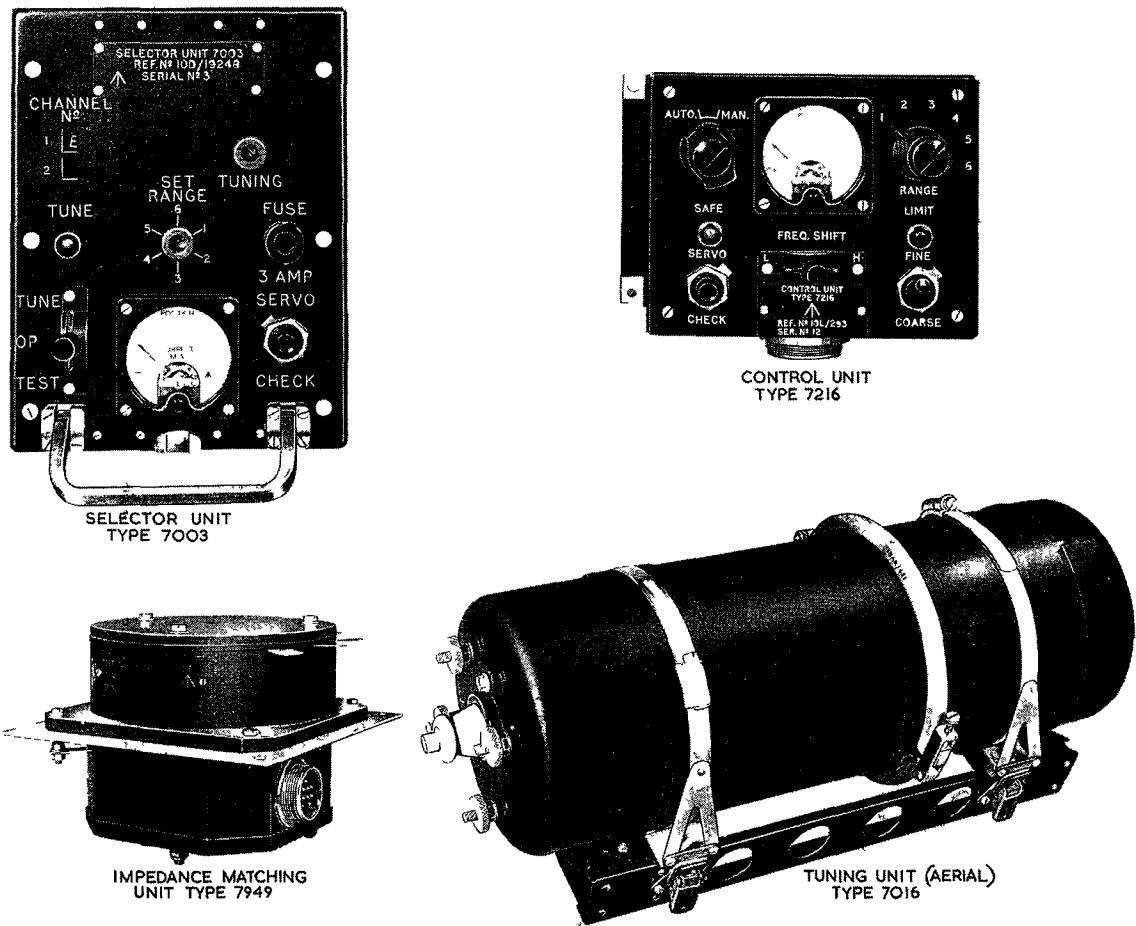

Fig. 2. Main units of aerial system Type 9502

frequency scale and make accurate tuning very difficult. Therefore the tuning unit capacitor is sub-divided into three variable and three fixed sections with one variable section permanently in circuit and the others brought in by a switching device according to the range selected.

Frequency ranges

46. A cam-operated switch gear is provided to enable the sections of the capacitor to be selected to give a total of six frequency ranges. There is a considerable amount of overlap in the frequency coverage of the various ranges; this factor is valuable in selecting the best working condition for a particular aircraft installation.

Impedance matching

47. In order to simplify the matching arrangements, continuously variable tapping is not used and six preset tapping positions are provided by the impedance matching unit (*para.* 48).

Impedance matching units Type 7217 and 7949

48. The impedance matching unit Type 7217 used in the "coil" system is connected between the low potential end of the inductor Type 7006 and "earth". It contains the switches necessary for

selection of the appropriate tapping point for feeder input and for changing over from full to centre-tap on the main inductor.

49. The matching inductor has an inductance of about $0.8 \mu\text{H}$ and is a compact helix formed of one quarter-inch diameter copper tube; the tube is connected to the terminals of the associated tapping switch by silver-plated copper straps.

50. To switch the taps on the main inductor a separate switch section in the impedance matching unit is used. This is arranged so that the centre-tap is employed for ranges 1 to 3, and the whole inductor for ranges 4 to 6.

51. The main inductor is connected to this switch by flexible connectors, terminating in heavy-duty plug and socket joints with knurled retaining caps. The switches are motor-driven through a suitable gear train, their position being controlled by wafer switch on the same shaft; this switch is incorporated in a line-finder servo system.

52. For monitoring the RF output, provision is made for the connection of a small probe wire which picks up a portion of the RF output from the

RESTRICTED

main inductor. The probe is connected in a detector circuit which provides two DC outputs of opposite polarity to operate meters at suitable monitoring points.

53. Impedance matching unit Type 7949 is for use with cavity or notch suppressed aerials. It is designed to maintain a reasonable match between the input impedance of the aerial system and the output impedance of the transmitter at all frequencies within the band.

54. The unit has a completely enclosed switch with "strap" connections to points on the walls of the cavity. The helical matching inductor and the coil tapping switch of the earlier impedance matching unit is omitted.

55. Selection of the particular impedance-matching tap is dependent on which of the six frequency ranges is selected in the aerial tuning unit. The matching unit changes the tapping point on the wall of the cavity in the aircraft and thus the size and shape of the cavity.

56. A separate connection on the cavity wall provides a probe to a rectifying circuit in the impedance matching unit; the output from this circuit provides a visual indication of aerial output.

Tuning units (aerial) Type 7015 and 7016

57. The tuning unit Type 7015 is located immediately adjacent to the exciting coil either within the leading edge of the aircraft wing or in the fuselage if the coil is mounted close to the fuselage.

58. Since the tuning unit has to be mounted adjacent to the exciting coil and therefore outside the pressure cabin of the aircraft, the electrical components of the tuning unit are enclosed in a sealed pressurized canister. This canister is constructed from mild steel in two parts which, when clamped together, form an airtight container. The container is fitted with a Schrader valve to enable it to be filled with dry air at about 5 lb./sq. in. above normal atmospheric pressure (*para.* 65).

59. All the electrical components of the tuning unit, with the exception of the outer plug connections, are mounted on a casting within the pressurized canister.

60. The tuning unit contains part of the switching arrangement by which the total frequency band (2.8 to 18.1 Mc/s) is divided into six ranges by changing the L and C values. The "L values" are not within the tuning unit but are changed by a motor-driven range switch (in the impedance matching unit) which actuates tapping switches on the exciting coil and the inductor in the matching unit.

61. Remote control of the motor-driven range switches in the tuning unit and the impedance matching unit is provided by a simple 6-way line finder circuit from the aerial selector unit (*para.* 76). Continuous tuning over each range is achieved by the use of a motor-driven variable air-spaced capacitor in the tuning unit.

62. The motor drive is remotely controlled from the selector unit by a Wheatstone-bridge servo system similar to that used to tune the transmitter and the receiver (*Sect.* 1). The range switch in the tuning unit switches in sections of the variable capacitor according to the range in use. The capacitor motor can be manually controlled and the capacitor driven in either direction by switching at the control unit Type 7216 (*para.* 92).

63. The tuning unit, therefore, contains the 4-section variable capacitor with its associated sectioning switches, and two motors for driving these and the rotor of the capacitor. Coupled to the rotor shaft of the capacitor is the wiper of the toroidal potentiometer which forms part of the Wheatstone-bridge servo system used for automatic tuning. "Limit" spring-sets are provided to stop the drive, and light a warning lamp on the control unit Type 7216, when the rotors reach either limit of their travel.

64. The sectioning switches are operated by a ceramic camshaft, the position of which is controlled according to the frequency range required, by a simple line-finder system. The wafer switch used as the controlling element for this system is ganged to the camshaft and to a similar wafer switch used for repeating the "range" information out to the impedance matching unit, to control the selection of associated inductance values.

65. Because of the high voltages developed across the tuned circuit the plate separation of the capacitor is necessarily large, but it would be quite impracticable to make it large enough to withstand the full voltages at altitudes greater than about 15,000 ft. The pressure in the canister is therefore, maintained at about 20 lb. per square inch absolute, so as to obviate the necessity for voltage derating at altitude.

66. A pressure-operated switch indicates by means of a proving lamp that the pressure in the canister is being maintained. A similar switch, set to operate at about 11 lb. per square inch absolute, is used to reduce the transmitter power automatically should a leak develop at altitude. This arrangement permits the continued operation of the transmitter under reduced power, when breakdown would occur under full-power operation.

67. Tuning unit Type 7016 is similar in construction to tuning unit Type 7015 but is designed to give greater maximum capacitance than the latter. The unit consists mainly of an electro-mechanical drive unit driving a 3-section variable capacitor in association with a fixed capacitor switched in three sections from the same device. The fixed capacitor has been added because it would not be practicable to accommodate a fully variable capacitor of the required value in the space available.

68. Since the tuning unit has to be mounted in or adjacent to the cavity in the airframe, it will be located outside the pressure cabin and therefore subjected to extreme changes in atmospheric pressure. To obviate the effect of reduced pressure

RESTRICTED

under working conditions at high altitudes the capacitor (and the drive unit) are completely enclosed in a pressurized canister. This canister is somewhat longer than that of the tuning unit Type 7015.

69. As with the tuning unit Type 7015, the canister is pressurized in service to about $5\frac{1}{2}$ lb. per sq. in. above atmospheric pressure. Two pressure-operated switches are fitted and one of these operates the SAFE lamp on the control unit Type 7216. The SAFE lamp is extinguished if the pressure in the canister falls below 16 lb. per sq. in. absolute, thus indicating the necessity of re-pressurization and/or leakage check.

70. The second pressure-operated switch automatically switches the transmitter to the "low power" condition when as a result of further decrease of pressure within the unit, operation at full power would entail a risk of RF breakdown.

Note . . .

Although voltages encountered in the "cavity" system are lower than those of coil-energization, maximum values being about 2.5 kV peak, the capacitor spacings are smaller, and unsuitable to withstand this voltage if the canister pressure falls far below atmospheric pressure.

Inductor Type 7006

71. The inductor Type 7006 was fitted to some early Valiant aircraft but is now being superseded by cavity-excitation. A brief description of the inductor follows:—

72. The inductor would normally be mounted in the leading edge and near the root of one of the aircraft wings. The leading edge of the wing has to be constructed in insulating material over the portion occupied by the coil and approximately 20 inches of length of the leading edge is required for the coil mounting.

73. The coil is of large superficial area and has an inductance of about $4 \mu\text{H}$ with a centre tapping giving about $2 \mu\text{H}$. It is formed from half-inch diameter copper tube and has four turns spaced two inches apart; the approximate overall dimensions of the coil are $8\frac{1}{2}$ in. high by 16 in. long by $5\frac{1}{2}$ in. front to rear. The coil is silver-plated to minimize losses.

74. One end of the coil passes through an insulating bush in the side of the wing root to an insulated terminal at one end of the tuning unit. The other end and the central tapping point of the coil are connected to the impedance matching unit. A probe wire is mounted in close proximity to the back of the coil; it is secured to the insulated mounting bracket.

75. A short section of bellows construction is interposed between each terminal and the end of the coil to provide flexibility of mounting between

the coil, the tuning unit and the impedance matching unit.

Selector unit Type 7003

76. The selector unit Type 7003 contains the master elements for all the servo systems. Basically, it consists of a turret which can be rotated by a motor to any one of 24 possible positions. The turret is divided into two sections, the front section having 24 preset 6-position cams and the rear section having 24 lead-screws each bearing a travelling contact; the contact positions are preset by means of the lead-screws.

77. All the 6-position cams and the lead-screws have screwdriver slots with access through the front panel. When in the operating position, each can be set up through an access hole in the panel; retaining springs prevent accidental disturbance of the controls after setting.

78. At any position of the turret, one of the preset cams is in mesh with one of the six springsets mounted beneath the turret. Each cam is provided with an index mark and alignment of this mark with any required range number on the front panel (1 to 6) causes the associated springset to be closed and thus to "earth" one of the six range control lines.

79. A relay then operates and starts the range motor in the tuning unit until an associated waver switch isolates the tuning unit end of the line. In this process the tuning unit camshaft is rotated to the correct position for the range selected and the information repeated to the impedance matching unit.

80. In the impedance matching unit an exactly similar system in association with a relay in the selector unit causes the correct tapping point on the inductors to be selected.

81. Again, for any position of the turret, one lead-screw contact is in mesh with a fixed potentiometer winding on a sprung cylindrical former, whose axis is parallel to the turret axis.

82. The preset contact in use can be moved along the selector unit potentiometer winding by turning its lead-screw (by means of a screw-driver) through the access hole in the front panel (*fig. 2*). This has the effect of varying the resistance ratio in the two arms of the Wheatstone Bridge formed by this potentiometer.

83. Connect between the preset contact and the wiper of the tuning unit potentiometer, which forms the other pair of bridge arms is a polarized relay. This is associated with slave relays employed to control the direction of rotation of the tuning motor in the tuning unit.

84. Circuit arrangements are such that any unbalance in the bridge circuit is made to operate the correct slave relay to drive the wiper of the

RESTRICTED

tuning unit potentiometer towards the balance position, where it finally stops. Since the capacitor rotors are on the same shaft, the arrangement enables their position to be controlled by the position of the preset contact.

85. The tendency of systems of this type to "hunt" (*i.e.* to oscillate continuously about the equilibrium position) is overcome by a mechanical device in the tuning unit. This makes the first reversal of drive caused by an overshoot past the balance condition bring a reduced drive speed into operation and so prevent further overshoots.

86. A meter is provided on the front panel for observation of RF output during setting-up; this meter can also be used, by pressing a button, to indicate the existing setting or orientation of the capacitor rotors. From this information the operator will be aware of the direction of rotation required to establish any new settings.

87. To facilitate the setting-up operation, a key switch is provided at the front panel with which the transmitter can be keyed at full power or at slightly reduced power.

88. Normally the key circuits are rendered inoperative during channel selection and while the tuning or switching motors are running, but during reduced power operation the key circuits are not disabled by the tuning. This enables the variation of RF output to be observed while tuning is in progress and greatly facilitates adjustment to resonance.

89. When any channel has been set up, the next can be chosen by the transmitter channel selection system. The selection will cause the turret to be driven by its motor until the appropriate fresh pair of preset controls is brought into mesh.

90. An indicator fitted to the turret enables the operator to verify that it has taken up the correct position for the channel in use. Once the preset controls for any channel have been correctly adjusted, reselection of that channel will provide the servo systems with the information necessary to repeat the desired settings.

91. In addition to the relays required for the functions described above, the relay units in the selector unit chassis contains those relays associated with the additional facilities provided by the control unit Type 7216.

Control unit Type 7216

92. The principal function of this unit is to enable the operator to take direct control of range selection and tuning in the event of part failure of the automatic system, or if operation is required at a frequency which is not set up at the selector unit. The control unit can also be used to facilitate the setting up process.

93. A meter is provided on the control unit to monitor the RF output in order that resonance may be observed. This meter can be switched into the servo system to verify that the capacitor is being driven.

94. Range selection is carried out by a 6-position switch and tuning is achieved by the use of a sprung key-switch which enables the tuning motor to be run in either direction. Two tuning speeds are available under the control of a COARSE/FINE switch (*fig. 2*).

95. During COARSE tuning the transmitter is automatically switched to low power to prevent excessive P.A. currents resulting from severe detuning; shunts on the RF meter are changed at the same time to preserve an adequate reading. On switching to FINE tuning the full power condition is automatically restored.

96. The FINE tuning facility can also be employed to enable the operator to make small readjustments of tuning during automatic operation without disturbing the preset adjustments in the selector unit.

97. Normally, the tuning capacitor settings are repeated by the servo system with sufficient accuracy to keep the power loss due to detuning within 1 dB, but changes in the tuned circuit constants resulting from temperature variation may occasionally warrant the use of manual correction.

98. The lamp used to indicate that the capacitor rotors have reached either limit of their travel is incorporated in the control unit; this is engraved LIMIT. Another lamp is fitted (engraved SAFE) and is employed in conjunction with the pressure-operated switch in the tuning unit (*para. 66*) to provide a means of checking that the pressurization of the latter is maintained.

RESTRICTED

Chapter 2

SELECTOR UNIT TYPE 7003

LIST OF CONTENTS

	Para.		Para.
General description	1	Monitoring circuit	54
Mechanical function and circuit description ...	17	Centre-stable relay, and Wheatstone servo ...	58
Relay unit Type 7332	18	Fine tuning relays	79
Channel selection relay and switching circuits ...	20	Keying (tune) interlock	88
Manual operation circuits	33	MANUAL operation	92
Range and matching relays	36	AUTO operation	95
Automatic range selection	40	Setting-up	96
Tuning relays	43	Test lamp circuit	97
		TUNE operation	99
		Low power operation and RF monitoring ...	103

LIST OF TABLES

	Table
Function of relays, magnetic (Z.530453) in selector unit	

LIST OF ILLUSTRATIONS

	Fig.		Fig.
Front panel of selector unit	1	Selector unit underside of chassis	3
Turret switch and drive unit on selector unit chassis ...	2	Selector unit Type 7003—circuit	4

GENERAL DESCRIPTION

1. The selector unit Type 7003 contains the master elements for all the Servo channel selection and tuning systems in the suppressed aerial system. The selector unit consists, basically, of a motor-driven turret switching device which can be rotated to any one of 24 possible positions. The selected channel information is relayed from the control and drive unit of the associated transmitter equipment.

2. The motor-driven turret switch is divided into two sections, the front section having 24 preset 6-position cams and the rear section having 24 lead-screws each bearing a travelling contact; the contact positions are preset by means of the lead-screws.

3. All the 6-position cams and the lead-screws have screwdriver slots with access through the front panel (*fig. 1*). When in the operating position, each can be set up through an access hole in the panel; retaining springs prevent accidental disturbance of the controls after setting.

4. A general view of the turret switch is given in *fig. 2*. At any position of the turret, one of the preset cams is in mesh with one of the six springsets mounted beneath the turret. Each cam is provided with an index mark and alignment of this mark with any required range number on the front

panel (1 to 6) causes the associated springset to be closed and thus to "earth" one of the six range control lines.

5. A relay operates at this point, and runs the range motor in the tuning unit until an associated wafer switch isolates the tuning unit end of the line. In this process the tuning unit camshaft is rotated to the correct position for the range selected and the information repeated to the impedance matching unit.

6. In the impedance matching unit an exactly similar system in association with a relay in the selector unit causes the correct tapping point on the inductors to be selected.

7. Again, for any position of the turret, one lead-screw contact is in mesh with a fixed potentiometer winding on a sprung cylindrical former, whose axis is parallel to the turret axis.

8. The preset contact in use can be moved along the selector unit potentiometer winding by turning its lead-screw (by means of a screwdriver) through the access hole in the front panel. This has the effect of varying the resistance ratio in the two arms of the Wheatstone bridge formed by this potentiometer.

9. Between the preset contact and the wiper of

RESTRICTED

the tuning unit potentiometer which forms the other pair of bridge arms, is connected a centre-stable relay. This is associated with slave relays employed to control the direction of rotation of the tuning motor in the tuning unit.

10. Circuit arrangements are such that any unbalance in the bridge circuit is made to operate the correct slave relay to drive the wiper of the tuning unit potentiometer towards the balance position, where it finally stops. Since the capacitor rotors are on the same shaft, the arrangement enables their position to be controlled by the position of the preset contact.

11. The tendency of systems of this type to "hunt" (i.e. to oscillate continuously about the equilibrium position) is overcome by a mechanical device in the tuning unit. This makes the first reversal of drive, caused by an overshoot past the balance condition, bring a reduced drive speed into operation and prevents further overshoots.

12. A meter is provided on the front panel for observation of RF output during setting up; this meter can also be used, by pressing a button, to indicate the existing setting or orientation of the capacitor rotors. From this information the operator will be aware of the direction of rotation required to establish any new settings.

13. To facilitate the setting-up operation, a key switch is provided on the front panel with which the transmitter can be keyed at full power or at slightly reduced power.

14. Normally the key circuits are rendered inoperative during channel selection and while the tuning or switching motors are running, but during reduced power operation the key circuits are not disabled by the tuning. This enables the variation of RF output to be observed while tuning is in progress and greatly facilitates adjustment to resonance.

15. When any channel has been set up, the next can be chosen by the transmitter channel selection system. The selection will cause the turret to be driven by its motor until the appropriate fresh pair of preset controls is brought into mesh.

16. An indicator fitted to the turret enables the operator to verify that it has taken up the correct position for the channel in use. Once the preset controls for any channel have been correctly adjusted, reselection of that channel will provide the servo systems with the information necessary to repeat the desired settings.

MECHANICAL FUNCTION AND CIRCUIT DESCRIPTION

17. It is not possible to describe the complete circuit operation of the selector unit without considering the overall circuit of the aerial system. This circuit description is therefore limited to the automatic relay circuits and channel selection devices. The tuning circuits are described in the complete circuit description of the aerial system Type 7215 (*Chap. 7*).

Relay unit Type 7332

18. Relay unit Type 7332 (10F/17951) is mounted on the underside of the selector unit Type 7003 as illustrated in fig. 3. On the relay sub-chassis are mounted 13 magnetic relays one of which is the sensitive centre-stable relay BR/2. This is a single-pole change-over polarized relay with one make contact each side; it has two coils of 350 ohms each and operates with a nominal current of 100 μ A. The designation is relay, magnetic Type 1538 (10F/17952).

19. The remaining twelve relays are all of one type, viz., relays, magnetic, 24V (Z530453). These are a sealed miniature type with two sets of contacts and coil resistance 700 ohms. The circuit function of the relays is given in Table 1.

Channel selection relay and switching circuits

20. The function of the channel selection circuits is to cause the rotation of the turret until it takes up the position bringing the SET RANGE and TUNING preset controls (*fig. 1*) appropriate to the selected channel into operation.

21. All the circuits necessary for carrying out this operation are contained in the mechanical drive unit Type 7333. The control circuits are designed to work in conformity with the method of channel identification used in the transmitter-receiver equipment, the channels being divided into two groups of twelve, each channel being designated by one of the letters A to M and the numbers 1 or 2 (*Sect. 1*).

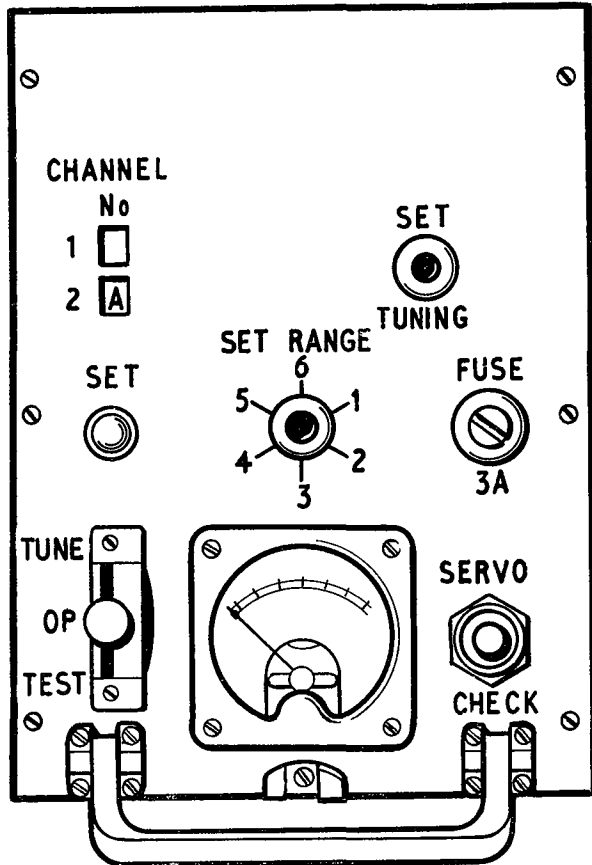

Fig. 1. Front panel of selector unit

TABLE I
Function of relays magnetic (Z530453) in selector unit

Relay	Circuit description	Circuit function
CSA, CSB	Channel selection relays	Relays CSA and CSB control the operation of the channel selector motor CSM which in turn controls the tuning of the aerial system according to the channel selected in the transmitter-receiver system.
NR	Number relay	Operated by channel number switching in transmitter-receiver system.
AMA, AMB	Auto-manual relays	Provides circuit conditions for either automatic or manual tuning according to position of AUTO/MAN switch on control unit Type 7216.
TL, TH	Tuning relays	These relays are arranged to drive the tuning motor of the aerial tuning unit in either direction to reach conditions of aerial resonance.
BR	Centre-stable relay forming part of Wheatstone servo system	Selects tuning relays TL or TH to drive tuning motor in direction required to reach aerial resonance.
FTA, FTB	Fine tuning relay	Give conditions of fine tuning for manual operation or for fine adjustment after automatic tuning.
RR	Range relay	Operates range switch motor in tuning unit for selection of range appropriate to channel selected at transmitter-receiver system.
MR	Matching relay	Operates matching motor in impedance matching unit for selection of impedance matching appropriate to channel selected at transmitter.
MS	Meter shunt relay	Changes meter shunts in control unit Type 7216 and selector unit to give adequate readings under conditions of low power operation.

22. The switch S1 controlling the position of the turret has 24 positions, the position sequence being 1A, 2A; 1B, 2B; 1C, 2C; and etc. The stator tags are strapped together in pairs, 1A and 2A, 1B and 2B, etc.

23. One control line is brought out from each pair of stator tags and provides the "channel letter" control, the channel selection being made by switch S3D in the control unit Type 4190 (Sect. 1). The "channel number" control is provided by a pair of springsets S2 and S3.

24. The springsets S2 and S3 are operated by a specially designed cam in the drive unit (*fig. 2*). This cam makes six revolutions for each revolution of the switch spindle (S1) and has two pairs of "lifts." One "lift" is arranged to close the springset S2 twice per revolution of the cam, i.e. twelve times per revolution of the switch. The other "lift" operates springsets S3 in a similar manner, but its operating positions are displaced 90 deg. from those of the springset S2.

25. Because of the 6-to-1 gearing between the camshaft and the switch shaft, the latter moves 30 deg. between any two consecutive closures of S2 or S3, but only 15 deg. between any closure of S2 and the next closure of S3 and vice versa. Since the 24 positions of switch S1 are at 15 deg. intervals, it follows that springset S2 is closed when S1 is in any of the positions 1A, 1B, 1C, etc. Springset S3 will be closed in the intermediate positions 2A, 2B, 2C, etc. The operation in the two conditions is fully illustrated in Chap. 9.

26. From the above, it follows that "channel number" selection is merely a matter of selecting the circuit containing either springset S2 or S3; the choice is made by the "channel number" relay NR/2 (contact NR1).

27. Suppose that channel 1A is selected at the remote control unit of the transmitter-receiver equipment, with the (aerial) control unit Type 7216 set to AUTO. The channel selection mechanism of the control unit Type 4190 will operate first; when it

RESTRICTED

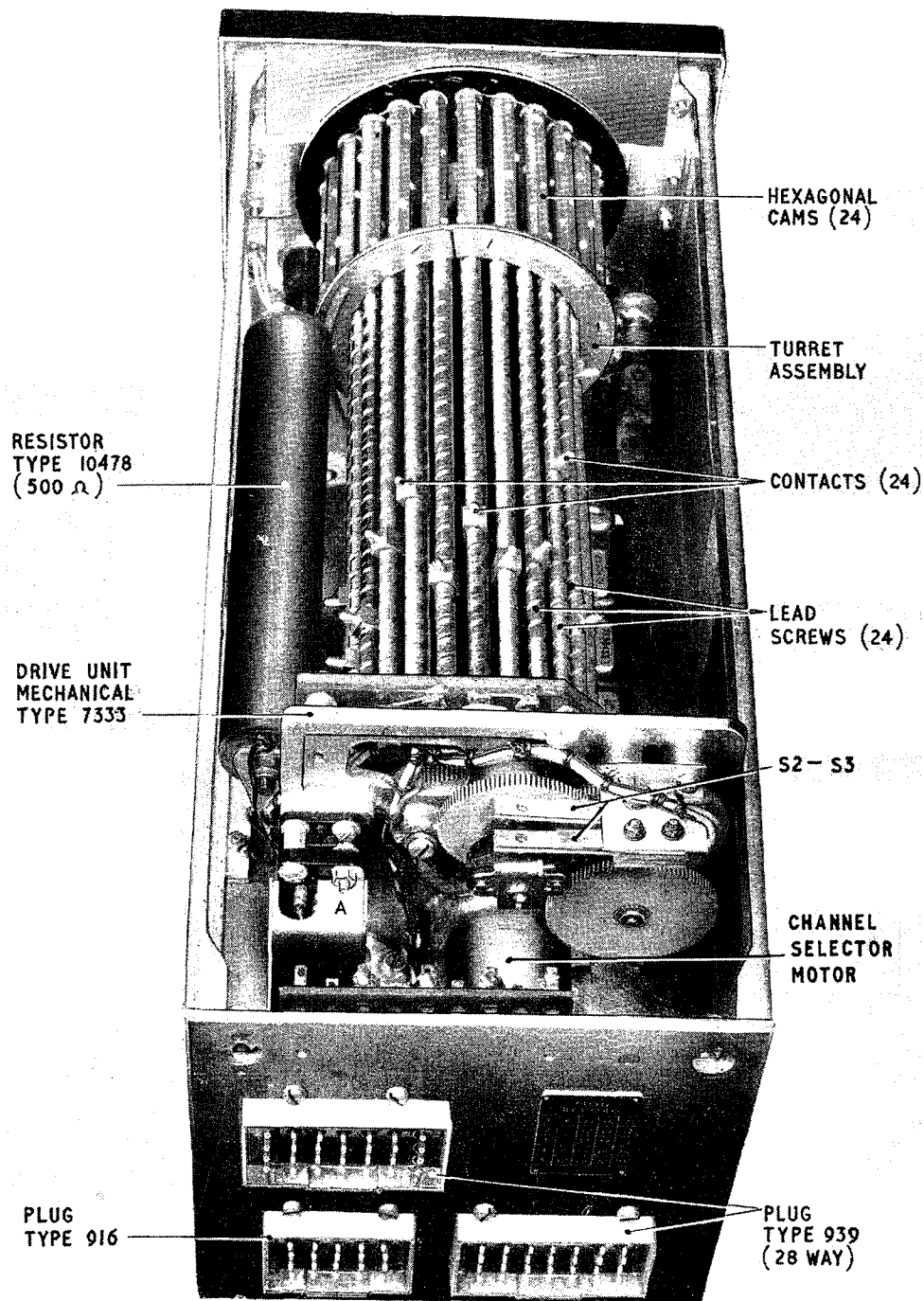

Fig. 2. Turret switch and drive unit on selector unit chassis

comes to rest DC negative is connected to pin 1 of plug 13AF (fig. 4), since the "channel number" is "1," pin 13 is isolated and relay NR/2 is *not* operated.

28. Assuming that switch S1 is in some position other than "A" its rotor will be isolated from DC negative and therefore, relays CSA and CSB will be unenergized regardless of the operating condition of the springsets S2 and S3. The channel selector motor CSM has therefore a connection to the 28V DC position supply line via contact CSA2 and to

the DC negative line (via contact CSA1 and the AUTO/MAN switch in the control unit Type 7216).

29. In the assumed conditions the motor CSM will run, driving the turret assembly until the rotor of switch S1 in the drive unit comes to position 1A. The rotor of S1 is then connected to DC negative via pin 1 of plug 13AF and as soon as the springset S2 closes relays CSA and CSB are operated via relay contact NR1, S2 and S1 contact 1A.

30. Relay contact CSA1 breaks the motor supply

RESTRICTED

circuit and CSA2 short-circuits the motor armature to produce rapid braking. Contact CSB1 closes and completes the energizing circuit of the AUTO/MAN relays AMA and AMB; these relays connect the selected preset controls into the servo circuits.

31. Suppose now that channel 2A is selected at the remote control unit. Line 13 of plug 13AF will be connected to DC negative and the number relay NR thus energized. In this case, rotation of the turret will continue until switch position 2A is reached (S1).

32. The rotor of S1 remains connected to line 1 of 13AF, because the switch positions 1A and 2A are strapped together, but because relay NR is energized, the relays CSA and CSB will not be energized until springset S3 is closed. Thus the turret revolves a further 15 deg. before coming to rest, thereby bringing a fresh pair of preset controls into the operating position. Once the turret is at rest, range selection and tuning commences.

Manual operation circuits

33. Operation of the manual RANGE switch on the control unit Type 7216 enables the DC negative line to be applied to any one (selected) of the six "range" lines. These lines pass via the selector unit Type 7003 to the tuning unit Type 7015; the connections are from pins 7 to 12 on 13AA to pins 7 to 12 on 13AC, with parallel connections to the automatic range springsets RSS 1 to 6.

34. Unless the range switch in the tuning unit is in such a position that it isolates the "range" line selected, the DC negative line is taken back via this switch to "range" relay RR in the selector unit (pin 1- 13AC). In these circuit conditions the relay will operate thus completing the 28V DC circuit for the "range" motor in the tuning unit via contact RR2.

35. The range motor drives the "range" selection switches of the tuning unit until the selected contact is isolated. In this position the DC negative line to relay RR is broken, the relay releases and its contacts RR2 removes supplies to the range motor and short-circuits the motor armature to provide rapid braking.

Range and matching relays

36. In the impedance matching unit Type 7217 the DC negative connection is taken from the line selected by the tuning unit to the matching relay MR1 in the selector unit. Relay MR operates and its contacts MR1 connect the 28V DC supply to the matching motor which then drives selector switches until the selected line is isolated, thereby releasing relay MR. Contacts MR1 disconnect the motor supply and short-circuit the armature to provide rapid braking.

37. As long as the range or matching motors are running; that is with relays RR or MR operated, contacts RR1 and MR2 connect the TUNE line (plug AF, pin 14) to DC negative. This prevents

keying of the transmitter until range selection is complete (*para.* 40).

38. During MANUAL operation, the AUTO range selection springsets RSS 1 to 6 in the selector unit are prevented from influencing the selection by means of relay contact AMB1 which isolates them from the DC negative line.

39. Regardless of the state of relay CSB, relay AMB will be released during MANUAL operation, because in this condition the DC negative connection of pin 2 of plug 13AA is broken by the AUTO/MAN switch in control unit Type 7216.

Automatic range selection

40. When the AUTO/MAN switch on the control unit Type 7216 is in the AUTO position the DC negative line is disconnected from the manual range switch which is therefore ineffective.

41. Assuming the selector unit turret to be at rest, relay CSB will be operated and consequently the DC negative line connection present at pin 2 of plug 13AA (via S1) is extended by contacts CSB1 to relays AMA and AMB both of which will operate.

42. Relay contacts AMB1 provide a DC negative connection to the spring-sets RSS on the selector unit. One of the six contacts will be closed according to the position of the selected cam in the turret assembly. Therefore one of the six range lines will be connected to DC negative and range selection will proceed until this line is isolated.

Tuning relays

43. When the AUTO/MAN switch in the control unit 7216 is in the MANUAL position, the SHIFT FREQ. switch key is connected to DC negative. Operation of this key to the "L" position provides a negative connection to the "tune low" relay TL. Provided the rotors of the tuning capacitors in the aerial tuning unit are not in the "fully meshed" condition, relay TL has connection to the 28V DC positive line through the limit springsets in the tuning unit (*Chap.* 3).

44. The operation of relay TL moves the contacts TL1 to connect the DC positive line to the tuning unit whence it is fed to the tuning motor. The other terminal of the motor is returned to the "released" relay contacts TH2 and thence via the "released" relay contacts FTB1 to DC negative.

45. Since the tuning motor is a permanent magnet type, its direction of rotation is determined by the polarity of the supply connections and it is arranged that under this condition it drives the variable capacitor vanes into greater mesh.

46. This rotation continues as long as the SHIFT FREQ. switch is held in position "L," unless motion is arrested by the rotors reaching full mesh, in which case the striker on one of the capacitor rotors closes a "limit" springset. The operation of springset causes the LIMIT lamp in the control unit

RESTRICTED

to glow and immediately afterwards a second springset is operated, thus breaking the DC positive connection to relay TL.

47. When relay TL releases, contacts TL1, in conjunction with contacts TH2, short-circuit the armature of the tuning motor, providing rapid braking.

48. If the SHIFT FREQ. key is moved to the position "H," the "tune high" relay TH is operated in a similar manner to that described for relay TL. The contacts TH2 connect the DC positive line to the tuning motor, the negative side of the motor is returned to DC negative via pin 19 of 13AC and the "released" contacts TL1 and FTB1.

49. The polarity of the tuning motor connection is, therefore opposite to that for the circuit conditions when relay TL is operated and the direction of rotation will be such as to drive the variable capacitor in the direction of decreasing mesh. The rotation of the tuning motor in this direction will continue until either the SHIFT FREQ. switch is released or the variable capacitor reaches its fully "unmeshed" condition.

50. In the second event, the striker referred to above (*para. 46*) first closes the springset which causes the LIMIT lamp to glow, and then opens the springset which breaks the DC positive connection to relay TH. The tuning motor is thus short-circuited to provide rapid braking when both TL1 and TH2 are in the "released" condition.

51. Since relay AMA is "released" during MANUAL operation, contacts TH1, TL2 and BR1 are isolated from DC negative and have no effect. During COARSE tuning however, the fine tuning relay FTA is also "released," and a DC negative connection exists via contacts FTA2 and AMA2 to the meter shunt relay MS and via pin 15 of plug 13AF to the "low power" circuits of the transmitter (through control unit Type 4190).

52. Thus during COARSE tuning, the transmitter

can be operated only in the "lower power" condition and the shunts of the RF monitoring meters are selected by relay MS to give an adequate reading for this low power condition.

53. Once the operator is satisfied that the tuned circuit is near resonance, he can switch to FINE tuning. The fine tuning relay FTA will operate, thus releasing relay MS and the "low power" relay in the transmitter circuits so that final tuning adjustments can be made under full power conditions.

Monitoring circuit

54. The potentiometer RV1 in the tuning unit forms part of the Wheatstone bridge servo system used for automatic tuning. During MANUAL operation RV1 is left in circuit and a connection is brought from its wiper via a 27K ohm resistor R2 in the selector unit to pin 15 of plug UB.

55. A monitoring meter in the control unit is connected to the wiper of RV1 by pressing the button of the SERVO CHECK switch. The meter is so connected as to measure the P.D. between the wiper of RV1 and DC negative. Since this P.D. is dependent on the position of the wiper, it can be used as an indication of the position of the capacitor rotors (*para. 67*).

56. When the AUTO/MAN switch on the control unit Type 7216 is in the AUTO position, there is no DC negative connection to the poles of the SHIFT FREQ. key unless the FINE/COARSE switch is in the FINE position. Under conditions of coarse tuning, therefore, the SHIFT FREQ. key is inoperative.

57. Assuming the turret to be at rest, relays CSA and CSB will be operated and consequently relays AMA and AMB are energized via CSB1 and the AUTO/MAN switch. The fine tuning relays FTA and FTB are both "released" (since the FINE/COARSE switch is in the COARSE position), and therefore a DC negative connection is made via contacts FTA2 and AMA2 to the moving pole BR1 of the centre-stable relay BR.

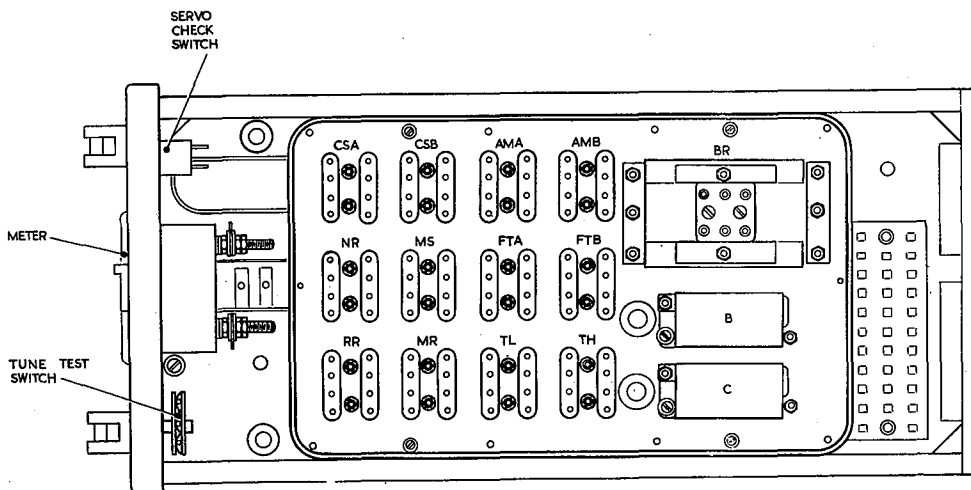

Fig. 3. Selector unit underside of chassis

RESTRICTED

Centre-stable relay and Wheatstone servo

- 58.** Since relay AMB is operated and relay FTB released, the coil of the centre-stable relay BR is connected on one side via brush B1 to the wiper assembly of the turret in the selector unit and on the other side direct to the wiper of the tuning unit potentiometer. This potentiometer and the associated potentiometer RV1 adjacent to the selector unit turret are connected directly across the 28V DC supply so as to form a Wheatstone bridge arrangement with the centre-stable relay occupying "galvanometer" position.
- 59.** The turret assembly carries 24 independently adjustable wipers (one per channel) and whichever is in contact with potentiometer RV1 can be adjusted by rotating its lead screw through an access hole in the selector unit front panel.
- 60.** The potential at terminal "a" of relay BR thus depends on the point at which the wiper in use makes contact with potentiometer RV1 adjacent to the selector unit turret. While that of terminal "b" is that of the wiper of the potentiometer ganged to the variable capacitor assembly in the tuning unit.
- 61.** Any difference of potential between these two points will give rise to a current through the coils of relay BR and since this is a centre-stable relay, the direction of movement of its moving contact will depend on the direction of the current in the coil. The relay may, in fact, be regarded as a "centre-zero" galvanometer, with its scale replaced by two fixed contacts. The sensitivity is similar to that of a galvanometer, a current of about 75 μ A being sufficient to operate it.
- 62.** The connections of relay BR are so arranged that it closes on the contact marked "H" when the potential of coil terminal "a" is higher than that of terminal "b" and on terminal "L" is the reverse of the case.
- 63.** To prevent possible inductive surges from burning the delicate contacts BR1, spark quenching arrangements each consisting of a rectifier and resistance (MR1, R8; MR2, R9) are connected across the coils of relays TL and TH, respectively.
- 64.** The functioning of the AUTO tuning arrangements can be most easily understood by a description of the "setting up" which follows in *para.* 65 to 73.
- 65.** On the front panel of the selector unit there is a SERVO CHECK push button PB1 (*fig.* 1). Pressure on this causes the meter (also on the front panel) to be connected via the 27K resistor R1 to brush B1 which is in contact with the turret.
- 66.** As in the case of the control unit Type 7216, the meter is a 1 mA type and the arrangement forms a voltmeter with a f.s.d. of about 27 volts connected in this case so as to read the P.D. between the turret frame and DC negative. This potential is determined by the position of the wiper in use on the associated resistor RV1.
- 67.** Thus by pressing the SERVO CHECK button, the operator can check the capacitor position and also verify that the SHIFT FREQ. key is operating correctly. When the key is moved to "H" the meter reading should increase whereas movement to "L" should cause a reduction to take place.
- 68.** It should be noted that the scale calibration in degrees (0-180) is not intended to be exact and no attempt has been made to compensate for supply variations. However, it is accurate enough to be used in conjunction with a calibration chart to indicate at what point in the capacitor travel the operator should begin to explore for resonance at any given frequency.
- 69.** Assume that the system is at rest with the variable capacitor set at 60 deg., and it is now desired to set the capacitor to 110 deg. With the SERVO CHECK button pressed, the operator moves the wiper in use by means of its lead-screw (turning clockwise to increase the setting) until the meter reads 110 deg.
- 70.** The potential of terminal "a" of relay BR is now higher than that of terminal "b" and BR1 therefore operates on its "H" contact, causing relay TH to be operated from the DC negative line via contact AMA2 and FTA2 (*fig.* 4). The tuning motor TM starts to drive the variable capacitor in the direction of *frequency increasing* (towards 180 deg.).
- 71.** The potential at terminal "b" of relay BR rises until the point is reached (at a capacitor setting of very nearly 110 deg.) when the P.D. is insufficient to hold the contacts closed, so that they open and release relay TH.
- 72.** Although braking is applied by short-circuiting the armature of tuning motor, the inertia of the system is generally enough to carry the capacitor past the desired position. Consequently, the potential at terminal "b" of relay BR now becomes higher than that at terminal "a" to an extent sufficient to cause contact BR1 to close on its "L" contact and thus operate relay TL.
- 73.** This causes the tuning motor to run in the opposite direction and returns the system towards the desired position once more. Again, although relay BR will release, and thus release relay TL slightly before the correct position is reached, it would be possible for inertia to carry the system far enough beyond the correct position to operate relay TH once more.
- 74.** When it is required to adjust any particular channel to a lower frequency than its existing setting, the lead screw is turned counter-clockwise, thereby causing the wiper in use to travel towards the low potential end of the selector unit resistor RV1.

RESTRICTED

75. Thus the potential of terminal "a" of relay BR falls below that of terminal "b" contact BR1 closes on its "L" contact, and relay TL is operated. Tuning motor TM consequently starts to drive the variable capacitor into close mesh and the ganged wiper of the tuning unit potentiometer RV1 travels towards its low potential end until the P.D. across relay BR disappears, opening the "L" contact and releasing relay.

76. As in the previous case an initial overshoot may occur but hunting is prevented by an "anti-hunt" device on the aerial tuning unit (*Chap. 3*). Thus the position taken up by the capacitor during AUTO tuning is governed entirely by the point of contact of the turret wiper which is brought into the operating position.

77. One wiper is provided for each of the 24 channels and the wiper associated with the selected channel in the transmitter-receiver system is brought into mesh by rotation of the turret under control of the channel selection circuits.

78. During the setting up operation it is essential that the operator should be able to key the transmitter and observe the approach of the system to resonance. The facility is provided by the key switch on the selector unit front panel which is moved to the TUNE position. This breaks the DC negative connection to the TUNE line which is otherwise made via FTA, AMA2, TL2 or TH1 and S4a, thus enabling the key circuits to operate. At the same time the transmitter power is slightly reduced to prevent overloading whilst tuning is taking place.

Fine tuning relays

79. The fine tuning arrangement during either AUTO or MANUAL operation is designed to permit fine adjustments to tuning whilst the transmitter is being keyed at full power. The fine tuning condition is brought about in either case by the operation of the two FINE TUNE relays FTA and FTB.

80. During AUTO operation the operator may suspect for some reason that the aerial system is slightly detuned (this condition will be evidenced by a "lower-than-normal" reading of the monitoring meters). The operator therefore moves the control switch on control unit Type 7216 to the FINE position and thus provides a DC negative connection to both poles of the SHIFT FREQ. key.

81. Immediately the SHIFT FREQ. key is operated, it connects the DC negative line to operate relays FTA and FTB. During AUTO operation relay AMA is operated and once the FINE TUNING relays are operated the circuit is held by the DC negative connection provided via FTA1, AMA1 and the FINE/COARSE switch.

82. Relay contact FTA2 removes the DC negative connection previously existing via FTA2 and AMA2 (AMA2 is "operated") to contacts BR1, TH1 and TL2. Contact BR1, therefore, can no longer control the tuning relays TL and TH but these can be operated by means of the SHIFT FREQ. key. It

is thus possible for the operator, by movement of the SHIFT FREQ. key to positions "L" or "H" to energize relays TL or TH, respectively, and so run the tuning motor in either direction.

83. Because contacts TL2 and TH1 have been isolated from DC negative by FTA2, they can no longer operate the TUNE circuit and thus interrupt keying. The operator is therefore able to key the transmitter continuously and observe the effect of his adjustments by means of the monitoring arrangements.

84. Relay FTB is arranged to reduce the speed of motor TM during FINE tuning by means of contact FTB1 which introduces the 68-ohm resistor R7 into the motor negative line. Contact FTB2 open-circuits the centre-stable relay BR to protect its coil from the possibility of large steady currents which could arise if the required re-tuning unbalanced the Wheatstone bridge circuit to any great extent.

85. As a precaution against the possibility of the AUTO tuning system remaining inoperative on the selection of a fresh channel, it is arranged that relay AMA is released during channel selection. The release contact of AMA1 releases the fine tuning relays FTA and FTB, thus returning the system to normal. This precaution is taken against the possibility of the operator failing to return the FINE/COARSE switch to the COARSE position. The relays FTA and FTB will remain released until operated again by further use of the SHIFT FREQ. key.

86. The circuit differences between AUTO and MANUAL fine tuning result from the fact that relay AMA is *not* operated for MANUAL operation. With S1 in the MANUAL position, relays FTA and FTB operate when the FINE/COARSE is switched to FINE and remain operated until it is returned to COARSE.

87. Contacts BR1, TL2 and TH1 are already isolated by contact AMA2, which is released, but FTA2 is now employed to remove the DC negative connection from the LOW POWER line (plug 13AF, pin 15) so that FULL POWER operation is possible. Direct control of tuning at *low speed* is, therefore, again available at the SHIFT FREQ. switch key and continuous monitoring can be carried out with the transmitter keyed at full power.

Keying (tune) interlock

88. To protect the transmitter and to avoid arcing of switch and relay contacts, control circuits are provided to prevent accidental keying of the transmitter whilst channel changing operations are in progress. This protection is provided by the TUNE line of the installation which enters the aerial system at pin 14 of plug 13AF on the selector unit.

89. A connection to DC negative at any point on this line operates protective circuits in the transmitter installation which prevent keying of the transmitter. Such a connection is provided by contacts CSB1 of channel selection relay CSB during channel selection and by contacts RR1 of

range relay RR and MR2 of matching relay MR during range selection.

90. During AUTO operation, the TUNE line is also connected to DC negative via FTA2, AMA2, TH1 or TL2 and switch S4a in either the OPERATE or TEST positions.

91. Thus under normal operating conditions the transmitter cannot be keyed until channel selection, range selection and tuning are complete. In order to simplify the process of adjusting the aerial system to resonance, however, provision has been made for the transmitter to be keyed while *tuning only* is taking place, providing that adequate protection of the transmitter has been afforded in some other way. The special conditions are described under the headings which follow (*para.* 92 to 96).

MANUAL operation

92. In conditions for MANUAL operation, the aerial system channel selection cannot function because the AUTO/MAN switch on control unit Type 7216 has removed the DC negative connection from pin 1 of 13AA on the selector unit. Contact CSB1 is rendered inoperative by the same switch which disconnects DC negative from pin 2 of 13AA.

93. During COARSE tuning; i.e. whilst the operator is searching rapidly through the capacitor sweep for the required setting; the LOW POWER line (pin 15 of 13AF) is connected to DC negative via FTA2 and AMA2 and the transmitter is caused to operate at LOW POWER. This gives adequate protection of the transmitter and contacts TH1 and TL2 can be safely isolated by AMA2 to permit the transmitter to be keyed continuously whilst searching.

94. Once the required setting has been located, the operator moves the FINE/COARSE switch to the FINE position for accurate adjustment. Relay FTA is thus operated and its contact FTA2 removes the DC negative connection from the LOW POWER line. The transmitter can then be keyed at full power. Relay AMA remains released and contacts TH1 and TL2 therefore do not operate the protective arrangements.

AUTO operation

95. If during the AUTO operation it is required to make re-adjustments of tuning, the facility is provided by the FINE position of the FINE/COARSE switch in conjunction with the SHIFT FREQ. key. In these conditions, although relay AMA is operated, contacts TH1 and TL2 are isolated because FTA2 is operated and the re-adjustments can thus be made with the transmitter operating at full power.

Setting up

96. During the setting up of channels, the TUNE/TEST switch S4a is arranged to isolate contacts TH1 and TL2 from the protective circuits when the switch is in the TUNE position. This enables the preset controls to be set up with the transmitter keyed continuously; protection being afforded in this case by the introduction of resistance in the screen feed of the transmitter power amplifiers.

Test lamp circuit

97. The TUNE lamp in the selector unit remains illuminated whilst the protective circuits are preventing transmitter keying. It is returned to the 19V positive line at pin 22 of plug 13AF (*fig.* 4) and is thus the only component in the selector unit which is not operated from the 28V supply.

98. This arrangement is necessary because the whole of the protective system in the transmitter installation operates from the 19V supply and the use of the 28V supply for the TUNE lamp in the selector unit would have produced an undesirable connection between the two supply voltages.

TUNE operation

99. The TUNE/TEST key S4 is provided to facilitate the setting up operation. In its normal OPERATE position, S4b connects the RF monitoring circuits to the meter in the control unit Type 7216. In either the TUNE or TEST positions the RF monitoring circuits are connected to the meter of the selector unit, so that the entire operation of setting up may be carried out from this unit.

100. The TUNE position of S4 is arranged to key the transmitter under conditions of slightly reduced power output. This protects the transmitter against possible overloading.

101. Contacts TH1 and TL2 do not operate the TUNE line under this condition, because they are isolated by S4a. Switch section S4c at the same time provides a DC negative connection for the SAFE line (pin 20 of 13AF). This enters the control unit Type 4190 (*Sect.* 1, *Chap.* 3) at pin 20 of socket 1AF and operates relay 1RL7.

102. As a consequence of the above circuit conditions the transmitter will be keyed at *slightly reduced* power as long as switch S4 is held in the TUNE position.

Low power operation and RF monitoring

103. Facilities are provided in the transmitter installation for operation at very approximately $\frac{1}{4}$ th power for short range communication. This condition is brought about under normal conditions by "earthing" the LOW POWER line at pin 6 of the intercom. socket 3SK5 on the power and radio unit (*Sect.* 1).

RESTRICTED

Chapter 6

TUNING UNIT (AERIAL) TYPE 7016

LIST OF CONTENTS

	Para.		Para.
Introduction	1	Desiccator	32
Construction	5	Antivibration mounting	33
Wheatstone bridge servo system	13	Circuit description	34
Drive unit, mechanical, Type 9251	14	Range switching	35
Tuning unit Type 9252	18	Range repeater switch	40
Capacitor unit Type 9309	19	Capacitor tuning... ..	41
Wheatstone servo potentiometer RVI	22	Limit switches	43
Capacitor unit Type 9310	24	Pressure-operated switches	46
Pressurized canister assembly	25	Negative line and earth connection	47

LIST OF ILLUSTRATIONS

	Fig.		Fig.
Tuning unit (aerial) Type 7016 on mounting tray	1	Exploded view of aerial tuning unit	5
Mechanical drive unit and capacitors (1)	2	Tuning unit and mounting Type 9056	6
Mechanical drive unit and capacitors (2)	3	ARI.5874—Tuning unit (aerial) Type 7016—circuit	7
Drive unit, mechanical, Type 9251	4		

Introduction

1. Tuning unit Type 7016 is similar in construction to tuning unit Type 7015 (*Chap. 3*) but is designed to give greater maximum capacitance than the latter. The unit consists mainly of an electro-mechanical drive unit driving a 3-section variable capacitor in association with a fixed capacitor switched in three sections from the same device. The fixed capacitor has been added because it would not be practicable to accommodate a fully-variable capacitor of the required value in the space available. A general view of the tuning unit with its mounting tray is given in fig. 1.

2. Since the tuning unit has to be mounted adjacent to the cavity in the airframe, it will be located outside the pressure cabin and therefore subjected to extreme changes in atmospheric pressure. To obviate the effect of reduced pressure under working conditions at high altitudes the capacitor (and the drive unit) are completely enclosed in a pressurized canister. This canister is somewhat longer than that of the tuning unit Type 7015.

3. As with the tuning unit Type 7015, the canister is pressurized in service to about $5\frac{1}{2}$ lb. per sq. in. above atmospheric pressure. Two pressure-

operated switches are fitted and one of these operates the SAFE lamp on the control unit Type 7216. The SAFE lamp is extinguished if the pressure in the canister falls below 16 lb. per sq. in. absolute, thus indicating the necessity of re-pressurization and/or leakage check.

4. The second pressure-operated switch automatically switches the transmitter to the "low power" condition when, as a result of further decrease of pressure within the unit, operation at full power would entail a risk of RF breakdown.

Note . . .

Although voltages encountered in the "cavity" system are lower, maximum values being about 2.5 kV peak, the capacitor spacings are smaller, and unsuitable to withstand this voltage if the canister pressure falls far below atmospheric pressure.

Construction

5. The two main components of the tuning unit (aerial) Type 7016 (10D/19833) are designated as follows:—

- (1) Drive unit, mechanical Type 9251 (10AR/2633).
- (2) Tuning unit Type 9252 (10D/22508).

RESTRICTED

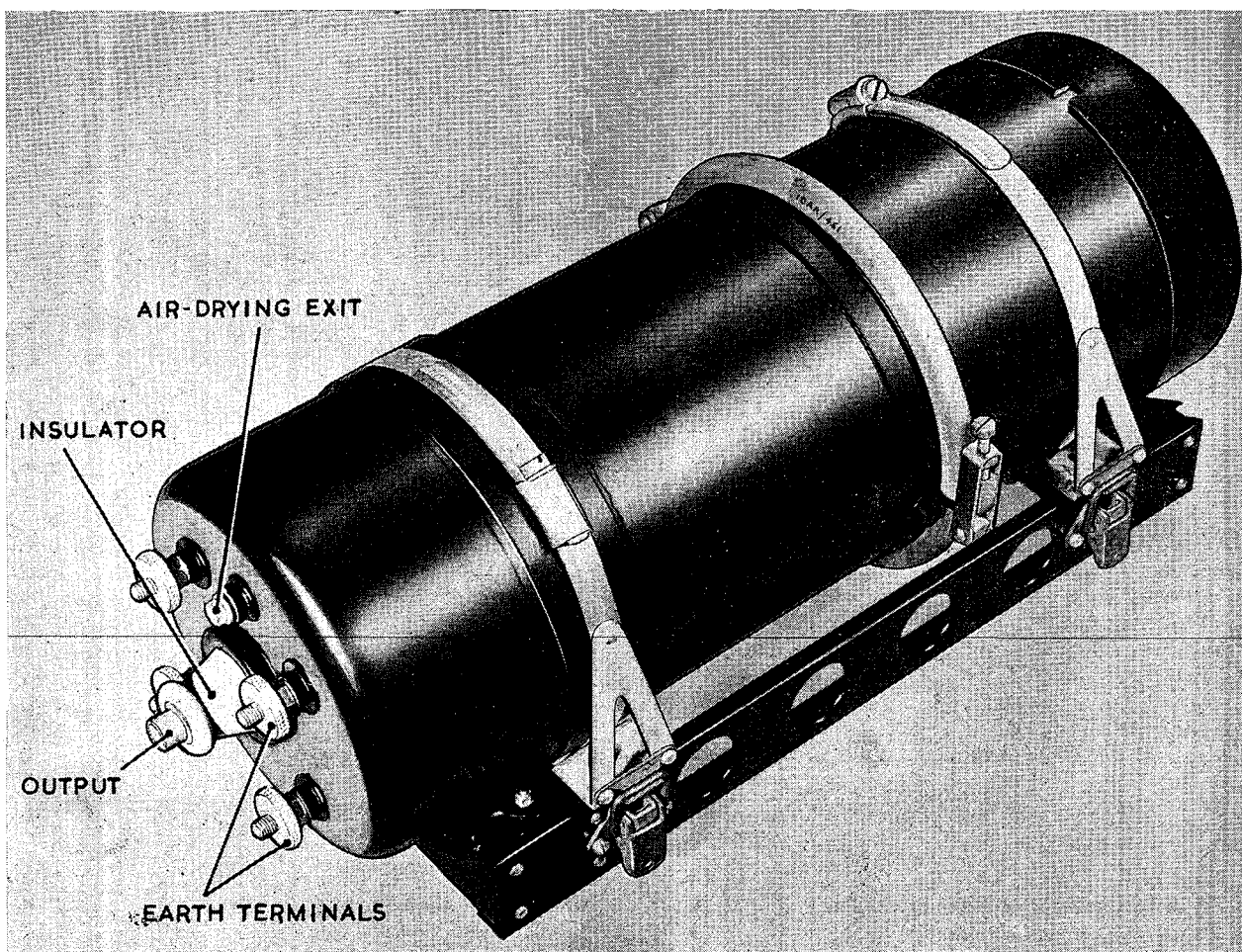

Fig. 1. Tuning unit (aerial) Type 7016 on mounting tray

6. Other items include two cylindrical covers upon which are mounted the plugs and sockets for electrical connection to the units inside the pressurized canister. These are described in para. 25. The overall dimensions of the tuning unit are: length $20\frac{1}{2}$ in., diameter $7\frac{3}{4}$ in.

7. The pressurized canister is fitted with a Schrader valve (valve, tank, 10S/1770) to enable it to be filled with *dry* air or nitrogen at about $5\frac{1}{2}$ lb. sq. in. above normal atmospheric pressure.

Note . . .

If the tuning unit is opened for servicing, it is most important that it should be oven-dried and scavenged by a flow of dry air before re-sealing and pressurizing.

8. Electrically, the servo systems incorporated in tuning unit Type 7016 are identical with those in tuning unit Type 7015, but there are variations in mechanical layout and switching resulting from the different capacitor arrangement.

9. All the DC components and circuit wiring are arranged at one end of the variable capacitor (fig. 2) and the 3-section fixed air-spaced capacitor is secured at the other. The range switching device is fitted between the fixed capacitor and the vari-

able capacitor. It is driven by a shaft which runs the full length of the variable capacitor.

10. The operating cam of the range switching device is of nylon-loaded bakelite ("Tufnol" in early models) and is arranged to open and close, in certain order, a group of five silver-tipped springsets situated between the cam and the fixed capacitor assembly. These springsets connect the appropriate capacitor sections *in parallel* to a central conductor, which is in turn connected by a heavy duty plug and socket to the RF terminal on the canister.

11. The heavy duty socket is mounted on the fixed capacitor assembly and the plug is carried on an extension of the RF terminal which passes through a central hole in the fixed capacitor plates (fig. 3). The smallest section of the variable capacitor is permanently connected to the central conductor and is the only section in use on range 1. The order of operation of the springsets is such that the following range switching sequence takes place:—

- Range 1. Smallest section of variable capacitor.
- Range 2. Intermediate section of variable capacitor added to smallest section.

RESTRICTED

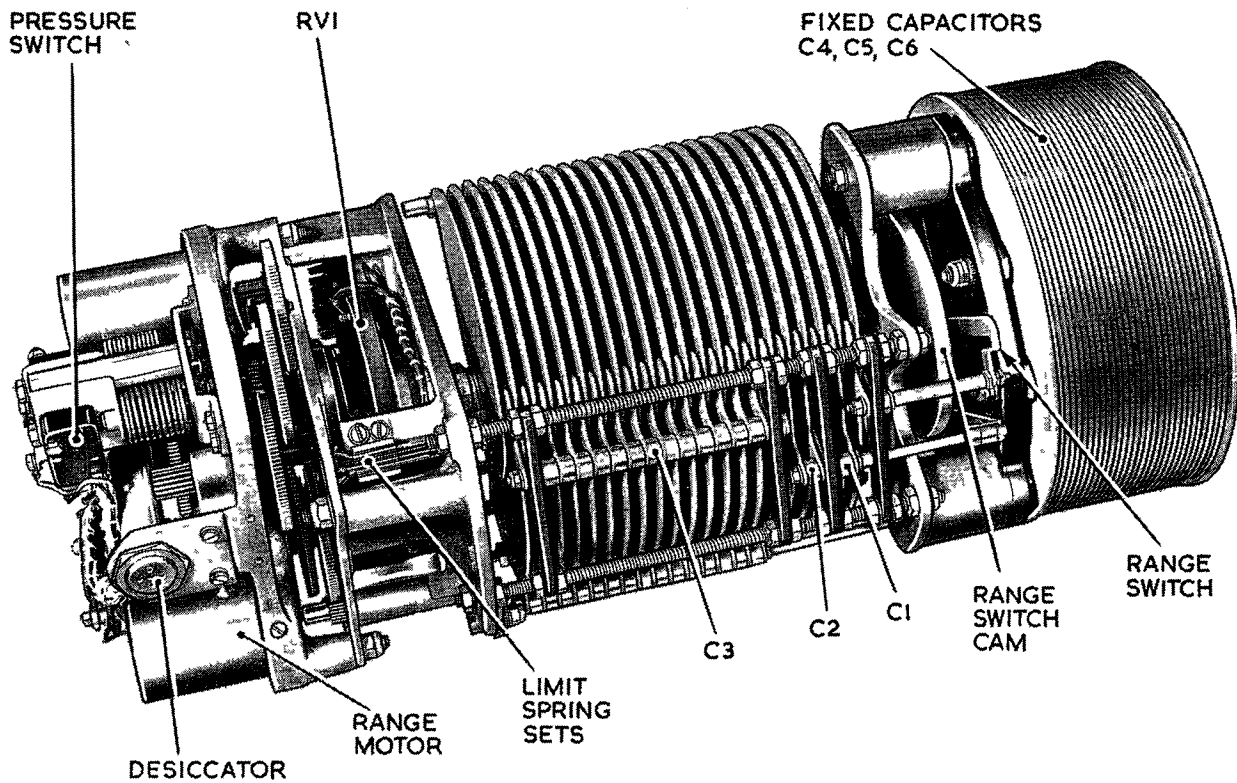

Fig. 2. Mechanical drive unit and capacitors (1)

- Range 3. Largest section of variable capacitor added to the other two.
- Range 4. First section of fixed capacitor added to full variable.
- Range 5. Second section of fixed capacitor added to first section plus full variable.
- Range 6. Third section of fixed capacitor added to first and second section plus full variable.

12. Remote control of the motor-driven range switch in the tuning unit (and the matching switch in the impedance matching unit) is provided by a simple line-finder circuit from the aerial selector unit Type 7003. Continuous tuning over each range can be manually controlled and the variable capacitor driven in either direction by switching at the remote control unit.

Wheatstone bridge servo system

13. Coupled to the rotor shaft of the variable capacitor is the wiper of a toroidal potentiometer which forms part of the Wheatstone bridge servo system used for automatic tuning (*para.* 22). The arm of the bridge is coupled to a similar potentiometer in the aerial selector unit Type 7003 and the bridge is balanced when the aerial system is in resonance on the chosen frequency channel.

Drive unit, mechanical, Type 9251

14. Drive unit, mechanical, Type 9251 (10AR/2633) consists of two motor units driving gear train systems which in turn drive the rotor of the variable capacitor and the cam-operated switch selector of the sections of the fixed and variable capacitors (*fig.* 4).

15. The motors (X1 and X2) are versions of the motor electric PM1A (5UD/5669) modified to fit 22-tooth pinion $\frac{1}{8}$ in. P.C.D. They are described as motor units, Type 7221 (10K/18114).

16. Geared to the drive is a switch unit Type 9260 (10F/18713). This is a 2-bank, 2-pole, 6-way range switch (SWA) fitted with a 44-tooth pinion. The complete switch is mounted on a Tufnol strip secured to two pillars on the casting. The switch has two wafers (10F/18712) and 10F/18711) each being a single-pole 6-way switch (*fig.* 4).

17. The remainder of the drive unit includes the following:—

- (1) Plugs unit (Z.562504). This is an 18-way plug (PL3) constructed from nylon-filled bakelite. It provides connection of the electrical connections from the mechanical drive unit to the tuning unit Type 9252 (10D/22508).

RESTRICTED

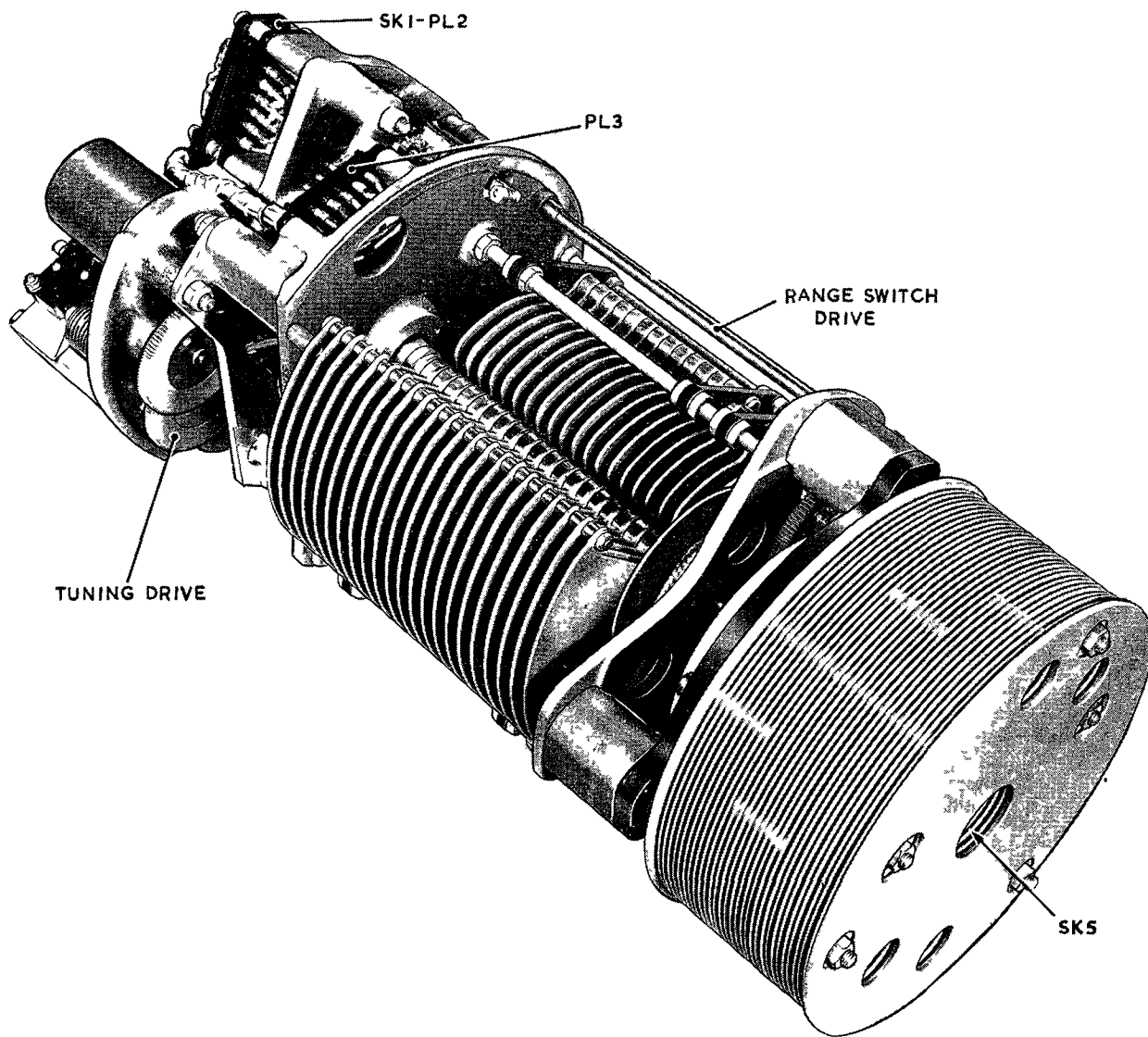

Fig. 3. Mechanical drive unit and capacitors (2)

- (2) Slow motion drive, Type 96 (10AR/2636). This is a 9 to 1 reduction drive over 7 degrees with 80-tooth pinion.
- (3) Gear assembly Type 9261. (10AR/2637). This is an assembly of 22-tooth and 29-tooth stainless steel gears and a Tufnol 96-tooth gear mounted on an Oilite bush.
- (4) Pressure-operated switches. Two pressure-operated switches are mounted as one assembly consisting of two bellows and two switches sensitive (Z,510080). The complete assembly with overall dimensions of $1\frac{1}{2}$ in. \times $1\frac{1}{2}$ in. \times 2 in. is known as switch unit Type 7223 (10F/17562) and is mounted on the casting at the mechanical drive unit end. The operating pressures are approximately 20 lb. and 11 lb. sq. in. absolute.

Tuning unit Type 9252

18. The tuning unit Type 9252 (10D/22508) consists of the following items:—

- (1) Capacitor unit Type 9309 (variable).
- (2) Capacitor unit Type 9310 (fixed).
- (3) Contacts Type 442 ("cam-operated" switch device).

Capacitor unit Type 9309

19. This is a variable capacitor assembly (10C/22677) with a three-section stator C1, C2 and C3, it includes the following items:—

- (1) Conductor assembly (10AR/2644). This is a flexible braid (or bonding pigtail) connecting the moving shaft of the capacitor to the frame of the tuning unit.

RESTRICTED

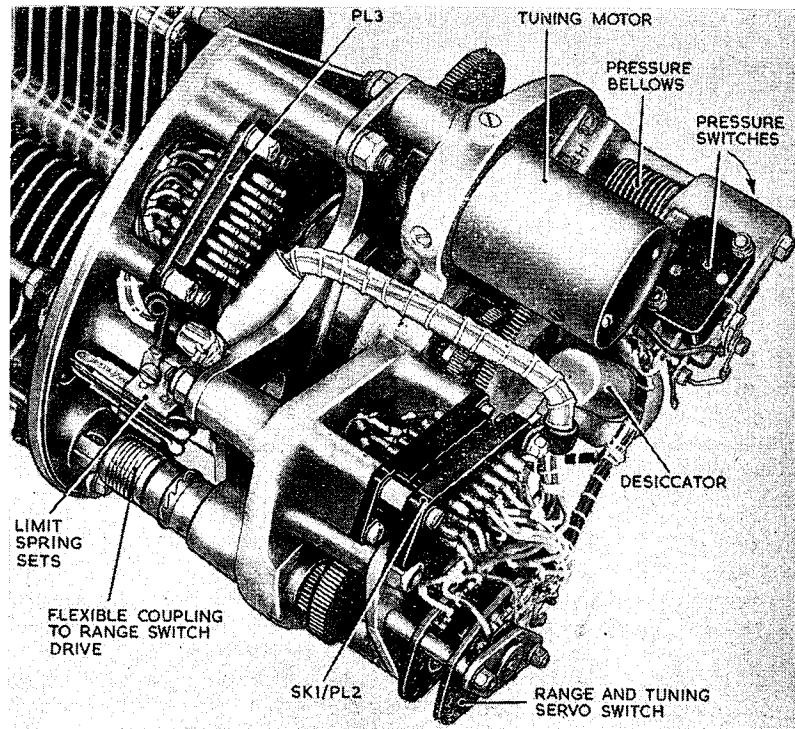

Fig. 4. Drive unit, mechanical, Type 9251

- (2) Gear wheel Type 74 (10AR/2643). This is a 116-tooth Tufnol gear wheel connecting the switch motor drive to the cam-operated switching device (contacts Type 442).
 - (3) Plugs unitor, 25-pole (Z.562505). This is the 25-way plug PL2 which connects the tuning unit to the canister seals TB1, TB2 and TB3. (fig. 5).
 - (4) Resistor Type 10811 (10W/20029). This is the 500-ohm potentiometer RV1. It is wirewound on a moulded former and mounted at the drive unit end of the tuning unit (fig. 2).
 - (5) Contact Type 441 (10AD/365). This is the wiper for potentiometer RV1. It is a plated brass contact set in polythene. The wiper rotates with the shaft of the capacitor.
 - (6) Socket unitor (Z.562509). This is the 18-way socket SK2 connecting the mechanical drive unit to the tuning unit plug PL2.
20. A "limit" switching device is provided on the variable capacitor. This is arranged to operate springsets which halt the drive and light a warning lamp on the control unit Type 7216 when the rotor reaches either limit of its travel.

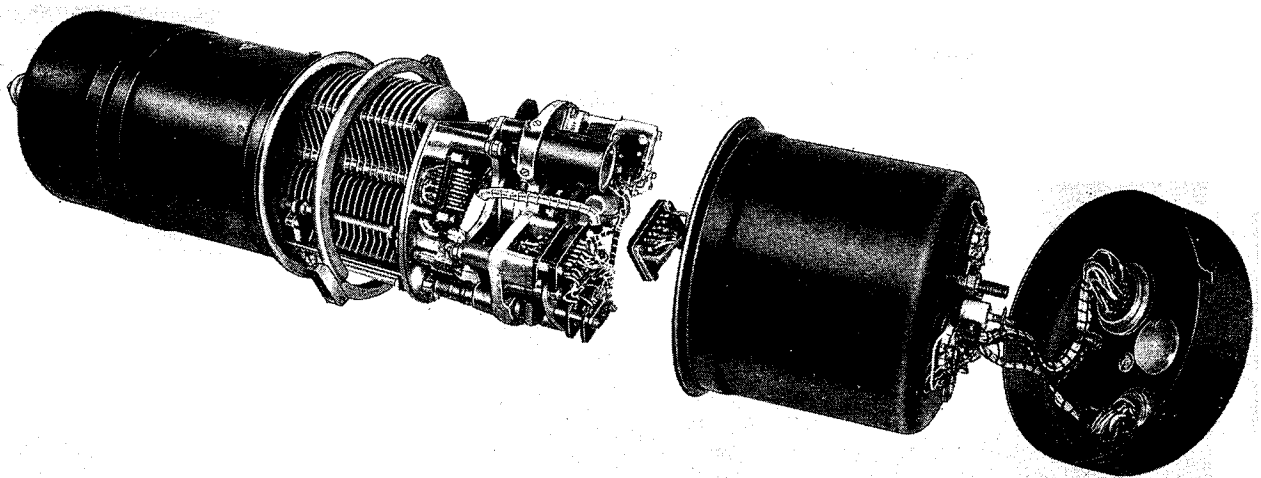

Fig. 5. Exploded view of aerial tuning unit

RESTRICTED

21. The springsets are listed as single-pole, changeover, light duty. The "left-hand" set are spring sets Type 115 (10F/17563) and the "right-hand" set are spring sets Type 116 (10F/17564). Each set is operated by an insulated "stop" on the end vane of the moving section of the variable capacitor.

Wheatstone servo potentiometer RV1

22. The potentiometer associated with the Wheatstone bridge servo system is mounted at that end of the variable capacitor nearest the mechanical drive unit.

23. The resistor is a wirewound toroidal type on a moulded square section former with a 200 deg. arc of winding. The value of the resistor is 500 ohms (5 per cent.), 3 watts. The contact is of silver-plated brass strip clamped on to the end of the variable capacitor driving shaft.

Capacitor unit Type 9310

24. This is a fixed capacitor (10C/22678) with three sections C4, C5 and C6 (*fig. 2*). The capacitor is mounted on a polythene base to which are connected five single contacts of the cam-driven switch SWF designated as follows:—

(1) Contacts Type 422. This is a nylon-braided bakelite plate with five contact points mounted on it. The complete assembly includes the following:—

(a) Contacts Type 443. There are three of these each of bronze silver-plated strip $1\frac{7}{8}$ in. \times $\frac{1}{4}$ in. with a fixing hole at one end.

(b) Contact Type 444 (10AD/369). There is one of these of length $2\frac{1}{8} \times \frac{1}{4}$ in. with fixing hole at one end.

(c) Contact Type 445 (10AD/370). There is one of these of length $2\frac{1}{2} \times \frac{1}{4}$ in. with fixing hole at one end.

(2) The items under (1) together with the moulded nylon-braided bakelite plate make up a cam-operated switching device for the selection of the fixed and variable sections of the two capacitors. The sequence of switching is given in the circuit description.

Pressurized canister assembly

25. The complete cover assembly consists of:—

(1) Cover Type 1086 (10AP/318). Cylindrical cover of length $10\frac{1}{2}$ in. \times $6\frac{1}{8}$ in. diameter with porcelain insulator. The cover includes:—

(a) Plug Type 882 (10H/19897) PL4 40-amp output (from tuning unit).

(b) Washer, sealing Type 69 (10SC/348). This is a locking star washer moulded in synthetic rubber and is used with the pressurizing plug with a screw fit at the end of the cover (*fig. 1*).

(2) Cover fitted (10AP/317). This is an assembly of two fitted covers (*fig. 5*) including:—

(a) 25-pole plug PL1 (Z.560200).

(b) 12-pole socket SK3 (Z.560330).

(c) Socket, Unitor, 25-way SK1 (Z.562510).

(d) Valve, tank. Schrader connection (10AS/1770) (including cover Type 904—10AP/904).

26. The pressurized canister is made from 20 SWG mild steel, open at one end and with three seals incorporating electrical connections and the Schrader valve at the other (valve, air, 10AS/1771).

27. When the variable capacitor and its drive unit are secured in the fitted cover (10AP/317), the 25-way socket wired to the seals in the cover is mated to the 25-way plug on the mechanical drive unit.

28. The circular rubber gasket Type 443 (10AL/305) is then placed between the two cover sections and the canister made airtight by fitting two clamps Type 409 (10AR/451).

29. These clamps are made from 18 SWG mild steel bent into "V" sections. They are described as 3.5 in. internal radius circular half clamps with latch screw at one end and block at the other. When the clamps are secured the airtight cover can be pressurized via the Schrader valve.

30. To facilitate the use of conventional connectors with the sealed container, two multipole plugs are wired to the sealed connections in the cover. The two covers are held together by the hexagonal nut and screw fitting shown in *fig. 6*.

31. The completely sealed unit is shown in *fig. 1*. All the electrical connections with the exception of the aerial output will be made to the two multipole plugs mounted on the cover. The aerial output is via the plug connection through the porcelain insulator protruding from the cover Type 1086.

Desiccator

32. A desiccator Type 107 (10AQ/572) is fitted in a bracket on the mechanical drive unit. It is a silica gel, non-indicating type and can only be removed when the tuning unit is taken from the canister.

Antivibration mounting

33. The aerial tuning unit is not mounted in the standard racking but will be fixed in close proximity to the impedance matching unit and the cavity in the wing root (*fig. 4*). The special rectangular mounting tray is shown in *fig. 6*. It has four anti-vibration mountings and quick release brackets for the aerial tuning unit. The complete mounting is designated mounting Type 9056 (10AJ/249).

Circuit Description

34. A complete circuit of the aerial tuning unit is

RESTRICTED

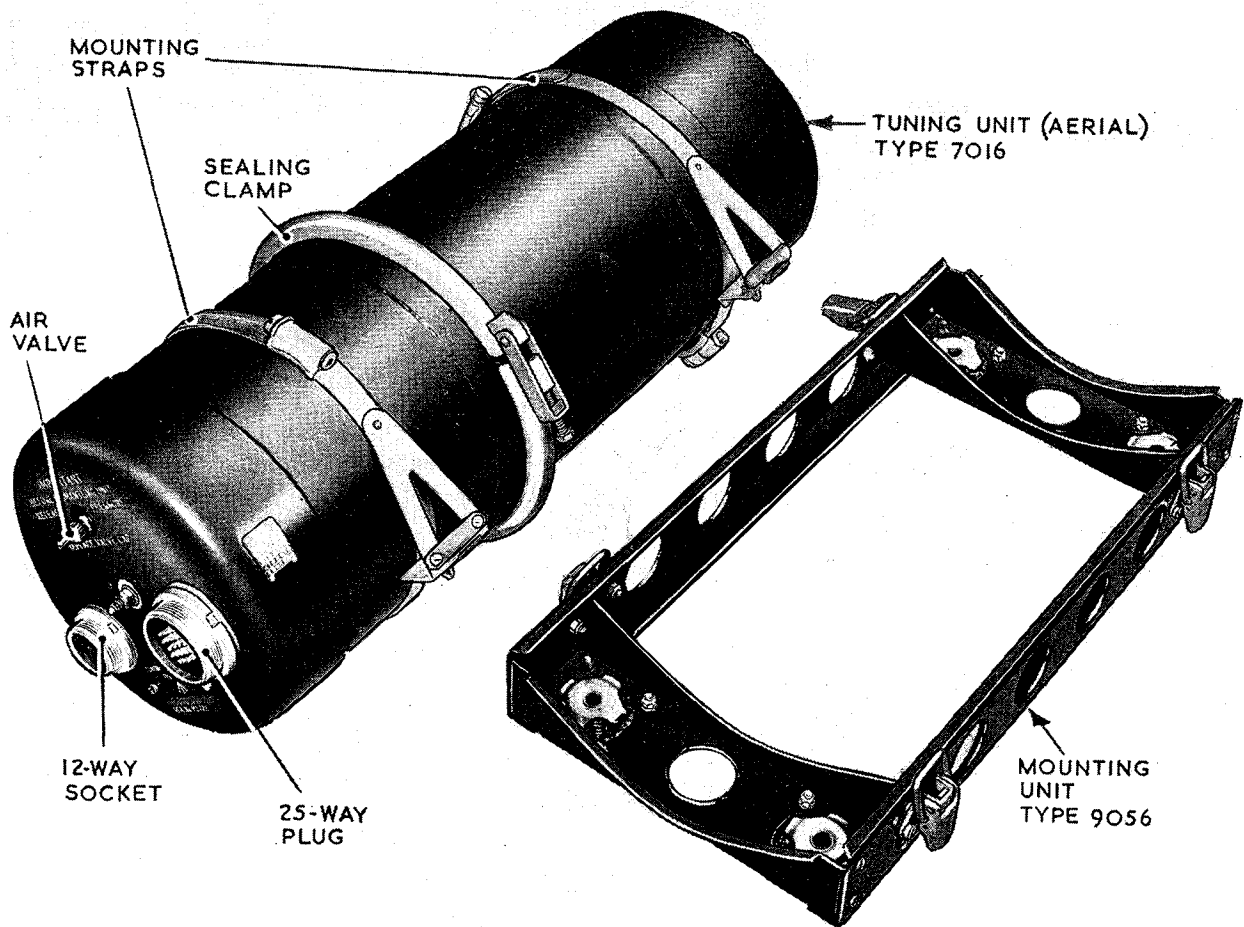

Fig. 6. Tuning unit and mounting Type 9056

given in fig. 7. A drawing of the cavity and the connection to the tuning unit and the impedance matching unit appears in Chap. 7.

Range switching

35. The range switch SWA is connected to the manual and automatic range switching circuits in the control unit Type 7216 and selector unit Type 7003 via the plug and socket AB. A seventh connection to the range relay in the selector unit is via pole A of AB.

36. For any position of the range switch SWA, other than the position selected at remote control, the range relay in the selector unit Type 7003 will be energized and the range motor in the tuning unit will run until the selected position is reached. The range motor supply is from pole B of AB and the earth return bonded to the frame (pin C or 25-way plug AB).

37. When the range switch reaches the selected position (position 4 of fig. 7), the range relay circuit is broken and the supply to the range motor cut off by the relay contact (RR2 in the selector unit).

38. The rotation of the range motor drives the shaft operating the sectioning switches SWF.

These switches introduce sections C2 and C3, respectively, of the variable capacitor in parallel with section C1 according to the range selected. Sections C4, C5 and C6 of the fixed capacitor are similarly introduced. The operation of the switches for each selected range is as follows:—

- Range 1. All switches open.
- Range 2. SWFe closed.
- Range 3. SWFd and e closed.
- Range 4. SWFc, d and e closed.
- Range 5. SWFb, c, d and e closed.
- Range 6. All switches closed.

39. The total tuned capacitance is applied to the cavity via the special 40-amp plug PL4 and socket SK4.

Range repeater switch

40. On the same shaft as the range switch SWAa is a switch which repeats the range information to the matching switch in the impedance matching unit Type 7949. This switch sector SWAb has six connections to the 12-way socket AC (pins G, H, J, K, L and M). The seventh connection is connected to the bonded frame (pin C of 25-way plug AB).

RESTRICTED

Capacitor tuning

41. The tuning motor is operated indirectly by the unbalance current of the Wheatstone bridge servo system. The potentiometer RV1 forms one arm of this bridge and its slider is driven on the same shaft as the variable capacitor. The fixed connections of RV1 are connected across the 28V supply at the pins O and N of the 8-way plug AB; the slider is connected to the centre stable relay in the selector unit via pin P of AB.

42. As shown in fig. 2 and 3 the tuning motor drives, through a gear train, the variable capacitor, the slider of the potentiometer RV1 and the limit stop of the switches SWD and SWE. The capacitor and the slider of the potentiometer are on the same shaft, the limit stop is mounted on the end of the moving vanes of the capacitor. The electrical connections from the potentiometer and the limit switches are connected to AB at pins R, Q and S; the connections of the potentiometer are given in para. 41.

Limit switches

43. The connections of the limit switches are arranged so that, when the actuating stop reaches either limit of the capacitor travel, one of the switches closes one pair of contacts and opens the other pair.

44. In each case one function of the switch is to complete the 28V supply to the LIMIT lamp on the control unit Type 7216 by connecting pin O of AB to pin Q. The second function is to open-circuit the operating tuning relay in the selector unit. This will be either relay TL/2 or TH/2 open-circuited by SWE and SWD, respectively; the circuit is broken between pin O and R of AB (SWE) or pin O and S of AB (SWD).

45. An open-circuit on either tuning relay will interrupt the supply to the tuning motor connected to pins 15 and 16 of the plug and socket PL3/SK2 and the variable capacitor will be brought to rest at the limit of its travel.

Pressure-operated switches

46. The two pressure-operated switches are mounted on one assembly (*para.* 17) and are connected as follows:—

- (1) SWB. Connected between the positive line at pin O and pin V of AB: The connection from pin V is taken via the selector unit to complete the circuit of the SAFE lamp in the control unit Type 7216. As shown in fig. 7, the pressure switch is closed until the pressure in the tuning unit canister falls below 16 lb. per sq. in. (absolute).
- (2) SWC. Connected between the negative line at TB4 and pin Y of AB. The connection from pin Y is taken via the selector unit to the control unit Type 4190 (*Sect. 1, Chap. 3*) to the "low power" relay of the transmitter. The switch is normally open, but will close to operate the low power switching when the pressure in the tuning unit canister falls below 11 lb. per sq. in. (absolute).

Negative line and earth connection

47. Three 8-way seals are used to transfer the electrical connections in the pressurized canister to the 12-way socket SK3 and the 25-way plug PL1 located on the outside cover of the canister. Since 25 connections are required to be taken through the canister, the 25th (earth) connection is connected to the frame of the mechanical drive unit (TB4) and thence to C on SK3 and PL1.

48. The earth return for the range motor, range servo switch segment SWAb and the pressure-operated switch SWC is connected to the frame (TB1) of the mechanical drive unit, which in turn, is bonded to the impedance matching unit Type 7959 via pin C of SK3.

49. When the tuning unit is removed from the canister for testing purposes this bonded earth is disconnected from the range motor, range switch and pressure-operated switch SWC. As shown in fig. 7 the earth return of the range motor etc. is connected to TB4; this has no external wiring connection and would have to be connected to a 28V negative line on the equipment before the tuning unit could be operated.

RESTRICTED

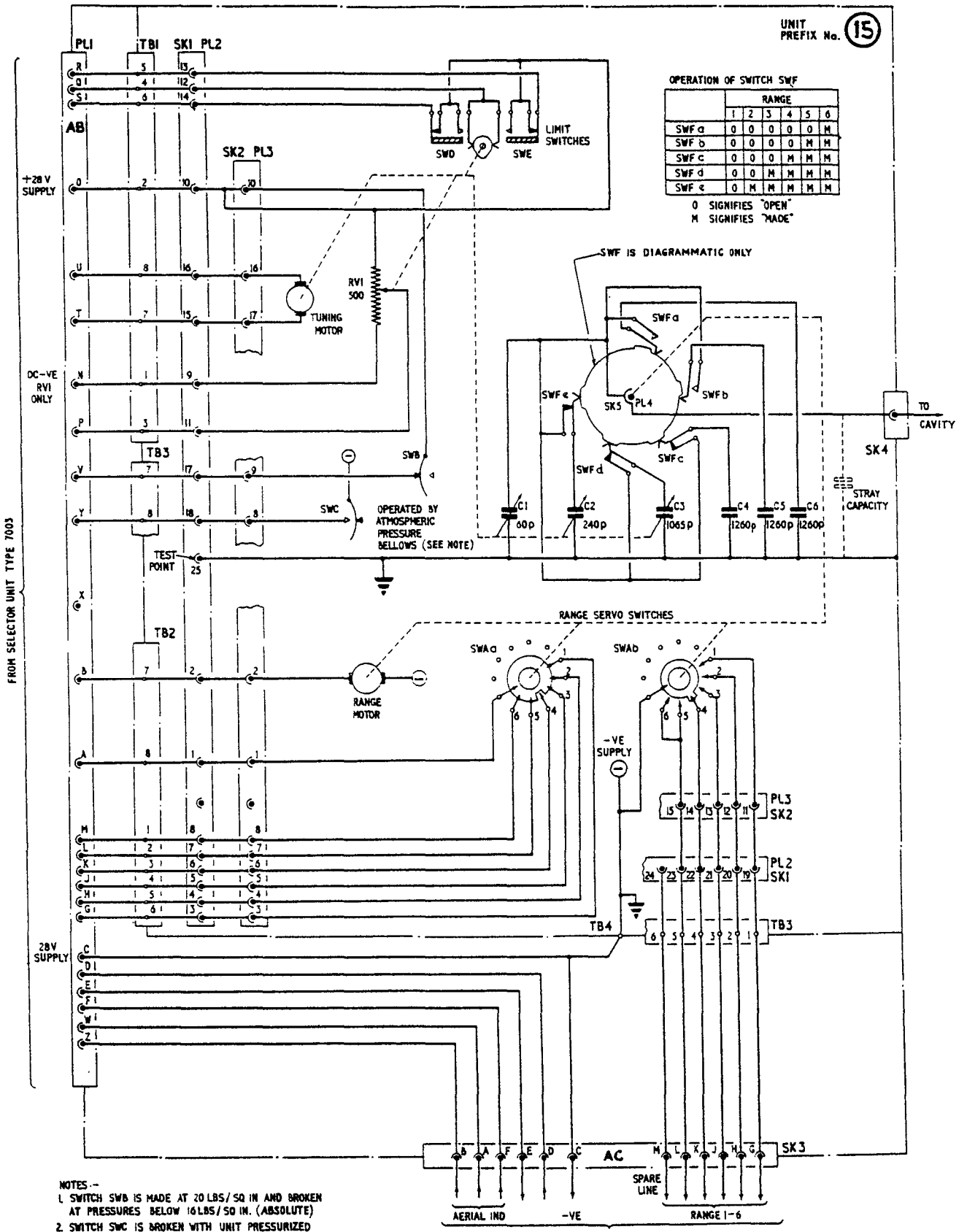

- NOTES -
1. SWITCH SWb IS MADE AT 20 LBS/SQ IN AND BROKEN AT PRESSURES BELOW 16 LBS/SQ IN. (ABSOLUTE)
 2. SWITCH SWc IS BROKEN WITH UNIT PRESSURIZED AND MADE AT PRESSURES BELOW 11 LBS/SQ IN. (ABSOLUTE)
 3. TERMINALS TB1, TB2, TB3 ARE CERAMIC SEALS
 4. TERMINAL TB4 IS A SCREW CONNECTION TO THE CANISTER ASSEMBLY.

AIR DIAGRAM
6103Q/MIN.

PREPARED BY MINISTRY OF SUPPLY
FOR PROMULGATION BY
AIR MINISTRY ADMALTY

ARI. 5874
Tuning unit (aerial) Type 7016 - circuit

Fig. 7

RESTRICTED

(A.L. 33 Mar '56)

D.2006 470927 S.W. 3/65

Chapter 7

IMPEDANCE MATCHING UNITS TYPE 7949, 7949A AND 9541

LIST OF CONTENTS

	<i>Para.</i>		<i>Para.</i>
<i>Introduction</i>	1	<i>Matching motor</i>	19
<i>Construction</i>	7	<i>Matching switch</i>	21
<i>Circuit description</i>	16	<i>Probe circuit</i>	22
<i>Line-finder switch</i>	18		

LIST OF ILLUSTRATIONS

	<i>Fig.</i>		<i>Fig.</i>
<i>Impedance matching unit Type 7949/A with switch cover removed</i>	1	<i>Impedance matching unit Type 9541</i>	3
<i>Mechanical drive unit</i>	2	<i>Impedance matching unit-circuit</i>	4
		<i>Mechanical drive unit showing coaxial plugs</i>	5

Introduction

1. Impedance matching units Type 7949, 7949A, and 9541 are used with "cavity" type suppressed aeriels. They are designed to maintain a reasonable match between the input impedance of the aircraft exciting system and the output impedance of the transmitter at all frequencies within the range of ARI.5874.

2. The function of each of the Types referred to in para. 1 is the same although the mechanical construction is slightly different in each case. The impedance matching units at present in use are as follows:

(1) Impedance matching unit Type 7949. Only two output tappings are used; terminals 1, 2 and 3 are strapped and terminals 4, 5 and 6 are strapped. When modified in accordance with Mod. No. 4620 (*Vol. 2*), this becomes Type 7949A.

(2) Impedance matching unit Type 7949A. There are no straps and therefore five output tappings are available. The sixth terminal connection is not used.

(3) Impedance matching unit Type 9541. This is similar to Type 7949A but the depth of the matching switch housing has been reduced to enable the unit to be mounted inside the aerial cavity. Mounted on the cover of the housing are two new features, *viz.* a stand-off insulator and a probe pick-up plate.

3. The units are electrically identical with the exception of the output tappings (*para. 2*) and each has a completely enclosed switch from which connections are taken to the walls of the cavity aerial. The switch is motor driven and remotely controlled by the selector unit Type 7003 (*Chap. 2.*) The line-finder servo system is identical to that used for the range switch in the aerial tuning unit Type 7016 from which the information is relayed. (*Chap. 6.*)

4. The impedance matching unit changes the connection of the coaxial feeder to the various tapping points on the wall of the cavity; these points being predetermined and variant according to aircraft type.

5. Also the number of tappings in use may vary with type of aircraft, for example there are five tappings on the Vulcan but only two on the Victor and Valiant aircraft.

6. A probe pick-up connection provides an input to the rectifier circuit in the impedance matching unit and the output from this circuit provides a meter indication of aerial resonance to the transmitter/receiver frequency.

Construction

7. The impedance matching unit Type 7949/A is illustrated in fig. 1; there are two views, one with the switch cover removed. The unit has a drive unit which is identical to the other two types of impedance matching unit with exception of Type 9541 where the coaxial plugs PL2 and PL3 are mounted on the side of the drive unit and not on the back.

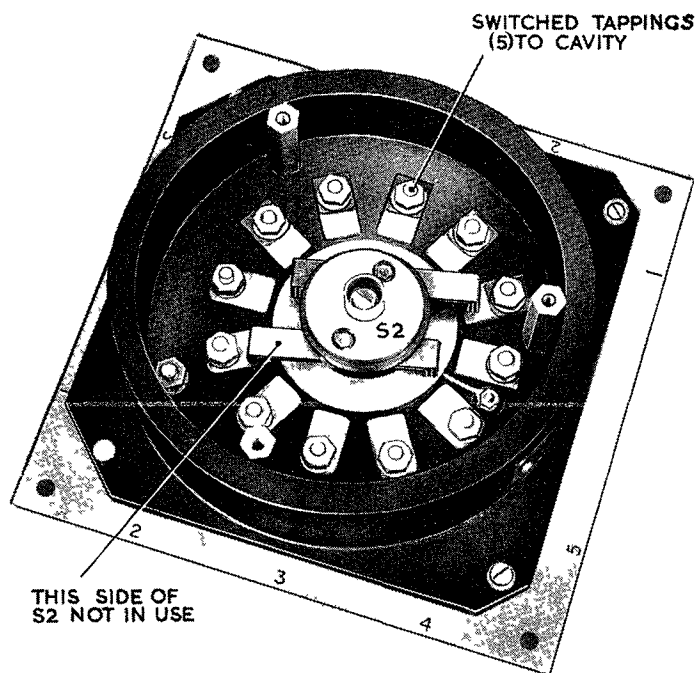
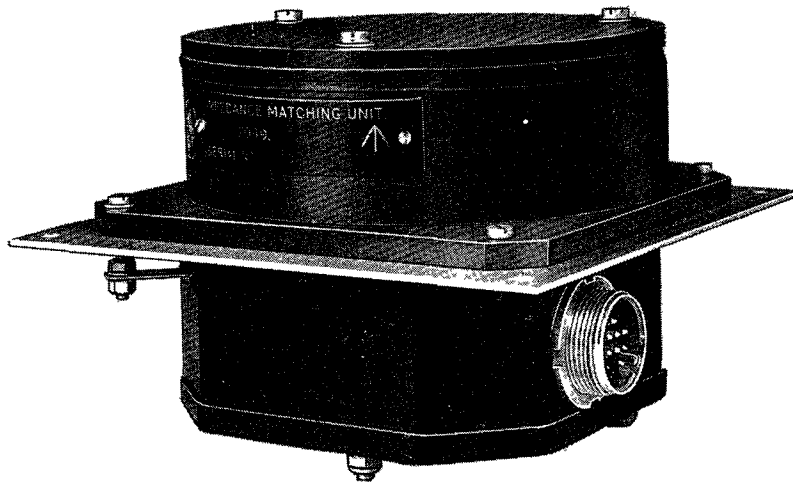

Fig. 1. Impedance matching unit Type 7949/A with switch cover removed.

8. The fixed contacts of the switch are provided with 2 B.A. nuts for the attachment of plated copper braid from which connection is made to the tapping on the wall of the cavity. These connections must be made in accordance with the instructions relevant to the type of aircraft to which the unit is fitted.

9. Access to the switch is provided by the removal of the top cover (*fig. 1*). The copper braid emerges through a double gasket which, when the cover is screwed on, holds the braid strips in position.

10. The switch contacts are motor-driven through a suitable gear train with a gear ratio of 1200 to 1 (*fig. 2*), the driving motor having an approximate

speed of 6000 rev/min. The selected position of the contacts is controlled by a wafer switch on the same shaft; this switch is incorporated in the line-finder servo system and will stop at points corresponding with those of the range switch in the aerial tuning unit.

11. At the rear of the mechanical drive unit are mounted two coaxial plugs and one 12-way multipole plug. The latter connects the line-finder servo system and the supplies to the motor-drive of the impedance matching unit. The largest of the coaxial plugs is connected to the output of the transmitter, and the smaller one accommodates the connection from the probe to pick up a measurable portion of the r.f. output from the aerial system.

RESTRICTED

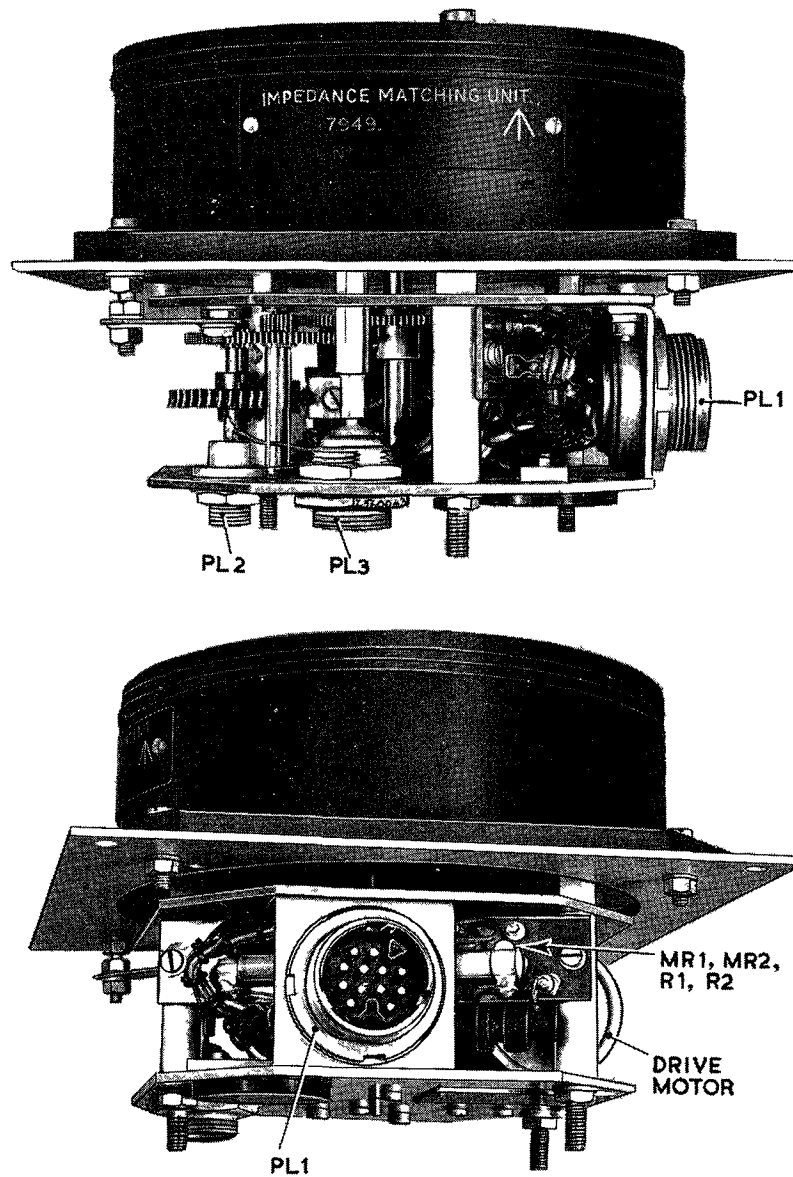

Fig. 2. Mechanical drive unit.

12. The probe connections from impedance matching units Type 7949 and 7949A are normally taken to the "output" insulator of the aerial tuning unit Type 7016. This is a convenient and suitable connection point for pickup of a measurable amount of energy and the probe lead is connected to a metal band around the insulator.

13. Impedance matching unit Type 9541 is normally mounted inside the cavity together with the aerial tuning unit (Victor aircraft) and sufficient pick-up is provided by a small metal plate mounted on the cover of the impedance matching unit itself. The remote end of the probe lead is soldered directly into a hole in the plate.

14. Also mounted on the cover of impedance matching unit Type 9541 is a stand-off insulator (fig. 3) through which is taken the aerial tuning unit connector tube when the impedance matching unit is in position in the cavity.

15. In all three types of impedance matching unit, the pick-up from the probe is applied to a detector circuit which provides two d.c. outputs of opposite polarity to operate meters at monitoring points on the selector unit Type 7003, control unit Type 7216 and control unit Type 4190 (Sect. 1).

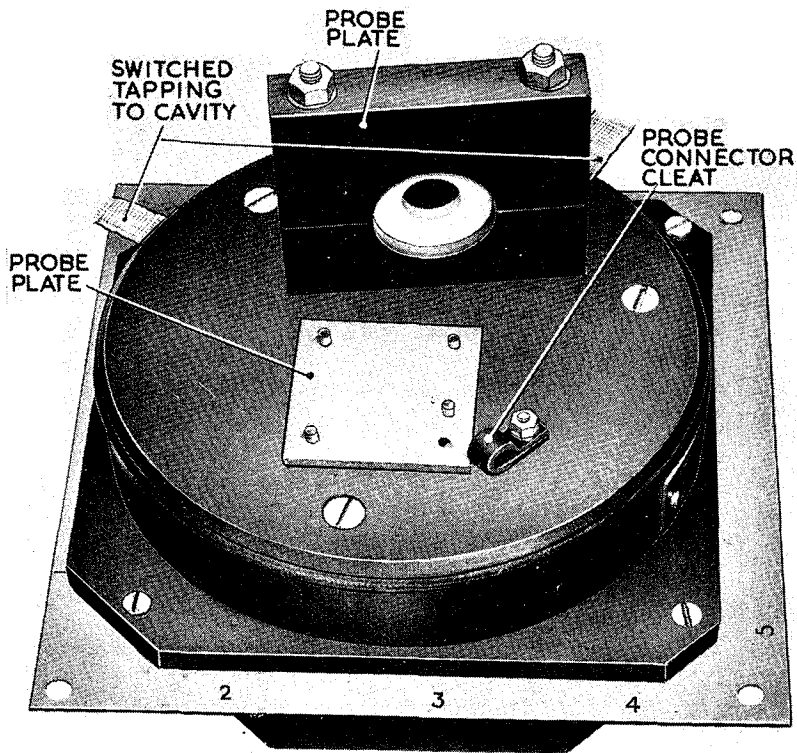

Fig. 3. Impedance matching unit Type 9541

Circuit description

16. The circuit for the three types of the impedance matching unit is identical but the external connections to the matching switch will vary for the particular installation or aircraft type. The

circuit in fig. 4 shows impedance matching unit Type 7949A connected in an installation similar to that for the Vulcan aircraft; the number of tappings within the cavity will vary for the type of aircraft.

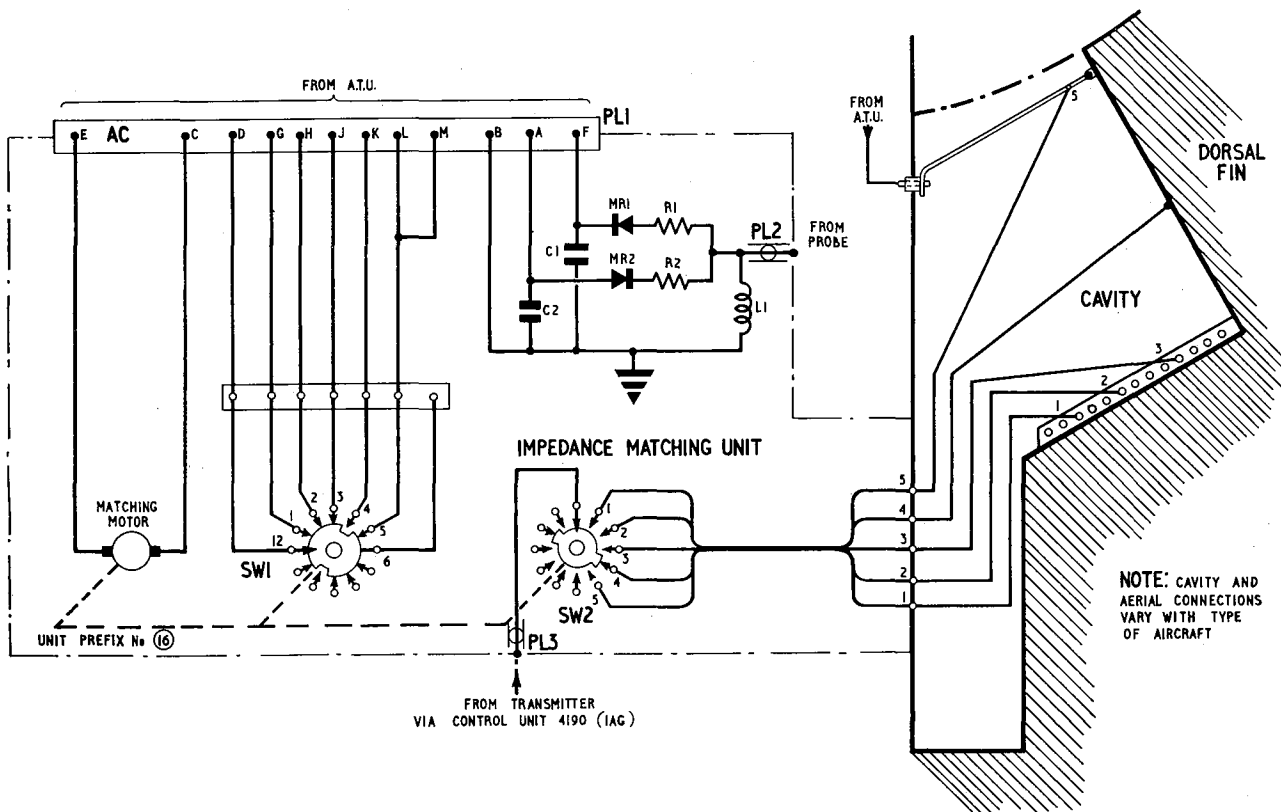

Fig. 4. Impedance matching unit—circuit

RESTRICTED

17. All external connections to the impedance matching unit are made via the 12-pole plug PL1, the two coaxial plugs PL2 and PL3 and plated copper braid connections direct to the terminals on the matching switch. Where less than five tappings are used the output terminals are sometimes commoned to match the aerial at each position of the range switch.

Line-finder switch

18. The six connections to the line-finder switch SW1 from pins G to M of the 12-way plug PL1 (AC) are made via the six "turret" tags on the unit tag panel, so that the line-finder connections associated with the tap switching can be varied to suit the requirements of different types of aircraft (*para. 5*). A seventh connection, via a pin D, is from the matching relay MR/2 (in the selector unit) which will be energized until the line-finder switch SW1 has reached the selected range (matching) position.

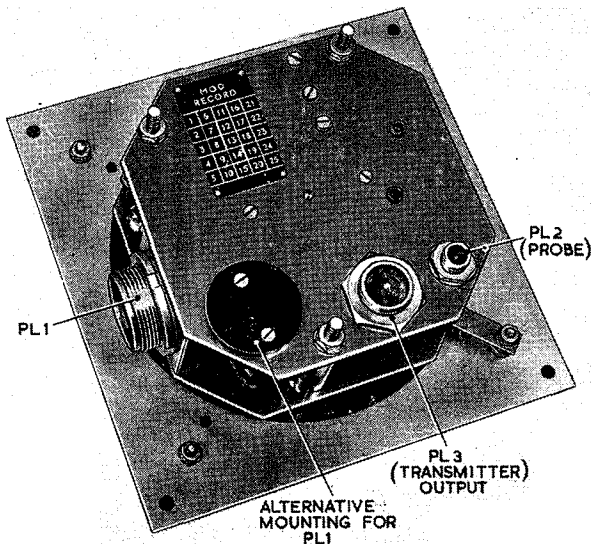

Fig. 5. Mechanical drive unit showing coaxial plugs

Matching motor

19. The matching motor drive is from the connections to pins C and E; pin C is connected to "earth" and pin E carries the 28V d.c. supply via the relay contact MR1 (in the selector unit) which will, of course, be closed during the line-finding rotation of the wafer switch SW1.

20. When the selection process is completed relay MR/2 will be de-energized and the contact MR1 will change over to "earth". Thus the supply to the matching motor is interrupted and a brake put on the motor by short-circuiting the pins C and E of the plug PL1.

Matching switch

21. The matching switch SW2, which is driven by the matching motor, is on the same shaft at the line-finder switch SW1 and connects the taps on the cavity to the transmitter output via the coaxial plug PL3 (*fig. 5*). Six switch positions are available but for existing systems only five positions are used, the wiring to the tag panel (*para. 18*) being arranged to bring the switches into the same position for frequency ranges 5 and 6.

Probe circuit

22. The probe is connected by means of a screened lead to the coaxial termination PL2. The internal connection is made at the junction of R1, R2 and L1, where the pick-up from the probe is rectified to give a positive and negative output via pins F and A, respectively, of the 12-pole plug PL1. The outputs are used to give r.f. output indications on meters in the control unit Type 7216, selector unit Type 7003 and control unit Type 4190 (*Sect. 1, Chap. 3*).

FREQ. SHIFT

7. Manual tuning on any of the ranges selected by the RANGE switch is by means of a spring-loaded key switch marked FREQ. SHIFT. This switch can be moved horizontally in either direction from the centre position and causes the tuning motor in the aerial tuning unit to be driven in either direction according to the position of the switch. During "AUTO" operation this switch will function only if the FINE/COARSE switch is in the FINE position.

8. The two operating positions of the switch are marked "L" and "H" indicating the low or high frequency direction of the tuning within the range selected by the RANGE switch.

FINE/COARSE

9. Two manual tuning speeds are available under the control of the FINE/COARSE switch. With the switch in the COARSE position the tuning motor will run fast and the transmitter will be automatically switched to low power to prevent excessive P.A. currents resulting from severe detuning.

10. At the same time shunts on the RF meter (para. 13) are changed in order to preserve an adequate reading. When the switch is returned to the FINE position the transmitter is automatically restored to its full power condition.

11. The FINE tuning position of the switch together with the FREQ. SHIFT switch enables the operator to make small readjustments during automatic operation without disturbing the preset adjustments in the selector unit (Chap. 2).

12. This fine-tuning facility is provided because small changes in the tuned circuit constants resulting from temperature variations may occasionally warrant the use of manual correction.

RF meter and SERVO CHECK switch

13. The meter at the top of the front panel has two functions. The first is to monitor the RF output from the aerial system in order that resonance with the transmitter frequency may be observed. The reading will be on the milliamp scale 0—1.

14. To check the operation of the servo system and to verify that the tuning capacitor is being driven, a SERVO CHECK switch is provided. When this switch is pressed the meter reading will indicate the traverse of the tuning capacitor in degrees with relation to its fully closed position ("0" deg.) The reading in this case will be on the POSITION scale 0—180 deg. The use of the SERVO CHECK switch will obviously indicate the existing setting of the tuning capacitor rotor and thus the operator will be aware of the direction of rotation required to establish any new setting. Because of the choice of the fully closed position as "0 deg.", increasing readings correspond to increasing frequency.

LIMIT indicator

15. Limit springsets are provided at each extreme of the angular travel of the tuning capacitor rotor; these are arranged to stop the drive and light the warning lamp marked LIMIT when the rotor reaches either limit of its travel.

SAFE indicator

16. The pressure in the tuning unit (aerial) Type 7015 is normally maintained at about 20 lb. per square inch absolute. Should this pressure fall to about 16 lb. per square inch absolute a lamp on the control unit will be switched off by the operation of a pressure-operated switch. The lamp is marked SAFE and will glow whilst the operating pressure is maintained.

17. If there should be a further fall of pressure to less than 14½ lb. per square inch absolute, another pressure-operated switch will operate to reduce the transmitter power to a safe point to prevent breakdown. The operation of the second switch is not indicated on the control unit except by a reduced output which may be shown in the milliammeter (Chap. 3).

18. A constructional view of the interior of the control unit is given in fig. 2.

CIRCUIT DESCRIPTION

19. The circuit of the control unit Type 7216 is not complete in itself for obvious reasons. The following description, therefore, is devoted to the interconnection of the control unit switches with other units of the aerial system.

20. All the circuit wiring of the control unit is taken out through the 18-way plug and connector AA to the selector unit Type 7003. The connections to the plug are shown in fig. 3.

21. The main function of the AUTO/MAN switch is to transfer control of the system from the selector unit (AUTO operation) to the control unit (MAN operation). During AUTO operation this switch "earths" pins A and B of the 18-way plug; pin A provides the "earth" return for the channel selector motor in the selector unit.

22. The "earth" on pin B of the 18-way plug is applied to one of two circuits according to the

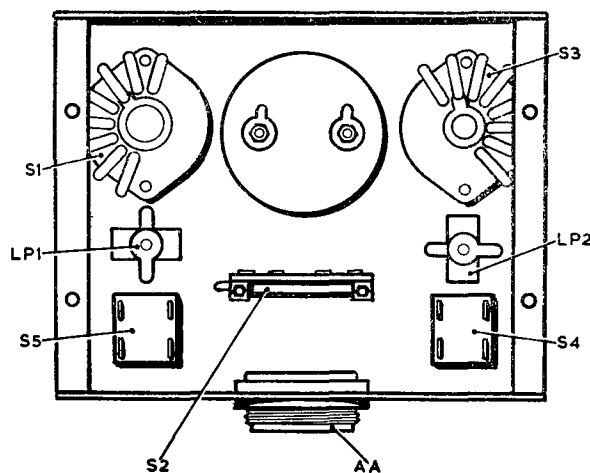

Fig. 2. Inner view of control unit

RESTRICTED

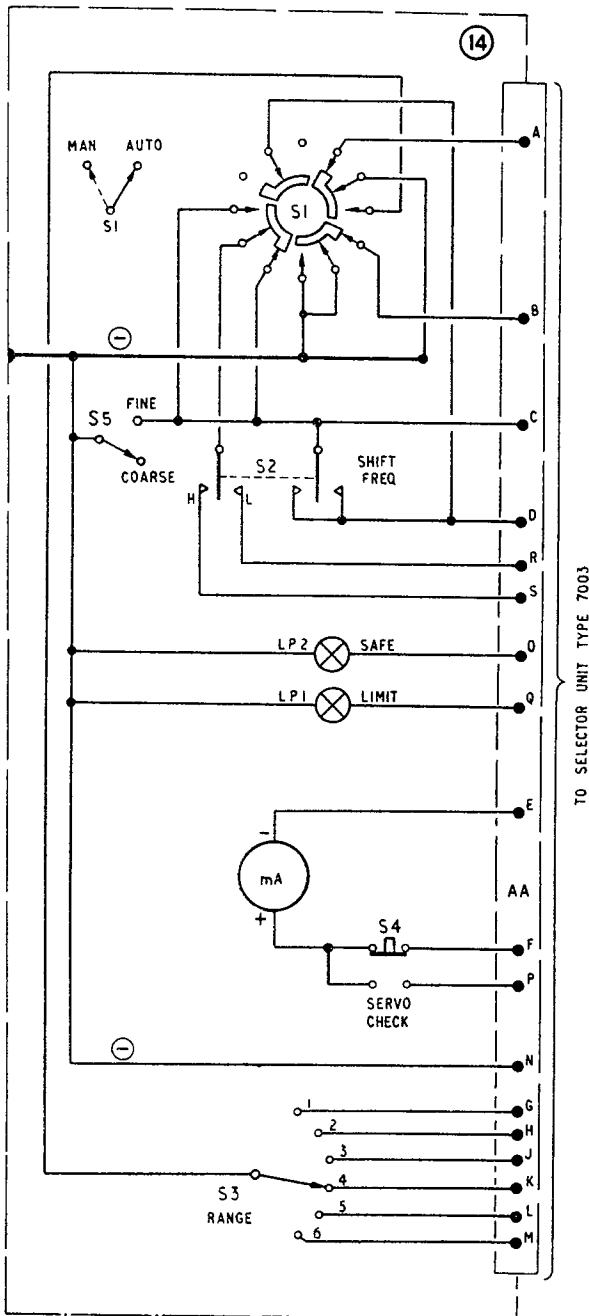

Fig. 3. Control unit Type 7216—circuit

position of contacts CSB1 of relay CSB in the selector unit as follows:—

- (1) "Earths" the system TUNE line and so prevents transmitter keying during channel selection.
- (2) "Earths" relays AMA and AMB on completion of channel selection, causing these to operate and switch in the preset controls in the selector unit.

23. In the MAN position of the switch these two connections are broken and so isolate the entire

automatic channel selection system in the event of breakdown, or when MANUAL control is required for any other reason.

24. The remaining two poles of the switch are used

- (1) to disconnect the manual RANGE switch during AUTO operation and
- (2) to vary the connections of the FINE TUNING circuits as described in para. 25.

25. If AUTO operation is in use, operation of the FINE/COARSE switch to FINE earths pin C of the 18-way plug AA and both poles of the SHIFT FREQ. switch S2. Consequently, operation of the latter now

- (1) operates one or other of the tuning relays TL and TH in the selector unit and
- (2) operates the fine tuning relays FTA and FTB, by earthing pin D of the 18-way plug.

Once operated these relays remain held, even when the SHIFT FREQ. switch is released, because of the "latching" circuit via relay contacts FTA1 and AMA1 back to pin C.

26. Operation of the FINE TUNING relays disables the Wheatstone bridge servo system in the selector unit and so places tuning under the control of the SHIFT FREQ. switch. It also introduces resistance into the armature circuit of the tuning motor and reduces its operating speed.

27. These conditions remain effective until cancelled by either

- (1) switching back to COARSE tuning,
- (2) switching to MANUAL operation, or
- (3) changing channel (which releases the "latching" circuit by releasing relay AMA).

28. If MANUAL operation is in use, pole "a" of the SHIFT FREQ. switch is directly earthed via the AUTO/MAN switch and the tuning relays can be operated by means of the SHIFT FREQ. switch which can now earth the tuning relay connections (pin R or pin S) even with the FINE/COARSE switch in the COARSE position. Thus high speed tuning is possible under MANUAL control.

29. During MANUAL operation, pins C and D of the 18-way plug are permanently connected together by the AUTO/MAN switch and operation of the FINE/COARSE switch to FINE operates relays FTA and FTB immediately. Operation of these relays ensures that the Wheatstone bridge servo system cannot operate, even under conditions of fault elsewhere. It also slows down the tuning motor (para. 25).

RESTRICTED

30. During COARSE tuning (MANUAL operation), the transmitter is automatically switched to low power, the LOW POWER line being earthed via relay contacts FTA2 and AMA2. On switching to FINE tuning, this earth is removed by the operation of relay FTA, so that fine tuning adjustments can be made with the transmitter operating at full power.

31. Frequency range can be selected when the AUTO/MAN switch is in the MANUAL position. The RANGE switch will select six ranges identical to those selected by the automatic operation of the equipment. The outgoing connections of the RANGE switch are to pins G, H, K, L and M of the 18-way plug.

32. The normal connections of the milliammeter are via pins E and F of the 18-way plug; the reading giving an indication of RF output. When the SERVO CHECK switch is pressed the meter connection is changed over from pin F to pin P. The connections to the meter are then from the "Wheatstone Servo" circuit and the reading will give an indication of the angular position of the tuning capacitor at any moment of operation. The reading of the scale in this case is in degrees.

33. The two indicating lamps SAFE and LIMIT are connected between earth and pins O and Q respectively.

RESTRICTED

Chapter 10

SUPPRESSED AERIAL INSTALLATION

(ARI.5874)

LIST OF CONTENTS

	Para.		Para.
<i>Introduction</i>	1	<i>Tuning unit (aerial) Type 7015</i>	18
<i>Racking system and back-plates</i>	4	<i>Impedance matching unit Type 7217</i>	19
<i>Back-plates</i>	9	<i>Inductor Type 7006</i>	20
<i>Method of fitting back-plates</i>	13	<i>Installation and cabling</i>	21
<i>Units installed outside the racking</i>		<i>Fixed equipment</i>	22
<i>Control unit type 7216</i>	17	<i>Removable equipment</i>	25
		<i>Connectors</i>	26
		<i>Equipment wires specification</i>	28

LIST OF TABLES

	Table		Table
<i>Connector and unit coding</i>	1	<i>Removable equipment</i>	4
<i>Back-plate jigs</i>	2	<i>Connector schedule...</i>	5
<i>Fixed equipment</i>	3		

LIST OF ILLUSTRATIONS

	Fig.		Fig.
<i>Back-plate and connections to rear panel of selector unit Type 7003</i>	1	<i>Method of fitting back-plate with jig ARI.5874 with suppressed aerial system Type 7215</i>	2
			3

INTRODUCTION

1. The airborne installations to be described in this chapter come under the general heading "ARI.5874"; the variant installations under this heading take into consideration the type of energization and type of aircraft in which the installation is fitted, e.g.

- (1) Suppressed aerial installation with coil excitation as used in some Valiant aircraft.
 - (2) Suppressed aerial installation with cavity excitation as used in some Valiant aircraft.
 - (3) Suppressed aerial installation with notch excitation as used in the Vulcan aircraft.
2. At the time of writing the type of suppressed aerial installation in use is coil excitation of the Valiant aircraft as described in the following paragraphs.
3. The main units of the complete installation are described in this Section and in Section 1. The back-plates of the transmitter, receiver and ancillary equipment are described in Chap. 10, Section 1.

All the connectors, the back-plates of the units of the suppressed aerial equipment and all other installation details are described in this Chapter.

RACKING SYSTEM AND BACK-PLATES

4. The construction of the racking system will normally be carried out by the aircraft constructor. The racking conforms with that described in the British Standards Institution publication "Sizes and Forms of Civil Aircraft Radio Equipment".
5. The racking consists of horizontal U-shaped channel members on which are mounted a number of left and right side members. The latter are cut to suit the lengths of individual units and positioned on the horizontal members to the width required to accept the unit.
6. Each set of left and right side members when mounted on the horizontal members forms a mounting tray for the particular unit. The "rear" ends of the side members are flanged for fitment of the back-plates carrying the plugs and sockets which mate with the associated sockets and plugs on the rear panel of the individual units (para. 14).

RESTRICTED

7. As many units, or multiples of a complement of units, as may be required can be mounted on the racking system. In some aircraft the horizontal members will be mounted in tiers (generally two) one above the other to form a square or rectangular rack.

8. The completed racking is mounted on anti-vibration mountings based on a rack loading of 2.5 lb. per inch run. It may be necessary to fit additional anti-vibration mountings to those at the ends of the rack when several heavy units are mounted on the same rack.

Back-plates

9. Interconnection between the individual units of an installation is made by engaging the plugs and sockets on the rear panel of the units with the respective sockets and plugs on the ends of the cables located in the back-plates on the racking system.

10. The back-plates are positioned on the mounting with the aid of special jigs listed in Table 2. If the back-plates were fitted without the use of jigs serious misalignment would probably occur with resultant damage to the plugs and sockets of the equipment and the back-plates. The method of fitting a back-plate with the aid of a jig is described in para. 13.

11. Each back-plate carries two locating spigots which align the individual units to the associated back-plate. To improve mating, the multi-pole plugs and sockets will tolerate a small amount of misalignment. The coaxial sockets on the back-plates are designed to "float" for the same reason.

12. Each of the plugs and sockets on the rear panel are numbered in accordance with the circuit references, but the numbering of the plugs and sockets on the back-plates is related to the particular connector which it terminates, e.g. the socket AA on the rear panel of selector unit Type 7003 will connect with the 20-way plug 13AA on the back-plate (fig. 1); the plug is one termination of the 20-core connector AA, the other end being connected to the control unit Type 7216 at socket 14AA (fig. 3). The coding of the back-plates, of individual units, and the associated cables is given in Table I.

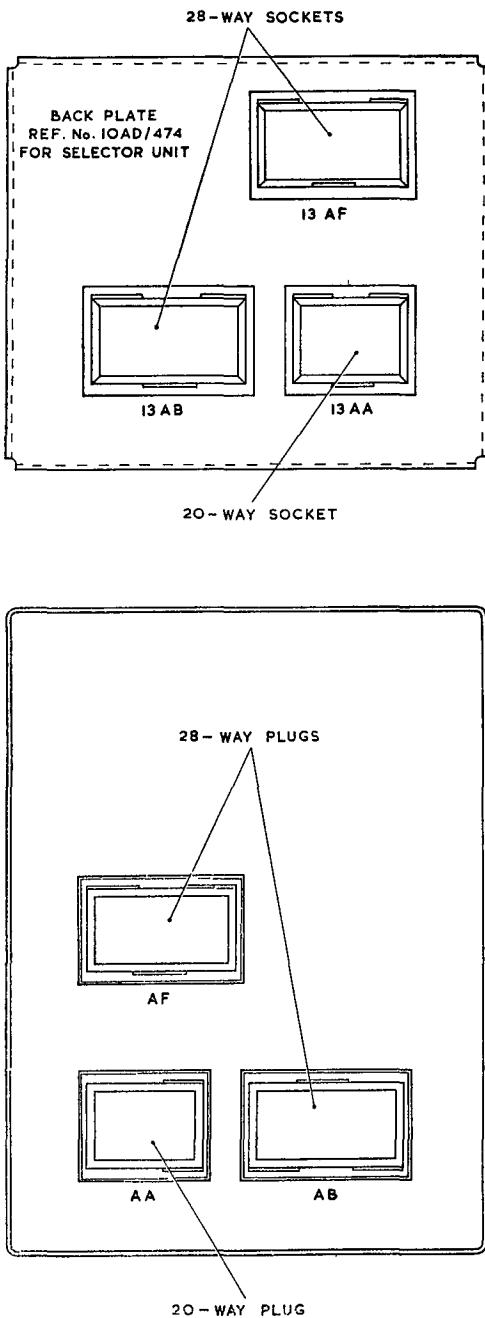

Fig. 1. Back-plate and connections to rear panel of selector unit Type 7003

TABLE I

Connector and unit coding

	<i>Unit</i>			<i>Code</i>
Control unit Type 4190	1
Transmitter Type T.4188	2
Power and radio unit Type 4192	3
Receiver Type R.4187	4
Control unit (remote) Type 4189	11
Junction box Type 4191	12
Selector unit Type 7003	13
Control unit Type 7216	14
Tuning unit (aerial) Type 7015	15
Impedance matching unit Type 7217	16
Voltage regulator	—

Table I—contd.

Connector Code		Terminations		
A	1A	Control unit Type 4190	3A	Power and radio unit
B	1B	Control unit Type 4190	2B	Transmitter
C	1C	Control unit Type 4190	2C	Transmitter
D	2D	Transmitter	3D	Power and radio unit
E	2E	Transmitter	3E	Power and radio unit
F	3F	Power and radio unit	—	Intercom. equipment
G		—		—
H		—		—
J	3J	Power and radio unit		External transmitter interlock or transmitter Type T.4188 shorting plug
K		—		—
L	1L	Control unit Type 4190	4L	Receiver
M	4M	Receiver	—	Power supplies
N	3N	Power and radio unit	4N	Receiver
P	3P	Power and radio unit	—	Power supplies
AA	13AA	Selector unit Type 7003	14AA	Control unit Type 7216
AB	13AB	Selector unit Type 7003	15AB	Tuning unit (aerial) Type 7015
AC	15AC	Tuning unit (aerial) Type 7015	16AC	Impedance matching unit Type 7217
AD	4AD	Receiver	12AD	Junction box
AE	1AE	Control unit Type 4190	12AE	Junction box
AF	1AF	Control unit Type 4190	13AF	Selector unit Type 7003
AG	1AG	Control unit Type 4190	16AG	Impedance matching unit Type 7217
AH	11AH	Control unit (remote) Type 4189	12AH	Junction box
AL	16AL	Impedance matching unit Type 7217	—	To probe wire on Inductor Type 7006

Method of fitting back-plates

13. The method of fitting a back-plate to the racking system is shown in fig. 2. The associated jig (Table 2) is laid in a horizontal position across the rear ends of the left and right vertical side-members so that the jig runs parallel with the rear U-shaped channel member. The "top" side of the jig is marked "This side up". Other markings will be (e.g.) "Jig Ref. No. 10AG/56 for Back-plate 10AG/56" (Table 2).

14. The back-plate is then lowered vertically at the back of the flanged ends of the side members

until the locating spigots on the back-plate come to rest on the upper face of the rectangular jig.

15. With the back-plate and jig in this position the fixing screws of the back-plate which pass through the flanged ends of the side members, should be tightened until the back-plate is securely locked in position.

16. A further scrutiny should be made to ensure that the back-plate is properly aligned with the jig and the side members and the jig then finally removed.

RESTRICTED

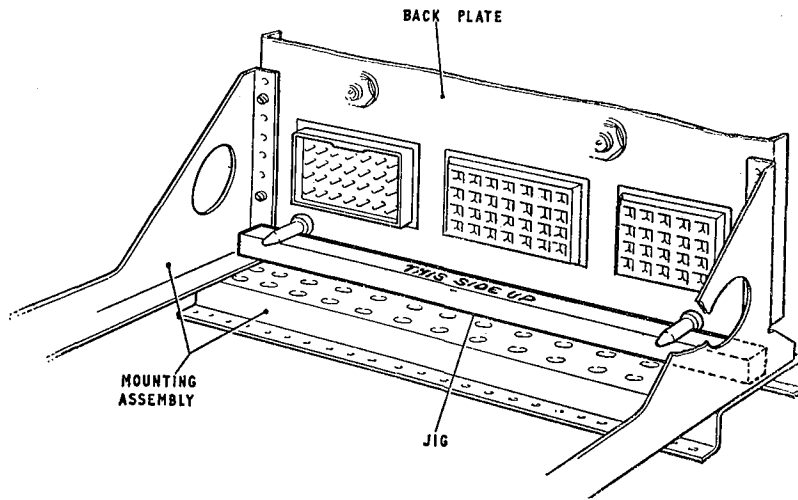

Fig. 2. Method of fitting back-plate with jig

TABLE 2
Back-plate jigs

The following jigs must be used when assembling back-plates on the racking system

A.M. Stores Ref.	Back-plate	Unit
10AG/51	Jig, locating (Back-plate 10AR/438)	For power and radio unit Type 4192
10AG/52	Jig, locating (Back-plate 10AR/440)	For transmitter Type R.4188
10AG/53	Jig, locating (Back-plate 10AR/441)	For control unit Type 4190 (or 4243)
10AG/54	Jig, locating (Back-plate 10AR/442)	For receiver Type R.4187
10AG/55	Jig, locating (Back-plate 5UC/6011)	For voltage regulator 5UC/6010
10AG/56	Jig, locating (Back-plate 10AR/474)	For selector unit Type 7003

UNITS INSTALLED OUTSIDE THE RACKING

Control unit Type 7216

17. The control unit Type 7216 is not mounted on the racking system but is constructed so that it may be panel or console mounted. This unit is not fitted with anti-vibration mountings.

Tuning unit (aerial) Type 7015

18. Since the aerial tuning unit is mounted in close proximity to the energizing coil, it is provided with its own mounting tray. This tray is triangular in shape and is fitted with three anti-vibration mountings. The tuning unit canister is secured to the mounting tray by a 3-point "quick-release" mounting, the mounting tray being bolted to the airframe in a conventional manner. The mounting tray is illustrated in Chap. 3.

Impedance matching unit Type 7217

19. The impedance matching unit is mounted "in" the skin of the aircraft so that one side of the unit is external to the fuselage and the other side of the unit projects through the skin to the interior of the aircraft. No anti-vibration mountings are used and the unit is secured to the airframe by a bracket which may be considered as an integral part of the unit.

Inductor Type 7006

20. The inductor Type 7006 is fitted to a mounting bracket which is secured to the inside of the aircraft wing; this mounting is an "aircraft fit" and is not a part of ARI.5874 (Chap. 5). The inductor is connected to the bracket via four anti-vibration mountings.

Note . . .

Control unit Type 4189 may be panel or console mounted; junction box Type 4191 is panel mounted (Sect. 1).

INSTALLATION AND CABLING

21. There are variant installations in the one designation ARI.5874, the complement of movable equipment and cabling being different in each case. In the following description information is given on the main items of equipment and ancillaries which make up the installation for coil-excitation of the Valiant aircraft.

Fixed equipment

22. The items in Table 3 are listed as the fixed equipment required for the aircraft installation; the items are normally supplied to the aircraft contractor for installation at the works.

RESTRICTED

TABLE 3
Fixed equipment

A.M. Stores Ref.	Description	Service	Dimensions (approx.)	
			Width	Height
10AD/474	Back-plate	For selector unit	5 $\frac{7}{8}$ in.	× 5 in.
10AR/438	Back-plate	For power and radio unit	10 in.	× 5 in.
10AR/440	„ „	For transmitter T.4188	7 $\frac{1}{4}$ in.	× 3 in.
10AR/441	„ „	For control unit Type 4190	7 $\frac{1}{4}$ in.	× 7 in.
10AR/442	„ „	For receiver R.4187	7 $\frac{3}{4}$ in.	× 3 in.
5UC/6011	„ „	For voltage regulator (5UC/6010)	3 $\frac{3}{4}$ in.	× 5 in.
—	Terminal blocks	As shown in fig. 3	—	—
—	Switch label	Marked "ARI.5874 ON/OFF"	—	—
—	Switch label	Marked "TRANSMITTER OUTPUT HIGH/LOW"	—	—
10AJ/162	Mounting Type 7157	For tuning unit (aerial) Type 7015 (includes 3 mountings Type 971—A.V. type 12 lb.)	—	—

23. An illustration of the complete installation for coil-excitation of the Valiant aircraft is shown in fig. 3. (For information on fixed wire aerial installations reference must be made to Sect. 3.)

the exception of those units which have direct entry plugs and sockets.

24. The interconnections of the installation are shown as they are connected to the back-plates with

Removable equipment

25. The following items are listed as removable and include the main units of the installation.

TABLE 4
Removable equipment

A.M. Stores Ref.	Description	Service	Approx. weight
5UC/6010	Voltage regulator	Stabilized 19V supply to equipment	10.75 lb.
10L/16204	Control unit (remote) Type 4189	Remote control of transmitter/receiver and aerial equipment	2.65 lb.
10D/19066	Junction box Type 4191	Junction box between remote control unit and transmitter/receiver	1.4 lb.
10L/16205	Control unit Type 4190	Control unit and drive unit for transmitter	13.6 lb.
10D/19065	Transmitter Type T. 4188	For use with suppressed or open wire aerial system	15.8 lb.
10D/19064	Receiver Type R.4187	For use with suppressed or open wire aerial system	26 lb.
10D/19067	Power and radio unit Type 4192	HT power supplies for transmitting circuits	34 lb.
10L/293	Control unit Type 7216	For manual control of aerial equipment during setting-up and operation	1.75 lb.

RESTRICTED

TABLE 4—contd.

A.M. Stores Ref.	Description	Service	Approx. weight
10D/19248	Selector unit Type 7003	For pre-selection of aerial frequencies and automatic operation of servo systems	17 lb.
10B/16777	Impedance matching unit Type 7217	For matching aerial impedance to output of transmitter	—
10C/20842	Inductor Type 7006	For excitation of airframe	—
10D/19242	Tuning unit (aerial) Type 7015	Aerial tuning unit	—

Connectors

26. The connectors described in Table 5 are for a complete coil excitation installation in the Valiant aircraft.

27. Against the sleeve marking at each end of the connector is a reference in parenthesis; this is the code marking appearing on the back-plate against the socket or plug termination of the particular connectors (*Table 1*).

Equipment wires specification

28. The equipment wires referred to in the following tables are listed in Defence Specification

DEF-12 "Equipment Wires" (1st May, 1953) which includes the following note:—

"The American - British - Canadian Supply Classification (A.B.C.S.C.) 'Class' number for the wires specified in this DEF. Specification is 6145. This number and the item identification number shown in the tables make up the Catalogue number which should be quoted when reference is made to a particular wire, e.g. 6145-100168. Equipment wires shall be described by the Catalogue number followed by the name, type number, the conductor details and colour, e.g. 6145-100192, electrical equipment, Type 2S. 7/0-0076 in Red".

TABLE 5
Connector schedule

The connectors in this schedule include those of the suppressed aerial equipment (coil excitation—Valiant)

Item in Fig. 3	Identity sleeve marking Type and Ref. No.	Overall length of cable	Destination sleeve marking		Remarks
			End A	End B	
1	EX/20C/6 (10HA/14145)	5 ft. 6 in.	*Control unit Type 4190 (1A)	Power and radio unit (3A)	<i>Pin to Pin</i> Wire 6145-100179 to Pin No. 1, 4, 5, 6, 7, 8, 9, 10, 11, 12, 13, 15, 16, 17, 18, 19, 20 Wire 6145-100229 to Pin No. 2, 3, 14
2	EX/20C/7 (10HA/14146)	4 ft. 0 in.	*Power and radio unit (3D)	Trans T4188 (2D)	<i>Pin to Pin</i> Wire 6145-100168 to Pin No. 3, 4, 5, 8, 10, 13, 14, 19, 20, 28 Wire 6145-100179 to Pin No. 6, 7, 9, 11, 12, 16, 17, 25, 27, 15 Wire 6145-100229 to Pin No. 1, 2, 24 Wire 6145-100249 to Pin No. 22
3	E23/40F/2 (10HA/14147)	†6 ft. 0 in.	Power and radio unit (3F)	Intercom.	INTERCOM. CONNECTIONS <i>Pin Colour Sleeve</i> 1 Red Tel Pos 2 Blue Tel Neg & E 3 Green Mic 4 Yellow Mic 5 White Key 6 Black Power SW 7, 8 Earth (Screen) Sextometvinsmall

RESTRICTED

TABLE 5—contd.

Item in Fig. 3	Identity sleeve marking Type and Ref. No.	Overall length of cable	Destination sleeve marking		Rémarks
			End A	End B	
4	EX/40F/2 (10HA/14148)	—	TX Shorting plug (3J)	—	Pins 1 and 2 normally shorted with 22 S.W.G. tinned copper wire sleeved with P.V.C.
5	EX/50F/6 (10HA/14149)	†12 ft. 0 in.	*Recvr. R4187 (4M)	Power supply	{ POWER SUPPLY CONNECTIONS (3 off Unipren 12) <i>Pin</i> 4 1 3 <i>Sleeve</i> 24V E 19V
6	EX/20C/8 (10HA/14150)	3 ft. 9 in.	*Recvr. R4187 (4N)	Power and radio unit (3N)	
7	EX/50F/7 (10HA/14151)	†12 ft. 0 in.	*Power and radio unit (3P)	Power supply	<i>Dupren 35 Unipren 12</i> Pin Nos. 1 to 10 cores to be marked "Earth" (Cable <i>Dupren 35 Blue</i>) Pin Nos. 13 to 20 cores to be marked "28V Pos." (Cable <i>Dupren 35 Red</i>) Pin Nos. 11 and 12 cores to be marked "19V Pos." (Cable <i>Unipren 12</i>)
8	E14/30C/3 (10HA/14152)	8 ft. 6 in.	Recvr. 4187 (4AD)	J. Box 4191 (12AD)	Pin to Letter Consecutive 25 Metvinsmall 2-5
9	E14/30C/4 (10HA/14153)	6 ft. 3 in.	Control unit 4190 (1AE)	J. Box 4191 (12AE)	Pin to Letter Consecutive 25 Metvinsmall 2-5
10	E14/20C/4 (10HA/14154)	3 ft. 9 in.	**Control unit 4190 (1AF)	Selector unit (13AF)	Pin to Pin 1-25 25 Metvinsmall 2-5
11	E31/30B/2 (10HA/14155)	7 ft. 0 in.	**Selector unit (13AA)	Aerial control unit 7216 (14AA)	Pin to letter consecutive 18 Metvinsmall 2-5
12	E14/30C/5 (10HA/14156)	9 ft. 0 in.	**Selector unit (13AB)	Break AB	Pin to letter consecutive 25 Metvinsmall 2-5
13	B/14/20C/12 (10HA/14169)	14 ft. 0 in.	Break AB	Aerial tuning unit (15AB)	
14	D270/31C/1 (10HA/14157)	7 ft. 0 in.	Control unit 4190 (1B)	Trans. T4188 (2B)	Uniradio 70
15	D221/32C/3 (10HA/14158)	6 ft. 6 in.	Control unit 4190 (1C)	Trans. T4188 (2C)	Uniradio 21
16	D221/32C/4 (10HA/14159)	3 ft. 0 in.	Power radio unit (3E)	Trans. T4188 (2E)	Uniradio 21
17	D270/31C/2 (10HA/14160)	6 ft. 0 in.	Control unit 4190 (1L)	Recvr. R4187 (4L)	Uniradio 70
18	D221/31C/3 (10HA/14161)	10 ft. 0 in.	**Control unit 4190 (1AG)	Imp. match. Unit Break AG	Uniradio 21
19	D221/30C/2 (10HA/14168)	14 ft. 0 in.	Break AG	Imp. match. (16AG)	Uniradio 21

RESTRICTED

TABLE 5—contd.

Item in Fig. 3	Identity sleeve marking Type and Ref. No.	Overall length of cable	Destination sleeve marking		Remarks
			End A	End B	
20	B12/20C/10 (10HA/14170)	2 ft 6 in.	**Aerial tuning unit (15AC)	Imp. matching unit (16AC)	12 Metvinsmall 2-5
21	B14/20C/13 (10HA/14162)	2 ft. 3 in.	J. Box 4191 (12AH)	Control unit 4189 (11AH)	25 Metvinsmall Pin to Pin 1-25
22	EX/50F/8 (10HA/14163)	<i>Dupren</i> 35 11 ft. 6 in. <i>Unipren</i> 12 0 ft. 6 in.	*Voltage regulator	Supply	Pins 1 to 7 cores to be marked "24V Pos. IN" Cable <i>Dupren</i> 35 Red. Pin 12 core to be marked "EARTH" cable <i>Unipren</i> 12 Pins 13 to 15 and 17 to 20 to be marked "19V Pos. OUT" Cable <i>Dupren</i> 35 Blue
28	D243/50E/2 (10HA/14171)	4 ft. 0 in.	**Imp. Match. unit (16AL)	Probe	Uniradio 43

Cables marked * are made up cables in polythene sleeving as there are no miniature cables in use which would meet the requirements.

Cable marked ** are for suppressed aerial installations only.

Cable lengths marked † include cut-back of 3 in. at the End B.

RESTRICTED

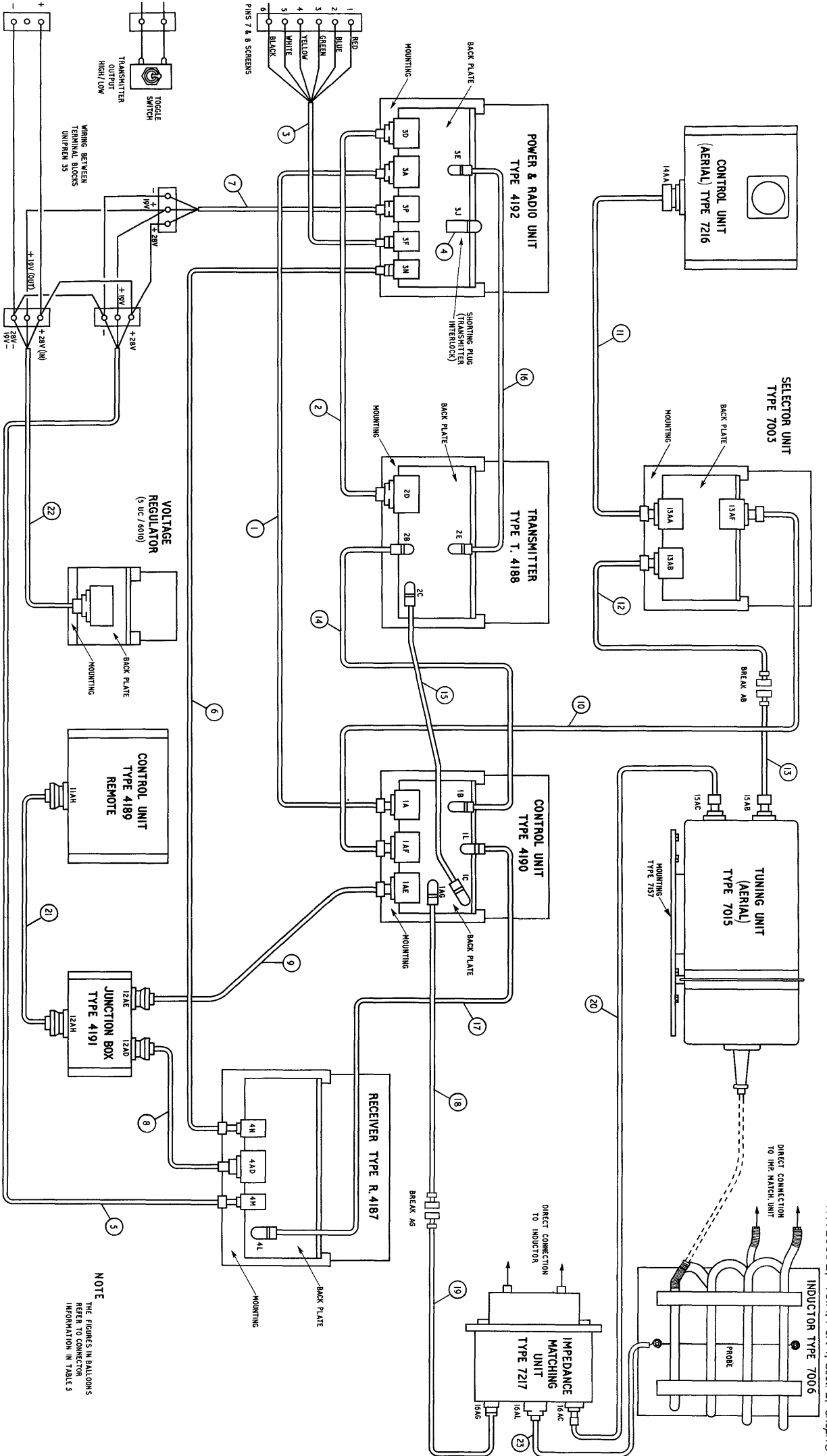

ARI. 5874 with suppressed aerial system Type 7215

R E S T R I C T E D

Fig 3

(A.L.18, May. 55)

537844 / 2484 625 655 8184 Gr. 979

Chapter 12

CIRCUIT DESCRIPTION OF AERIAL SYSTEM TYPE 9502

LIST OF CONTENTS

	Para.		Para.
Introduction	1	Special DC negative connection of range motor	42
Overall function of circuit	4	Range and impedance matching	44
Frequency coverage	8	Cavity tapping switch	46
Frequency ranges	9	Probe circuit	49
Impedance matching	10	Range selection (AUTO)	54
Detailed circuit description		Tuning (MANUAL)	57
Introduction	11	Tuning (AUTO)	75
Power supplies	12	Mechanical anti-hunt device	92
Functional sub-division of circuit	14	Fine tuning (AUTO and MANUAL)	101
Procedure for tuning the aerial system	15	Keying (tune) interlock	110
Channel selection (AUTO only)	20	MANUAL operation	114
Precaution against failure of automatic channel selection	35	AUTO operation	117
Range selection (MANUAL)	38	Setting up	118
		TEST lamp circuit	119
		TUNE operation	124
		Low power operation and RF monitoring	130

LIST OF TABLES

	Table		Table
Function of relays in aerial system Type 9502	1	Sub-circuit and relay operation	2

LIST OF ILLUSTRATIONS

	Fig.		Fig.
Block schematic of aerial system Type 9502	1	Simplified circuit of range and matching relays	5
Simplified connections between transmitter-receiver equipment and aerial system Type 9502	2	Simplified limit, safe and low power circuits	6
Operation of channel "letter" and "number" selection on rotating turret	3	Simplified circuit of RF monitoring and servo check device	7
Simplified circuit of AUTO/MAN tuning and fine tuning relays	4	ARI.5874—Aerial system Type 9502—circuit ◀ for Valiant	8
		ARI.5874—Aerial system Type 9502—circuit for Vulcan ▶	9▶

INTRODUCTION

1. This chapter is devoted to a circuit description of the cavity-excited suppressed aerial system known as aerial system Type 9502 and its interconnection with the transmitter-receiver installation; it is based on the overall circuit of aerial system Type 9502 given in fig. 8 ◀ and 9. ▶

2. Because of the nature and complexity of the aerial circuit and the servo systems a certain amount of setting-up and operating information forms an integral part of the circuit description. For practical information on setting-up and operating the aerial equipment with the transmitter-receiver equipment, reference must be made to Chapter 13 of this section.

3. The circuits in fig. 8 ◀ and 9 are ▶ necessarily terminated at ◀ the ▶ junction with the control and drive unit of the transmitter-receiver equipment,

but the interconnection ◀ at this junction ▶ is shown in the simplified diagram fig. 2. Simplified circuits of the aerial circuit and servo system are given in fig. 3 to 7.

OVERALL FUNCTION OF CIRCUIT

4. A simplified block schematic diagram of the overall circuit of the aerial system Type 9502 is given in fig. 1. This should be studied in conjunction with the following description before reference is made to the complete circuit diagram and the detailed description in para. 15 onwards.

5. The tuned aerial circuit is formed by the cavity in the aircraft and the variable capacitor of the tuning unit Type 7016. This circuit is automatically brought into resonance at the operating frequency of the transmitter-receiver equipment by the selector unit Type 7003.

RESTRICTED

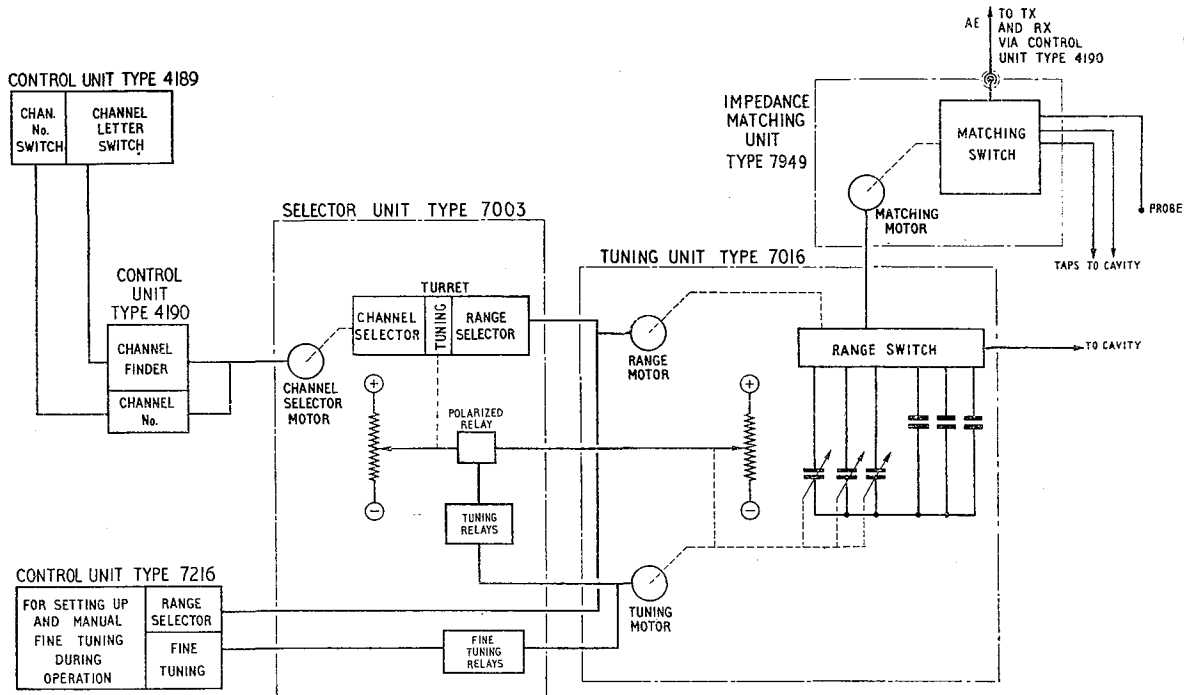

Fig. 1. Block schematic of aerial system Type 9502

6. At the same time the impedance matching unit Type 7949 makes the necessary change in the cavity tapping point to preserve an adequate match between the dynamic impedance of the loaded tuned circuit and the 70-ohm aerial feeder.

7. The control unit Type 7216 makes it possible for these operations to be carried out directly by the operator if the automatic system fails, or if operation is required at a frequency not included when the system was set up before flight.

Frequency coverage

8. The frequency band covered by the aerial system is the same as for the transmitter-receiver equipment, 2.8 to 18.1 Mc/s. This band is too great to be covered easily by a single variable capacitance which would give a very cramped frequency scale and make accurate tuning very difficult. Therefore the tuning unit capacitor is sub-divided into three variable and three fixed sections with one variable section permanently in circuit and the others brought in by a switching device according to the range selected.

Frequency ranges

9. A cam-operated switch gear is provided to enable the sections of the capacitor to be selected to give a total of six frequency ranges. There is a considerable amount of overlap in the frequency coverage of the various ranges; this factor is valuable in selecting the best working condition for a particular aircraft installation.

Impedance matching

10. In order to simplify the matching arrange-

ments, continuously variable tapping is not used and six preset tapping positions are provided by the impedance matching unit. The output connections of the tappings to the cavity may be commoned to provide two (or more) tappings as described in Chapter 7 of this Section.

DETAILED CIRCUIT DESCRIPTION

Introduction

11. The automatic and manual tuning of the aerial system is controlled by a relay panel in the selector unit Type 7003. A general summary of the function of the relays is given in Table 1. Reference should be made to the circuit in fig. 8.

Power supplies

12. All the control circuits and drive motors employed to bring about the tuning and switching processes are operated from the aircraft 28V DC supply. The supply enters the aerial system at plug 13AF of the selector unit (pin 17 negative and pin 18 positive—fig. 2).

13. A 3-amp fuse mounted on the front panel of the selector unit, is incorporated in the positive 28V line. No DC supply is present in the aerial system when the transmitter-receiver installation is switched off.

Functional sub-division of circuit

14. The circuit is described with reference to the operation of the aerial system and for simplicity the various sub-circuits are tabulated in Table 2 together with the main units involved and relays associated with the operation.

RESTRICTED

TABLE 1
Function of relays in aerial system Type 9502
(Selector unit Type 7003)

Relays	Circuit Description	Circuit Function
CSA, CSB	Channel selection	Relays CSA and CSB control the operation of the channel selector motor CSM which in turn controls the tuning of the aerial system according to the channel selected in the transmitter-receiver system.
NR	Number relay	Operated by channel number switching in transmitter-receiver system.
AMA, AMB	Auto-manual relays	Provide circuit conditions for either automatic or manual tuning according to position of AUTO/MAN switch on control unit Type 7216.
TL, TH	Tuning relays	These relays are arranged to drive the tuning motor TM in either direction to reach conditions of aerial resonance.
BR	Centre-stable relay forming part of Wheatstone servo system.	Selects tuning relays TL or TH to drive tuning motors in direction required to reach aerial resonance.
FTA, FTB	Fine tuning relays	Give conditions of fine tuning for manual operations or for fine adjustment after automatic tuning.
RR	Range relay	Operating range switch under motor RM for selection of range appropriate to channel selected at transmitter-receiver system.
MR	Matching relay	Operates matching motor MM for selection of impedance matching appropriate to channel selected at transmitter.
MS	Meter shunt relay	Changes meter shunts to give adequate readings under conditions of low power operations.

TABLE 2
Sub-circuit and relay operation

Circuit	Relays involved	Units involved
Channel selection (Auto) only	CSA, NR	Control unit Type 7216 Control unit Type 4190
Range selection (Manual)	AMB, RR MR	Control unit Type 7216 Selector unit Type 7003 Tuning unit Type 7016 Impedance matching unit Type 7949
Range selection (Auto)	AMB RR MR	Selector unit type 7003 Tuning unit Type 7016 Impedance matching unit Type 7949
Tuning (Manual)	AMA AMB TL TH	Control unit Type 7216 Selector unit Type 7003 Tuning unit Type 7016

RESTRICTED

TABLE 2 (continued)
Sub-circuit and relay operation

Circuit	Relays involved	Units involved
Tuning (Auto)	AMA AMB FTB TL TH	Selector unit Type 7003 Tuning unit Type 7016
Fine tuning (Auto) and (Manual)	AMA AMB FTA FTB TL TH	Control unit Type 7216 Selector unit Type 7003 Tuning unit Type 7016
Keying interlock	CSB RR MR AMA FTA TL TH	Control unit Type 7216 Control unit Type 4190 Selector unit Type 7003
(Tune) operation	AMA FTA TL TH	Control unit Type 4190 Selector unit Type 7003
Low power operation and RF monitoring	AMA FTA MS	Control unit Type 7216 Control unit Type 4190 Selector unit Type 7003 Tuning unit Type 7016

Procedure for tuning the aerial system

15. A knowledge of the tuning procedure for the aerial system is necessary for a complete understanding of the circuit description which follows it. The procedure is concerned only with the aerial system and should not be used for setting-up purposes. Full information on the setting-up and operation of the complete installation (ARI.5874) is given in Chap. 13 of this Section.

- (1) Switch on the installation by turning the power switch on the control unit Type 4189 to STANDBY (*Sect. 1*).
- (2) Set the control unit Type 7216 AUTO/MAN switch to AUTO. The SAFE lamp should glow.
- (3) Select the required channel at control unit Type 4189. The turret switch should come to rest with the correct channel letter showing in the correct aperture.
- (4) Set-up the transmitter and receiver for the channel selected (*Chap. 13*).
- (5) From the calibration chart, ascertain the aerial system tuning range(s) in which the desired frequency can be obtained. Where there are alternatives, the lowest range number should be used (there are some

exceptions—refer to *Chap. 13*). Range 6 must not be used for frequencies above 5 Mc/s. By means of a screwdriver, move the SET RANGE control of the selector unit to the desired range.

- (6) Ascertain from the calibration chart the approximate angular setting of the variable capacitor for the required frequency. Press the SERVO CHECK button on the selector unit and with a screwdriver rotate the TUNING control until the selector meter unit gives the reading obtained from the calibration chart. (The control is turned clockwise to increase the reading and vice-versa).
- (7) Turn the master switch on control unit Type 4189 to TX and operate the selector unit key to TUNE. With the SERVO CHECK buttons released, there should be a reading in the meter since it is now connected to the aerial indicator circuits to monitor radiation. Turn the TUNING control slowly in the direction which increases the reading until maximum is reached.
- (8) Move the selector unit key to TEST and check the effect of small re-adjustments in either direction. (As the keying interlock circuits are now in operation, the meter will not read

RESTRICTED

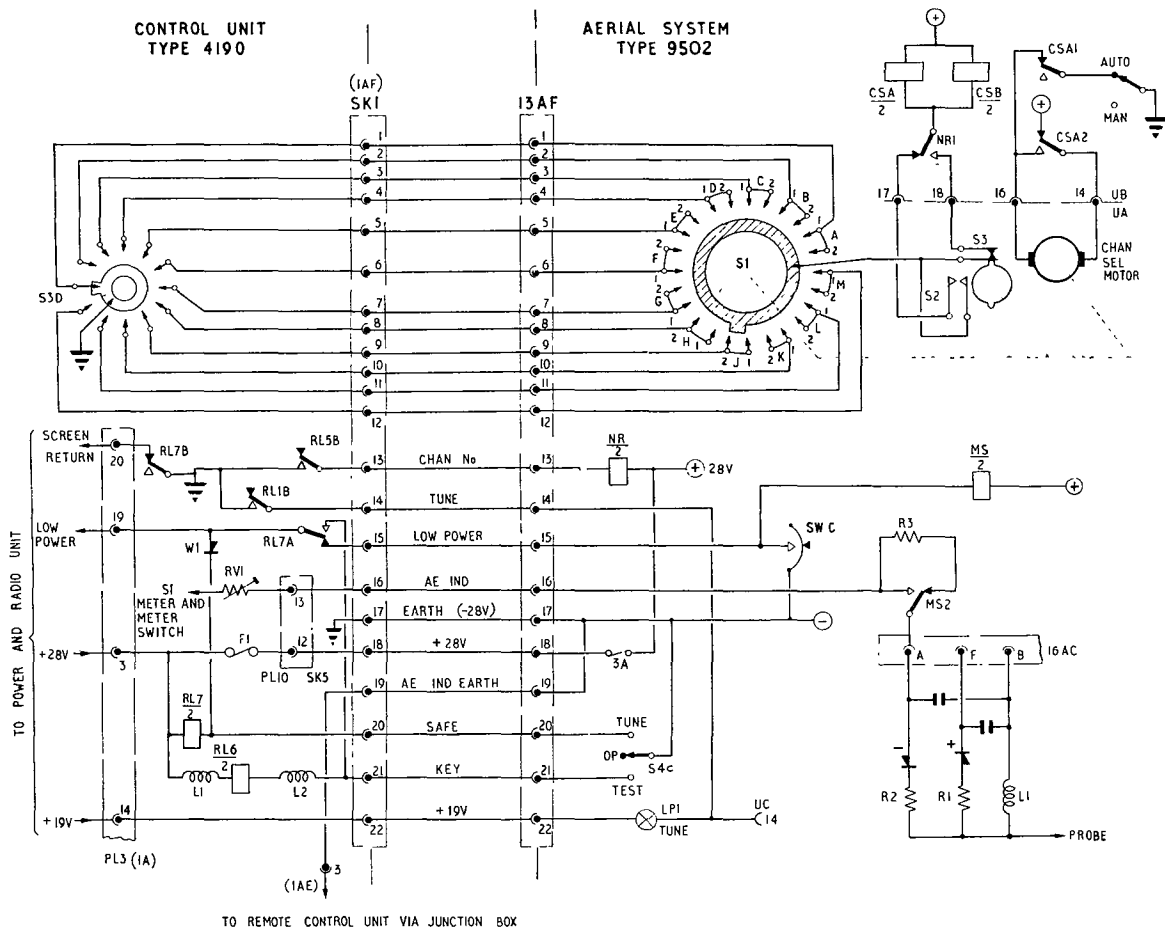

Fig. 2. Simplified connections between transmitter-receiver equipment and aerial system Type 9502

while the tuning motor is running.) When the maximum reading under these conditions is reached, tuning is complete.

16. Once this procedure has been carried out for each channel in use, the selection of a channel at control unit Type 4819 should cause the aerial system to tune to the channel frequency automatically. In practice, the servo system controlling the aerial tuning may not exactly reproduce the capacitor settings, though the error should not exceed one or two degrees even under the most unfavourable conditions.

17. Because of the relatively high "Q" of the aerial system however, this amount of mistuning may cause some loss of radiation. For this reason, the control unit Type 7216 has facilities for making small corrections to the tuning without the necessity of re-adjusting the selector unit.

18. If the COARSE/FINE switch on the control unit is set to FINE, the SHIFT FREQ. key can be used to directly operate the tuning motor (at reduced speed) and can, therefore, be employed to correct the tuning if it should appear necessary.

19. Under normal operating conditions, RF radiation is monitored by the meter in the control unit, which can therefore, be used to check that maximum output is being obtained.

Channel selection (AUTO only)

20. Under conditions of AUTO operation, the RANGE and TUNING servos are operated by pre-set controls in the turret assembly of the selector unit. The function of the channel selection circuits is merely to cause the rotation of the turret until it takes up the position bringing the SET RANGE and TUNING pre-set control appropriate to the selected channel into operation.

21. All the circuits necessary for carrying out this operation are contained in the mechanical drive unit Type 7333. The control circuits are designed to work in conformity with the method of channel identification used in the transmitter-receiver equipment, the channels being divided into two groups of twelve, each channel being designated by one of the letters A to M and the numbers 1 or 2 (Sect. 1).

22. The interconnection between the transmitter-receiver equipment and the aerial selector unit is

RESTRICTED

shown in the simplified diagram (fig. 2). The switch S1 controlling the position of the turret has 24 positions, the position sequence being 1A, 2A; 1B, 2B; 1C, 2C; and etc. The stator tags are strapped together in pairs, 1A and 2A, 1B and 2B etc.

23. One control line is brought out from each pair of stator tags and provides the "channel letter" control, the channel selection being made by switch S3D in the control unit Type 4190 (Sect. 1). The "channel number" control is provided by a pair of springsets S2 and S3.

24. A diagram specially devised to show the operation of the "channel letter" and "channel number" selection is given in fig. 3. The springsets S2 and S3 are operated by a specially designed cam in the drive unit. This cam makes six revolutions for each revolution of the switch spindle (S1) and has two pairs of "lifts" (shown as one cam with two "lifts" in the diagram). One "lift" is arranged to close the springset S2 twice per revolution of the cam, i.e. twelve times per revolution of the switch. The other "lift" operates springset S3 in a similar manner, but its operating positions are displaced 90 deg. from those of the springset S2.

25. Because of the 6 to 1 gearing between the camshaft and the switch shaft, the latter moves 30 deg. between any two consecutive closures of S2 or S3, but only 15 deg. between any closure of S2 and the next closure of S3 and vice versa. Since the 24 positions of switch S1 are at 15 deg. intervals, it follows that springset S2 is closed when S1 is in any of the positions 1A, 1B, 1C etc. Springset S3 will be closed in the intermediate positions 2A, 2B, 2C, etc.

26. The operation is illustrated in the two conditions "channel 1A selected" and "channel 2A selected" in fig. 3. (The black and white arrows shown on S1 and the springset cam are for illustration purposes only).

27. From the above, it follows that "channel number" selection is merely a matter of selecting the circuit containing either springset S2 or S3; the choice is made by the "channel number" relay NR/2 (contact NR1).

28. Suppose that channel 1A is selected at the remote control unit of the transmitter-receiver equipment, with the (aerial) control unit Type 7216 set to AUTO. The

channel selection mechanism of the control unit Type 4190 will operate first; when it comes to rest the switch 1S3D connects DC negative to pin 1 of plug 13AF (fig. 2), since the "channel number" is "1", pin 13 is isolated by the open relay contact 1RL5B and relay NR/2 is not operated.

29. Assuming that switch S1 is in some position other than "A" its rotor will be isolated from DC negative and relays CSA and CSB will be unenergized regardless of the operating condition of the springsets S2 and S3. The channel selector motor CSM has therefore a connection to the 28V DC positive supply line via contact CSA2 and to the DC negative line (via contact CSA1 and the AUTO/MAN switch in the control unit Type 7216).

30. In the assumed conditions the motor CSM will run, driving the turret assembly until the rotor of switch S1 in the drive unit comes to position 1A. The rotor of S1 is then connected to DC negative via pin 1 of plug 13AF and as soon as the springset S2 closes (fig. 3) relays CSA

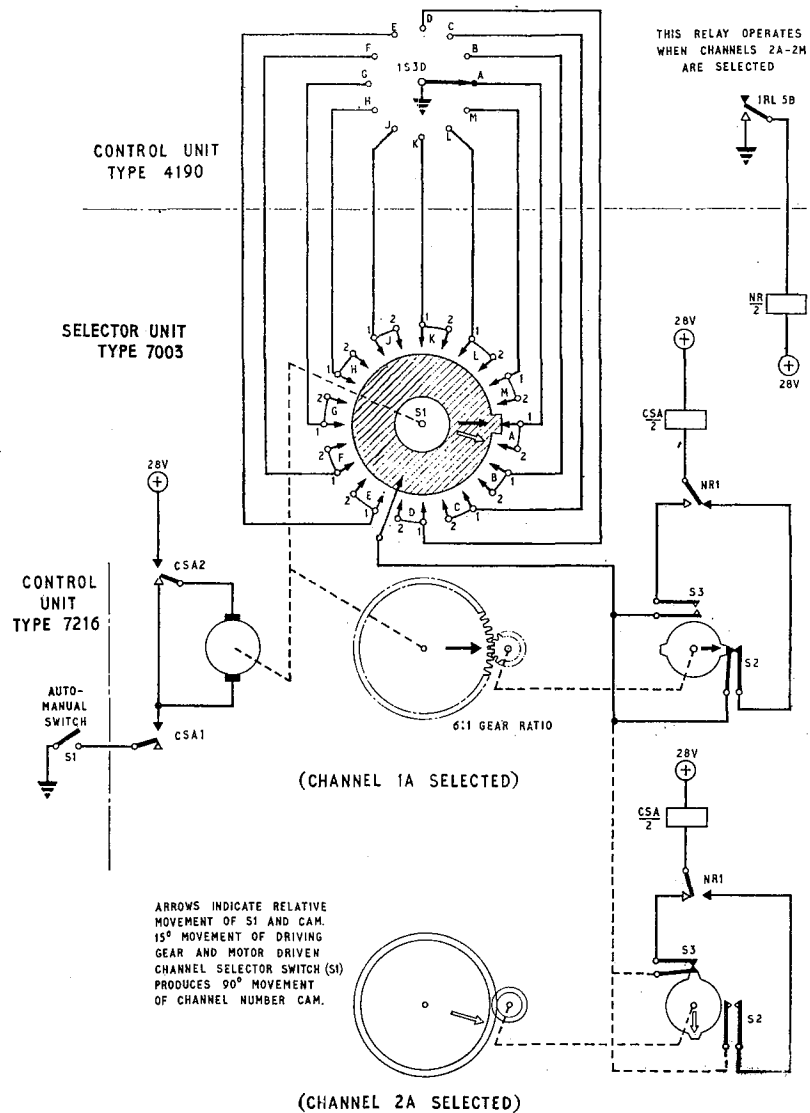

Fig. 3. Operation of channel "letter" and "number" selection on rotating turret

RESTRICTED

and CSB are operated via relay contact NR1, S2, S1 (contact 1A) and contact A of switch 1S3D.

31. Relay contact CSA1 breaks the motor supply circuit and CSA2 short-circuits the motor armature to produce rapid braking. Contact CSB1 closes and completes the energizing circuit of the AUTO/MAN relays AMA and AMB; these relays connect the selected preset controls into the servo circuits (fig. 4).

32. Suppose now that channel 2A is selected at the remote control unit (fig. 2). Line 13 of plug 13AF will be connected to DC negative via the closed relay contact 1RL5B and the number relay NR energized. In this case, rotation of the turret will continue until switch position 2A is reached (S1).

33. The rotor of S1 remains connected to line 1 of 13AF, because the switch positions 1A and 2A are strapped together, but because relay NR is energized, the relays CSA and CSB will not be energized until springset S3 is closed (fig. 3). Thus the turret revolves a further 15 deg. before coming to rest, thereby bringing a fresh pair of preset controls into the operating position.

34. Once the turret is at rest, range selection and tuning commence as described in para. 54 and 75.

Precaution against failure of automatic channel selection

35. It should be noted that since the contacts of relays CSA and CSB are "operated" when the relay coils are unenergized, failure at any point in the coil circuit will prevent "AUTO" operation. If CSA fails to energize, the motor CSM will run continuously. If CSB fails, the AUTO/MAN relays cannot operate and it will not be possible to key the transmitter because contact CSB1 will permanently close the TUNE line (fig. 4).

36. Because of this possible failure it is arranged that switching to MANUAL on the control unit Type 7216 breaks the DC negative connection to contacts CSA1 and CSB1 (fig. 2 and 3) so that in the event of such failure, operation is still possible under MANUAL control.

37. With such conditions it will still be possible to effect automatic channel selection of the transmitter-receiver equipment from the remote control unit but the aerial system must be tuned to resonance for each channel by means of the control unit Type 7216.

Range selection (MANUAL)

38. With the AUTO/MAN switch S1 of the control unit Type 7216 in the MANUAL position, the DC negative line (pin N of plug 14AA) is connected via the switch to the moving contact of the manual RANGE switch S3 (fig. 4 and 8).

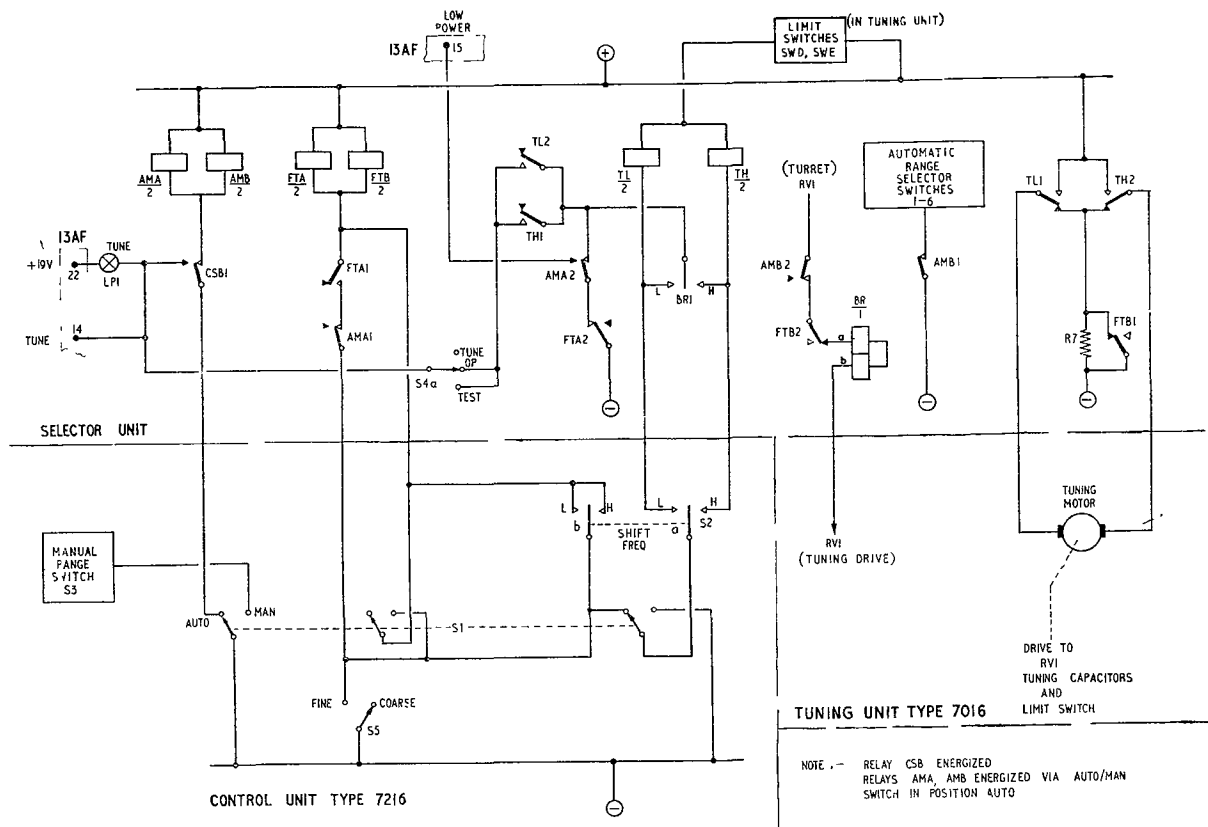

Fig. 4. Simplified circuit of AUTO/MAN tuning and fine tuning relays

RESTRICTED

39. Operation of the manual RANGE switch enables the DC negative line to be applied to any one (selected) of the six "range" lines. These lines pass via the selector unit Type 7003 to the tuning unit Type 7016, where they terminate on the six points of switch SWA (fig. 8).

40. Unless this switch is in such a position that it isolates the "range" line selected, the DC negative line is taken back via a seventh connection on this switch to "range" relay RR in the selector unit (relay unit Types 7332). In these circuit conditions the relay will operate thus completing the 28V DC supply circuit for the "range" motor via contact RR2 (fig. 5).

41. The range motor drives the "range" selection switches SWF of the tuning unit until the selected contact of SWA is isolated by entering the gap in the rotor. In this position the DC negative line to relay RR is broken, the relay releases and its contacts "RR" remove supplies to the motor RM and short-circuits the motor armature to provide rapid braking.

Special DC negative connection of range motor

42. Under normal operating conditions the "range" motor is returned to DC negative by virtue of its connection to the tuning unit chassis (fig. 8). This method of connection is necessary because the three ceramic seals used to convey connections through the pressurized canister can take only 24 of the necessary 25 connections to the 25-way plug PL1.

43. Provision is made for testing the tuning unit chassis when it is removed from its canister by the use of a special harness which includes a connection to pin C of the plug PL1.

Range and impedance matching

44. A shaft driven by the range motor operates switches SWF to connect the appropriate variable and fixed capacitor sections for the range selected.

45. The range motor also drives the ganged switches SWAa and SWAb (para. 41). When the switch sector SWAb comes to rest it provides a DC negative connection to one of six lines used to control the impedance matching unit (line 4 is shown selected in fig. 8). These six lines terminate at switch SW1 of the impedance matching unit which is used to control the position of the cavity tapping switches SW2 and with which it is ganged. Both switches are driven by the matching motor in the impedance matching unit.

Cavity tapping switch

46. The taps on the wall of the cavity are connected

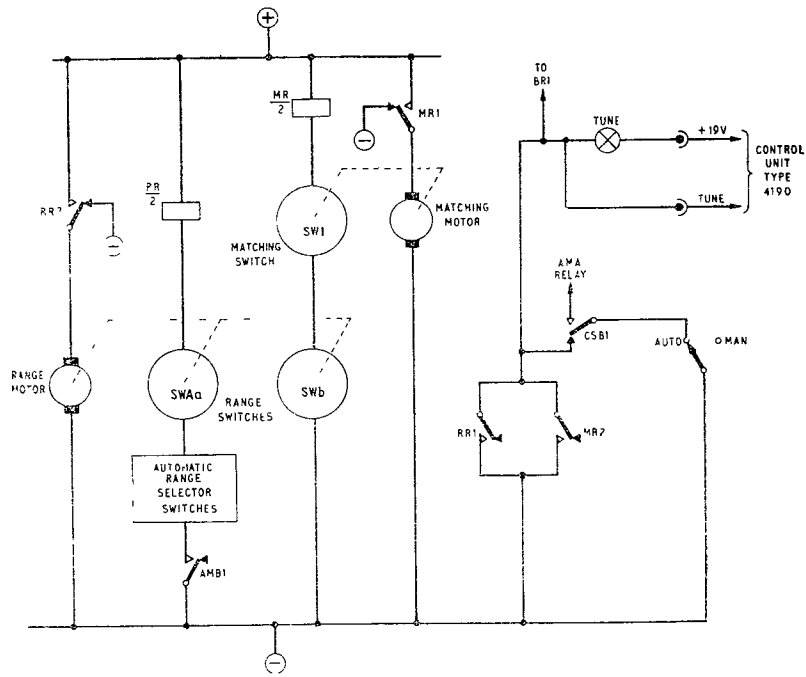

Fig. 5. Simplified circuit of range and matching relays

via the tinned copper straps to the tapping switch SW2. The numbers on the cavity taps are related to those of the range switches SWAb in the aerial tuning unit.

47. The switch SW2, which is driven by the matching motor and is on the same shaft as the line-finder switch SW1 connects the selected tap to the transmitter feeder via the coaxial plug PL3.

48. Six switch positions are available; the wiring to the tag panel being arranged to bring the switches into the same position for ranges 5 and 6.

Note . . .

The tappings shown in fig. 8 and 9 are for particular aircraft. It is probable that a varying number of taps will be used in other types of aircraft fitted with this suppressed aerial system.

Probe circuit

49. The probe is connected by means of a screened lead to the coaxial socket PL2 and thence to a tapping on the cavity. The internal connection is made at the junction of R1, R2 and L1, where the pick-up from the probe is rectified to give a positive and negative output via pins F and A respectively, of the 12-way plug PL1. The outputs are used to give RF output indications on meters in the control unit Type 7216, selector unit Type 7003 and control unit Type 4190 (Sect. 1). The probe connection on the Valiant includes a 150-ohm resistor to reduce the pick-up to a practical level. ▶

50. In the impedance matching unit, the DC negative connection is taken from the line selected by the tuning unit switch SWAb via switch SW1 to the matching relay MR in the selector unit (relay unit Type 7332). Relay MR operates and its

RESTRICTED

contacts MR1 connect the 28V DC supply to the matching motor which then drives the switches SW1 and SW2 until the selected line is isolated as a result of its contact on SW1 entering one of the two rotor gaps and thereby releasing relay MR. Contacts MR1 disconnect the motor supply and short-circuit the armature to provide rapid braking.

51. As long as the range or matching motors are running, that is with relays RR or MR operated, contacts RR1 and MR2 connect the TUNE line (plug AF, pin 14) to DC negative. This prevents keying of the transmitter until range selection is complete (para. 104).

52. During MANUAL operation, the AUTO range selection springset RSS1 to 6 in the selector unit are prevented from influencing the selection by means of relay contact AMB1 which isolates them from the DC negative line.

53. Regardless of the state of relay CSB, relay AMB will be released during MANUAL operation, because in this condition the DC negative connection of pin 2 of plug 13AA is broken by the AUTO/MAN switch in control unit type 7216.

Range selection (AUTO)

54. When the AUTO/MAN switch on the control unit Type 7216 is in the AUTO position the DC negative line is disconnected from the manual range switch S3 which is therefore ineffective.

55. Assuming the selector unit turret to be at rest, relay CSB will be operated and consequently the DC negative line connection present at pin 2 of plug 13AA (via S1) is extended by contact CSB1 to relays AMA and AMB both of which will operate (fig. 4 and 8).

56. Relay contacts AMB1 provide a DC negative connection to the springsets RSS on the selector unit. One of the six contacts will be closed according to the position of the selected cam in the turret assembly (fig. 8). Therefore one of the six range lines will be connected to DC negative and range selection will proceed until this line is isolated. The impedance matching unit which is controlled from the tuning unit range selection system will also operate exactly as described for manual range selection in para. 38 to 53.

Tuning (MANUAL)

57. Under the above heading "coarse" tuning only will be considered. The fine tuning arrangements are discussed in para. 101 to 109.

58. The AUTO/MAN switch in the control unit 7216 being in the MANUAL position, pole "a" of the SHIFT FREQ. switch key S2 is connected to DC negative. Operation of this key to the "L" position provides a negative connection to the "tune low" relay TL (fig. 4). Provided the rotors of the tuning capacitors C1 to C4 are not in the "fully meshed" condition, relay TL has connection to the 28V DC positive line through the limit springset SWD and SWE in the tuning unit (fig. 6).

59. The operation of relay TL moves the contacts TL1 to connect the DC positive line to pin T of plug 15AB of the tuning unit whence it is fed to one terminal of the tuning motor (fig. 8). The other terminal of the motor is returned via pin U of 15AB to the "released" contacts TH2 of relay TH and thence via the "released" relay contacts FTB1 to DC negative.

60. Since the tuning motor is a permanent magnet type, its direction of rotation is determined by the polarity of the supply connections and it is arranged that under this condition it drives the variable capacitor vanes into greater mesh.

61. This rotation continues as long as the SHIFT FREQ. switch is held in position "L", unless motion is arrested by the rotors reaching full mesh, in which case a striker on one of the capacitor rotors closes springset SWEa (fig. 6). The operation of springset SWEb causes the LIMIT lamp in the control unit to glow and immediately afterwards springset S1b is operated, thus breaking the DC positive connection to relay TL.

62. When relay TL releases, contacts TL1, in conjunction with contacts TH2, short-circuit the armature of motor TM, providing rapid braking.

63. If the SHIFT FREQ. key is moved to position

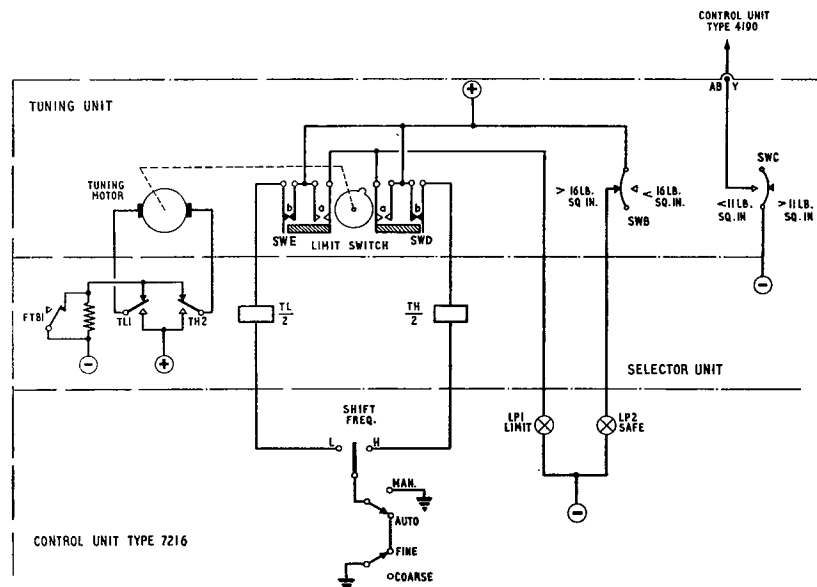

Fig. 6. Simplified limit, safe and low power circuits

RESTRICTED

"H", the "tune high" relay TH (*fig. 4*) is operated in a similar manner to that described for relay TL (*para. 58*). The contacts TH2 connect the DC positive line to pin U of plug 15AB (*fig. 8*) and thence to the tuning motor. Pin T of 15AB is returned to DC negative via the "released" contacts TL1 and FTB1.

64. The polarity of the tuning motor connection is, therefore, opposite to that for the circuit conditions when relay TL is operated and the direction of rotation will be such as to drive the variable capacitor in the direction of decreasing mesh.

65. The rotation of the tuning motor in this direction will continue until either the SHIFT FREQ. switch is released or the variable capacitor reaches its fully "unmeshed" condition.

66. In the second event the striker referred to above (*para. 61*) first closes springset SWDa, causing the LIMIT lamp to glow, and then opens springset SWDb, breaking the DC positive connection to relay TH. The tuning motor is thus short-circuited to provide rapid braking when both TL1 and TH2 are in the "released" condition.

67. Since relay AMA is "released" during MANUAL operation contacts TH1, TL2 and BR1 are isolated from DC negative and have no effect (*fig. 4*). During COARSE tuning however, the fine tuning relay FTA is also "released" and a DC negative connection exists via contacts FTA2 and AMA2 to the meter shunt relay MS (*fig. 8*) and via pin 15 of the plug 13AF to the "low power" circuits of the transmitter (through control unit Type 4190).

68. Thus during COARSE tuning, the transmitter can be operated only in the "low power" condition and the shunts of the RF monitoring meters are selected by relay MS to give an adequate reading for this low power condition. The reason for this arrangement is that if the transmitter key is held down during tuning, conditions of severe mismatch may occur with consequent overload of the transmitter PA circuits.

69. Since it is necessary to key the transmitter in order that the approach of the tuned circuit to resonance may be observed by the operator, it is arranged for the transmitter to be operated at low power. Once the operator is satisfied that the tuned circuit is near resonance, he can switch to FINE tuning. The fine tuning relay FTA will then operate, thus releasing relay MS and the "low power" relay in the transmitter circuits so that final tuning adjustments can be made under full power conditions.

70. The potentiometer RV1 in the tuning unit is ganged to the variable capacitor and forms part of the Wheatstone bridge servo system used for AUTO tuning (*fig. 8*). During MANUAL operation RV1 is left in circuit and a connection is brought from its wiper via a 27K ohm resistor R2 in the selector unit to pin P of the control unit Type 7216.

71. A monitoring meter in the control unit is connected to the wiper of RV1 by pressing the button of the SERVO CHECK switch S4 (*fig. 7*). The meter has a 1mA movement and the arrangement is effectively a voltmeter having a f.s.d. of about 27 volts, so connected as to measure the p.d. between the wiper of RV1 and DC negative.

72. Since this p.d. is dependent on the position of the wiper, it can be used as an indication of the position of the capacitor rotors. To this end the meter is provided with a scale calibrated from 0-180 deg. The fully-meshed (lowest frequency) position of the capacitor is taken as 0 deg. and the completely unmeshed (highest frequency) position as 180 deg.

73. Thus by pressing the SERVO CHECK button, the operator can check the capacitor position and also verify that the SHIFT FREQ. key is operating correctly. When the key is moved to "H" the meter reading should increase whereas movement to "L" should cause a reduction to take place.

74. It should be noted that the scale calibration in degrees is not intended to be exact and no attempt has been made to compensate for supply variations. However, it is accurate enough to be used in conjunction with the calibration chart (*para. 15*) to indicate at what point in the capacitor travel the operator should begin to explore for resonance at any given frequency.

Tuning (AUTO)

75. When the AUTO/MAN switch on the control unit Type 7216 (*fig. 4 and 8*) is in the AUTO position, there is no DC negative connection to the poles of the SHIFT FREQ. key S2 unless the FINE/COARSE switch S5 is in the FINE position. Under conditions of COARSE tuning, therefore, the SHIFT FREQ. key is inoperative.

76. Assuming the turret to be at rest, relays CSA and CSB will be operated and consequently relays AMA and AMB are energized via CSB1 and the AUTO/MAN switch (*fig. 4*). The fine tuning relays FTA and FTB are both "released" (since the FINE/COARSE switch is in the COARSE position), and therefore a DC negative connection is made via contacts FTA2 and AMA2 to the moving pole BR1 of the centre-stable relay BR.

77. Since relay AMB is operated and relay FTB released, the coil of the centre-stable relay BR is connected on one side via brush B1 to the wiper assembly of the turret in the selector unit and on the other side direct to the wiper of the tuning unit potentiometer RV1. This potentiometer and the associated resistor RV1 adjacent to the selector unit turret are connected directly across the 28V DC supply so as to form a Wheatstone bridge arrangement with the centre-stable relay occupying the "galvanometer" position.

78. The turret assembly carries 24 independently adjustable wipers (one per channel) and whichever is in contact with resistor RV1 can be adjusted by rotating its lead screw through an access hole in the selector unit front panel.

RESTRICTED

79. The potential at terminal "a" of relay BR thus depends on the point at which the wiper in use makes contact with resistor RV1 adjacent to the selector unit turret. While that of terminal "b" is that of the wiper of the potentiometer RV1 ganged to the variable capacitor assembly in the tuning unit.

80. Any difference of potential between these two points will give rise to a current through the coils of relay BR and since this is a centre-stable relay, the direction of movement of its moving contact will depend on the direction of the current in the coil. The relay may, in fact, be regarded as a "centre-zero" galvanometer, with its scale replaced by two fixed contacts. The sensitivity is similar to that of a galvanometer, a current of about $75\mu\text{A}$ being sufficient to operate it.

81. The connections of relay BR are so arranged that it closes on the contact marked "H" when the potential of coil terminal "a" is higher than that of terminal "b" and on terminal "L" if the reverse is the case.

82. To prevent possible inductive surges from burning the delicate contacts BR1, spark quenching arrangements each consisting of a rectifier and resistance (MR1, R8; MR2, R9) are connected across the coils of relays TL and TH, respectively (fig. 8).

83. The functioning of the AUTO tuning arrangements can be most easily understood by a description of the "setting up" which follows in para. 84 to 91.

84. On the front panel of the selector unit there is a SERVO CHECK push button PB1 (fig. 8). Pressure on this causes the meter (also on the front panel) to be connected via the 27K resistor R1 to brush B1 which is in contact with the turret.

85. As in the case of the control unit Type 7216, the meter is a 1 mA type and the arrangement again forms a voltmeter with an f.s.d. of about 27 volts connected in this case so as to read the p.d. between the turret frame and DC negative. As stated earlier (para. 72) this potential is determined by the position of the wiper in use on the associated resistor RV1.

86. The meter on the selector unit is provided with a degree scale identical with that in the control unit and this indicates the position which the capacitor *will have taken up when the system comes to rest.*

87. Assume that the system is at rest with the variable capacitor set at 60 deg., and it is now desired to set the capacitor to 110 deg. with the SERVO CHECK button pressed, the operator moves the wiper in use by means of its lead-screw (turning clockwise to increase the setting) until the meter reads 110 deg.

88. The potential of terminal "a" of relay BR is now higher than that of terminal "b" and BR1 therefore operates on its "H" contact, causing relay TH to be operated from the DC negative line via contact AMA2 and FTA2 (fig. 4). The tuning motor starts to drive the variable capacitor in the direction of *frequency increasing* (towards 180 deg.).

89. The potential at terminal "b" of relay BR rises until the point is reached (at a capacitor setting of very nearly 110 deg.) when the p.d. is insufficient to hold the contacts closed, so that they open and release relay TH.

90. Although braking is applied by short circuiting the armature of the tuning motor, the inertia of the system is generally enough to carry the capacitor past the desired position. Consequently, the potential at terminal "b" of relay BR now becomes higher than that at terminal "a" to an extent sufficient to cause contact BR1 to close on its "L" contact and thus operate relay TL.

91. This causes the tuning motor to run in the opposite direction and returns the system towards the desired position once more. Again, although relay BR will release and thus release relay TL slightly before the correct position is reached, it would be possible for inertia to carry the system far enough beyond the correct position to operate relay TH once more.

Mechanical "anti-hunt" device

92. Unless precautions were taken to prevent it, this oscillation or "hunting" about the desired position could continue indefinitely. In this system an "anti-hunt" device is fitted to the aerial tuning unit gearbox.

93. Interposed between the final shaft of the main driving train and the variable capacitor rotor shaft is a 9 : 1 friction epicyclic gearbox. The input and output shafts of this gearbox are concentric and are additionally provided with a pin and slot coupling. For the greater part of any capacitor movement, the drive between the main train and the capacitor rotors is transmitted by contact between the pin on the input shaft and one edge of the slot on the output shaft. The ratio is thus 1 : 1 and the friction drive merely slips.

94. Whenever the direction of drive is reversed, however, as in the case of an overshoot, the driving pin moves out of engagement with the slot and the only connection between the input and output shafts is via the 9 : 1 friction gear. Hence the rotors are driven over a small arc (about 5 deg.), until the pin engages the opposite face of the slot and the 1 : 1 drive is restored.

95. By this means it is ensured that once the system has made one overshoot past the desired position, it will return towards it so slowly that further overshoots are prevented and "hunting" does not occur.

RESTRICTED

96. When it is required to adjust any particular channel to a lower frequency than its existing setting, the lead screw is turned counter-clockwise, thereby causing the wiper in use to travel towards the low potential end of the selector unit resistor RV1.

97. Thus the potential of terminal "a" of relay BR falls below that of terminal "b" contact BR1 closes on its "L" contact, and relay TL is operated. The tuning motor consequently starts to drive the variable capacitor into close mesh and the ganged wiper of the tuning unit potentiometer RV1 travels towards its low potential end until the p.d. across relay BR disappears, opening the "L" contact and releasing relay.

98. As in the previous case an initial overshoot may occur but hunting is prevented by the arrangement already described (*para.* 92). Thus the position taken up by the capacitor during AUTO tuning is governed entirely by the point of contact of the turret wiper which is brought into the operating position.

99. One wiper is provided for each of the 24 channels and the wiper associated with the selected channel in the transmitter-receiver system is brought into mesh by rotation of the turret under control of the channel selection circuits.

100. During the setting-up operation it is essential that the operator should be able to key the transmitter and observe the approach of the system to resonance. The facility is provided by the key switch S4 on the selector unit front panel which is moved to the TUNE position. This breaks the DC negative connection to the TUNE line which is otherwise made via FTA2, AMA2, TL2, or TH1 and S4a, thus enabling the key circuits to operate (*fig.* 4). At the same time the transmitter power is slightly reduced to prevent overloading whilst tuning is taking place (*para.* 110).

Fine tuning (AUTO and MANUAL)

101. The fine tuning arrangement during either AUTO or MANUAL operation is designed to permit fine adjustments to tuning whilst the transmitter is being keyed at full power. The fine tuning condition is brought about in either case by the operation of the two FINE TUNE relays FTA and FTB (*fig.* 4).

102. During AUTO operation the operator may suspect for some reason that the aerial system is slightly detuned (this condition will be evidenced by a "lower-than-normal" reading of the monitoring meters). The operator therefore moves the control switch S5 to the FINE position (*fig.* 4) which, since S1 is in the AUTO position, provides a DC negative connection to both poles of the SHIFT FREQ. key S2.

103. Immediately the SHIFT FREQ. key is operated, its pole "b" connects the DC negative line to operate relays FTA and FTB. During AUTO operation relay AMA is operated (*para.* 71) and once the FINE TUNING relays are operated the

circuit is held by the DC negative connection provided via FTA1, AMA1 and S5.

104. Relay contact FTA2 removes the DC negative connection previously existing via FTA2 and AMA2 (AMA2 is "operated") to contacts BR1, TH1 and TL2. Contacts BR1, therefore, can no longer control the tuning relays TL and TH but these can be operated by means of the SHIFT FREQ. key since there is now a DC negative connection to S2a via S5 and S1. It is thus possible for the operator, by movement of the SHIFT FREQ. key to positions "L" or "H" as desired, to energize relays TL or TH, respectively, and so run the tuning motor in either direction.

105. Because contacts TL2 and TH1 have been isolated from DC negative by FTA2, they can no longer operate the TUNE circuit and thus interrupt keying (*fig.* 4). The operator is therefore able to key the transmitter continuously and observe the effect of his adjustments by means of the monitoring arrangements.

106. Relay FTB is employed to reduce the speed of the tuning motor during FINE tuning by means of contact FTB1 which introduces the 68-ohm resistor R7 into the motor negative line. Contact FTB2 open-circuits the centre-stable relay BR to protect its coil from the possibility of large steady currents which could arise if the required re-tuning unbalanced the Wheatstone bridge circuit to any great extent.

107. As a precaution against the possibility of the AUTO tuning system remaining inoperative on the selection of a fresh channel, it is arranged that relay AMA is released during channel selection. The release contact of AMA1 releases the fine tuning relays FTA and FTB, thus returning the system to normal. This precaution is taken against the possibility of the operator failing to return the FINE/COARSE switch to the COARSE position. The relays FTA and FTB will remain released until operated again by further use of the SHIFT FREQ. key.

108. The circuit difference between AUTO and MANUAL fine tuning result from the fact that relay AMA is *not* operated for MANUAL operation. With S1 in the MANUAL position (*fig.* 4), relays FTA and FTB operate via S5 and S1 when S5 is switched to FINE and remain operated until it is returned to COARSE.

109. Contacts BR1, TL2 and TH1 are already isolated by contact AMA2, which is released, but FTA2 is now employed to remove the DC negative connection from the LOW POWER line (plug 13AF, pin 15—*fig.* 8) so that FULL POWER operation is possible. Direct control of tuning at *low speed* is, therefore, again available at the SHIFT FREQ. switch key and continuous monitoring can be carried out with the transmitter keyed at full power.

Keying (tune) interlock

110. To protect the transmitter and to avoid

RESTRICTED

arcing of switch and relay contacts, control circuits are provided to prevent accidental keying of the transmitter whilst channel changing operations are in progress. This protection is provided by the TUNE line of the installation which enters the aerial system at pin 14 of plug 13AF on the selector unit (*fig. 4*).

111. A connection to DC negative at any point on this line operates protective circuits in the transmitter installation which prevent keying of the transmitter. Such a connection is provided by contacts CSB1 of channel selection relay CSB during channel selection and by contacts RR1 (*fig. 8*) of range relay RR and MR2 of matching relay MR during range selection.

112. During AUTO operation, the TUNE line is also connected to DC negative via FTA2, AMA2, TH1 and TL2 and switch S4a in either the OPERATE or TEST positions.

113. Thus under normal operating conditions the transmitter cannot be keyed until channel selection, range selection and tuning are complete. In order to simplify the process of adjusting the aerial system to resonance, however, provision has been made for the transmitter to be keyed while tuning only is taking place, providing that adequate protection of the transmitter has been afforded in some other way. The special conditions are described under the headings which follow (*para. 114 to 118*).

MANUAL operation

114. In conditions for MANUAL operation, the aerial system channel selection cannot function because switch S1 on control unit Type 7216 has removed the DC negative connection from pin 1 to 13AA on the selector unit (*fig. 8*). Contact CSB1 is rendered inoperative by the same switch which disconnects DC negative from pin 2 of 13AA.

115. During COARSE tuning; i.e. whilst the operator is searching rapidly through the capacitor sweep for the required setting; the LOW POWER line (pin 15 of 13AF) is connected to DC negative via FTA2 and AMA2 and the transmitter is caused to operate at LOW POWER (*fig. 4*). This gives adequate protection of the transmitter and contacts TH1 and TL2 can be safely isolated by AMA2 to permit the transmitter to be keyed continuously whilst searching.

116. Once the required setting has been located, the operator moves the FINE/COARSE switch to the FINE position for accurate adjustment. Relay FTA is thus operated and its contact FTA2 removes the DC negative connection from the LOW POWER line. The transmitter can then be keyed at full power. This is permissible because the load on the transmitter at this stage is close enough to the correct value to dispense with the need for protection. Relay AMA remains released and contacts TH1 and TL2 therefore do not operate the protective arrangements.

AUTO operation

117. If during AUTO operation it is required to make re-adjustments of tuning, the facility is provided by the FINE position of the FINE/COARSE switch in conjunction with the SHIFT FREQ. key. In these conditions, although relay AMA is operated, contacts TH1 and TL2 are isolated because FTA2 is operated and the readjustments can thus be made with the transmitter operating at full power.

Setting up

118. During the setting up of channels, the TUNE/TEST switch S4a (*fig. 4*) of the selector unit is arranged to isolate contacts TH1 and TL2 from the protective circuits when the switch is in the TUNE position. This enables the preset controls to be set up with the transmitter keyed continuously; protection being afforded in this case by the introduction of resistance in the screen feed of the transmitter power amplifiers.

TEST lamp circuit

119. The TUNE lamp in the selector unit remains illuminated whilst the protective circuits are preventing transmitter keying. It is returned to the 19V positive line at pin 22 of plug 13AF (*fig. 4 and 8*) and is thus the only component in the aerial system which is not operated from the 28V supply.

120. This arrangement is necessary because the whole of the protective system in the transmitter installation operates from the 19V supply and the use of the 28V supply for the TUNE lamp in the selector unit would have produced an undesirable connection between the two supply voltages.

121. It should be noted that while the TUNE lamp should always be illuminated during channel or range selection, it should *not* in any circumstances be illuminated during MANUAL tuning or during FINE tuning. This arrangement provides a convenient means of checking for sticking of the centre-stable relay BR.

122. Under all conditions, *except* in normal AUTO operation, contacts TH1 and TL2 will be isolated from DC negative either because AMA2 is released or FTA2 is operated. Suppose, however, that contact BR1 has stuck on its "L" contact. Then as soon as the control unit SHIFT FREQ. key is moved to "L", the DC negative connection provided to relay TL will be extended via BR1 and, TL2 (TL2 will be operated) to the TUNE line and the selector unit TUNE lamp will be illuminated.

123. A similar state will arise on moving the SHIFT FREQ. key to "H" should BR1 stick on its "H" contact, so that this particular false operation of the TUNE lamp provides a direct check for sticking of the centre-stable relay.

TUNE operation

124. The TUNE/TEST key S4 in the selector unit (*fig. 8*) is provided to facilitate the setting up operation. In its normal OPERATE position, S4b connects the RF monitoring circuits to the meter in control unit Type 7216 (*fig. 7*). In either the

RESTRICTED

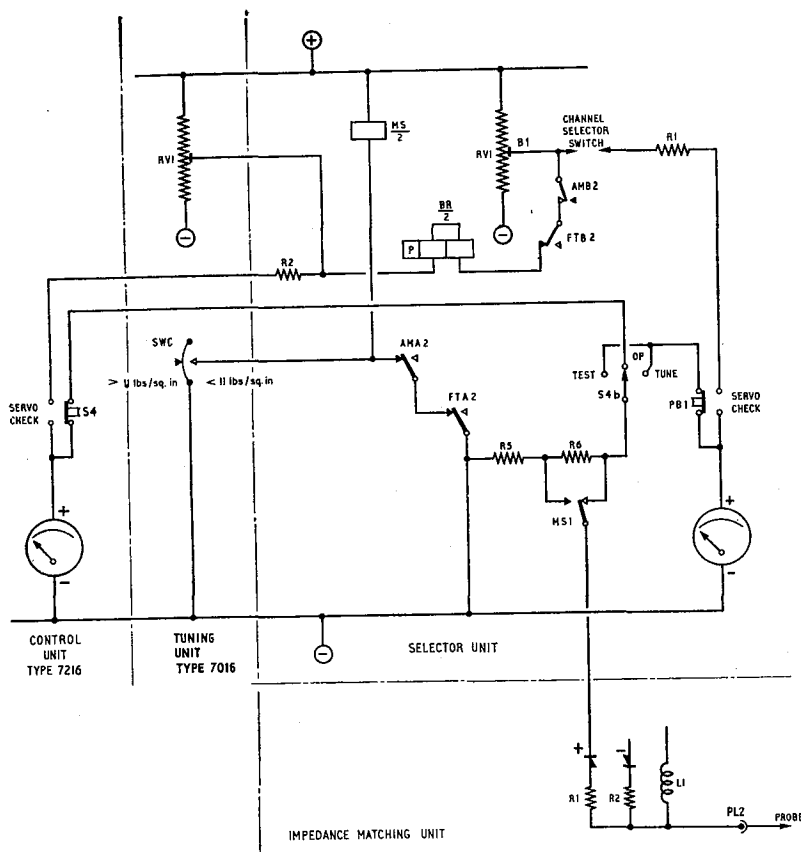

Fig. 7. Simplified circuit of RF monitoring and servo check device

TUNE or TEST positions the RF monitoring circuits are connected to the meter of the selector unit, so that the entire operation of setting up may be carried out from this unit.

125. The TUNE position of the S4 is arranged to key the transmitter under conditions of slightly reduced power output. This protects the transmitter against possible overloading and it is, therefore, permissible to set up the aerial tuning under "key down" conditions, thus making it possible to watch the meter continuously while adjusting to resonance.

126. Contacts TH1 and TL2 do not operate the TUNE line under the condition, because they are isolated by S4a (fig. 4). Switch section S4c (fig. 2) at the same time provides a DC negative connection for the SAFE line (pin 20 of 13AF). This enters the control unit Type 4190 (Sect. 1, Chap. 3) at pin 20 of socket 1AF (fig. 2 of this Chapter) and operates relay 1RL7.

127. Contact 1RL7B isolates the earthy end of the transmitter P.A. screen potentiometer consisting of 3R43 and 3R51 in the power and radio unit (Sect. 1, Chap. 5, fig. 7). Contact 1RL7A (fig. 2 of this Chapter) operates relay 3RL11 (shown in Sect. 1, Chap. 5, fig. 7) through rectifier 1W1 (fig. 2 of this Chapter) and the KEY line (pin 21—13AF); the effect of the operation of contact 3RL11A (Sect. 1, Chap. 5, fig. 7) is merely to

introduce R43 as a protective series resistance in the P.A. screen feed.

128. As a consequence of the above circuit conditions the transmitter will be keyed at *slight reduced* power as long as switch S4 is held in the TUNE position.

129. Having adjusted the aerial system to resonance in this way, the setting may be checked at full power by switching S4 to TEST. This operates the KEY line direct but since it re-connects contacts TH1 and TL2 to the TUNE line, the normal protective circuits operate. It is therefore necessary to allow the capacitor drive motor to stop after each small adjustment before the transmitter can be keyed.

Low power operation and RF monitoring

130. Facilities are provided in the transmitter installation for operation at approximately $\frac{1}{3}$ th power for short range communication. This condition is brought about under normal conditions by "earthing" the LOW POWER line at pin 6 of the intercom. socket 3SK5 on the power and radio unit (Sect. 1).

131. The earth at this point causes relay 3RL11 to operate, and the screen feed of the transmitter P.A. is transferred to the junction of resistors 3R43 and 3R51. Although the LOW POWER line also extends into the control and drive unit (pin 19 of 3PL3), the earth is prevented from operating relay 1RL7 of that unit by rectifier 1W1 (fig. 2).

132. Relay contact 1RL7B earths resistor R51 and the combination of R43 and R51 operates as a potentiometer, producing a much greater lowering of screen voltage than is produced with the conditions obtaining on the introduction of R43 in series with the P.A. screen feed (para. 124). Thus the power output is reduced to about one-sixth of the normal value.

133. Again because relay 1RL7 is *not* operated, the earth on the LOW POWER line is extended via contact 7A to pin 15 of selector unit plug 13AF (fig. 2) and thence to the meter shunt relay MS in the selector unit. With this relay operated the meter shunts are changed; these shunts R3, R5 and R6 are associated with the aerial indicator circuits so as to increase the sensitivity of the meter circuits on low power operation and maintain an adequate reading.

134. Additional use of the LOW POWER facility is made for protective purposes. Under MANUAL and COARSE TUNE conditions, the LOW POWER line

RESTRICTED

is earthed via FTA2 and AMA2 so that the transmitter is automatically protected against damage which could be caused by severe mistuning.

135. In the aerial tuning unit the pressure operated switch SWC is connected to the LOW POWER line. For reasons of space limitations, it is impracticable to employ a variable capacitor which will withstand the peak RF voltage generated by the transmitter when working at full power unless the air or gas surrounding it is *dry*. The tuning unit is therefore pressurized with dry air. It is arranged that loss of pressurization (which indicates leakage and therefore the possibility of ingress of moist air) shall cause the pressure switch SWC to operate and switch the transmitter to LOW POWER.

136. A further pressure-operated switch SWB is arranged to give an indication that pressurization is failing before the critical condition is reached. So long as the canister pressure remains above 16 lb. sq. in. absolute, switch SWA is closed and illuminates the SAFE lamp in control unit Type 7216. Consequently before the pressure in the canister drops to a value low enough to operate SWC, the extinction of the SAFE lamp (by the opening of SWB) will indicate that leakage is occurring.

Note . . .

Atmospheric pressure at ground level is 14.7 lb. sq. in. absolute.

RESTRICTED

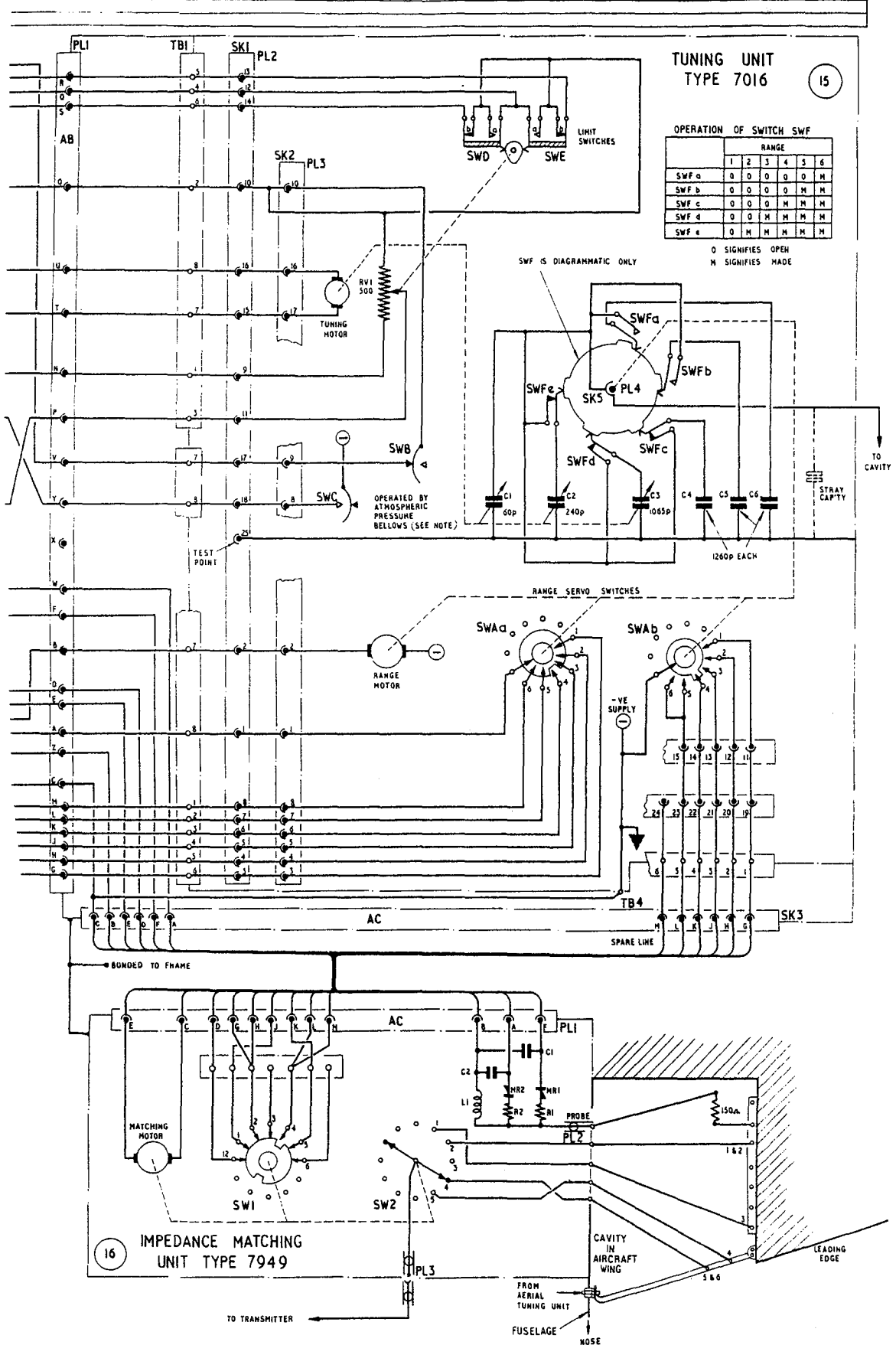
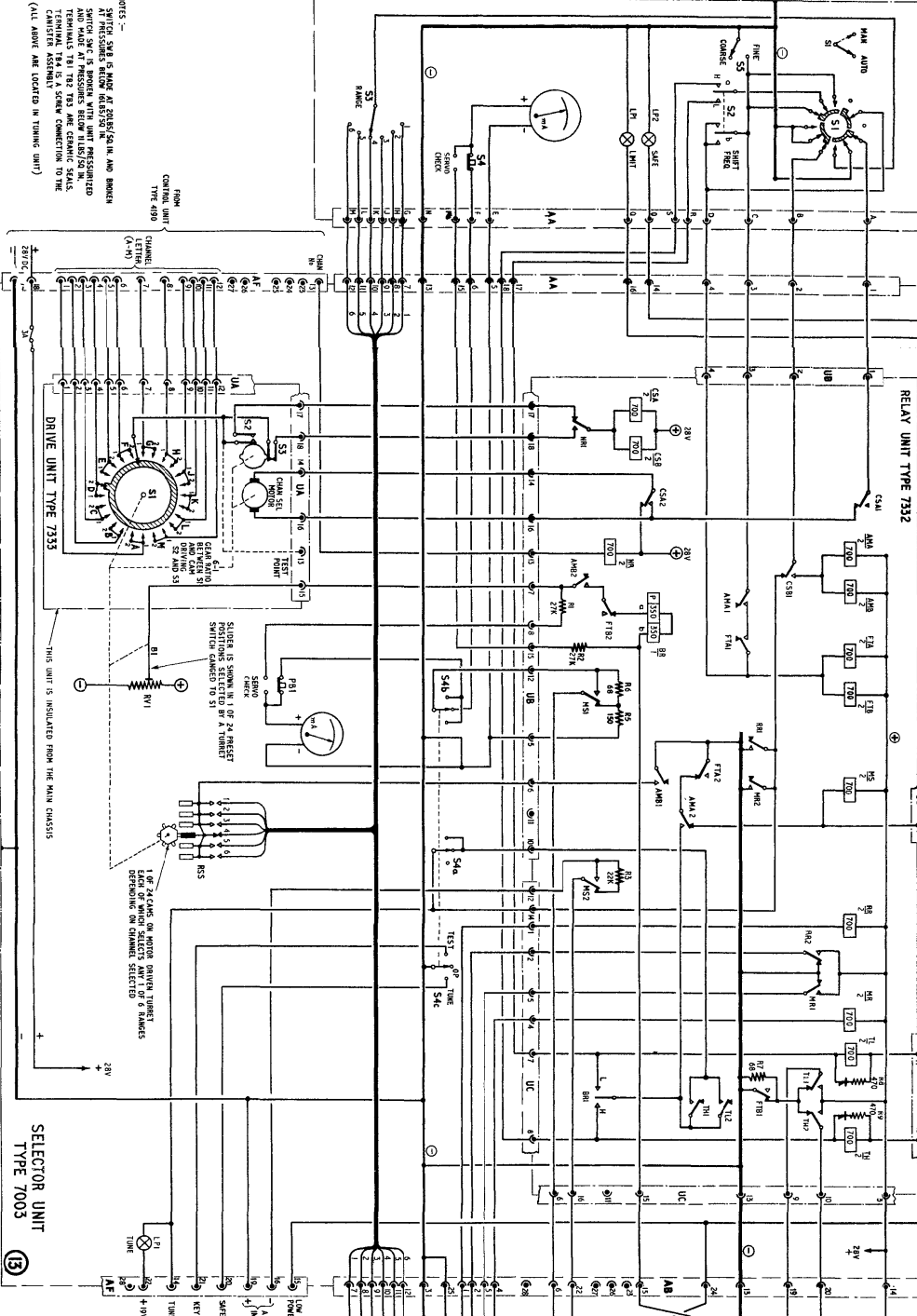

Fig. 8

MAIN CONTACTS

CSA1 CSA2 CSA3 CSA4 CSA5 CSA6 CSA7 CSA8 CSA9 CSA10 CSA11 CSA12 CSA13 CSA14 CSA15 CSA16 CSA17 CSA18 CSA19 CSA20 CSA21 CSA22 CSA23 CSA24 CSA25 CSA26 CSA27 CSA28 CSA29 CSA30 CSA31 CSA32 CSA33 CSA34 CSA35 CSA36 CSA37 CSA38 CSA39 CSA40 CSA41 CSA42 CSA43 CSA44 CSA45 CSA46 CSA47 CSA48 CSA49 CSA50 CSA51 CSA52 CSA53 CSA54 CSA55 CSA56 CSA57 CSA58 CSA59 CSA60 CSA61 CSA62 CSA63 CSA64 CSA65 CSA66 CSA67 CSA68 CSA69 CSA70 CSA71 CSA72 CSA73 CSA74 CSA75 CSA76 CSA77 CSA78 CSA79 CSA80 CSA81 CSA82 CSA83 CSA84 CSA85 CSA86 CSA87 CSA88 CSA89 CSA90 CSA91 CSA92 CSA93 CSA94 CSA95 CSA96 CSA97 CSA98 CSA99 CSA100

14 CONTROL UNIT TYPE 7216



- NOTES -
- 1 SWITCH SWA IS MADE AT 205R/52U AND NUMBER AT PRESSURE BELOW 115R/52U. IMMEDIATELY
 - 2 AND MADE AT PRESSURES BELOW 115R/52U IN
 - 3 TERMINALS TB1 TB2 TB3 ARE CERAMIC SEALS
 - 4 CERAMIC ASSEMBLY
- (ALL ABOVE ARE LOCATED IN TUNING UNIT)

AIR DIAGRAM
6103S/MIN.

103235-1000-1115-200-0000-0000

ARI 5874 - Aerial system Type 9502 - circuit for Vulcan
RESTRICTED

15 TUNING UNIT TYPE 7016

OPERATION OF SWITCH SWF

SWITCH	NAME	POSITION	FUNCTION
SWF 0	0	0	0
SWF 1	1	1	1
SWF 2	2	2	2
SWF 3	3	3	3
SWF 4	4	4	4
SWF 5	5	5	5
SWF 6	6	6	6
SWF 7	7	7	7
SWF 8	8	8	8
SWF 9	9	9	9
SWF 10	10	10	10
SWF 11	11	11	11
SWF 12	12	12	12
SWF 13	13	13	13
SWF 14	14	14	14
SWF 15	15	15	15
SWF 16	16	16	16
SWF 17	17	17	17
SWF 18	18	18	18
SWF 19	19	19	19
SWF 20	20	20	20
SWF 21	21	21	21
SWF 22	22	22	22
SWF 23	23	23	23
SWF 24	24	24	24
SWF 25	25	25	25
SWF 26	26	26	26
SWF 27	27	27	27
SWF 28	28	28	28
SWF 29	29	29	29
SWF 30	30	30	30
SWF 31	31	31	31
SWF 32	32	32	32
SWF 33	33	33	33
SWF 34	34	34	34
SWF 35	35	35	35
SWF 36	36	36	36
SWF 37	37	37	37
SWF 38	38	38	38
SWF 39	39	39	39
SWF 40	40	40	40
SWF 41	41	41	41
SWF 42	42	42	42
SWF 43	43	43	43
SWF 44	44	44	44
SWF 45	45	45	45
SWF 46	46	46	46
SWF 47	47	47	47
SWF 48	48	48	48
SWF 49	49	49	49
SWF 50	50	50	50
SWF 51	51	51	51
SWF 52	52	52	52
SWF 53	53	53	53
SWF 54	54	54	54
SWF 55	55	55	55
SWF 56	56	56	56
SWF 57	57	57	57
SWF 58	58	58	58
SWF 59	59	59	59
SWF 60	60	60	60
SWF 61	61	61	61
SWF 62	62	62	62
SWF 63	63	63	63
SWF 64	64	64	64
SWF 65	65	65	65
SWF 66	66	66	66
SWF 67	67	67	67
SWF 68	68	68	68
SWF 69	69	69	69
SWF 70	70	70	70
SWF 71	71	71	71
SWF 72	72	72	72
SWF 73	73	73	73
SWF 74	74	74 </tr	

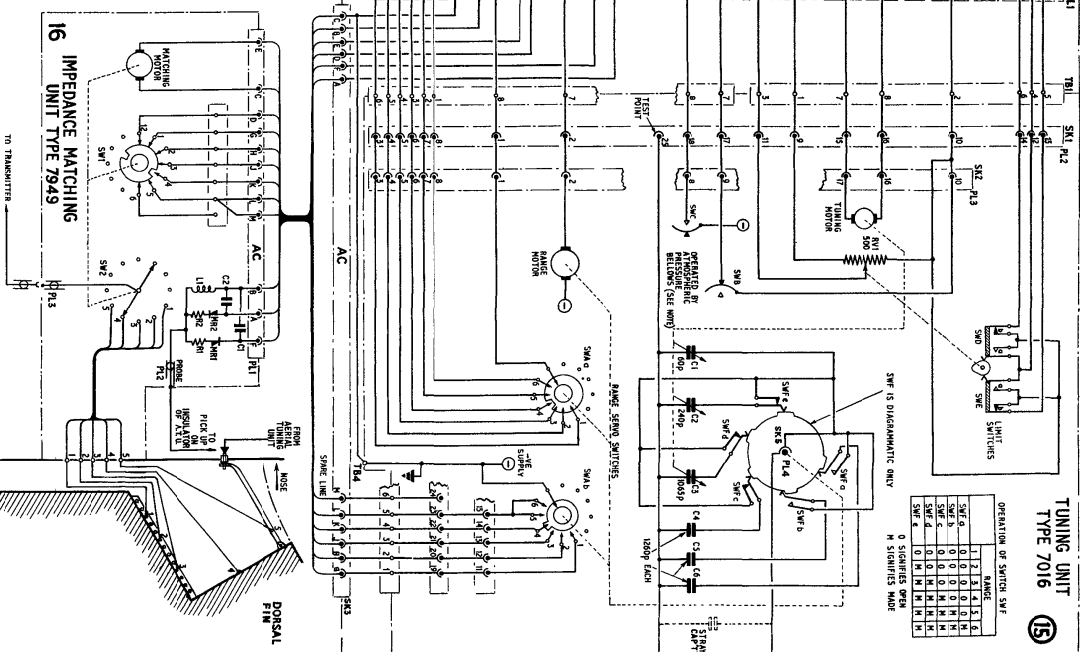

16 IMPEDANCE MATCHING UNIT TYPE 7949



Chapter 13

SETTING UP AND OPERATION OF A.R.I.5874 WITH AERIAL SYSTEM TYPE 9502

LIST OF CONTENTS

	Para.		Para.
Setting up instructions			
Introduction...	1	Control unit Type 4190	29
Preparation for setting-up the transmitter		Selector unit Type 7003	31
Control unit Type 4190	3	Receiver	32
Frequency band 2·8-7·0 Mc/s	10	General	37
Frequency band 7·0-18·1 Mc/s	11	Control unit Type 4189	40
Preparation for setting-up the receiver	12	Setting up procedure for aerial system Type 9205 when calibration card is not available	45
Setting up the complete installation		Control unit Type 7216	46
Transmitter	17	Selector unit Type 7003	54
Control unit Type 4190	18	Transmitter	56
Control unit Type 7216	19	Operating instructions...	58
Aircraft power supplies	20	Receiver	60
Control unit (remote) Type 4189	24	Transmitter	61
Control unit Type 4190	25	Control unit Type 7216 (suppressed aerial)	62
Control unit (remote) Type 4189	26	Control unit (remote) Type 4189	63
Selector unit Type 7003	27		

SETTING UP INSTRUCTIONS

Introduction

1. The following instructions apply primarily to those installations fitted with aerial system Type 9502. They can also be used as a basis for setting up other suppressed aerial installations of ARI.5874 using cavity or notch aerials.

2. When the transmitter-receiver equipment and the aerial system have been set up in accordance with these instructions, all power switching, channel selection and service switching is made at the control unit (remote) Type 4189. Exceptionally (and if necessary), fine tuning of the aerial system can be made at the control unit Type 7216 during operation.

Preparation for setting-up the transmitter

Control unit Type 4190

3. Remove the control unit Type 4190 from the rack and take off the dust cover after releasing the fastener at the rear.

4. Open the crystal retainers covering the crystal sockets on each side of the chassis.

5. Insert crystal units Type ZDH of the selected (carrier) frequencies in the numbered sockets, using the crystal extractor (located in receiver) if required.

6. Enter the crystal frequencies against the channel designation on the plate fitted to the front panel of the control unit Type 4190.

7. Close the crystal retainers and, after replacing the dust cover, re-insert the control unit in the racking.

8. Remove the cover from the potentiometers at the top of the front panel.

9. Select the positions of the 24 switches S2/1 and S2/2 on the control unit Type 4190 according to the channel frequencies to be used. (Channels 1A-1M on left and 2A-2M on right).

Frequency band 2·8-7·0 Mc/s

10. For the transmitter band 2·8 to 7·0 Mc/s the switch knobs should be "out" with the channel letter marking vertically inclined.

Frequency band 7·0-18·1 Mc/s

11. For band 7·0 to 18·1 Mc/s the switch knobs should be pushed in against the spring loading and turned 90 deg. until they locate firmly in that position. With the switch knobs "in" the channel letter markings will be horizontally inclined.

Note . . .

The tuning tool, clipped in the cover over the potentiometers, may be used for turning the switch knobs as required.

Preparation for setting-up the receiver

12. Slide the receiver from the rack and remove the dust cover.

13. Open the door of the crystal oven. Place the crystal units Type ZDH for the required channels in the numbered sockets (using crystal extractor located in tuning potentiometer cover on receiver front panel if required) and enter the channel frequencies on the tablet provided on the front panel. The crystal frequencies (f_x) have the following relationship to the channel frequency (f).

RESTRICTED

$f = f_x \pm 2.15 \text{ Mc/s}$: where f and f_x are in Mc/s, and with the proviso that f_x lies in the range 4.95 to 15.95 Mc/s.

14. The crystal frequencies must be chosen in the following manner:—

	f	f_x
Band 1	2.8 to 5.2	$f + 2.15 \text{ Mc/s}$
Band 2	5.2 to 9.7	$f + 2.15 \text{ Mc/s}$
Band 3	9.7 to 18.1	$f - 2.15 \text{ Mc/s}$

15. When all the crystals required for use are in position, close the door of the crystal oven, replace the dust cover and return the receiver to the rack. Remove the tuning potentiometer cover.

16. Select the required frequency ranges using the two groups of switches S9 and S10 as follows:—

Band 1	2.8 to 5.2 Mc/s	Switch lever UP
Band 2	5.2 to 9.7 Mc/s	Switch lever CENTRE
Band 3	9.7 to 18.1 Mc/s	Switch lever DOWN

Note . . .

The band numbers correspond to the three scales shown on the tuning drum dial.

Setting up the complete installation

Transmitter

17. Turn the AUTO/MAN switch 2S3 to AUTO. The meter switch 2S2 may be turned to any position.

Note . . .

If the proximity of the transmitter with relation to the control and drive unit is such that the meters on both units can be observed together, it is advantageous when tuning to leave the transmitter meter switch 2S2 in the "Ic" position. With these conditions the cathode-current of the P.A. stage can be continuously noted and some of the switching of the control and drive unit obviated.

Control unit Type 4190

18. Place the meter switch on the drive unit 1S1 to indicate P.A. drive, i.e., position Ig.

Control unit Type 7216

19. (Aerial system control unit). Turn the AUTO/MAN switch to AUTO.

Aircraft power supplies

20. Switch on 28-volt supply to ARI.5874 by means of the switch in the operating position marked "ARI.5874 supply." This supplies 28 volts to the equipment and 28 volts to the voltage regulator which gives a regulated supply of 19 volts to the equipment.

Note . . .

The voltage regulator (5UC/6010) will not necessarily be an integral part of the ARI.5874. The installation may be wired into whatever 19V power supplies are available in the particular aircraft.

21. Check that battery supply is between 27 and 29V.

22. Check that regulated supply is 19 volts

(indicated on voltage regulator). If not, press the SET switch and adjust the voltage control until the meter reads 19 volts or until the needle is within the area coloured red. Press the CHECK switch and note that the meter reading does not vary outside the limits marked in red.

23. Check that the transmitter HIGH/LOW POWER switch is in the HIGH power position. This switch is located near the control unit (remote) Type 4189.

Control unit (remote) Type 4189

24. Make the following adjustments on the remote control unit Type 4189.

- (1) Move the power switch 11S3 to position S/BY.
- (2) Move the CHANNEL NO. switch 11S2 to position 1 or 2 as required.
- (3) Move the CHANNEL letter switch 11S1 to the first channel to be tuned.
- (4) Move the services switch 11S4 to CW1.
- (5) Set the FINE TUNING control to zero.
- (6) Set the RF GAIN control to maximum (clockwise).
- (7) Wait until the channel has "selected", i.e. until the TUNE lamp becomes extinguished.

Control unit Type 4190

25. Locate the associated potentiometer tuning button of the channel selected and turn it fully counter-clockwise.

Control unit (remote) Type 4189

26. Move the power switch S3 to TX (after a 30-second delay in position S/BY).

Selector unit Type 7003

27. Set the aerial selector unit SET RANGE switch to the range indicated on the aerial calibration card for the aircraft type.

28. Press the SERVO CHECK button on the aerial selector unit, insert the tuning tool or screwdriver in the SET TUNING preset and adjust the preset until the reading in the meter gives the same approx. number of degrees as indicated on the calibration chart.

Control unit Type 4190

29. Switch the meter to Ig, hold the keyswitch 1S4 in the TUNE position and rotate the potentiometer tuning button until a reading is obtained in the meter. Tune for maximum meter reading.

30. Move the key switch to position TEST and check that there is a current reading with the meter switch in position Ic.

Selector unit Type 7003

31. Move the TUNE/TEST key on the aerial selector unit to the TUNE position and readjust the SET TUNING preset on the aerial selector unit for a maximum HF reading in the meter.

RESTRICTED

Receiver

32. Set the TUNE/NORMAL switch on the receiver front panel to TUNE.

33. Using the tuning tool, turn the required potentiometer control knob to the fully counter-clockwise position.

34. Rotate the receiver tuning control TUNE until the required frequency is indicated on the scale against the cursor. Then, using the phones, finally adjust the TUNE control until the receiver noise reaches the maximum.

35. Leave the TUNE control in this position and turn the appropriate potentiometer control knob clockwise until the TUNING lamp goes out. This completes the tuning of the particular channel.

36. Operate the TUNE/NORMAL switch to NORMAL and check that there is no movement of the TUNE control.

Note . . .

If it is required to set up further channels, the TUNE/NORMAL switch may be left in the TUNE position (this is in the interest of clearing the interlock circuits). It is emphasized that after the equipment has been set up, the switch must be left in the NORMAL position.

General

37. Repeat for other frequencies and channels as required.

38. Note that during all the tuning operations of the aerial a glow is observed in the various TUNE lamps.

39. When all required channels have been tuned switch the TUNE/NORMAL switch on the receiver to NORMAL. Replace the tuning potentiometer covers.

Control unit Type 4189

40. Operate the morse key and check that there is a reading in the meter.

41. Operate the services switch 11S4 to R/T, MCW, and CW1; check that there is sidetone and that the transmitter is modulating.

42. Switch to INTERTUNE and swing the FINE TUNE control, checking that a variation in audio beat note is obtained.

43. Select all the channels in turn, checking that the TUNE lamp operates during the automatic channel selection.

44. On each channel check the receiver on INTERTUNE and the transmitter output on CW1, by means of the control unit meter (*para. 40 and 42*).

Note . . .

Checking the receiver on INTERTUNE is only applicable when the receiver is on the same frequency as the transmitter ± 7 kc/s.

Setting up procedure for aerial system Type 9205 when calibration card is not available

45. Before setting up the aerial system ensure that the tuning procedure outlined in para. 1 to 26 has been carried out with the exception of para. 19; here the AUTO/MANUAL switch on the aerial control unit (remote) Type 7216 must be turned to MANUAL.

Control unit Type 7216

46. Move the RANGE switch to position 6. Switch position 6 is related to the lower end of the frequency range (2.8 Mc/s) and position 1 the higher end (18.1 Mc/s).

47. Set the FINE/COARSE switch to COARSE. (In the COARSE position of the switch, the transmitter is automatically switched to the lower power condition).

48. Hold the morse key down and search with the FREQ. SHIFT control on the aerial control unit for maximum reading on the meter situated above the FREQ. SHIFT control.

49. If it is not possible to obtain a peak meter reading, repeat the procedure on switch position 5 and so on until a maximum reading is obtained. It may be that a near peak reading can be obtained at one end of a range, in this case it is probable that a better reading will be obtained in the next position of the switch.

50. When a reading due to the fundamental is obtained switch the FINE/COARSE switch to FINE and make a final adjustment for a maximum reading. (In the FINE position of the switch, the transmitter is automatically switched to full power).

51. When it is required to test for the correct movement of the main tuning capacitor in the aerial tuning unit Type 7016 the SERVO CHECK switch is used. With the switch pressed and the FREQ. SHIFT key moved from side to side, the rotation of the moving vanes of the capacitor is indicated by the meter needle as it moves over the scale calibrated in degrees.

52. When the aerial tuning unit is finally tuned to the transmitter frequency, switch the remote control unit Type 4189 to S/BY, press the SERVO CHECK switch on the aerial remote control unit and make a note of the position of the moving vanes of the capacitor as indicated on the scale calibrated in degrees. Also note the range setting.

53. On completion of the setting up as described above, move the AUTO/MAN switch on the aerial remote control unit to AUTO and observe that the aerial selector unit automatically takes up the same channel as set on the remote control unit Type 4189. Finally ensure that the FINE/COARSE switch is left in the FINE position. (Checks of meter readings and retuning of the transmitter should be done in the FINE position, i.e. at full power.)

RESTRICTED

Selector unit Type 7003

54. Move the aerial selector unit SET RANGE switch to the same range as finally selected on the aerial remote control unit.

55. Press the SERVO CHECK button on the aerial selector unit, insert the tuning tool or screwdriver in the SET TUNING preset and adjust the preset until the reading in the meter gives the same number of degrees as noted on the aerial remote control unit (para. 52).

Transmitter

56. Switch on the transmitter by moving the power switch on the remote control unit Type 4189 to position TX. Retune the transmitter for maximum grid drive. Move the TUNE/TEST key on the aerial selector unit to the TUNE position and readjust the SET TUNING preset on the aerial selector unit for a maximum HF reading in the meter.

Important Note . . .

After setting up the aerial system the transmitter must be retuned for maximum grid drive. The aerial tuning should then be "retouched" for maximum output. This procedure must be carried out because the impedance presented to the transmitter by the aerial system in its "off tune" condition should have changed after tuning (down to approx. 75 ohms) and consequently the transmitter will be off tune.

57. At this stage carry out the tuning procedure as outlined in para. 31 to 44.

OPERATING INSTRUCTIONS

58. No attempt should be made to operate the equipment until it has been properly set up as described in para. 3 to 57.

59. Make the following checks on the equipment before switching on at the remote control unit.

Receiver

60. Check that the TUNE/NORMAL switch is in the NORMAL position. (If the potentiometer and switch cover is properly fastened in position a projection from the cover ensures that the switch is in the NORMAL position).

Transmitter

61. Check that the AUTO/MAN switch is in the AUTO position.

Control unit Type 7216 (suppressed aerial)

62. Check that the AUTO/MAN switch is in the AUTO position.

Control unit (remote) Type 4189

63. After ensuring that the local switches on the equipment are in the positions described above, the equipment may be operated from the remote control unit.

- (1) Turn the power switch to S/BY.
- (2) Select the channel to be used on the CHANNEL NUMBER and CHANNEL LETTER switches.
- (3) The TUNE lamp will go out when the equipment is tuned.
- (4) Select the position required on the service switch (R/T, MCW, CW1, CW2 or INTERTUNE).

Note . . .

CW2 is position of greatest selectivity. To obtain the "Intertune" facility the power switch should be on TX.

- (5) Adjust the final tuning by means of the FINE TUNING control.
- (6) Wait 30 seconds and then switch to TX. The transmitter is ready for use when the key is pressed.
- (7) Operate the LOW/HIGH switch according to the output power required.

Note . . .

If the transmitter is required for "instant readiness", the power switch should be left on TX. The 30-second delay is only applicable on first switching to S/BY.

- (8) The dial and the meter illumination is controlled by the DIM control. The TUNE lamp is dimmed by rotating the lamp bezel.
- (9) The gain of the receiver is varied by the rotation of the RF GAIN control.
- (10) When receiving on CW, the beat note can be varied by adjustment of the FINE TUNING control.

Note . . .

It may be necessary when airborne to slightly retune the aerial circuit by peaking up to maximum output in the meter on the aerial control unit by means of the FREQ. SHIFT control with the FINE/COARSE switch in the FINE position.

RESTRICTED

Chapter 14

SUPPRESSED AERIAL INSTALLATIONS USING AERIAL SYSTEM TYPE 9502

LIST OF CONTENTS

	Para.		Para.
<i>Introduction</i>	1	<i>Cavity systems</i>	9
<i>Standard racking and back-plates</i>	4	<i>Installation and cabling</i>	15
<i>Connector, unit and back-plate coding</i>	5	<i>Fixed equipment</i>	16
<i>Units outside the racking system</i>		<i>Removable equipment</i>	19
<i>Control unit Type 7216</i>	6	<i>Connectors</i>	20
<i>Tuning unit (aerial) Type 7016</i>	7	<i>Equipment wires specification</i>	22
<i>Impedance matching unit Type 7949</i>	8		

LIST OF TABLES

	Table
<i>Connector and unit coding</i>	1
<i>Fixed equipment</i>	2
<i>Removable equipment</i>	3
<i>Connector schedule—Valiant</i>	4
<i>Connector schedule—Vulcan</i>	5

LIST OF ILLUSTRATIONS

	Fig.
<i>Aerial tuning unit in Vulcan</i>	1
<i>Suppressed aerial cavity in Vulcan</i>	2
<i>Layout of cavity and tuning and matching equipment in Vulcan</i>	3
<i>ARI.5874 with suppressed aerial system Type 9502—Valiant and Vulcan</i>	4

Introduction

1. Aerial system Type 9502 is now being fitted to the Valiant, Vulcan and Victor aircraft. The arrangement of the cavity or notch aerial differs for each type of aircraft and will be separately described.

2. In Chapter 10 of this Section an earlier type of suppressed aerial is described (coil-energization as fitted to the Valiant) but this will be superseded by aerial system Type 9502 (*Chap. 12*).

Note . . .

At the time of writing the notch aerial for the Victor is under development, details will be issued later.

3. The aircraft installations described in this chapter come under the general heading ARI.5874; any variant of the suppressed aerial installation is included under this general heading.

Standard racking and back-plates

4. The construction of the racking system is normally carried out by the aircraft constructor, the racking conforms with that described in the British Standards Institution publication "Sizes and Forms of Civil Aircraft Radio Equipment". The physical arrangement of the racking for ARI.5874 is described in Chap. 10 of this Section.

Connector, unit and back-plate coding

5. The plugs and sockets on the rear panel of each unit are numbered in accordance with the circuit references, but the numbering of the plugs and sockets on the back-plates is related to the particular connector which it terminates, *e.g.* the socket AA on the rear panel of the selector unit will connect with the 20-way plug 13AA on the back-plate. The plug is one termination of the 20-core connector AA, the other end being connected to the control unit Type 7216 at socket 14AA. The coding of the individual units, back-plates and the associated connectors is given in Table 1.

RESTRICTED

TABLE I
Connector and unit coding

Unit	Unit code
Control unit Type 4190	1
Transmitter Type T.4188	2
Power and radio unit Type 4192	3
Receiver Type R.4187	4
Control unit (remote) Type 4189	11
Junction box Type 4191	12
Selector unit Type 7003	13
Control unit Type 7216	14
Tuning unit (aerial) Type 7016	15
Impedance matching unit Type 7949	16
Voltage regulator	—

Connector code		Terminations	
A	1A	Control unit Type 4190	3A Power and radio unit
B	1B	Control unit Type 4190	2B Transmitter
C	1C	Control unit Type 4190	2C Transmitter
D	2D	Transmitter	3D Power and radio unit
E	2E	Transmitter	3E Power and radio unit
F	3F	Power and radio unit	— Intercom. equipment
G	—	—	—
H	—	—	—
J	3J	Power and radio unit	— External transmitter interlock or transmitter Type T.4188 shorting plug
K	—	—	—
L	1L	Control unit Type 4190	4L Receiver
M	4M	Receiver	— Power supplies
N	3N	Power and radio unit	4N Receiver
P	3P	Power and radio unit	— Power supplies
AA	13AA	Selector unit Type 7003	14AA Control unit Type 7216
AB	13AB	Selector unit Type 7003	15AB Tuning unit (aerial) Type 7016
AC	15AC	Tuning unit (aerial) Type 7016	16AC Impedance matching unit Type 7949
AD	4AD	Receiver	12AD Junction box
AE	1AE	Control unit Type 4190	12AE Junction box
AF	1AF	Control unit Type 4190	13AF Selector unit Type 7003
AG	1AG	Control unit Type 4190	16AG Impedance matching unit Type 7949
AH	11AH	Control unit (remote) Type 4189	12AH Junction box
AL	16AL	Impedance matching unit Type 7949	— To probe wire (in cavity or close proximity)

Units outside the racking system

Control unit Type 7216

6. The control unit Type 7216 is not mounted on the racking system but is constructed so that it may be panel or console mounted. This unit is not fitted with anti-vibration mountings.

Tuning unit (aerial) Type 7016

7. Since the aerial tuning unit is mounted in close proximity to the cavity, it is provided with its own

mounting tray. This tray is rectangular and is fitted with anti-vibration mountings. The tuning unit canister is secured to the mounting tray "quick-release" mounting, the mounting tray being bolted to the airframe in a conventional manner. The mounting tray is illustrated in *fig. 1* and also in Chap. 6.

Impedance matching unit Type 7949

8. In the Valiant aircraft the impedance matching

RESTRICTED

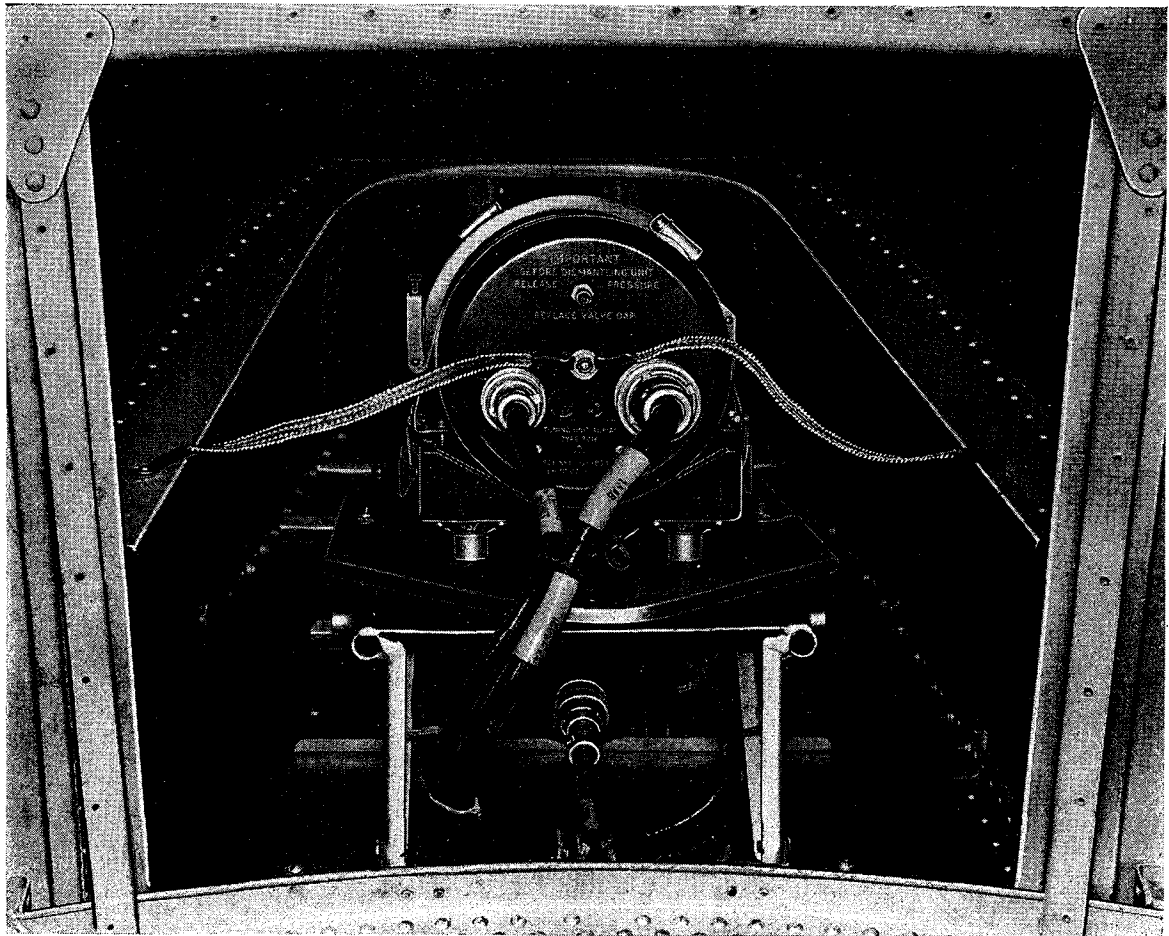

Fig. 1. Aerial tuning unit in Vulcan

unit is mounted "in" the skin of the aircraft so that one side of the unit is external to the fuselage (in the wing) and the other side of the unit projects through the skin to the inside of the fuselage. No anti-vibration mountings are used and the unit is secured to the airframe by a bracket which may be considered as an integral part of the unit.

Cavity systems

9. The suppressed aerial cavities vary in shape, size and location in different types of aircraft, the location depending mainly on the structural layout of the fuselage and wings.

10. In the Valiant aircraft the cavity is in the port wing with a location similar to that which originally housed the inductor Type 7006 (now superseded—Chap. 5, fig. 1). A schematic drawing of the connections to the cavity is given in fig. 4 (at end of Chapter).

11. An illustration of the cavity in the Vulcan aircraft is shown in fig. 2. This shows the metal braid connections from the impedance matching unit to the walls of the cavity. The tubular connector at the top of the cavity is the aerial connection to the tuning unit. The large plastic-covered

ducting through the centre of the cavity is not a part of the aerial system.

12. The full extent of the cavity is not shown in this illustration (fig. 2) but it is narrowed down and continued below the impedance matching unit as shown in fig. 3. This illustration shows the approximate location within the dorsal fin of the aerial tuning unit and impedance matching unit with relation to the cavity.

13. A circlip attached to the "aerial insulator" of the aerial tuning unit gives sufficient pick-up to the probe connection from PL2 of the impedance matching unit (the pick-up from the probe is applied to a detector circuit in the matching unit). The aerial tuning unit is carefully earthed by means of copper braiding connected between four earth terminals at the aerial end of the unit and nearest points on the aircraft fuselage. Earthing strips are also connected between the other end of the aerial tuning unit and fuselage as shown in fig. 1.

14. In this illustration (fig. 1) the connection to PL1 of the impedance matching unit can be seen below the mounting bracket of the aerial tuning unit. The impedance matching unit is mounted

RESTRICTED



Fig. 2. Suppressed aerial cavity in Vulcan

RESTRICTED

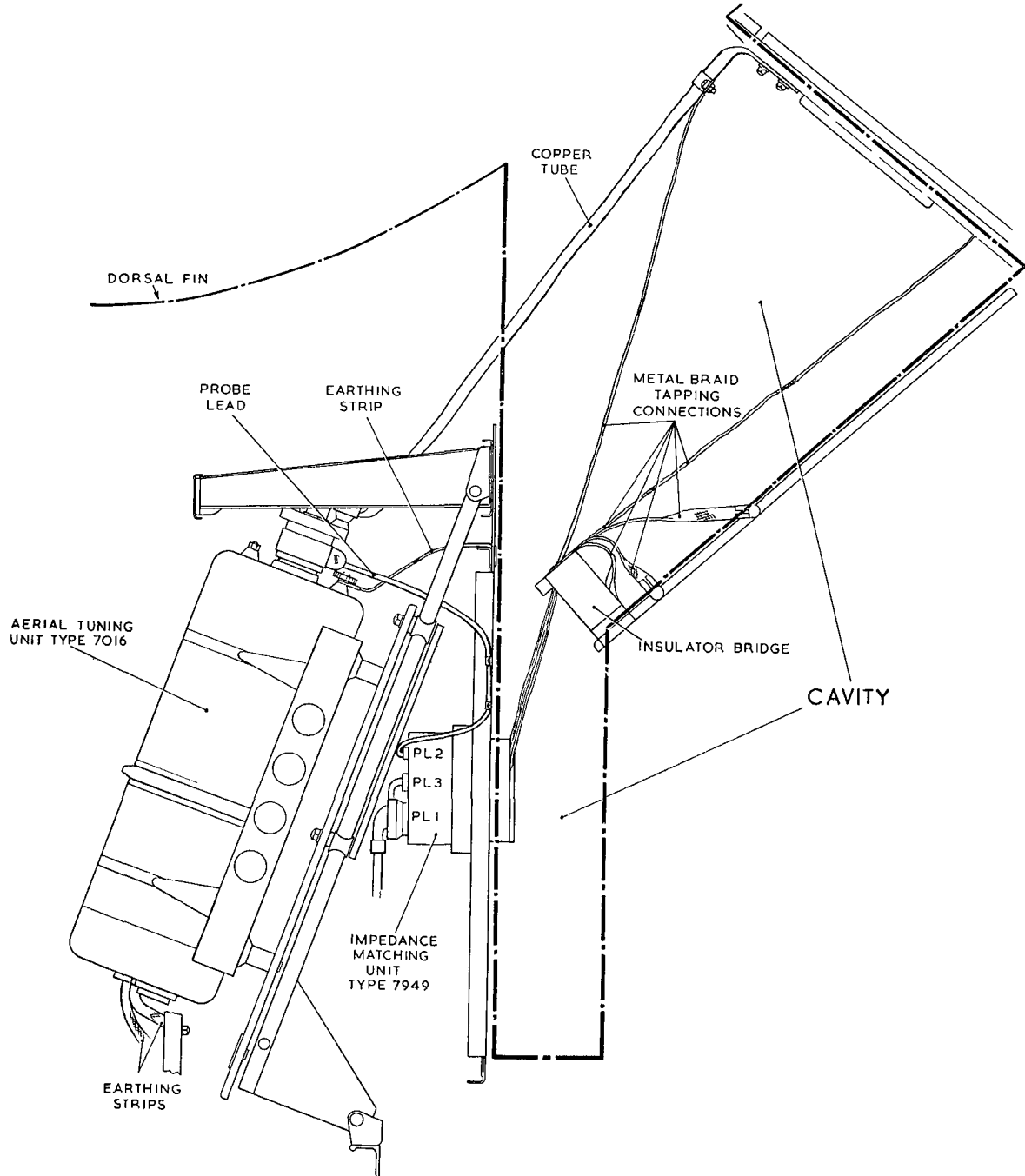

Fig. 3. Layout of cavity and tuning and matching equipment in Vulcan

in the "bulkhead" between the inside of the dorsal fin and the cavity such that the tapping switch connections are inside the cavity. The connections to the aerial tuning unit and the transmitter output are at the rear of the impedance matching unit inside the dorsal fin.

Installation and cabling

15. There are variant installations in the one designation ARI.5874, the complement of movable equipment and cabling being different in each case.

In the following description information is given on the main items of equipment and ancillaries which make up the installation for the Valiant, Vulcan (and later the Victor) aircraft.

Fixed equipment

16. The items in Table 2 are listed as the fixed equipment required for the aircraft installation, the items are normally supplied to the aircraft contractor for installation at the works.

RESTRICTED

TABLE 2
Fixed equipment

A.M. Stores Ref.	Description	Service	Dimensions (approx.)	
			Width	Height
10AD/474	Back-plate	For selector unit Type 7003	5 $\frac{7}{8}$ in.	5 in.
10AR/438	Back-plate	For power and radio unit Type 4192	10 in.	5 in.
10AR/440	Back-plate	For transmitter T.4188	7 $\frac{1}{4}$ in.	3 in.
10AR/441	Back-plate	For control unit Type 4190	7 $\frac{1}{4}$ in.	7 in.
10AR/442	Back-plate	For receiver R.4187	7 $\frac{3}{4}$ in.	3 in.
5UC/6011	Back-plate	For voltage regulator (5UC/6010)	3 $\frac{3}{4}$ in.	5 in.
—	Terminal blocks	As shown in fig. 4	—	—
—	Switch label	Marked "ARI.5874 ON/OFF"	—	—
—	Switch label	Marked "TRANSMITTER OUTPUT HIGH/LOW"	—	—
10AJ/249	Mounting Type 9056	For tuning unit (aerial) Type 7016, includes mountings—A.V. type, 12 lb.	7 $\frac{1}{2}$ in.	(Length) 14 $\frac{1}{2}$ in.

17. An illustration of a typical installation for the Valiant and Vulcan aircraft is shown in fig. 4.

the exception of those units which have direct entry plugs and sockets.

18. The interconnections of the installation are shown as they are connected to the back-plates with

Removable equipment

19. The items in Table 3 are listed as removable and include the main units of the installation.

TABLE 3
Removable equipment

A.M. Stores Ref	Description	Service	Approx weight
5UC/6010	Voltage regulator	Stabilized 19V supply to equipment	10.75 lb.
10L/16204	Control unit (remote) Type 4189	Remote control of transmitter/receiver and aerial equipment	2.65 lb.
10D/19066	Junction box Type 4191	Junction box between remote control unit and transmitter/receiver	1.4 lb.
10L/16205	Control unit Type 4190	Control unit and drive unit for transmitter	13.6 lb.
10D/19065	Transmitter Type T.4188	For use with suppressed or open wire aerial system	15.8 lb.
10D/19064	Receiver Type R.4187	For use with suppressed or open wire aerial system	26 lb.
10D/19067	Power and radio unit Type 4192	HT power supplies for transmitting circuits	34 lb.
10L/293	Control unit Type 7216	For manual control of aerial equipment during setting-up and operation	1.75 lb.
10D/19248	Selector unit Type 7003	For pre-selection of aerial frequencies and automatic operation of servo systems	17 lb.
10B/16858	Impedance matching unit Type 7949	For matching aerial impedance to output of transmitter	2.5 lb.
10D/19833	Tuning unit (aerial) Type 7016	Aerial tuning unit	16.5 lb.

Connectors

20. The connectors described in Table 4 are for a complete installation in the Valiant aircraft. Table 5 lists typical connectors for the Vulcan.

21. Against the sleeve marking at each end of the connector is a reference in parenthesis; this is the code marking appearing on the back-plate against the socket or plug termination of the particular connector (*Table 1*).

Equipment wires specification

22. The equipment wires referred to in the

following tables are listed in Defence Specification DEF-12 "Equipment Wires"—which includes the following note:—

"The American—British—Canadian Supply Classification (A.B.C.S.C.) 'Class' number for the wires specified in this DEF Specification is 6145. This number and the item identification number shown in the tables make up the Catalogue number which should be quoted when reference is made to a particular wire, e.g. 6145-100168. Equipment wires shall be described by the Catalogue number followed by the name, type number, the conductor details and colour, e.g. 6145-100192, electrical equipment, Type 2S.7/0-0076 in. Red."

RESTRICTED

TABLE 4
Connector schedule—Valiant

Note.—The connectors in this schedule are typical for ARI.5874 in the Valiant aircraft.

Item in Fig. 4	Identity sleeve marking Type and Ref. No.	Overall length of cable	Destination sleeve marking		Remarks
			End A	End B	
1	EX/20C/6 (10HA/14145)	5 ft. 6 in.	*Control unit Type 4190 (1A)	Power and radio unit (3A)	<i>Pin to Pin</i> Wire 6145-100179 to Pin No. 1, 4, 5, 6, 7, 8, 9, 10, 11, 12, 13, 15, 16, 17, 18, 19, 20. Wire 6145-100229 to Pin No. 2, 3, 14.
2	EX/20C/7 (10HA/14146)	4 ft. 0 in.	*Power and radio unit (3D)	Trans T4188 (2D)	<i>Pin to Pin</i> Wire 6145-100168 to Pin No. 3, 4, 5, 8, 10, 13, 14, 19, 20, 28. Wire 6145-100179 to Pin No. 6, 7, 9, 11, 12, 16, 17, 25, 27, 15. Wire 6145-100229 to Pin No. 1, 2, 24. Wire 6145-100249 to Pin No. 22.
3	E23/40F/2 (10HA/14147)	†6 ft. 0 in.	Power and radio unit (3F)	Intercom.	INTERCOM. CONNECTIONS: <i>Pin Colour Sleeve</i> 1 Red Tel Pos 2 Blue Tel Neg & E 3 Green Mic 4 Yellow Mic 5 White Key 6 Black Power SW 7, 8 Earth (Screen) Sextometvinsmall
4	EX/40F/1 (10HA/15652)	—	TX Shorting plug (3J)	—	Pins 1 and 2 normally shorted with 22 S.W.G. tinned copper wire sleeved with P.V.C.
5	EX/50F/6 (10HA/14149)	†12 ft. 0 in.	*Recvr. R4187 (4M)	Power supply	{ POWER SUPPLY CONNECTIONS: (3 off Unipren 12) <i>Pin 4 1 3</i> <i>Sleeve 24V E 19V</i>
6	EX/20C/8 (10HA/14150)	3 ft. 9 in.	*Recvr. R4187 (4N)	Power and radio unit (3N)	<i>Pin to Pin</i> Wire 6145-100249 to Pin No. 1. Wire 6145-100179 to Pin No. 2, 3, 4.
7	EX/50F/7 (10HA/14151)	†12 ft. 0 in.	*Power and radio unit (3P)	Power supply	Dupren 35; Unipren 12. Pin Nos. 1 to 10 cores to be marked "EARTH" (Cable Dupren 35 Blue). Pin Nos. 13 to 20 cores to be marked "28V pos." (Cable Dupren Red). Pin Nos. 11 and 12 cores to be marked "19V pos." (Cable Unipren 12).
8	EB14/30C/R1 (10HA/17072)	8 ft. 6 in.	Recvr. 4187 (4AD)	J. Box 4191 (12AD)	Pin to Letter Consecutive 25 Metvinsmall 2.5.

RESTRICTED

Table 4—(contd.)

Item in Fig. 4	Identity sleeve marking Type and Ref. No.	Overall length of cable	Destination sleeve marking		Remarks
			End A	End B	
9	EB14/3OC/R2 (10HA/17073)	6 ft. 3 in.	Control unit 4190 (1AE)	J. Box 4191 (12AE)	Pin to Letter Consecutive 25 Metvinsmall 2-5.
10	E14/2OC/R1 (10HA/17074)	3 ft. 9 in.	**Control unit 4190 (1AF)	Selector unit (13AF)	Pin to Pin 1-25 25 Metvinsmall 2-5.
11	E31/30B/R2 (10HA/17075)	7 ft. 0 in.	**Selector unit (13AA)	Aerial control unit 7216 (14AA)	Pin to letter consecutive 18 Metvinsmall 2-5.
12	E14/3OC/R3 (10HA/17076)	9 ft. 0 in.	**Selector unit (13AB)	Break AB	Pin to Letter Consecutive 25 Metvinsmall 2-5.
13	B14/2OC/12 (10HA/14169)	14 ft. 3 in.	Aerial tuning unit (15AB)	Break AB	
14	D270/31C/1 (10HA/14157)	7 ft. 0 in.	Control unit 4190 (1B)	Trans. T4188 (2B)	Uniradio 70.
15	D221/32C/3 (10HA/14158)	6 ft. 6 in.	Control unit 4190 (1C)	Trans. T4188 (2C)	Uniradio 21.
16	D221/32C/4 (10HA/14159)	3 ft. 0 in.	Power radio unit (3E)	Trans. T4188 (2E)	Uniradio 21.
17	D270/31C/2 (10HA/14160)	6 ft. 0 in.	Control unit 4190 (1L)	Recvr. R4187 (4L)	Uniradio 70.
18	D221/31C/3 (10HA/14161)	10 ft. 0 in.	**Control unit 4190 (1AG)	Break AG	Uniradio 21.
19	D221/30C/2 (10HA/14168)	14 ft. 0 in.	Break AG	Imp. match. (16AG)	Uniradio 21.
20	B12/2OC/10 (10HA/14170)	2 ft. 6 in.	**Aerial tuning unit (15AC)	Imp. match. unit (16AC)	12 Metvinsmall 2-5.
21	B14/2OC/13 (10HA/14162)	2 ft. 3 in.	J. Box 4191 (12AH)	Control unit 4189 (11AH)	25 Metvinsmall Pin to Pin 1-25.
22	EX/50F/8 (10HA/14163)	Dupren 35 11 ft. 6 in. Unipren 12 0 ft. 6 in.	*Voltage regulator	Supply	Pins 1 to 7 cores to be marked "24V POS. IN" Cable Dupren 35 Red. Pin 12 core to be marked "EARTH" Cable Unipren 12. Pins 13 to 15 and 17 to 20 to be marked "19V POS. OUT" Cable Dupren 35 Blue.
23	D243/50E/12 (10HA/14171)	4 ft. 0 in.	**Imp. match. unit (16AL)	Probe	Uniradio 43.

Note . . .

- (a) Cables marked * are made up cables in polythene sleeving as there are no miniature cables in use which would meet the requirements.
- (b) Cable marked ** are for suppressed aerial installations only.
- (c) Cable lengths marked † include cut-back of 3 in. at the End B.

RESTRICTED

TABLE 5
Connector schedule—Vulcan

Note.—The connectors in this schedule are typical for ARI.5874 in the Vulcan aircraft.

Item in Fig. 4	Identity sleeve marking Type and Ref. No.	Overall length of cable	Destination sleeve marking		Remarks
			End A	End B	
1	E493/20C/R3 (10HA/15339)	4 ft. 0 in.	*Control unit 4190 (1A)	Type Power and radio unit (3A)	<i>Pin to Pin</i> Wire 6145-100179 to Pin No. 1, 4, 5, 6, 7, 8, 9, 10, 11, 12, 13, 15, 16, 17, 18, 19, 20. Wire 6145-100229 to Pin No. 2, 3, 14.
2	E494/20C/R3 (10HA/16876)	1 ft. 9 in.	*Power and radio unit (3D)	Trans T4188 (2D)	
3	EB23/20D/R1 (10HA/16877)	7 ft. 6 in.	Power and radio unit (3F)	Intercom.	INTERCOM. CONNECTIONS: <i>Pin Colour Sleeve</i> 1 Red Tel Pos 2 Blue Tel Neg. & E 3 Green Mic 4 Yellow Mic 5 White Key 6 Black Power SW 7, 8 Earth & screen Sextometvinsmall.
4	EX/40F/1 (10HA/15652)	—	TX Shorting plug (3J)	—	Pins 1 and 2 normally shorted with 22 S.W.G. tinned copper wire sleeved with P.V.C.
5	E498/50F/R4 (10HA/16878)	†3 ft. 6 in.	*Recv. R4187 (4M)	Power supply	3 off Unipren 12. <i>Pin:</i> 4 1 3 <i>Sleeve:</i> 24V E 19V
6	E495/20C/R4 (10HA/16879)	3 ft. 3 in.	*Recv. R4187 (4N)	Power and radio unit (3N)	<i>Pin to Pin</i> Wire 6145-100249 to Pin No. 1. Wire 6145-100179 to Pin No. 2, 3, 4. Screen to pin 2.
7	E496/50F/R4 (10HA/16880)	†5 ft. 9 in.	*Power and radio unit (3P)	Power supply	
8	E14/30B/R4 (10HA/15346)	1 ft. 6 in.	Recv. 4187 (4AD)	J. Box 4191 (12AD)	Pin to Letter Consecutive 25 Metvinsmall 2-5.
9	EB14/30B/R6 (10HA/16882)	3 ft. 9 in.	Control unit 4190 (1AE)	J. Box 4191 (12AE)	Pin to Letter Consecutive 25 Metvinsmall 2-5.
10	E14/20C/R6 (10HA/16883)	1 ft. 9 in.	**Control unit 4190 (1AF)	Selector unit (13AF)	Pin to Pin 1-25. 25 Metvinsmall 2-5.
11	EB31/30B/R3 (10HA/16884)	5 ft. 3 in.	**Selector unit (13AA)	Aerial control unit 7216 (14AA)	Pin to Letter Consecutive 18 Metvinsmall 2-5.
12	EB14/30B/R7 (10HA/16885)	16 ft. 6 in.	**Selector unit (13AB)	Break (AB) plug 489	Pin to Letter Consecutive 25 Metvinsmall 2-5 (cores not required cut back).
13	B14/20A/R2 (10HA/16892)	59 ft. 0 in.	Aerial tuning unit (15AB)	Break plug 489	

RESTRICTED

(Table 5—contd.)

Item in Fig. 4	Identity sleeve marking Type and Ref. No.	Overall length of cable	Destination sleeve marking		Remarks
			End A	End B	
14	D270/30C/R6 (10HA/16886)	5 ft. 6 in.	Control unit 4190 (1B)	Trans. T4188 (2B)	Uniradio 70.
15	D265/30C/R6 (10HA/16887)	6 ft. 0 in.	Control unit 4190 (1C)	Trans. T4188 (2C)	Uniradio 65.
16	D265/30C/R7 (10HA/16888)	1 ft. 6 in.	Power radio unit (3E)	Trans. T4188 (2E)	Uniradio 65.
17	D270/30C/R7 (10HA/16889)	2 ft. 9 in.	Control unit 4190 (1L)	Recvr. R4187 (4L)	Uniradio 70.
18	D265/30B/R2 (10HA/16890)	17 ft. 0 in.	**Control unit 4190 (1AG)	Break plug 490	Uniradio 65.
19	D265/30B/R3 (10HA/16891)	59 ft. 0 in.	Break plug 490	Imp. match. (16AG)	Uniradio 65.
20	B12/20B/R3 (10HA/16893)	3 ft. 6 in.	Imp. match. unit (16AC)	**Aerial tuning unit (15AC)	12 Metvinsmall 2-5.
21	B14/20A/R3 (10HA/16894)	8 ft. 6 in.	J. Box 4191 (12AH)	Control unit 4189 (11AH)	25 Metvinsmall Pin to Pin 1-25.
22	E497/50F/R4 (10HA/16895)	Dupren 35 5 ft. 6 in. Unipren 12 0 ft. 6 in.	*Voltage regulator	Supply	
23	D243/50E/2 (10HA/14171)	4 ft. 0 in.	**Imp. match. unit (16AL)	Probe	Uniradio 43.

Note . . .

- (a) Cables marked * are made up cables in polythene sleeving as there are no miniature cables in use which would meet the requirements.
- (b) Cable marked ** are for suppressed aerial installations only.
- (c) Cable lengths marked † include cut-back of 3 in. or 6 in. at the End B.

RESTRICTED

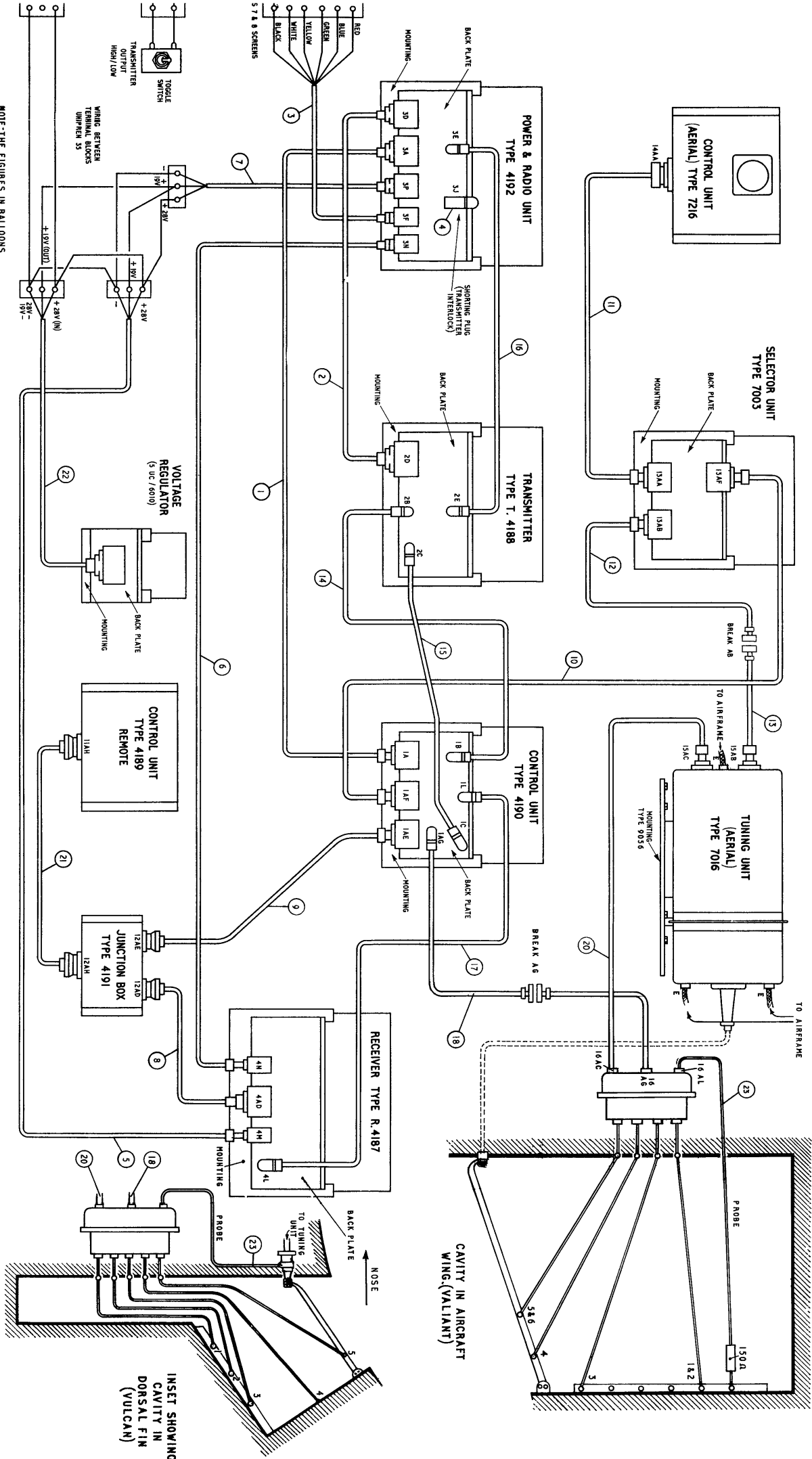

NOTE: THE FIGURES IN BALLOONS REFER TO CONNECTOR INFORMATION IN TABLES 4 & 5

ARI. 5874 with suppressed aerial system Type 9502-Valiant & Vulcan
R E S T R I C T E D

Fig 4

(A.L.42 April 57)

Chapter 1

TUNING UNIT (AERIAL) TYPE 7180

LIST OF CONTENTS

	Para.		Para.
Introduction	1	Circuit description	
Construction	2	RF circuit	11
Front panel	6	Monitoring of aerial excitation	12
Rear panel	9	Control circuits	16
		Tuning motors and "Wheatstone Servo" circuits	22

LIST OF TABLES

	Table
Major operating components of tuning circuits (follows para. 43)	1

LIST OF ILLUSTRATIONS

	Fig.		Fig.
Tuning unit (aerial) Type 7180—front panel	1	Tuning unit—underside	4
Tuning unit—left side of chassis	2	Tuning unit—rear panel	5
Tuning unit—right side of chassis	3	Tuning unit (aerial) Type 7180—circuit	6

INTRODUCTION

1. The aerial tuning unit Type 7180 provides an impedance matching π -network between the transmitter and the complex impedance presented by a fixed wire aerial. The unit contains two variable inductors and a selection of fixed capacitors operated by three remote control elements.

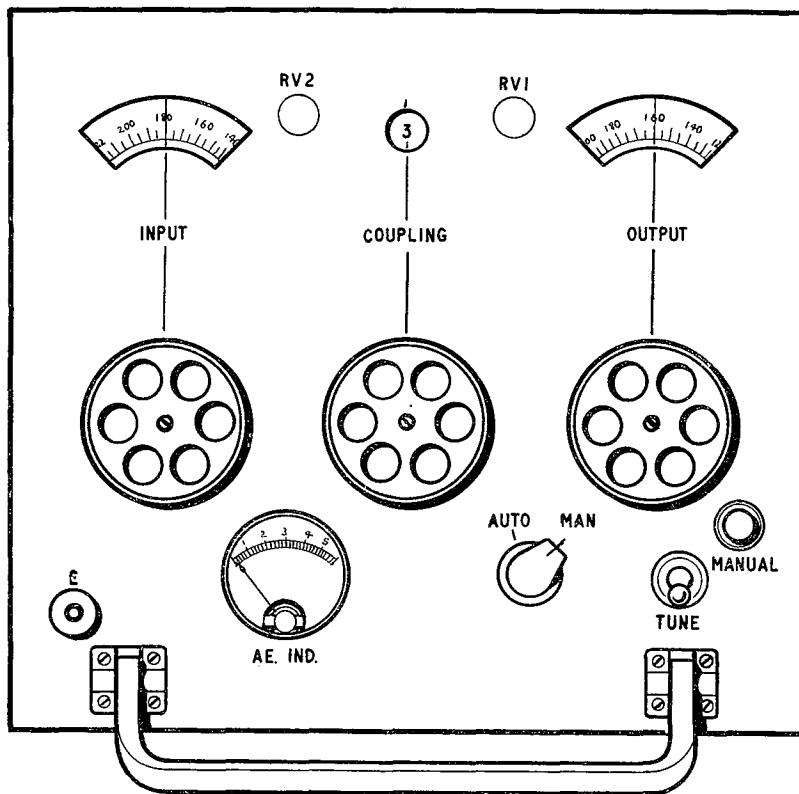

Fig. 1. Tuning unit (aerial) Type 7180—front panel

CONSTRUCTION

2. The components are mounted on a rectangular angle-framework with a shallow chassis base. All the manual controls are mounted on the front panel (fig. 1) and connections to the other units of the equipment are made via one multi-pin and one coaxial plug on the rear panel, the connection to the aerial is made via a polythene plug on the rear panel.

3. A removable dust cover (cover Type 1028—10AP/257) is fitted over the complete chassis and is fixed by an Oddie fastener at the rear. The front panel measures 8 in. by 8 in. and the length of the chassis is 12.5 in.

4. On the left and right hand sides of the rear of the base chassis are mounted the input and output variable inductors L1 and L2 (fig. 2 and 3). These coils are connected through the "anti-inertia" couplings to the front panel controls and to the driving motors. Above these coils, on the centre line, are mounted the fixed capacitors C1 to C6 and the associated switch S3.

5. The space between the coils is occupied by the relays of the bridge circuits operating the motors.

RESTRICTED

Front panel

6. A sub-panel on which the front panel is mounted, bears the three balancing potentiometers of the remote control circuits with the gearing between these and their respective manual control knobs and motors. The motors are mounted at the bottom of the unit below the gearing and are jointly disengaged from the gear trains when the AUTO-MAN switch is at the MAN position. The motors are held in pivoted cylindrical housings and can be removed from these by withdrawal from the underside.

7. The three motors MG1, MG2 and MG3 and the associated components are part of drive unit mechanical Type 7510 (fig. 2).

8. The front panel has the following controls, all for use on manual operation.

- (1) Three tuning knobs and the associated dials—INPUT, COUPLING and OUTPUT.
- (2) Two switches—AUTO-MAN and TUNE.
- (3) A meter M1 giving indication of aerial excitation. (AE. IND.)
- (4) Two variable resistors RV1 and RV2 for preset adjustment of the aerial monitor circuit.

- (5) A red lamp which is illuminated when the AUTO-MAN switch is at MAN.

Rear panel

9. At the rear of the unit, close to the high potential output plug PL3, is mounted the aerial excitation monitor circuit, which includes the components associated with M1. The rear panel is fitted with the following plugs (fig. 5):—

- (1) PL1—coaxial plug—Transmitted RF input.
- (2) PL2—28-way plug—Control circuits.
- (3) PL3—High voltage plug—Output to wire aerial.

Note . . .

The component group associated with the aerial excitation monitor circuit is accessible after the removal of the screws securing the rear panel. On no account must the screws securing the 28-way plug PL2 be removed since this will disturb the alignment of the plug with the associated socket in the back-plate. For further information see Chap. 3.

10. The underside of the base chassis displays the control relay connections and mounts the associated components (fig. 4).

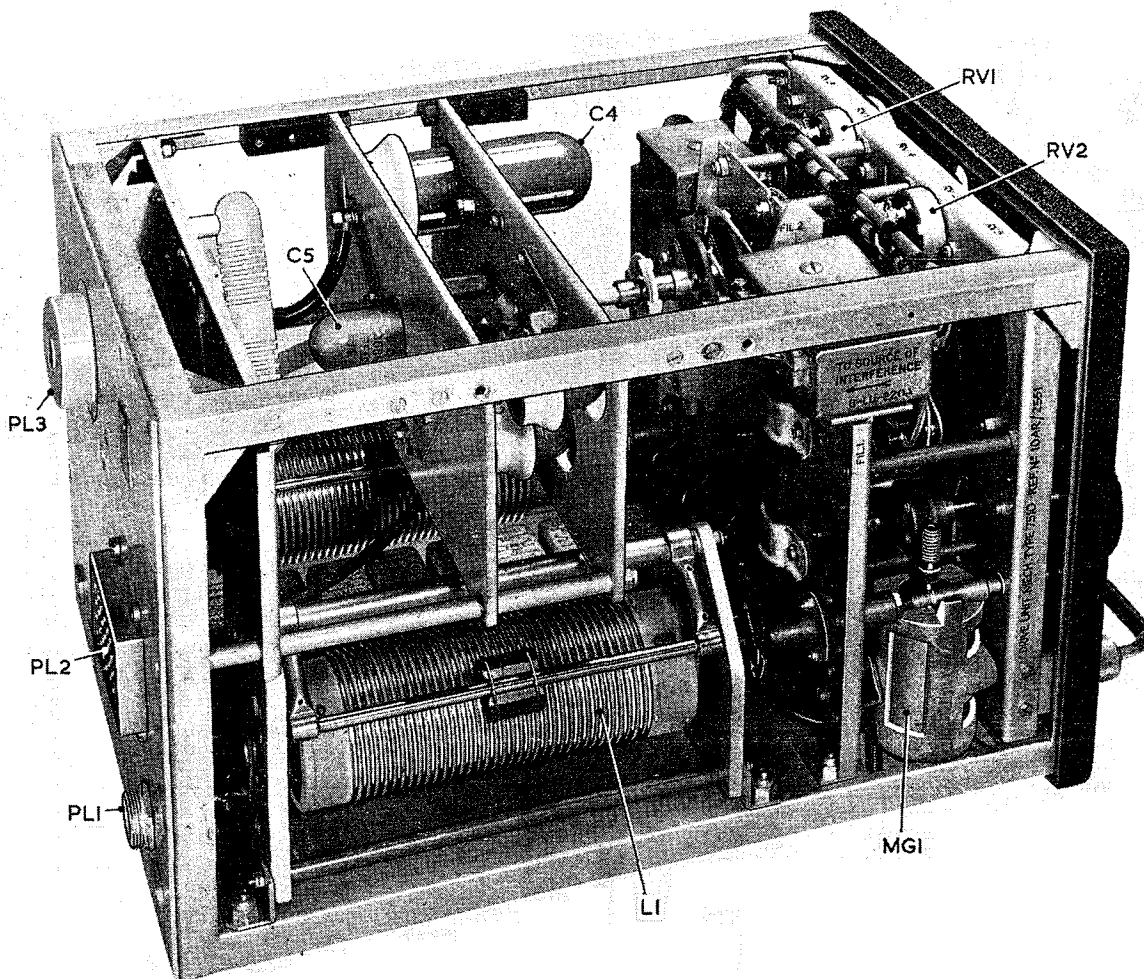

Fig. 2. Tuning unit—left side of chassis

RESTRICTED

CIRCUIT DESCRIPTION**RF circuit**

11. The unit employs a π -network to match the 70-ohm resistance output from the transmitter to the complex impedance of a wire aerial. L1 is the input shunt element, one of the capacitors C1 to C6 the series element, and L2 the output shunt element (fig. 6). The transmitter output is connected to PL1 and the aerial to PL3.

Monitoring of aerial excitation

12. A toroidal coil, wound on an iron dust core and mounted in a "gapped" screen insulated from chassis forms an aerial current transformer T1; the aerial lead which passes through the centre being in effect a "single turn" primary. The secondary output shunted by R1, is rectified by the germanium rectifier W2 and the current in the load consisting of RV3, RV1 in series is measured with the meter M1.

13. A capacitance potential-divider formed by the insulated coil screen and C7 connects a fraction of

the aerial potential to a second germanium rectifier W1, the rectified current then being measured again by M1 in series with R2 and RV2. The meter M1 will therefore read an indication of aerial current plus aerial potential.

14. Thus on a low impedance aerial the meter will give an indication mainly of aerial current, while on a high impedance aerial an indication mainly of aerial voltage is obtained. This ensures that a good indication of aerial excitation is given no matter what the aerial impedance.

15. Potentiometers RV1 and RV2 facilitate the adjustment of the circuit for a particular aerial. Generally these will be set so that the meter scale represents amps and kilovolts. The indication is given either on M1 on the aerial tuning unit or remotely, dependent upon the position of the AUTO-MAN switch; in the second event a separate earth wire is used via pin 26 of PL2 to avoid interference with the indication from earth currents

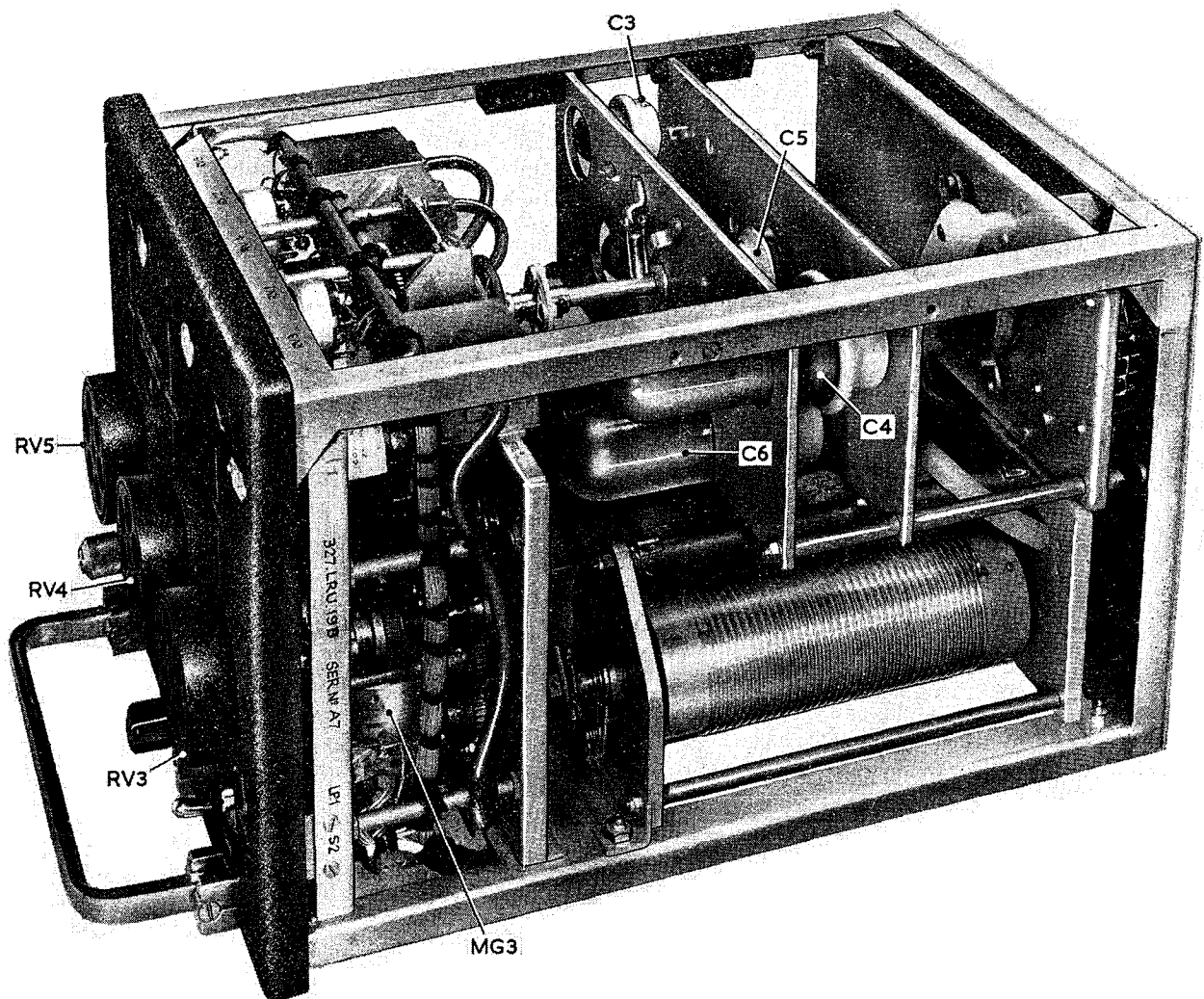

Fig. 3. Tuning unit—right side of chassis

RESTRICTED

due to the control circuits flowing in a common earth line.

Control circuits

16. The three motors MG1, MG2 and MG3 are remotely tuned by the settings of the associated potential dividers in the control unit Type 4243 (*Chap. 2*). The relay circuits of these motors are described in para. 22 to 43. The 28-volt supply for the motor relays is obtained from PL2/5. Motor MG2 operates three ganged switches S3A, S3B, S3C.

17. Switch S3B selects the series capacitor, S3A indicates to the control and drive unit which capacitor is selected by earthing one of the six signal wires of pins 20-25 on PL2, and S3C renders the TUNE switch S2A inoperative except when the contact of S3B is on a capacitor position. This avoids S3B making or breaking RF potentials.

18. Switch S1A-B has two positions. In the AUTO position the tuning unit is controlled remotely; S1A connects the output of the aerial monitor circuit to the remote meters via pin 6 on PL2 (AE IND); S1B connects the 19-volt supply to the remote bridge circuits of this unit from the drive unit.

19. In the MANUAL position, the meter M1 is connected to the monitoring circuit by S1A; switch S1B removes the bridge circuit supply to the drive unit at SK2/7 and a cam coupled to S1 disengages the mechanical drives from the tuning motors to the tuning elements (L1, C1 to C6, L2).

20. This arrangement allows manual tuning for initial setting up with a fixed aerial. The MANUAL

condition is also marked by the switch S1B switching on MANUAL lamp LP1, indicating that remote control has been removed. The manual adjustments are made by use of the three front panel dials INPUT, COUPLING and OUTPUT, and the TUNE switch S2 (*fig. 1*).

21. The "rest" position of the spring-loaded TUNE switch S2 is the normal operating position (unmarked). In the spring-loaded position TUNE the key circuit is made by earthing pin 11 of PL2 via S2A and S3C. At the same time the "safe" condition is introduced by earthing the SAFE line at pin 17 of PL2. The TUNE switch thus allows a check to be made of the tuning unit in either positions of the AUTO-MAN switch S1.

Tuning motors and "Wheatstone Servo" circuits

22. The three servo systems used to drive the tuning motors MG1, MG2 and MG3 are identical with the exception of the component circuit reference numbers (*fig. 6*). All three circuits are similar to those used for the receiver and transmitter tuning.

23. Each servo system has two functions. The first is to turn the motors by remote control to tune up the aerial tuning unit from the control and drive unit (control unit Type 4243). The second is to provide a means of returning to these chosen tuning conditions when selection of a frequency channel is made.

24. The tuning circuit is described as a "Wheatstone Servo" and is fundamentally a self-balancing bridge. The circuit for all three tuning motors is described in the following paragraphs by reference

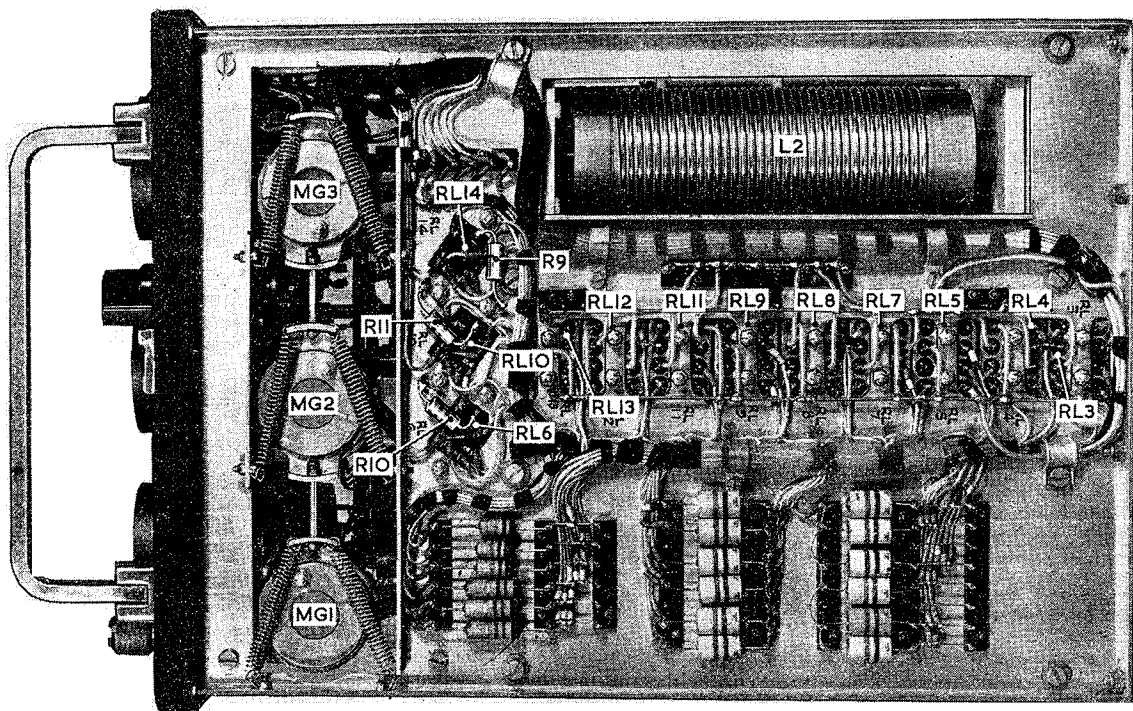

Fig. 4. Tuning unit—underside

RESTRICTED

to the circuit consisting of tuning motor MG1 and the motor-balancing potentiometer RV5 (etc.).

25. The setting potentiometer POT.3 (or POT.4) in the control unit Type 4243 (*Chap. 2*) is coupled by connectors to the motor-balancing potentiometer RV5. The bridge is supplied with 19V except when the equipment is in the MANUAL condition and when the selector motor in the control and drive unit is running.

26. A separate earth wire on the bridge, earthed at one end only (control earth) is used to avoid other DC earth currents affecting the centre-stable relay RL6/1.

27. The wiper of POT.3 is taken via pin 8 (control det.) of PL2 through the relay contact RL5A to the 110-ohm winding of the sensitive relay RL6/1, and thence to the wiper of RV5 driven by gearing from the tuning motor MG1.

28. When the bridge is unbalanced, relay RL6/1 operates and closes contacts 6A. Since the contacts of this relay cannot handle the motor current, contact 6A is arranged to energize the slave relays RL3/2 and RL4/2 from the 28V supply.

29. If the unbalance of the bridge is such that the direction of movement of contact 6A causes the relay RL3/2 to be energized, contacts 3A and 3B close. The 28V supply is then taken via contacts 4A and 3B to one side of the motor M, which being earthed on its other pole via contacts 4B and 3A starts to rotate (the motor has a permanent-magnet field).

30. When the bridge is restored to its balanced condition, contact 6A returns to the centre position and relay RL3/2 is released. Contact 3B then short-circuits the motor armature, thus providing a braking action to prevent over-run of the motor.

31. If relay RL4/2 is energized by reason of the position of the relay contact 6A, the contacts 3B and 4A will apply the battery supply to the motor in the reverse direction to that described in para. 26. The direction of the rotation of the motor will then of course, be reversed.

32. Since the sensitive centre-stable relay RL6/1 operates with an energizing current of approximately 200 microamperes, the 110-ohm winding must be protected from overload when the bridge is well out of balance. A Thermistor or non-linear resistance, W3 is connected in series with the safety relay RL5/2 and both are connected across the 110-ohm winding of RL6/1.

33. In conditions of overload the non-linear resistance falls to a low value and sufficient current passes to energize the safety relay, thus opening contact 5A and placing the resistor R4 in series with the sensitive winding to protect it.

34. At near balance conditions the contact 5A

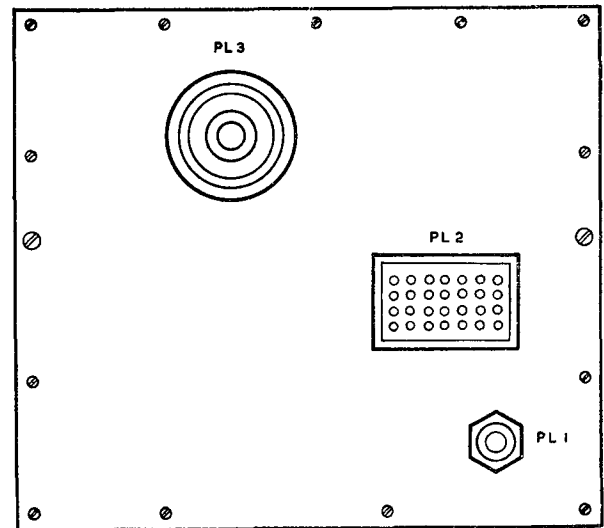

Fig. 5. Tuning unit—rear panel

closes and thus restores the centre-stable relay to its full sensitivity.

35. The relay contact 6A is protected by the spark quench rectifiers W6 and W7, which also slow the release of the slave relays RL3/2 and RL4/2. The spark quench rectifiers W4 and W5 are connected across the motor to protect the contacts 3A, 3B, 4A and 4B.

36. Unless certain precautions are taken the system as described in the foregoing paragraphs will tend to "over-shoot" the balance point and then hunt before coming to rest. "Over-shoot" and the consequent hunting is prevented by the inclusion of an "anti-hunt" circuit using a 45-ohm second winding on the centre-stable relay RL6/1. This will be described as a "feed-back" circuit, although the action is not as is generally understood by this term.

37. Assume that the motor is moving towards the balance point with relay RL3/2 energized; contact 3B closed (22-23); the positive potential at the motor pole (relay contact 3B) is applied through the second winding of 45-ohms on relay RL6/1 through the feedback resistance R5 to earth at 3A. The mode of action of the 45-ohm winding is in opposition to that of the detector winding so that relay RL6/1 will reach its neutral position to stop the motor before the actual balance point is obtained.

38. In this condition, the feedback winding no longer has any effect since the positive supply is removed by the movement of relay contact 3B, however, the out-of-balance current still flows through the 110-ohm winding because the true balance point is not yet reached.

39. The sensitive relay RL6/1 thus closes once again to indirectly operate relay RL3/2 but as the effect of the 45-ohm winding is now greater the contacts 3A and 3B are immediately thrown off.

RESTRICTED

These conditions are repeated until the unbalance current falls below the operating value of the 110-ohm winding of RL6/1 and thus equilibrium is reached.

40. If the motor had been energized through the closed relay contact 4B, the feedback direction would then have been from 4A to 4B, thus still in opposition to the action of the 110-ohm winding. In practice, this causes the slave relays to run the motor to a point just before balance and then "tick" into the rest position. If overshoot occurs owing to varying loads on the motor, the feedback circuit greatly reduces the duration of hunting.

Note . . .

Relay contacts RL5B, RL9B and RL13B are not in use, but may be used in servicing to check the operation of these relays.

41. "Hash" filters are fitted to each pole of the tuning motor and are enclosed in a screened box

FIL. 1. When the motor is running one of the contacts 4B or 3A of the slave relays will be operated and will earth the TUNE line. This indicates on a TUNE lamp on the control unit Type 4243 and the remote control unit, that a tuning motor is operating and normally prevents the key placing the transmitter on "mark". The latter function is more fully described in Section 1.

42. To prevent the control system driving the motors until the mechanical rotation limit-stops on the associated driven components are reached, it is necessary to arrange electrical stops inside the rotation limits. This is achieved by limiting the wiping length of the 12-way setting potentiometers in such a way that a small portion of the resistance is always left in circuit. The limitation ensures that the balancing potentiometer RV5 will always reach balance before the end of its travel.

43. The components used in the bridge circuits are tabulated against the function of the tuning motors in Table 1.

TABLE I
Major operating components of tuning circuits

Function of tuning motor		Component reference					
		12-Way pot	Motor	Balancing pot	Slave relays	Detector relay	Safety relay
Transmitter (Sect. 1)	RF stages	POT. 1 (1A-1M) } POT. 2 (2A-2M) }	2MG1	2RV1	2RL8 2RL9	2RL6	2RL7
		Control unit Type 4243					
Aerial tuning unit	Input	POT. 3 (1A-1M) } POT. 4 (2A-2M) }	8MG1	8RV5	8RL3 8RL4	8RL6	8RL5
	Coupling	POT. 5 (1A-1M) } POT. 6 (2A-2M) }					
	Output	POT. 7 (1A-1M) } POT. 8 (2A-2M) }	8MG3	8RV3	8RL11 8RL12	8RL14	8RL13

RESTRICTED

PL1 (R)

RF INPUT

C1 10p
C2 25p
C3 40p
C4 150p
C5 400p
C6 100

S3B

UNIT PREFIX No. (8)

A.P.2535E, Vol. I, Part I, Sect. 3, Chapp. 1
A.L.56, Jan. 63

PL3 (R)
TO AERIAL

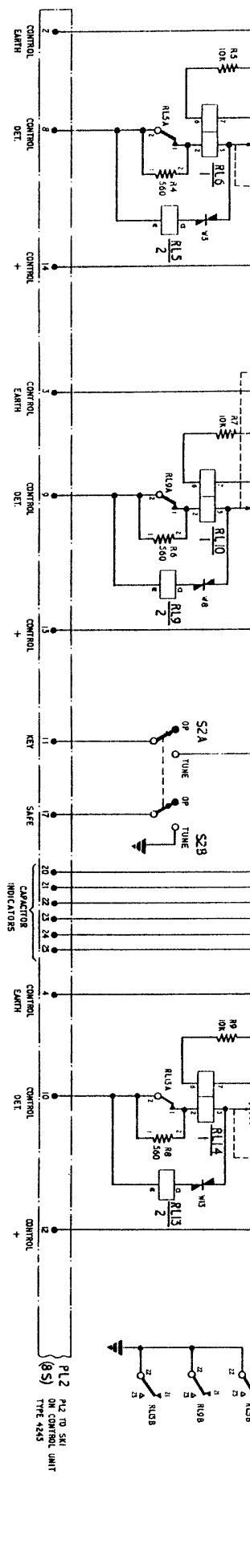
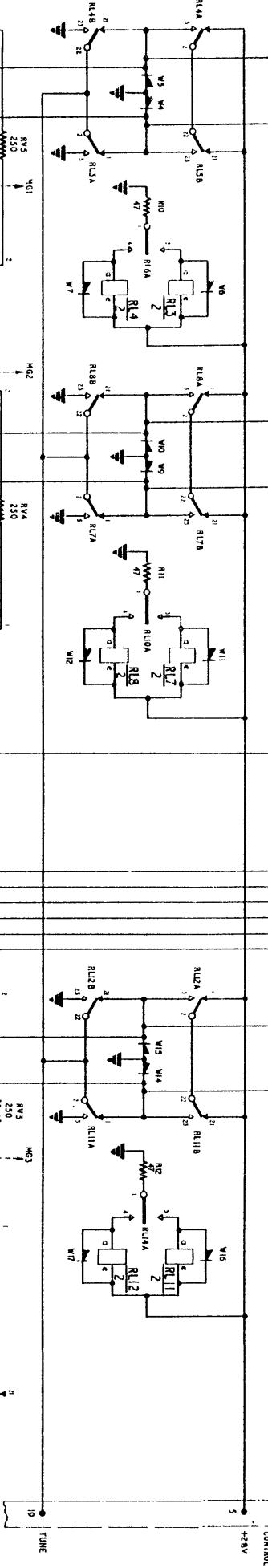
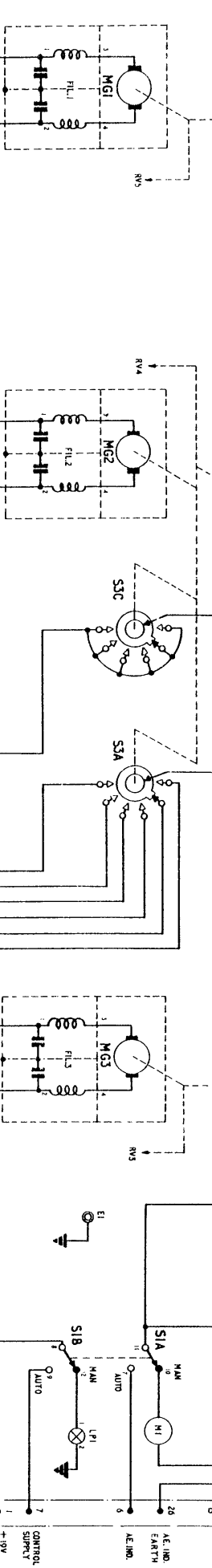
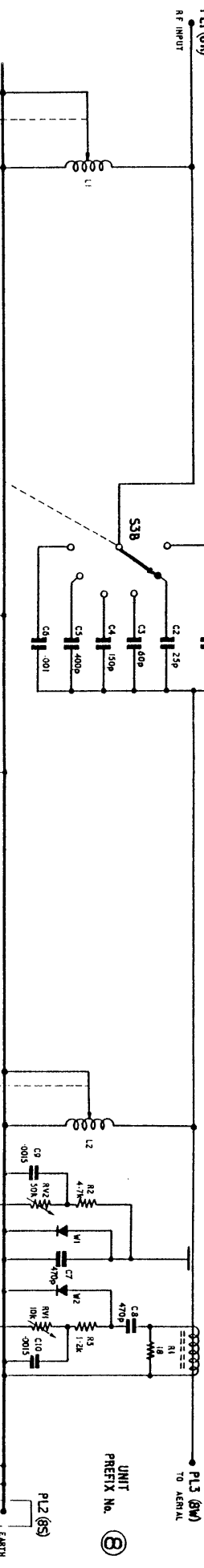

AIR DIAGRAM
6103K/MIN.

ARI.5874 - Tuning unit (serial) Type 7180 - circuit

RESTRICTED

FIGURE 2
PP9119 2006/470926 2.55 C.A.P.

Fig 6

Chapter 2

CONTROL UNIT TYPE 4243

LIST OF CONTENTS

	Para.		Para.
Introduction	1	Front panel switches	
Construction	2	Meter switch (S1)	24
Front panel controls and switches	3	TEST/TUNE switch (S4)	25
Chassis layout	7	Band switches (S2/1 and S2/2)	26
Circuit description	15	TUNING lamp (LPI)	28
Oscillator unit Type 4215	17	Selector circuit switches and relays	
Crystal units	22	Selector switches (S3)	29
Control circuits	23	Relays	30
		Motor relays	31
		Number relays	34
		Aerial or "keying" relay	35
		Low power or "safe" relay	39
		Capacitor indicating lamps	40

LIST OF ILLUSTRATIONS

	Fig.		Fig.
Control unit Type 4243—front panel	1	Rear panel of control unit	4
Control unit chassis—underside	2	Block schematic of control and drive unit	5
Control unit chassis	3	ARI.5874—Control unit Type 4243—circuit	6

INTRODUCTION

1. The control unit Type 4243 is used in aircraft installations of the ARI.5874 with fixed wire aerial systems; for those aircraft fitted with ARI.5874 using suppressed aerals, control unit Type 4190

is used, this is described in Sect. 1, Chap. 3. The control unit Type 4243 is the control and drive unit of the transmitter (when using a wire aerial) and includes all the control circuits necessary to operate the transmitter and the aerial tuning unit.

The unit is better known as "the control and drive unit."

CONSTRUCTION

2. The chassis is constructed as a rectangular framework on which a detachable front panel is mounted. A loose dust cover is fitted and can be removed from the rear of the chassis after the release of an Oddie fastener.

Front panel controls and switches

3. An illustration of the front panel of the control and drive unit is given in fig. 1. The panel is fitted with controls which in conjunction with the remote control unit can be used to set up channels on any frequency in the band without access to the transmitter or the aerial tuning unit. These channels can then be selected at the remote control unit.

4. The upper half of the front panel gives access to a group of eight 12-way potentiometers and

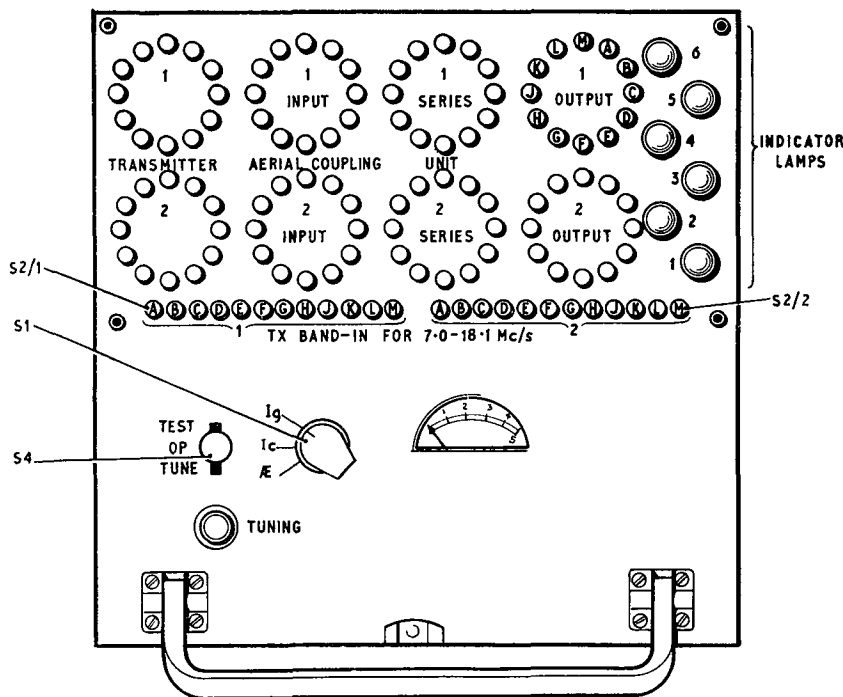

Fig. 1. Control unit Type 4233—front panel

RESTRICTED

mounts six capacitor position lamps. The potentiometers and associated mounting plate may be withdrawn through the front panel.

5. Beneath the potentiometers and the lamps is mounted an assembly of 24 frequency band switches used for setting up. The assembly is known as switch unit Type 7289 (10F/17582) and consists of single-pole switches of the push button type. The switches in the normal position are "OFF." Twelve of the switch knobs are in white perspex (S2/1) and the remaining twelve in black ebonite (S2/2). The two rows of knobs are engraved A-M in each case.

6. The detachable front panel (panel, control Type 7509—10D/19280) may be unplugged from the remainder of the chassis after releasing a number of securing screws. This allows access to the front part of the chassis for servicing purposes.

Chassis layout

7. A selector motor (motor unit Type 4214) is mounted in the centre of the chassis and drives a shaft operating a 7-way multibank switch S3 (fig. 2) from which is made all the switching necessary for automatic channel selection of the transmitter and aerial tuning circuits.

8. Three banks of the switch (S3A-B-C) associated with the control wiring are mounted at the front. Four banks, (S3E-F-G-H) at the rear and in the space between the two vertical banks of the crystal sockets, are used to select one of the 24 crystals for each channel.

9. A gear train from the same motor shaft engages

with a gear train at the rear of the eight 12-way potentiometers (fig. 3) and thus turns these in unison to the selected channel position.

10. Above the crystal sockets is mounted the sub-chassis of the crystal oscillator (oscillator unit Type 4215), connection being made to the crystal switches by means of spring contacts. Behind the crystal oscillator are four sealed relays, part of the control circuit (para. 12).

11. Two crystal ovens, Type 13 and Type 14, house the 24 crystal units which are switched-in by the channel selection system and applied to the crystal oscillator circuit. The ovens are fitted with heaters and thermostatic control which keeps the crystal temperature at about 10 degrees C. (nominal).

12. A number of relays are fitted to the control unit chassis, one of which is the low impedance aerial changeover relay which changes the feed cable to the aerial tuning unit from the receiver to the transmitter, when the key is pressed. The key relay is mounted on a panel at the rear of the chassis and is designated relay unit Type 4216. Three coaxial plugs are connected to this relay, thus enabling the aerial to be connected through the relay to either the transmitter or the receiver (para. 15).

13. On the rear panel of the unit (fig 4) are mounted plugs and sockets for interconnection with other units of the installation, the connections are made through the back-plate of the unit. (Chap. 3.)

14. The back-plate is interconnected to the

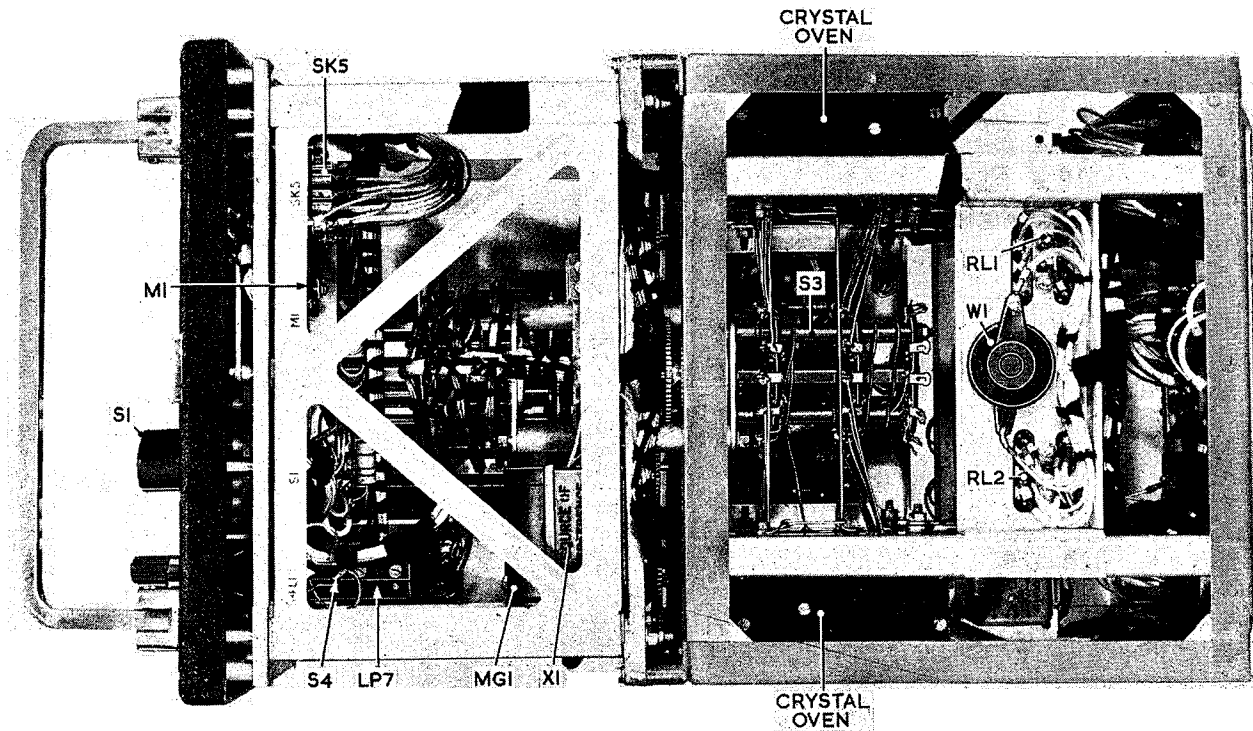

Fig. 2. Control unit chassis—underside

RESTRICTED

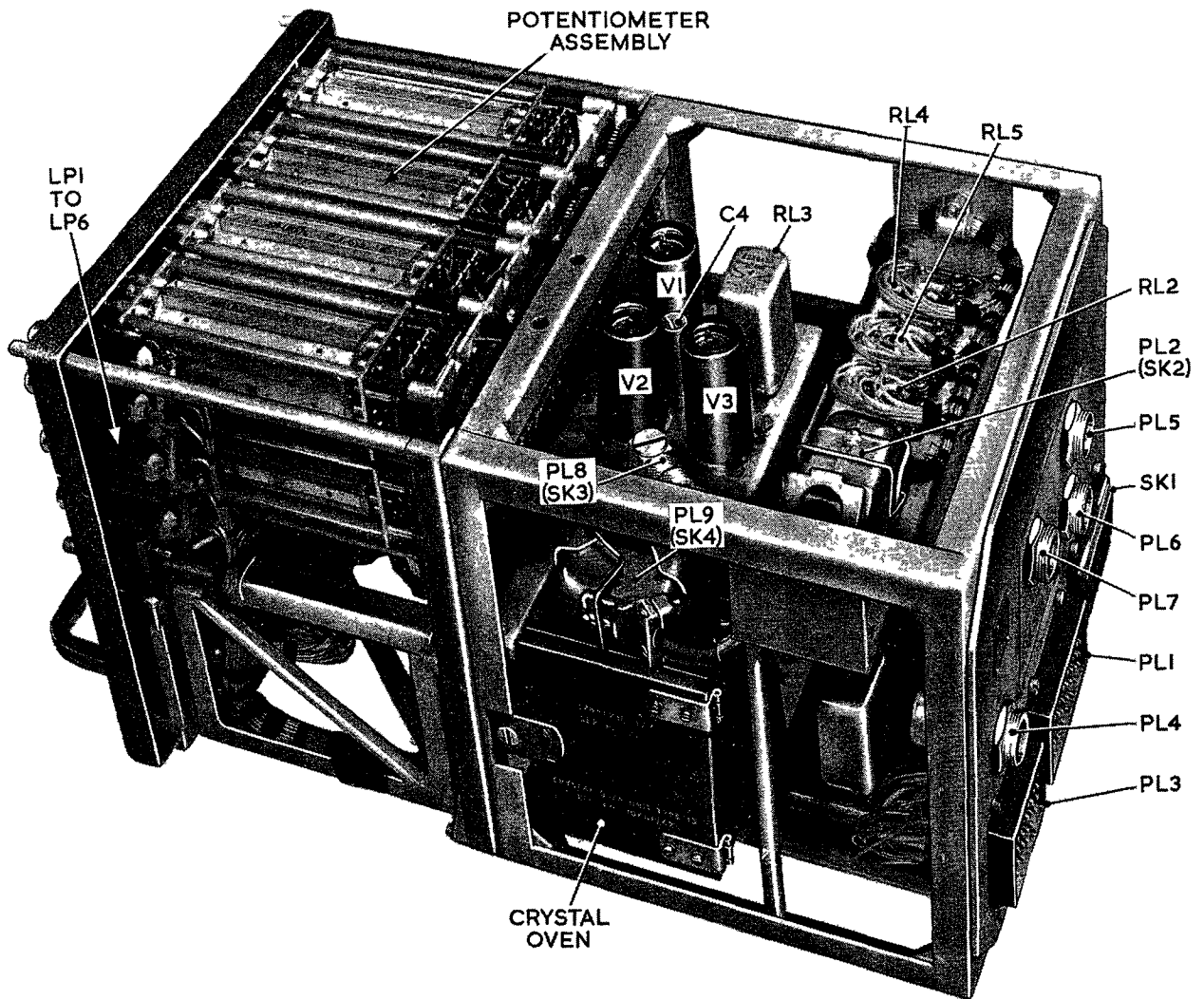

Fig. 3. Control unit chassis

remainder of the installation by means of connectors permanently wired to the back-plates of other units of the installation. Some details of the plugs and sockets at the rear of the control unit Type 4243 are given below; a more complete account is given in Chap. 3.

- (1S) SK1—28-way socket Channel selection control to aerial tuning unit Type 7180.
- (1AE) PL1—28-way plug Connections to remote control unit Type 4189 through junction box Type 4191.
- (1A) PL3—20-way plug Control and power supplies from power and radio unit.
- (1B) PL4—coaxial plug Crystal oscillator output to transmitter.

- (1C) PL5—coaxial plug Aerial connection to transmitter.
- (1R) PL6—coaxial plug Connection from aerial tuning unit to aerial changeover relay (*para.* 12).
- (1L) PL7—coaxial plug Aerial connection to receiver.

Note . . .

The references in brackets refer to the back-plate and connector coding (Chap. 3).

CIRCUIT DESCRIPTION

15. The circuit of the control unit Type 4243 includes those parts of the transmitting circuit controlling the signal frequency and channel selection. The control unit also includes the tuning potentiometers and the capacitor indicating lamps of the aerial tuning unit.

RESTRICTED

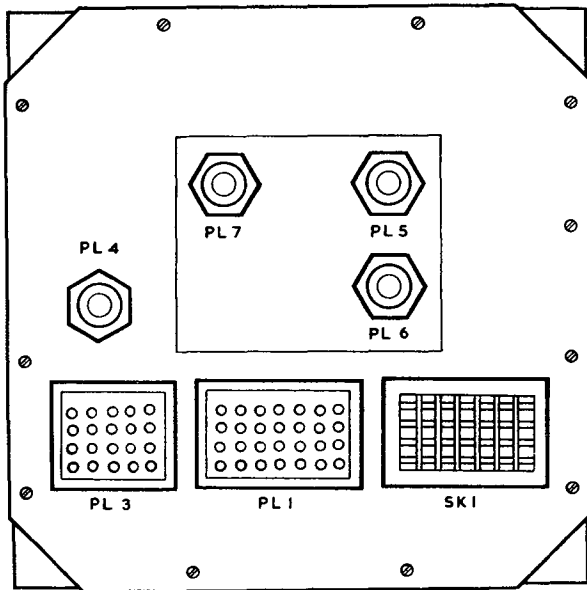

Fig. 4. Rear panel of control unit

16. A complete circuit diagram is given in fig. 6. The circuit can be divided into four parts, three of which are indicated in the block schematic fig. 5.

- (1) The crystal-controlled oscillator.
- (2) The channel selector motor and channel selection circuits.
- (3) The transmitter metering circuits (fig. 6).
- (4) The aerial system tuning potentiometers and capacitor indicating lamps circuit.

Oscillator unit Type 4215

17. The oscillator unit Type 4215 includes three HF pentodes CV138. The oscillator V1 is triode-connected in an aperiodic Colpitts oscillator with feed-back provided by the capacitors C1 and C2.

18. Any one of the 24 crystals can be connected between grid and earth of V1, the selection being made as follows. The crystals are in two banks of twelve; those for the channels 1A-1M are selected by switch wafers S3E and S3F; S3E earthing all crystals with the exception of the one selected while S3F makes contact only with the crystal selected.

19. Switch wafers S3G and S3H operate similarly on the other crystal bank. Contact 3A of relay RL3/2 connects the oscillator grid to one or other of the crystal banks, the bank not in use being earthed by contact 3B.

20. The anode of V1 is coupled by C5 and R7 to the grids of the valves V2 and V3 connected in parallel and as a cathode-follower with load R10, R11. The output through C6 is taken to plug PL4 at the rear of the control unit Type 4243 via SK3 on the oscillator chassis and is a nominal 2 volts RMS into a cable of 70 ohms impedance.

21. The valve heaters are connected in series with the 19V supply. The 300V supply to the anodes is connected via PL9 and SK4 and obtained from the keying relay 2RL4/2 in the transmitter unit (via relay 3RL1/2 in the power and radio unit).

Crystal units

22. Each bank of 12 crystal units is plugged into an enclosure or oven which is thermostatically controlled to a temperature about 10 degrees C. (nominal) by means of heaters R15 and R16. The

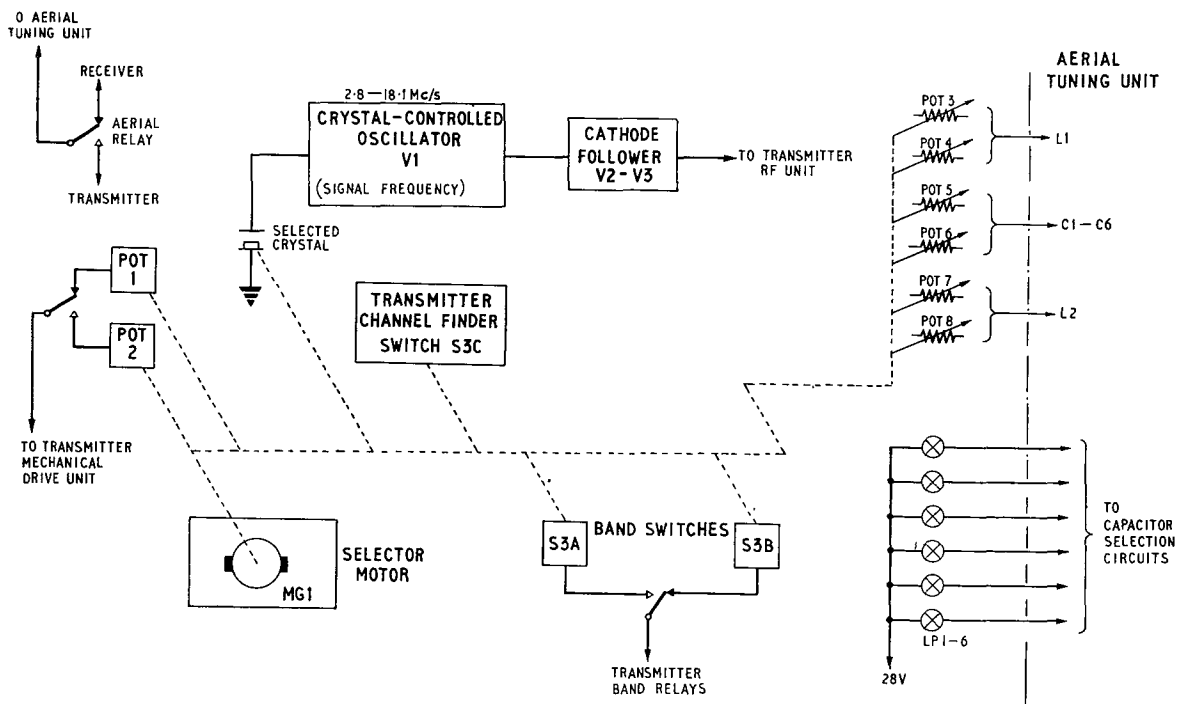

Fig. 5. Block schematic of control and drive unit

RESTRICTED

latter are switched in by the bimetal regulators X2 and X3.

Control circuits

23. A full description of the channel selection and control circuits is given in Chap. 7 of Sect. 1, but a brief description of the control and switching circuits of the transmitter is given below:—

Front panel switches

Meter switch—(S1)

24. The meter M1 is connected so that it may be switched to measure the grid current of the transmitter P.A. stage (I_g), the cathode current of the P.A. stage (I_c) and the aerial excitation (AE) from the metering circuit of the aerial tuning unit.

TEST/TUNE switch—(S4)

25. This is a spring-loaded key switch which normally rests in the centre position. The circuit for the three positions is as follows:—

OPERATE (Centre) The “low power” line is open - circuited. (S4D). The “Key” line is open-circuited (S4B).

TUNE (up) The “Key” line is earthed and the aerial changeover relay RL6/2 energized (S4B). The “safe” relay RL7 is earthed (S4D) and the 19V supply is removed from the “intertune” line to allow the transmitter to be adjusted (S4A). The transmitter is switched to R/T by removing the earth from 3RL3 in the power and radio unit (relay contact 7A). Contact 7B removes the earth from the low power line (PL3/20) and allows tuning under “safe” power conditions only, i.e. at nearly full power (*para* 39.)

TEST (down) The earth is removed from the low power line. The “Key” line is earthed (S4C) this allows normal “key down” operation.

Band switches (S2/1 and S2/2)

26. The band switches are selected one per channel by means of the motor-operated switches S3B and S3A respectively. The two groups of switches S2/1 and S2/2 are selected by relay contact 4A and 4B.

27. When the band switches are in the OUT position they switch the 28V supply to the band change relays 2RL1/1, 2RL2/1 and 2RL3/1, thus changing the transmitter tuned circuits from the 7 to 18 Mc/s range to the 2.8 to 7 Mc/s range. (*Sect. 1, Chap. 4*).

TUNING lamp (LPI)

28. The TUNING lamp commences to glow when the TUNE line is earthed, i.e. whenever one of the tuning motors of the transmitter or receiver operates. It is permanently on when the transmitter is switched for MANUAL operation. The TUNE lamp, is of course, visible when the top cover of the front panel is in position and serves as a reminder if the transmitter is left in the MANUAL condition after setting up.

Selector circuit switches and relays

Selector switches (S3)

29. S3A-B As already stated these select the individual band switches of the groups S2/1 and S2/2.

S3C This is the searching bank when the channel is being chosen at the remote control unit. Six wires run from this switch sector to the channel letter pins 1 to 6 on PL1 and thence to the receiver via the junction box; “wire saving” switch banks are used. The method of selection of twelve channels on each band is explained in Chap. 7.

S3J This is a cam-operated clicker switch associated with the channel selector switch S3D. Its operation is explained in Sect. 1, Chap. 7.

S3E-H These select the crystal unit for the channel required.

Relays

30. The relays are grouped by function as follows:—

- (1) Motor relays—RL1/2 and RL2/2
- (2) Number relays—RL3/2, RL4/2, RL5/2 and RL8/2.
- (3) Aerial relay—RL6/2 (low-impedance send-receive aerial switching).
- (4) Low power relay RL7/2 (SAFE).

Motor relays

31. When power is first applied to the control and drive unit, the relays RL1/2 and RL2/2 are energized owing to the earth provided by the connection to S3C or S3J.

32. The motor MG1 starts when 19V is connected via relay contact 1A and rotates until the unearthed position on S3C is reached (“checked” by clicker switch S3J). Relays RL1/2 and RL2/2 then release, thus interrupting the motor circuit (contact 1A), and at the same time, removing the earth from the tune line (contact 1B). The motor is braked dynamically by short-circuiting the armature with contacts 1A and 1B.

33. Relay contacts 2A and 2B make and switch

RESTRICTED

the 19V supply to the tuning head of the aerial tuning unit and the transmitter respectively, this prevents the tuning heads from hunting during the rotation of the selector switch S3.

Number relays

34. The number relays operate when position 2 of the number switch is chosen. Contacts 4A and 4B operate and select the group of band switches S2/2. Relay contact 5A changes control of the transmitter from POT 1 to POT 2. Contacts 5B, 8A and 8B change control of the aerial tuning unit from POT 3 to POT 4, POT 7 to POT 8 and POT 5 to POT 6. These potentiometers control the INPUT, OUTPUT and SERIES controls on the aerial tuning unit. Contacts 3A and 3B change over the crystal groups.

Aerial or "keying" relay

35. The aerial relay RL6/2 is mounted in a fully screened box on the rear panel of the control unit (relay unit Type 4216). Its function is that of an aerial changeover switch. The supply to the relay coil is filtered by means of L1, C9 and L2, C10.

36. If the low impedance of aerial switching is not required for use, the links of TSB (tag strip B) at

the rear of the unit between TSB1 and 3, and TSB2 and 4 should be removed.

37. The low impedance feeder from the aerial tuning unit enters at PL6 and on "space" conditions, contact 6A puts this to the receiver via PL7.

38. On "mark" the aerial is switched by contact 6A to the transmitter output which is connected to PL5; at the same time the receiver aerial is earthed by means of contact 6B.

Low power or "safe" relay

39. The "safe" relay RL7 is operated by the switch 8S2B in the TUNE position at the aerial tuning unit which applies an earth to pin 17 of SK1. Relay contact 7B opens to give "safe" operation and contact 7A opens to place the transmitter on R/T condition by breaking the MCW/RT line at SK1/20. (Switch 8S2A gives "key down" conditions).

Capacitor indicating lamps

40. One of the capacitor indicating lamps LP1 to LP6 indicates the series capacitor selected in the aerial tuning unit when one of the six connecting wires is earthed at that unit by the rotary 6-position switch 8S3A.

RESTRICTED

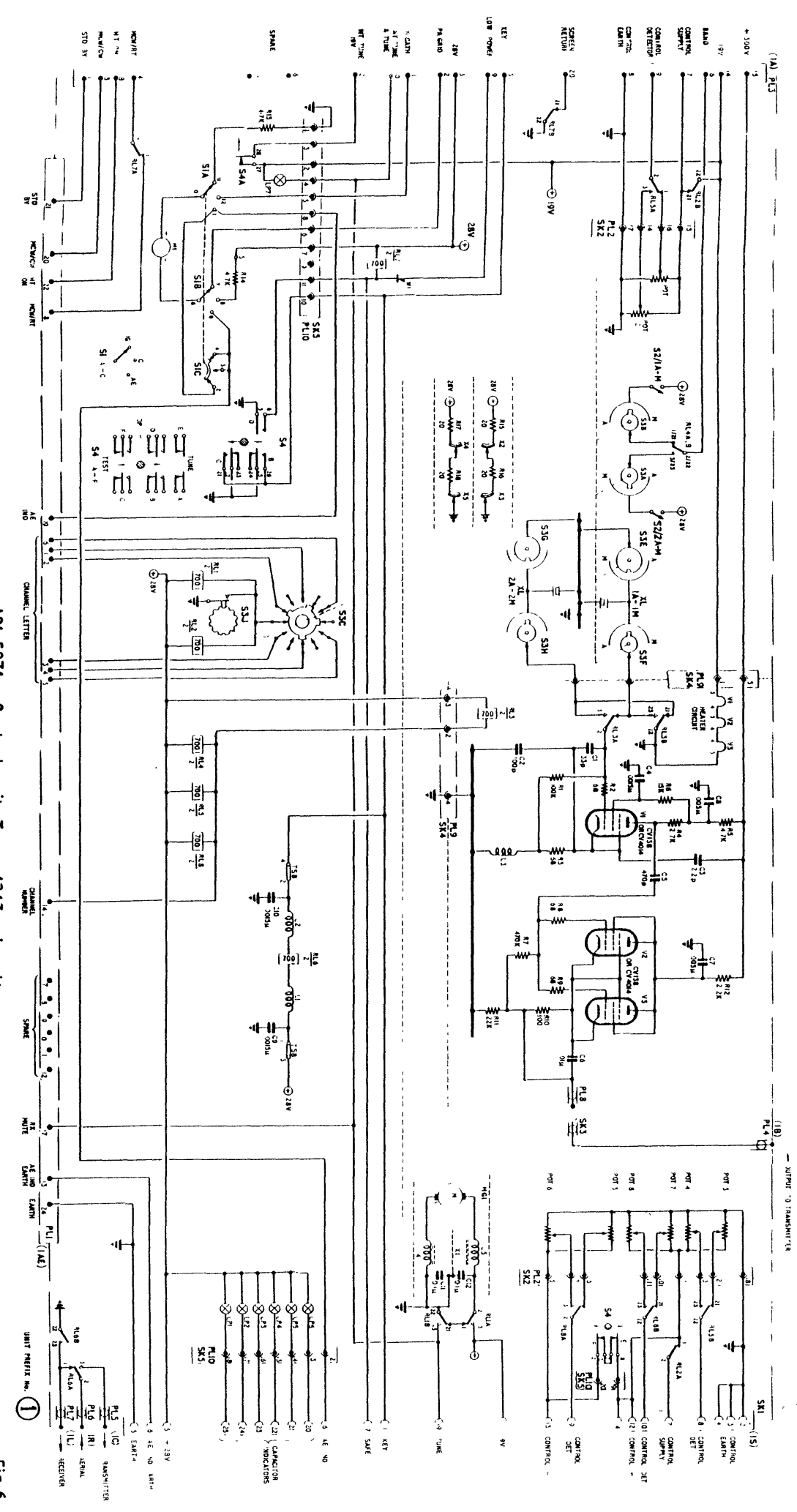

ARI. 5874 - Control unit Type 4243-circuit
RESTRICTED

Chapter 3

FIXED AERIAL INSTALLATION (ARI.5874)

LIST OF CONTENTS

	Para.		Para.
<i>Introduction</i>	1	<i>Fixed equipment</i>	18
<i>Racking system and back-plates</i>	3	<i>Removable equipment</i>	21
<i>Back-plates</i>	8	<i>Connectors</i>	22
<i>Method of fitting back-plates</i>	13	<i>Equipment wires specification</i>	24
<i>Installation and cabling</i>	17		

LIST OF TABLES

	Table		Table
<i>Connector and unit coding</i>	1	<i>Removable equipment</i>	4
<i>Back-plate jigs</i>	2	<i>Connector schedule...</i>	5
<i>Fixed equipment</i>	3		

LIST OF ILLUSTRATIONS

	Fig.		Fig.
<i>Back-plate and connections to rear panel of aerial tuning unit</i>	1	<i>ARI.5874 with fixed wire aerial tuning unit</i>	2

INTRODUCTION

1. The installations described in this chapter are fixed-wire aerial versions of ARI.5874. There will be variant installations for different types of aircraft, the variations being mainly in the lengths of connectors. The provisional connector schedule in Table 5 is for the Beverley aircraft.

2. The main units of the complete installation are described in this Section and in Section 1. The back-plates of the transmitter, receiver and ancillary equipment are described in Chap. 10, Sect. 1. All the connectors, the back-plate of the tuning unit (aerial) Type 7180 and all other installation details are described in this chapter.

RACKING SYSTEM AND BACK-PLATES

3. The construction of the racking system will normally be carried out by the aircraft constructor. The racking conforms with that described in the British Standards Institution publication "Sizes and Forms of Civil Aircraft Radio Equipment".

4. The racking consists of horizontal U-shaped channel members on which are mounted a number of left- and right-side members. The latter are cut to suit the lengths of individual units and positioned on the horizontal members to the width required to accept the unit.

5. Each set of left- and right-side members when mounted on the horizontal members forms a mounting tray for the particular unit. The "rear" ends of the side members are flanged for fitment of the back-plates carrying the plugs and sockets which mate with the associated sockets and plugs on the rear panel of the individual units (*para.* 13).

6. As many units, or multiples of a complement of units, as may be required can be mounted on the racking system. In some aircraft the horizontal members will be mounted in tiers (generally two) one above the other to form a square or rectangular rack.

RESTRICTED

7. The completed racking is mounted on anti-vibration mountings based on a rack loading of 2.5 lb. per inch run. It may be necessary to fit additional anti-vibration mountings to those at the ends of the rack when several heavy units are mounted on the same rack.

Back-plates

8. Interconnection between the individual units of an installation is made by engaging the plugs and sockets on the rear panel of the units with the respective sockets and plugs on the ends of the cables located in the back-plates on the racking system.

9. The back-plates are positioned on the mounting with the aid of special jigs listed in Table 2. If the back-plates were fitted without the use of jigs, serious misalignment would probably occur with resultant damage to the plugs and sockets of the equipment and the back-plates. The method of fitting a back-plate with the aid of a jig is described in para. 13.

10. Each back-plate carries two locating spigots which align the individual units to the associated back-plate. To improve mating, the multi-pole plugs and sockets will tolerate a small amount of misalignment. The coaxial sockets on the back-plates are designed to "float" for the same reason.

11. Each of the plugs and sockets on the rear panel are numbered in accordance with the circuit references, but the numbering of the plugs and sockets on the back-plates is related to the particular connector which it terminates. For example the plug PL2 on the rear panel of tuning unit Type 7180 will connect with the 28-way socket 8S on the back-plate (*fig. 1*); the plug is one termination of the 28-core connector, the other end being connected to 1S on the back-plate of the control unit Type 4243 (*fig. 2*).

12. The coding of the back-plates, individual units, and the associated cables is given in Table 1.

Method of fitting back-plates

13. The method of fitting a back-plate to the racking system is illustrated in Sect. 2, Chap. 10, *fig. 2*. The associated jig (*Table 2*) is laid in a horizontal position across the rear ends of the left and right vertical side-members so that the jig runs parallel with the rear U-shaped channel member. The "top" side of the jig is marked (e.g.) "Jig Ref. No. 10AG/54 for back-plate 10AG/442" (*Table 2*).

14. The back-plate is then lowered vertically at the back of the flanged ends of the side members until the locating spigots on the back-plate come to rest on the upper face of the rectangular jig.

15. With the back-plate and jig in this position the fixing screws of the back-plate which pass through the flanged ends of the side members, should be tightened until the back-plate is securely locked in position.

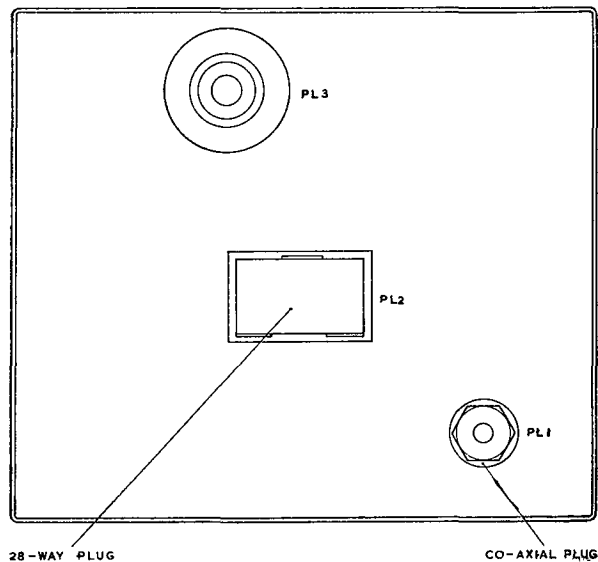
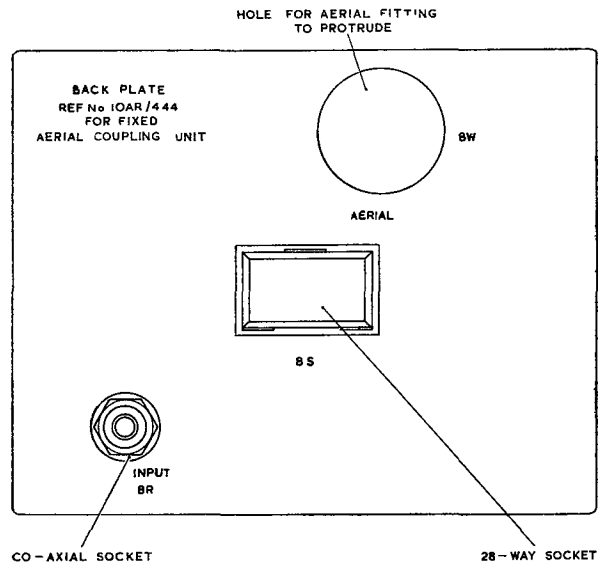

Fig. 1. Back-plate and connections to rear panel of aerial tuning unit

16. A further scrutiny should be made to ensure that the back-plate is properly aligned with the jig and the side members and the jig then finally removed.

INSTALLATION AND CABLING

17. There are variant installations in the one designation ARI.5874, the complement of movable equipment and cabling being different in each case. In the following description information is given on the main items of equipment and ancillaries which make up the installation for fixed wire aerial in the Beverley aircraft.

Fixed equipment

18. The items in Table 3 are listed as the fixed equipment required for the aircraft installation; the items are normally supplied to the aircraft contractor for installation at the works.

RESTRICTED

TABLE I
Connector and unit coding

	Unit	Code
Control unit Type 4243	1
Transmitter Type T.4188	2
Power and radio unit Type 4192	3
Receiver Type R.4187	4
Tuning unit (aerial) Type 7180	8
Control unit (remote) Type 4189	11
Junction box Type 4191	12
Voltage regulator	—

Connector code	Terminations			
A	1A	Control unit Type 4243	3A	Power and radio unit
B	1B	Control unit Type 4243	2B	Transmitter
C	1C	Control unit Type 4243	2C	Transmitter
D	2D	Transmitter	3D	Power and radio unit
E	2E	Transmitter	3E	Power and radio unit
F	3F	Power and radio unit	—	Intercom. equipment
J	3J	Power and radio unit		External transmitter interlock or transmitter Type T.4188 shorting plug
L	1L	Control unit Type 4243	4L	Receiver
M	4M	Receiver	—	Power supplies
N	3N	Power and radio unit	4N	Receiver
P	3P	Power and radio unit	—	Power supplies
R	1R	Control unit Type 4243	8R	Tuning unit (aerial) Type 7180
S	1S	Control unit Type 4243	8S	Tuning unit (aerial) Type 7180
W	8W	Tuning unit (aerial) Type 7180		To aircraft aerial
AD	4AD	Receiver	12AD	Junction box
AE	1AE	Control unit Type 4243	12AE	Junction box
AH	11AH	Control unit (remote)	12AH	Junction box

RESTRICTED

TABLE 2
Back-plate jigs

A.M. Stores Ref.	Back-plate	Unit
10AG/51	Jig, locating (Back-plate 10AR/438)	For power and radio unit Type 4192
10AG/52	Jig, locating (Back-plate 10AR/440)	For transmitter Type T.4188
10AG/53	Jig, locating (Back-plate 10AR/441)	For control unit Type 4243
10AG/54	Jig, locating (Back-plate 10AR/442)	For receiver Type R.4187
10AG/55	Jig, locating (Back-plate 5UC/6011)	For voltage regulator 5UC/6010
10AG/50	Jig, locating (Back-plate 10AR/444)	For tuning unit (aerial) Type 7180

TABLE 3
Fixed equipment

A.M. Stores Ref.	Description	Service	Dimensions (approx.)	
			Width	Height
10AD/444	Back-plate	For tuning unit (aerial) Type 7180	8 $\frac{3}{4}$ in.	7 in.
10AR/438	„ „	For power and radio unit	10 in.	5 in.
10AR/440	„ „	For transmitter T.4188	7 $\frac{1}{4}$ in.	3 in.
10AR/441	„ „	For control unit Type 4243	7 $\frac{1}{4}$ in.	7 in.
10AR/442	„ „	For receiver R.4187	7 $\frac{3}{4}$ in.	3 in.
5UC/6011	„ „	For voltage regulator (5UC/6010)	3 $\frac{3}{4}$ in.	5 in.
—	Terminal blocks	As shown in fig. 2	—	—
—	Switch label	Marked "ARI.5874 ON/OFF"	—	—
—	Switch label	Marked "TRANSMITTER OUTPUT HIGH/LOW"	—	—

19. An illustration of the complete installation for the Beverley aircraft is shown in fig. 2. (For information on suppressed aerial installations reference must be made to Sect. 2).

20. The interconnections of the installation are shown as they are connected to the back-plates

with the exception of those units which have direct entry plugs and sockets.

Removable equipment

21. The following items are listed as removable and include the main units of the installation.

TABLE 4
Removable equipment

A.M. Stores Ref.	Description	Service	Approx. weight
5UC/6010	Voltage regulator	Stabilized 19V supply to equipment	10.75 lb.
10L/16204	Control unit (remote) Type 4189	Remote control of transmitter/receiver and aerial equipment	2.65 lb.
10D/19066	Junction box Type 4191	Junction box between remote control unit and transmitter/receiver	1.4 lb.
10L/16207	Control unit Type 4243	Control unit and drive unit for transmitter	17.2 lb.
10D/19065	Transmitter Type T.4188	For use with suppressed or open wire aerial system	15.8 lb.
10D/19064	Receiver Type R.4187	For use with suppressed or open wire aerial system	26 lb.
10D/19067	Power and radio unit Type 4192	HT power supplies for transmitting circuits	34 lb.
10D/19238	Tuning unit (aerial) Type 7180	Aerial tuning unit	17 lb.

Note . . .

Control unit Type 4189 may be panel or console mounted; junction box Type 4191 is panel mounted (Sect. 1).

RESTRICTED

Connectors

22. The connectors described in Table 5 are for a fixed aerial installation in the Beverley aircraft. The information is provisional and Type numbers will be issued later.

23. Against the sleeve marking at each end of the connector is a reference in parenthesis; this is the code marking appearing on the back-plate against the socket or plug termination of the particular connectors (*Table 1*).

Equipment wires specification

24. The equipment wires referred to in the follow-

ing tables are listed in Defence Specification DEF-12 "Equipment Wires" (1st May, 1953) which includes the following note:—

"The American-British-Canadian Supply Classification (A.B.C.S.C.) 'Class' number for the wires specified in this DEF. Specification is 6145. This number and the item identification number shown in the tables make up the Catalogue number which should be quoted when reference is made to a particular wire, e.g. 6145-100168. Equipment wires shall be described by the Catalogue number followed by the name, type number, the conductor details and colour, e.g. 6145-100192, electrical equipment, Type 2S.7/0.0076 in Red".

TABLE 5
Connector schedule

The connectors in this schedule are those of the ARI.5874 in the Beverley aircraft

Item in Fig. 2	Identity sleeve marking Type and Ref. No.	Overall length of cable	Destination sleeve marking		Remarks
			End A	End B	
1	(10HA/153392)	4 ft. 0 in.	*Control unit Type 4243 (1A)	Power and radio unit (3A)	Pin to Pin Wire 6145-100179 to Pin No. 1, 4, 5, 6, 7, 8, 9, 10, 11, 12, 13, 15, 16, 17, 18, 19, 20 Wire 6145-100229 to Pin No. 2, 3, 14
2	(10HA/153402)	1 ft. 6 in.	*Power and radio unit (3D)	Trans T4188 (2D)	Pin to Pin Wire 6145-100168 to Pin No. 3, 4, 5, 8, 10, 13, 14, 19, 20, 28 Wire 6145-100179 to Pin No. 6, 7, 9, 11, 12, 16, 17, 25, 27, 15 Wire 6145-100229 to Pin No. 1, 2, 24 Wire 6145-100249 to Pin No. 22
3	(10HA/15341Z)	8 ft. 3 in.	Power and radio UNIT (3F)	Intercom.	INTERCOM. CONNECTIONS Pin Colour Sleeve 1 Red Tel Pos. 2 Blue Tel Nig & E 3 Green Mic 4 Yellow Mic 5 White Key 6 Black Power SW 7, 8 Earth (Screen) Sextovinsmall
4	EX/40F/ (10HA/15652)	—	TX Shorting plug (3J)	—	Pins 1 and 2 normally shorted with 22 S.W.G. tinned copper wire sleeved with P.V.C.
5	(10HA/15343Z)	†6 ft. 3 in.	*Recvr. R.4187 (4M)	Power supply	Power supply connections
6	(10HA/15344Z)	3 ft. 9 in.	*Recvr. R.4187 (4N)	Power and radio unit (3N)	Pin to Pin Wire 6145-100249 to Pin No. 1 Wire 6145-100179 to Pin No. 2, 3, 4.
7	(10HA/153452)	4 ft. 3 in.	*Power and radio unit (3P)	Power supply	

RESTRICTED

Table 5—contd.

Item in Fig. 2	Identity sleeve marking Type and Ref. No.	Overall length of cable	Destination sleeve marking		Remarks
			End A	End B	
8	(10HA/15346Z)	1 ft. 6 in.	Recvr. 4187 (4AD)	J. Box 5191 (12AD)	Pin to Letter Consecutive 25 Metvinsmall 2·5
9	(10HA/15347Z)	1 ft. 6 in.	Control unit 4243 (1AE)	J. Box 4191 (12AE)	Pin to Letter Consecutive 25 Metvinsmall 2·5
10	(10HA/15348Z)	4 ft. 6 in.	*Control unit 4443 (1S)	Aerial tuning unit (8S)	Pin to Pin 1-25 25 Metvinsmall 2·5
11	(10HA/15349Z)	4 ft. 0 in.	Control unit 4343 (1B)	Trans. T4188 (2B)	Uniradio 65
12	(10HA/15350Z)	4 ft. 0 in.	Control unit 4243 (1C)	Trans. T4188 (2C)	Uniradio 65
13	(10HA/15351Z)	2 ft. 0 in.	Power radio unit (3E)	Trans. T4188 (2E)	Uniradio 65
14	(10HA/15352Z)	2 ft. 6 in.	Control unit 4243 (1L)	Recvr. R4187 (4L)	Uniradio 65
15	(10HA/15353Z)	4 ft. 6 in.	*Control unit 4243 (1R)	A.T.U. (8R)	Uniradio 65
16	(10HA/15354Z)	3 ft. 6 in.	J. Box 4191 (12AH)	Control unit 4189 (11AH)	25 Metvinsmall Pin to Pin
17	(10HA/15355Z)	4 ft. 6 in.	*Voltage regulator	Supply	

Cables marked * are made up cables in polythene sleeving as there are no miniature cables in use which would meet the requirements. Cable lengths marked † include cut-back of 3 in. at End B.

RESTRICTED

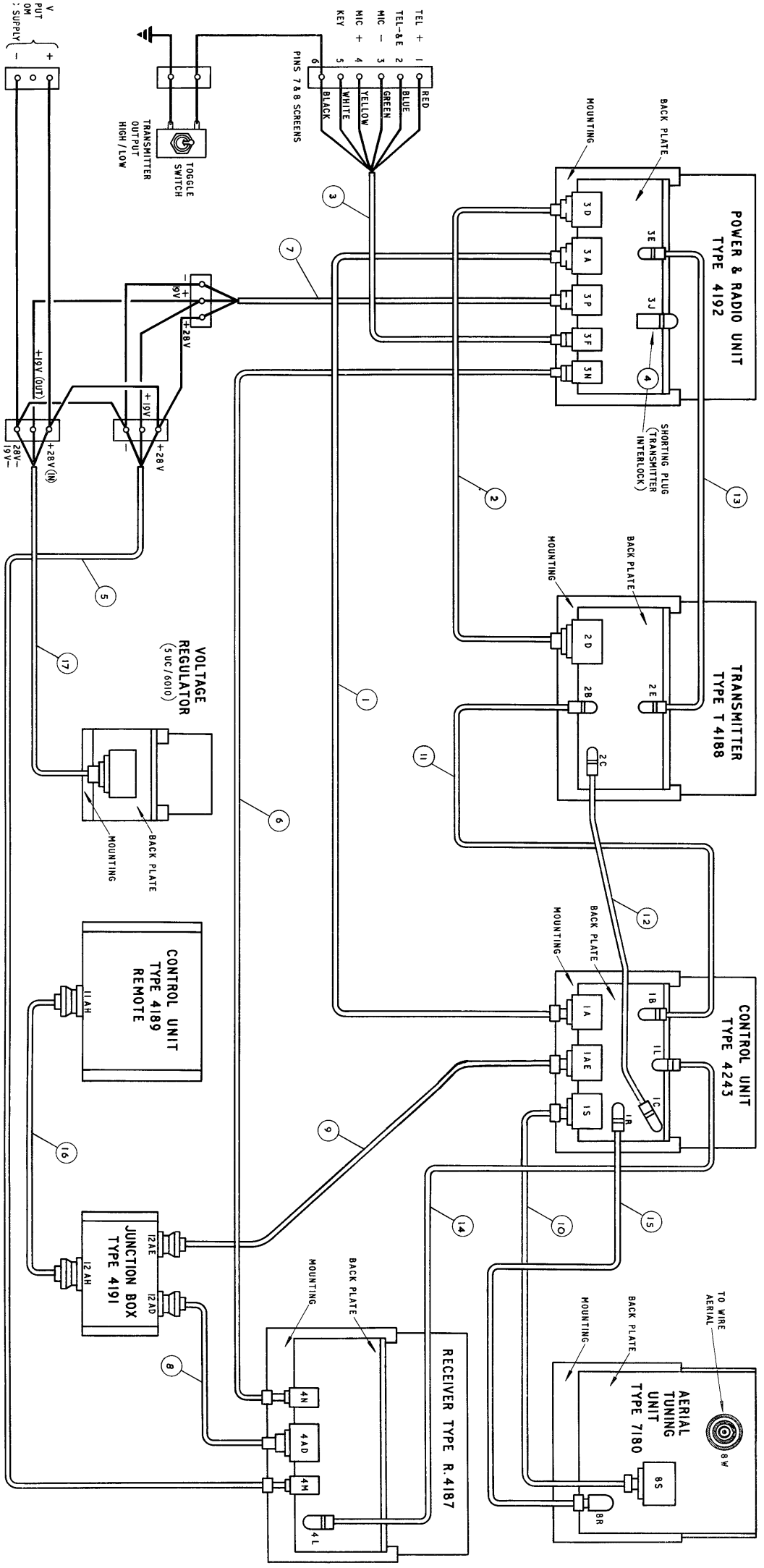

ARI.5874 with fixed wire aerial tuning unit.

RESTRICTED

Fig.2

(A.L.26, Oct. '55)

Chapter 4

SETTING UP AND OPERATION OF ARI.5874 WITH FIXED WIRE AERIAL SYSTEMS

LIST OF CONTENTS

	Para.		Para.
<i>Setting up instructions</i>		<i>Setting up the transmitter from the control unit Type 4243</i>	
<i>Introduction</i>	1	<i>by remote control</i>	25
<i>Preparation for setting up a frequency channel on the transmitter</i>		<i>Control unit Type 4243</i>	27
<i>Control unit Type 4243</i>	3	<i>Setting up to aircraft calibration</i>	30
<i>Drive unit front panel</i>	9	<i>Setting up when calibration is not available</i>	33
<i>Frequency band 2.8 to 7.0 Mc/s</i>	10	<i>Alternative method</i>	38
<i>Frequency band 7.0 to 18.1 Mc/s</i>	11	<i>Setting up the aerial tuning unit on "Manual"</i>	44
<i>Preparation for setting up a frequency channel on the receiver</i>	12	<i>Setting up the receiver</i>	
<i>Setting up the transmitter on a fixed wire aerial</i>		<i>To set up the receiver to a frequency channel already set up on the transmitter</i>	45
<i>Introduction</i>	17	<i>Operating instructions</i>	60
<i>Aerial tuning unit</i>	18	<i>Receiver</i>	62
<i>Transmitter</i>	20	<i>Transmitter</i>	63
<i>Aircraft power supplies</i>	21	<i>Aerial tuning unit</i>	64
		<i>Control unit (remote) Type 4189</i>	65
		<i>Emergency operation of aerial tuning unit</i>	66

LIST OF TABLES

	Table
<i>Calibration chart for tuning unit (aerial) Type 7180 when used in aircraft type</i>	1

APPENDIX

Calibration charts for various types of aircraft with fixed aeri- als (to be issued later).

RESTRICTED

SETTING UP INSTRUCTIONS

Introduction

1. The following instructions apply only to those installations of ARI.5874 fitted with fixed wire aerial systems.

2. It should be noted that after setting up the HF communications equipment and the aerial tuning unit, all power switching, channel selection and service switching is made at the control unit (remote) Type 4189. It is therefore necessary that the control unit should be readily accessible to the operator setting up the equipment or, alternatively, a second operator close to the control unit should be in some form of telephonic communication with the former.

PREPARATION FOR SETTING UP A FREQUENCY CHANNEL ON THE TRANSMITTER

Control unit Type 4243

3. Remove the control unit Type 4243 from the rack and take off the dust cover after releasing the fastener at the rear.

4. Open the crystal retainers covering the crystal sockets on each side of the chassis.

5. Insert crystal units Type ZDH of the selected (carrier) frequencies in the numbered sockets, using crystal extractor (located in receiver) if required. From the front, the sockets on the left-hand side 1A-1F (rear), 2A-2F (front) and on the right-hand side 1G-1M (rear) and 2G-2M (front).

6. Enter the crystal frequencies against the channel designation on the plate fitted to the front of the drive unit.

7. Close the crystal retainers and after replacing the dust cover, reinsert the control and drive unit in the racking.

8. Remove the cover from the potentiometers at the top of the front panel.

Drive unit front panel

9. Select the position of the 24 switches S2/1 and S2/2 according to the channel frequencies to be used. (Channels 1A-1M on left and 2A-2M on right.)

Frequency band 2.8 to 7.0 Mc/s

10. For the transmitter band 2.8 to 7.0 Mc/s the switch knobs should be "out" with the channel letter marking vertically inclined.

Frequency band 7.0 to 18.1 Mc/s

11. For band 7.0 to 18.1 Mc/s the switch knobs should be pushed in against the spring loading and turned 90 deg. until they locate firmly in that position. With the switch knobs "in" the channel letter markings will be horizontally inclined.

Note . . .

The tuning tool, clipped in the cover over the potentiometers may be used for turning the switch knobs as required.

PREPARATION FOR SETTING UP A FREQUENCY CHANNEL ON THE RECEIVER

12. Slide the receiver from the rack and remove the dust cover.

13. Open the door of the crystal oven. Place the crystal units Type ZDH for the required channels in the numbered sockets (using crystal extractors located in tuning potentiometer cover on receiver panel if required) and enter the channel frequencies on the tablet provided on the front panel. The crystal frequencies (f_x) have the following relationship to the channel frequency (f).

$$f = f_x \pm 2.15 \text{ Mc/s}; \quad \text{where } f \text{ and } f_x \text{ are in Mc/s,} \\ \text{and with the proviso that } f_x \text{ lies in the range 4.95 to 15.95 Mc/s.}$$

14. The crystal frequencies must be chosen in the following manner:—

	f	f_x
Band 1	1.8 to 5.2	$f + 2.15 \text{ Mc/s}$
Band 2	5.2 to 9.7	$f + 2.15 \text{ Mc/s}$
Band 3	9.7 to 18.1	$f - 2.15 \text{ Mc/s}$

15. When all the crystals required for use are in position, close the door of the crystal oven, replace the dust cover and return the receiver to the rack. Remove tuning potentiometer cover.

16. Select the required frequency ranges using the two groups of switches S9 and S10 as follows:—

Band 1	2.8 to 5.2 Mc/s	Switch lever UP
Band 2	5.2 to 9.7 Mc/s	Switch lever CENTRE
Band 3	9.7 to 18.1 Mc/s	Switch lever DOWN

Note . . .

The band numbers correspond to the three scales shown on the tuning drum dial.

SETTING UP THE TRANSMITTER ON A FIXED WIRE AERIAL

Introduction

17. The aircraft must be clear of the hangars for this operation.

Aerial tuning unit

18. Move the AUTO/MAN switch to the AUTO position.

19. Leave the TUNE switch "up" in the "operate" position.

Transmitter

20. Turn the AUTO/MAN switch 2S3 to AUTO. The meter switch 2S2 may be turned to any position.

Note . . .

If the proximity of the transmitter with relation to the control and drive unit is such that the meters on both units can be observed together, it is advantageous when tuning to leave the transmitter meter switch 2S2 in the "I_c" position. With these conditions the cathode-current of the P.A. stage can be continuously noted and some of the switching of the control and drive unit obviated.

RESTRICTED

until the FIRST maximum reading of I_g is attained. Adjust to maximum value.

- (6) Check I_e , if this is above 4.0 on meter, use key switch S4 as little as possible until an aerial output is obtained.

Note . . .

If the transmitter unit is visible, the instructions in sub-para. (1) can be omitted, the dial on the transmitter being turned by use of the potentiometer knob to approximately the correct frequency.

- (7) Choose the settings from Table 1 (Appendix) corresponding to the frequency nearest to that to which it is required to set up.
- (8) Set these figures on the aerial tuning unit by adjustment of the appropriate controls (INPUT, SERIES and OUTPUT) on control unit Type 4243 ((sub-para. 16) and Note 2).
- (9) Depress key 1S4 to the TUNE position and adjust the OUTPUT control until the AE indication is a maximum.
- (10) Check the value of I_c which should be approximately 3.5 in the TUNE position. If this value is obtained, check that I_c does not exceed 4.25 approx. in the TEST position.
- (11) Alternate the adjustment of INPUT and OUTPUT until the maximum value of AE consistent with a loading of 4.25 approx. on TEST is obtained.
- (12) If I_c is too great it can normally be reduced by reducing the OUTPUT dial reading, i.e. by (counter-clockwise) movement of the potentiometer.
- (13) If it is not possible to load the transmitter fully, select the next highest lamp number. If the transmitter is overloaded select the next lowest lamp number.
- (14) Repeat for all the remaining channels. After adjustment of all channels, make out a form similar to Table 1 for the particular aircraft, noting the aerial tuning unit settings for the actual frequencies used. These figures can later be used for manual setting up of the aerial tuning unit in the event of failure of the channel resetting mechanism and for subsequent resetting of the aerial tuning unit on these frequencies.
- (15) Eventually a second calibration chart will be obtained on this form and the guide calibration chart for the particular type of aircraft (Table 1—Appendix) will be superseded by the one directly associated with the equipment.
- (16) The control unit Type 4243 potentiometers can be set (sub-para. (8)) on STD/BY in the workshop using a "slave" aerial tuning unit or alternatively the aerial tuning unit from the particular aircraft (see Note 2).

- (17) It is recommended that pre-adjustment conforming with the above procedure is regarded as the normal operation method since it presents a considerable saving in time.

SETTING UP WHEN CALIBRATION IS NOT AVAILABLE

33. Set up the equipment by repeating the instructions given in para. 3 to 29.

- (1) Set up the aerial tuning unit controls as follows.
- (2) Turn the INPUT potentiometer knob counter-clockwise until the stop is reached (POT. 3, POT. 4).
- (3) Turn the SERIES potentiometer knob counter-clockwise until lamp No. 1 glows (POT. 5, POT. 6).
- (4) Turn the OUTPUT potentiometer knob counter-clockwise until the stop is reached (POT. 7, POT. 8).

Note . . .

When adjusting the SERIES control until one of the COUPLING lamps indicate (LP5), it will be found that these glow over approximately one turn of the potentiometer knob. The knob should be set in the approximate mid-position of the "glow arc".

34. Now alter the SERIES potentiometer knob until the capacitor number is in agreement with that given for the nearest frequency selected from a Table 1 compiled for an aircraft with a similar aerial system.

35. Now read the cathode current I_c and with key 1S4 on TUNE, turn the INPUT potentiometer knob clockwise until the first "dip" is noted in I_c (para. 38). Refer to AE and turn the OUTPUT knob clockwise until a reading is obtained.

36. Readjust the INPUT to "dip" on I_c and repeat input to output until the maximum value of AE is obtained consistent with the loading limits of para. 32 (10) and (11).

37. If it is not possible to load fully, select the next highest capacitor number; if overloaded, i.e. I_c reading high, select the next lower capacitor number.

Alternative method

38. It is not always possible to find the "dip" in I_c at some lower frequencies. In this case the following method can be tried.

39. Select the SERIES capacitor as before. Then turn the INPUT potentiometer approximately five turns in a clockwise direction. Turn the OUTPUT potentiometer carefully clockwise at the same time reading AE, until some output is obtained.

40. Adjust INPUT and OUTPUT until correctly loaded or repeat using adjacent capacitors as before.

RESTRICTED

41. If information concerning the correct capacitor is not available the following method of setting up should be used:—

- (1) Select capacitor No. 1 and carry out the instructions given under "Alternative Method". If output is indicated, try capacitor No. 2 and compare results, then continue in order of capacitor numbers until optimum results are obtained.
- (2) If similar outputs are obtained on two successive capacitor selections, use that which gives the better cathode current I_c . It is normal for this to be the lower capacitor number of the two.

42. As an alternative to the method given in para. 38, the method in para. 34 to 36 can be used commencing with capacitor No. 1.

43. When the tuning has been accomplished it would be advantageous to make out a "TABLE 1" for the aircraft type and keep it with this Air Publication—pending the issue of an official Appendix.

Note 1.

The meter reading at AE is set so that on a low impedance aerial (i.e. voltage low, current high) the meter reads the RF aerial current in amperes approx. On a high impedance aerial (voltage high, current low) the meter reads volts times 1,000 approx. The relative voltage/current sensitivity can be adjusted by means of potential dividers 8VR2 and 8VR1 on the aerial tuning unit. The best settings of these can be found by experiment to give the maximum possible indication on the meter over the frequency range of the aerial, consistent with not exceeding full-scale deflection (generally at the LF end of the range). These settings can then be set in workshops for a particular aircraft/aerial installation.

Note 2.

As stated in para. 32 (16), the control unit Type 4243 and the aerial tuning units can be set up in the workshop on the test rig. It will be found that there is very little difference between the characteristics of the aerial tuning units for the same dial calibration. Therefore, if an aerial tuning unit is set to a recorded calibration, taken perhaps on another aerial tuning unit, the unit should not be far off resonance when installed in the aircraft. Nevertheless, the aerial tuning unit should always be finally trimmed.

SETTING UP THE AERIAL TUNING UNIT ON "MANUAL"

44. When initially calibrating the aerial tuning unit it may be found easier to do this manually instead of by the potentiometers on control unit Type 4243. However, it must be noted that it will be necessary to read cathode current on the control unit whilst tuning and for this reason the manual method may be inconvenient if the meter cannot be seen from the aerial tuning unit position.

- (1) Switch to TRANSMIT and CW1 on the remote control unit.
- (2) Switch the aerial tuning unit S1 to MANUAL.
- (3) If the aerial tuning unit is to be tuned when calibration is not available, rotate the three controls INPUT, SERIES and OUTPUT fully counter-clockwise. If Table 1 is available (*Appendix*), set to the calibrations for the frequency nearest to that required.

Note . . .

A pencil or similar shaped object will be useful when rotating the manual controls.

- (4) Carry out the appropriate tuning drills as previously described, using the switch S2 on the aerial tuning unit in the TUNE position and the meter M1.
- (5) Note that S2 in the TUNE position effectively keys the transmitter on tuning power and therefore the final loading check of I_c should be carried out with the switch S5 on the control unit Type 4243 in the OPERATE position. Meter M1 will only read with switch S1 in the MANUAL position. The reading being transferred to the control unit 4243 in the AUTO position.
- (6) When the required settings of the aerial tuning unit have been found, the unit will have to be set up again to these settings from the control unit Type 4243 on the appropriate channels with the aerial tuning unit switched to AUTO.

SETTING UP THE RECEIVER

To set up the receiver to a frequency channel already set up on the transmitter

45. First check that the preparation for setting up has been carried out in accordance with para. 12 to 16.

46. At the remote control unit move the service switch to R/T and the power switch to STD/BY. The rotary transformer in the receiver will run.

47. Set the TUNE/NORMAL switch on the receiver front panel to TUNE. The dial lamp should light.

48. Remove the cover from the potentiometers POT.1 and POT.2, and the two groups of switches S9 and S10.

49. Rotate the RF GAIN control on the remote control unit to the maximum position.

50. Move the FINE TUNING control on the remote control unit to its centre zero position.

51. Using the tuning tool, turn all the required potentiometer control knobs to the fully counter-clockwise position.

RESTRICTED

POT. 2 (with white spot) together with S10 (white knobs) covers channels 1A-1M

POT. 1 (with black spot) together with S9 (black knobs) covers channels 2A-2M

52. Select the required frequency ranges using the two groups of switches S9 and S10 as in para. 16.

53. If the external ambient temperature is very low allow a full 10 minutes for the crystal oven to gain temperature.

54. Select the required channel on the remote control unit.

55. Rotate the receiver tuning control TUNE until the required frequency is indicated on the scale against the cursor. Then, using the phones, finally adjust the TUNE control until the receiver input noise reaches the maximum.

56. Leave the TUNE control in this position and turn the appropriate potentiometer control knob clockwise until the TUNING lamp goes out. This completes the tuning of the particular channel.

57. Check that the correct channel frequency has been entered on the tablet on the front panel.

58. Repeat for other frequencies as required.

59. Switch the TUNE/NORMAL switch to NORMAL and select each channel in turn to check that tuning is complete.

OPERATING INSTRUCTIONS

60. No attempt should be made to operate the equipment until it has been properly set up.

61. Make the following checks on the equipment before switching on at the remote control unit.

Receiver

62. Check that the TUNE/NORMAL switch is in the NORMAL position (if the potentiometer cover is properly fastened in position a projection from the cover ensures that the switch is in the NORMAL position).

Transmitter

63. Check that the AUTO/MAN switch is in the AUTO position.

Aerial tuning unit

64. Check that the AUTO/MAN switch is in the AUTO position.

Control unit (remote) Type 4189

65. After ensuring that the local switches on the equipment are in the position described above, the equipment may be operated from the remote control unit.

(1) Turn the power switch to S/BY.

(2) Select the channel to be used on the CHANNEL NUMBER and CHANNEL LETTER switches.

(3) The TUNE lamp will go out when the equipment is tuned.

(4) Select the position required on the service switch (R/T, MCW, CW1 or INTERTUNE).

Note . . .

CW2 is position of greatest selectivity. The equipment cannot be operated until the TUNE lamp goes out.

(5) Adjust the final receiver tuning by means of the FINE TUNING control.

(6) Wait 30 seconds and then switch to TX.

Note . . .

If the transmitter is required for "instant readiness" the power switch should be left on TRANSMIT.

(7) The channel letter and number aperture illumination is controlled by the DIM potentiometer.

(8) The gain of the receiver is varied by the rotation of the RF GAIN control.

(9) When receiving on CW, the beat note can be varied by adjustment of the FINE TUNING control.

Emergency operation of aerial tuning unit

66. In the event of failure of the channel selector mechanism on the aerial tuning unit, the following procedure can be adopted if the aerial tuning settings are available.

(1) Select the required channel and wait until the TUNE lamp goes out.

(2) At the remote control unit switch to TRANSMIT and CW1.

(3) On the aerial tuning unit place the AUTO/MAN switch to the MANUAL position. (If the TUNE lamp remains alight it indicates that the TUNE line in the aerial tuning unit is earthed due to a fault. In this event no further action can be taken.)

(4) Set the three aerial tuning unit controls to the calibrations for the channel required.

(5) Press the OP/TUNE switch and tune the OUTPUT control for a maximum reading in the adjacent meter.

(6) Operate the equipment on this channel from the remote control unit in the normal way, bearing in mind that aerial output indication will not be available in the meter M1.

(7) When it is required to change to another channel, the aerial tuning unit must be reset manually as before.

(8) If no aerial tuning unit settings are available the full aerial tuning procedure could be carried out as described in para. 44.

RESTRICTED

Appendix I

CALIBRATION CHART FOR TUNING UNIT (AERIAL) TYPE 7180 WHEN USED IN CANBERRA AIRCRAFT

(Aircraft fitted with polythene covered, copper clad, steel aerial wire.)

Frequency kc/s	Input	Coupling	Output
3,000	60	2	210
4,000	40	4	80
5,000	340	6	330
6,000	340	6	60
7,000	30	5	30
8,000	30	3	110
9,000	70	2	100
10,000	80	2	70
11,000	30	3	40
12,000	280	2	40
13,000	70	4	20
14,000	20	4	30
15,000	30	3	60
16,000	40	3	30
17,000	330	3	50
18,000	160	3	40

The "Coupling" column is the value of the series element as indicated by lamp number.

Select the calibrated frequency nearest to that on which it is required to set up.

If it is not possible to load the transmitter fully, select the next highest lamp number.

If the transmitter is overloaded select the next lowest lamp number.

Chapter I

INTRODUCTION TO ANTI-STATIC AERIAL EQUIPMENT

LIST OF CONTENTS

	Para.		Para.
Introduction	1	<i>Dip, tension and span</i>	22
		<i>Slack</i>	25
General description		<i>Stretch</i>	29
<i>Aerial masts</i>	3	<i>Temperature effects</i>	30
<i>Tension units</i>	6	<i>Effect of change of aerial loading caused by ice, etc.</i> ...	32
<i>Strain insulators</i>	10	<i>Summary of mechanical considerations</i>	34
<i>Insulated aerial wire</i>	11	<i>Method of tensioning</i>	35
<i>Construction and strength of aerial wire</i>	12	<i>Additional data on dip, slack and stretch of insulated aerial wire</i>	39
<i>Methods of tensioning</i>	20	<i>Detailed information</i>	40

LIST OF TABLES

	Table
<i>Main components of aircraft anti-static aerial systems</i> ...	1
<i>Information on dip, slack and stretch of insulated aerial wire</i>	2

Introduction

1. Modern wire aerial systems on aircraft are designed to improve the overall efficiency of aircraft radio communications by the introduction of specially insulated masts, terminations and aerial wire. The equipment described in this Section provides the following improvements in aircraft aerial efficiency.

- (1) Elimination of aerial leakage losses under all weather conditions for long operational periods.
- (2) Efficient aerial tensioning to prevent excessive strain on the aerial and its anchorage.

- (3) Compliance with airworthiness regulations for an aerial weak link.

Note . . .

The efficiency of the system is also improved by the controlled discharge of static collected by the airframe during flight, thereby reducing corona to a minimum. This is brought about by use of wick dischargers which are not described in this publication.

2. Different types of aircraft create the necessity for variations in design of aerial masts, terminations and junctions. These are provisioned as listed in Table 1.

TABLE I
Main components of aircraft anti-static aerial systems

Item	A.M. Ref. No.	Aircraft Type	Manufacturer's Part No.
Mast, Aerial Type 67	10B/16893	Valetta	C.E.3002, Type 300/2
Mast, Aerial Type 68	10B/16894	Comet	C.E.3668
Mast, Aerial Type 69	10B/16895	Canberra	C.E.5017
Tension unit, aerial, forward	10B/16899	Comet	C.E.4144
Tension unit, aerial, aft	10B/16898	Comet	C.E.4145
Tension unit, aerial, aft	10B/16897	Canberra and Hastings	C.E.4063, Type SJWC
Insulator Type 843 (strain insulator)	10B/16891	Valetta	C.E.3514, Type CFW
Insulator Type 844 (strain insulator)	10B/16892	Comet	C.E.3985
Aerial WS.25/U (insulated aerial wire)	5E/3756	All types	C.E.5048

RESTRICTED

GENERAL DESCRIPTION

Aerial masts

3. There are three types of mast at present in use (*Table 1*). Each type is of robust design suitable for supporting insulated aerials for a HF transmitter-receiver system on large or high-speed aircraft. The masts are constructed from glass-fibre laminates coated with neoprene for protection against rain and ice erosion.

4. Each type of mast has a polythene head with lead-in component insulation. The masts may be fitted to pressurized or unpressurized aircraft. The overall dimensions of the masts vary according to the type of aircraft to which they are to be fitted.

5. The insulated aerial wire is terminated in a spring-loaded split chuck fitted in the head of the aerial mast and secured by a stainless-steel pin to a lead-in assembly. The head cap of the mast is in moulded black polythene and the lead-in assembly consists of a nickel-plated brass conductor to which is fitted the chuck unit. The head-cap moulding is formed to provide complete insulation of the lead-in and chuck unit. The conductor of the lead-in assembly and its insulation passes through a sealing grommet in the base-plate of the mast and extends below the base (inside the airframe) for connection to the transmitter-receiver equipment.

Tension units

6. Aerial tension units are designed to introduce spring tension into the aerial run which can take up variations in aerial span caused by airframe distortion. This prevents excessive strain on the aerial and its anchorages.

7. To meet practical and safety requirements the following features are embodied:—

- (1) A weak link in accordance with airworthiness requirements.
- (2) Visual indication of aerial tension.
- (3) A locking device for simplification of installation.
- (4) Adjustable overall length which aids installation and compensates for small physical variations in aerial length.
- (5) The inclusion of a line insulator.

8. Each tensioning unit (*Table 1*) can be fitted with a weak link in the form of a one-sixteenth-inch diameter copper rivet. The location of the weak link varies with the type of tensioning unit. Where a weak link is not required a steel pin of the same size can be fitted.

Note . . .

Tests have proved that the breaking tension for aerials without weak links exceeds 500 lb.

9. Tension units are equipped with a chuck at the aerial end similar to that fitted to the aerial mast. This will grip the aerial wire without bending or tendency to fracture. The other end of the

unit holds the tensioning device consisting of a spring mechanism with an adjustable tail rod held in a plunger. When a load is applied to the tension unit, the spring is compressed and the tension can be measured from the amount of extension of the tail rod beyond the end of the tension unit.

Strain insulators

10. Strain insulators such as insulator Types 843 and 844 are used to terminate aerials where it is not required to use a tension unit. Insulators Type 843 and 844 are fitted with a chuck at one end to which is connected the aerial wire and a fork at the other end for connection to the airframe or special aerial termination.

Insulated aerial wire

11. Since the aerial is directly coupled to the receiving equipment, the first step in providing an anti-static system is to protect the aerial wire itself. This is effected by using polythene-covered wire which gives a very large reduction in impact static. That a special type of wire is required will be obvious from the stresses which occur on any object external to the airframe of high-speed aircraft. The type of wire used and the method of tensioning and terminating is discussed in the following paragraphs.

Construction and strength of aerial wire

12. The stress in an aerial tolerably free from sag is very high and the difference between the length of the wire and the span between its terminations is negligible. It is, therefore, necessary to use a wire of very high tensile strength to meet the first condition; secondly, the wire must be of extremely low ductility if the aerial is not going to sag badly because of stretching.

13. It was at one time considered desirable for the wire to be multi-stranded because of its greater resistance to fracture. In modern aerial installations the aerial is, in effect, a "spring" wire in considerable stress and if properly terminated, e.g. in a chuck, there is no need to bend or solder the wire and, therefore, no tendency to fracture.

14. It is possible for a chuck to grip a cable of not more than seven-strands, but the conditions may be critical since the cable deforms under the load of the jaws. Seven-stranded wire is not very flexible and has little advantage on this score over a single-strand conductor. Multi-stranded cables cannot be held in chucks and must be terminated in a bend or twisted joint which of course, demands a wire of high ductility.

15. Pre-stressed stainless steel cables with swaged terminations would probably be satisfactory for the purpose but they would need special terminating equipment and would present problems in coating to reduce RF resistance.

16. The only wire which meets the mechanical requirements is of high tensile steel, preference being given to a single conductor. The RF resistance of steel wire however, has been found to be great enough to materially reduce the radiated

RESTRICTED

power from a transmitter. Tests show that by changing from phosphor-bronze to stainless-steel wire the radiated power may be reduced to one-third and the RF resistance of the aerial increased over 40 times.

17. To overcome the difficulties presented by ordinary stainless-steel wire, a steel-cored wire of diameter 0.0508 in. is used with a coating of 0.0005 in. of copper. Owing to skin effect the RF resistance of this wire is practically equal to that of pure copper. It has a tensile strength of between 450 and 520 lb., the DC resistance is 11.1 ohms per 1,000 ft. and the weight is 1.7 lb. per 100 foot.

18. The wire is polythene insulated with a dielectric strength of 25 kV and conforms to an American specification MIL-E-6370A; it is identified by the designation WS.25/U printed on the insulation at 12 in. intervals. The dark brown pigmented polythene covering gives the wire an overall diameter of 0.183 in.

19. The description of the aerial wire for Service purposes follows:—

5E/3756 Aerial WS.25-U Polythene-covered wire single strand copper-covered steel 0.0508 in. Manufacturers Part No. 5048. (For all types of aircraft.)

Methods of tensioning

20. Before a decision can be made on the tensioning conditions for a particular aerial installation, it is useful to know the expression relating the various factors such as dip, span, weight and tension. The following information is concerned with static conditions only, since insufficient data is available to assess dynamic loads. The figures quoted assume the use of the selected aerial wire WS-25/U.

21. The expression given relates strictly to reasonably taut horizontal wires, but the same general principles apply when the two end supports of the aerial are not at the same level. The dip is then measured vertically half-way between the two supports.

Dip, tension and span

22. The following relationship holds:—

$$\frac{\text{Dip}}{\text{Span}} = \frac{\text{Weight}}{8 \times \text{tension}}$$

23. A convenient working rule is to tension to 1 lb. per foot span, i.e. to keep the ratio dip/span constant. With aerial wire which weighs 1.7 lb. per 100 ft. this gives a dip of one inch per 40 ft. span (*Table 2*).

24. The suggested rule is by no means critical but may be used as a guide. There would appear to be some advantage in increasing the tension, the limiting value being set by the necessity to

allow an adequate margin of safety under conditions of icing, airframe distortion on landing, etc. One question which arises here is how far can slack in the aerial (defined for this purpose as the difference between the length of wire and the span) be used to take up any distortion. It will be seen from the expressions which follow (*para. 25*) that the length of slack in all practical cases is almost negligible.

Slack

25. The difference between the length and span of an aerial is defined as:—

$$\text{Slack} = \frac{\text{Dip} \times \text{Weight}}{3 \times \text{Tension}}$$

26. Bearing in mind that the normal dip is small (of the order of one inch) and that the ratio of weight to tension is also small (about $\frac{1}{60}$), it will be seen that the slack is virtually negligible; for a 60 ft. aerial tensioned to 60 lb. it is less than one-hundredth of an inch.

27. The expression given in *para. 25* was chosen because it gives a clear indication of the relative smallness of the slack, but for some calculation purposes it is more convenient to use

$$\text{Slack} = \frac{\text{Span}}{2R^2}$$

Where $R = \frac{\text{tension}}{\text{weight}}$ here slack is in inches and the span in feet.

28. For example, since we know that the slack is negligible when the aerial is tensioned, we may use this to find out how much slack is taken up when pulling up a 60 ft. aerial from a tension of 5 lb. to 60 lb.; this works out at about 1.25 in. Elastic expansion of the wire under load, which is discussed next (*para. 29*) also contributes to the movement of the aft end of the aerial as it is tensioned and in fact becomes the predominating cause after the initial slack has been taken up.

Stretch

29. It has already been stated that the wire in a taut aerial about 50 ft. long is under considerable stress and this necessitates the use of a high tensile steel. The selected wire WS.25-U has an ultimate tensile strength of 170 tons per square inch, the stress being about 800 lb./sq. in. per lb. tension. A 50 ft. aerial tensioned to 50 lb. would be stretched about five-eighths inch beyond its unstressed condition (0.025 in./lb./100 ft.).

Temperature effects

30. The tension in the aerial will be affected by the temperature but it is difficult to arrive at quantitative values, since the change in tension will depend on the distortion of the airframe.

31. If the aerial is constrained to a fixed length, the change in tension per degree centigrade drop in temperature is given by the product of the area, Young's modulus and the temperature coefficient

RESTRICTED

of expansion of the wire. This works out at just over 0.5 lb. It is reasonable to assume that, in general, the distance between the suspension points on the airframe will expand and contract with temperature at about the same rate as the cable, so that temperature effects will not be so large as this figure would suggest.

Effect of change of aerial loading caused by ice, etc.

32. The change in tension in an aerial for a very considerable change in its effective weight (caused, for example, by icing or cross winds) is fortunately small.

33. For a given span the slack is proportional to the square of the dip so that for the case of a 60 ft. aerial tensioned to 60 lb., doubling the original dip of 1.5 inch (*Table 2*) would need an expansion of about 0.025 in. or an increase in tension of less than 2 lb.

Summary of mechanical considerations

34. The causes and effect of the mechanical changes in the aerial described in the preceding paragraphs can be summarized as follows:—

(1) If the airframe distorts, the aerial wire itself is stretched by the amount of distortion and there is virtually no slack to take up which would relieve this stress.

(2) Once an aerial is tensioned, a formation of ice, unless very severe, does not appreciably alter the tension.

(3) A wire of high tensile strength will withstand very considerable airframe distortion before failing. For example, a 50 ft. span of WS-25/U wire initially tensioned to 50 lb. would stretch 5 in. before reaching its breaking load.

Method of tensioning

35. It is common practice to provide a spring unit in an aerial to take up airframe distortion. It may be asked how far such tension units are necessary

in view of the added weight and the conclusions just reached on the elastic stretch of available aerial wires. The answer must depend partly on the anticipated distortion of the airframe but mostly on whether the distortion can be more economically catered for by a spring than by reinforcing the end supports to permit the full stretch of the wire to be used.

36. It is desirable, and in fact a Service requirement, that a weak link should be provided in the aft end of open wire aerials to ensure that, if failure does occur, it shall not be at the forward end thus leaving the wire free to wrap itself around control surfaces. The normal weak link is designed to fail at 170 lb. which allows approximately 2 inches extension before the weak link shears.

37. A choice of breaking loads can be had by changing the material or diameter of the weak link. However, the higher the failing load, the greater is the energy stored in the wire if it is released. We must, therefore, take into account the damage which may be done during flight by recoiling wire with a high breaking load.

38. By using a tension unit, a greater degree of distortion can be handled for a given amount of stored energy; in addition, the total energy is divided between the wire and the tension unit spring. A well-designed tension unit can also simplify and speed-up the process of installation and dismantling. It also provides in itself a spring-balance on which the aerial tension can be measured simply and quickly.

Additional data on dip, slack and stretch of insulated aerial wire

39. From measurements made on a sample of wire it was found that the weight is 1.7 lb./100 ft. and the stretch under tension 0.025 in./lb. per 100 ft. From this data the following table was compiled; the information should be used as a guide only.

TABLE 2
Information on dip, slack and stretch on various lengths of insulated aerial wire WR.25/U

Length of Aerial (feet)	Dip in inches			Slack in inches			Stretch in inches			Wt. (lb.)
	At 5 lb.	At 50 lb.	At 1 lb./ft.	At 5 lb.	At 50 lb.	At 1 lb./ft.	At 5 lb.	At 50 lb.	At 1 lb./ft.	
20	2	0.2	0.5	0.05	—	—	0.03	0.25	0.1	0.34
30	4.5	0.45	0.75	0.15	—	—	0.04	0.38	0.22	0.51
40	8	0.8	1.0	0.37	—	—	0.05	0.5	0.4	0.68
50	12.5	1.25	1.25	0.72	—	—	0.06	0.63	0.63	0.85
60	18	1.8	1.5	1.25	0.01	0.01	0.08	0.75	0.9	1.02
70	24.5	2.45	1.75	1.97	0.02	0.01	0.09	0.88	1.22	1.19
80	32	3.2	2	2.96	0.03	0.01	0.1	1.0	1.6	1.36

Detailed information

40. Detailed information on the various items such as aerial masts, tension units and insulators

will appear in other Chapters on this Section. Reference should be made to the List of Contents in the preliminaries of this Volume.

RESTRICTED

Chapter 2

MAST, AERIAL, TYPE 69

LIST OF CONTENTS

	Para.		Para.
<i>Introduction</i>	1	<i>Method of aerial termination</i>	12
<i>General description</i>		<i>Modification to terminal shroud</i>	13
<i>Mast shell</i>	5	<i>General maintenance</i>	16
<i>Head cap and lead-in assembly</i>	7	<i>Insulation breakdown</i>	17
<i>Chuck unit for insulated aerial wire</i>	9	<i>Aerial and mast inspection</i>	19
<i>Installation</i>		<i>Repairs</i>	20
<i>Aerial mast to airframe</i>	10	<i>Neoprene repair</i>	22
		<i>Spare parts</i>	25

LIST OF ILLUSTRATIONS

	Fig.
<i>Mast, aerial Type 69—mast shell</i>	1
<i>Mast, aerial Type 69—Head cap moulding</i>	2

Introduction

1. Aerial Mast Type 69 (10B/16895) is designed for use with fixed aerial applications of ARI.5874 on aircraft to which wire aerials may be fitted. The mast may be fitted to pressurized or unpressurized aircraft.

2. A sectional drawing of the aerial mast Type 69 is given in fig. 1; although the mast cannot be dismantled beyond the removal of aerial termination fittings, the mast shell and head cap have been treated as two separate components. The head cap is illustrated in fig. 2.

3. The complete mast has an overall height of seven inches; it is streamlined and destruction tests have shown the following breaking moments:—

- | | |
|-----------------------------|--------------------|
| (1) Along fore and aft axis | ... 10,000 lb.-in. |
| (2) Side load | ... 4,500 lb.-in. |

4. Electrical tests have been made with the mast mounted on an earthed metal plate simulating the airframe and having a 2 in. diameter hole through which the transmitter-receiver terminal boss projected. Tests were made at 100 kc/s and 1 Mc/s and in each case the break-down voltage was found to exceed 20 kilovolts.

GENERAL DESCRIPTION

Mast shell

5. The mast shell (fig. 1) is a resin-bonded, fibre-glass laminate. A reinforcing block is fitted within the mast head and a tube, extending between the head and base plate, supports the conductor rod.

The base plate is bonded to the mast shell and flared to form the flange attachment to the aircraft skin. The flange and base plate are drilled and fitted with bushes to accommodate 2BA bolts (fig. 1).

6. Protection against rain, hail and ice erosion is afforded by coating the shell with neoprene to specification DTD.856A. Twenty coats of neoprene are applied to provide a coating 0.02 in. thick.

Head cap and lead-in assembly

7. The head cap and lead-in assembly consists of the head-cap moulding (fig. 2) and nickel-plated brass lead-in components. The head cap is moulded in black polythene and, as indicated in the drawing, completely insulates the lead-in components consisting of the horizontal lead-in fork and the vertical conductor. The vertical conductor extends 4 in. below the base plate to make the aerial tuning unit termination.

8. A terminal shroud over the extended end of the conductor serves to clamp the sealing ring which was introduced in the modification described in para. 13. The shroud is fitted with a washer and secured by a $\frac{1}{4}$ in. BSF nut and locknut. The aerial tuning unit termination is secured with two $\frac{1}{4}$ in. BSF nuts.

Chuck unit for insulated aerial wire

9. To connect the insulated aerial wire to the mast lead-in, a chuck unit is used; this is shown in fig. 2 which illustrates how the chuck unit assembly

RESTRICTED

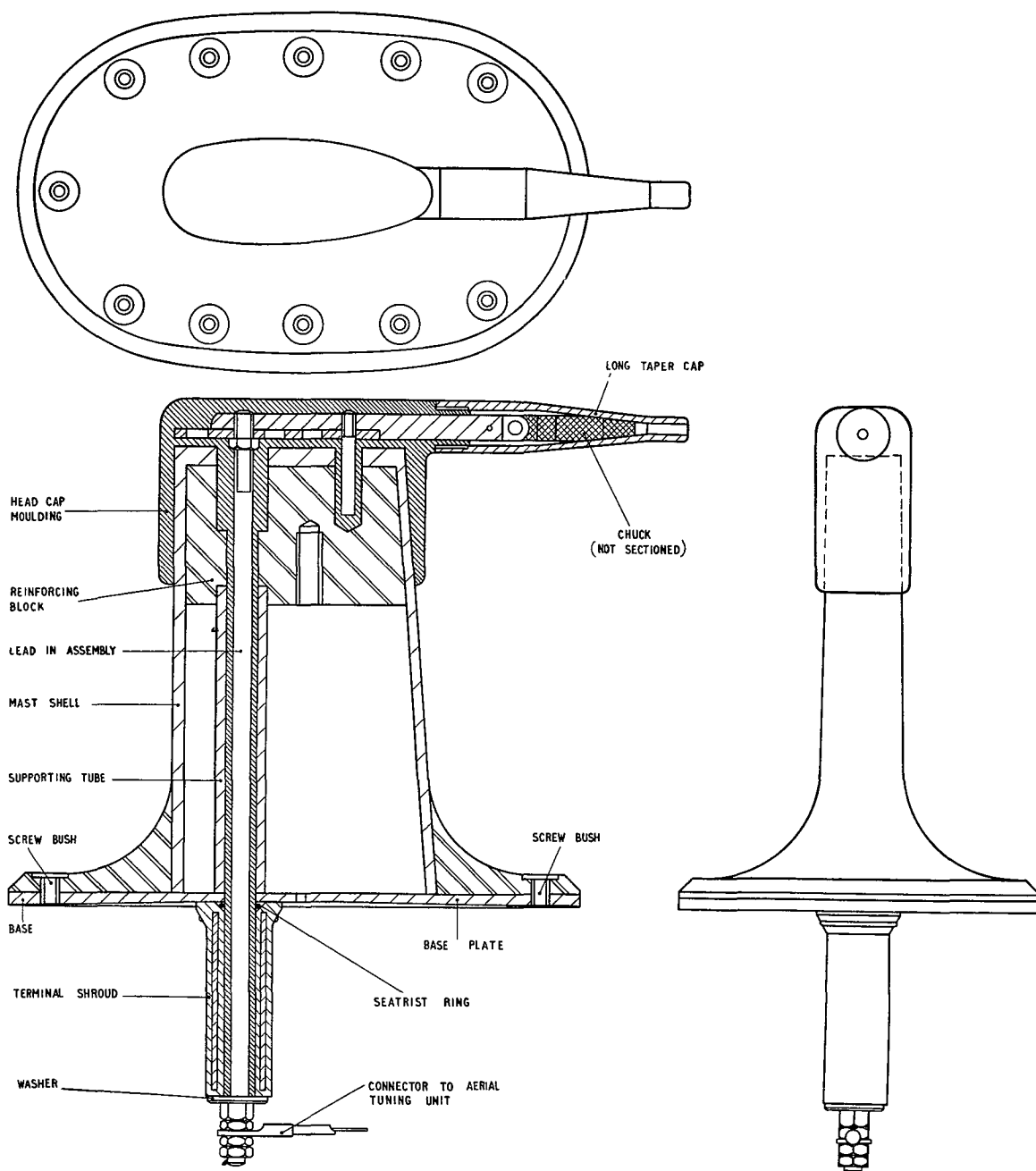

Fig. 1. Mast, aerial Type 69—mast shell

can be connected to the lead-in fork. The chuck unit consists of a spring-loaded split chuck within a knurled housing, the whole being retained by a plug end which is the male connection to the lead-in forked end. The chuck unit is assembled to the fork by a shackle pin secured by a split pin (*para. 25*).

INSTALLATION

Aerial mast to airframe

10. Aircraft skin panels upon which aerial masts are mounted must be reinforced as necessary, with a stiffening plate or other structure, to meet air and tension loads on the mast and aerial. A 2 in. diameter clearance hole is required for entry of the

conductor for the transmitter-receiver termination. The location of the hole, together with the base-plate geometry and attachment bolt pitches, is shown on the aerial mast data sheet supplied to the aircraft manufacturers.

11. The mast will be installed so as to be easily accessible for attachment and removal of the aerial tuning unit connector.

Method of aerial termination

12. The standard method of aerial termination using insulated aerial wire WS25-U (5E/3756) and the chuck unit is as follows:—

RESTRICTED

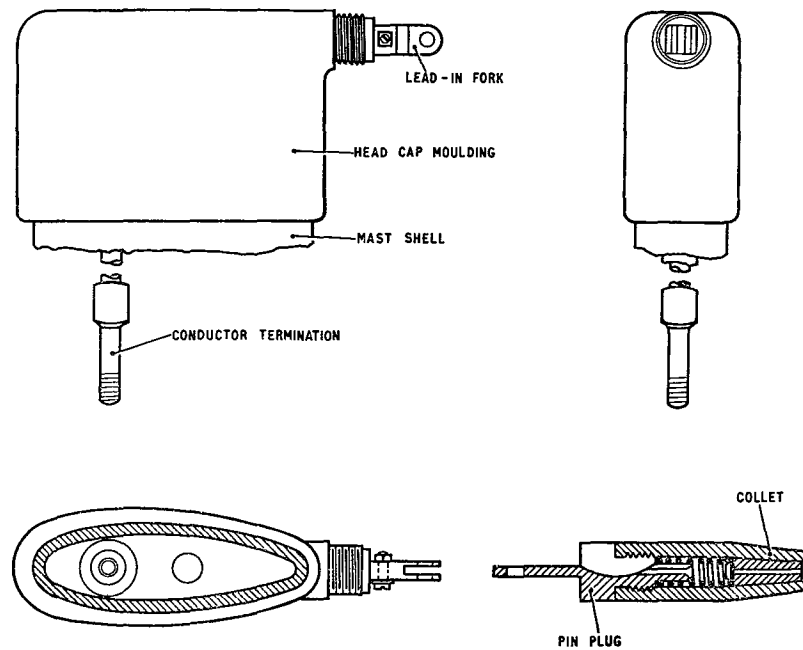

Fig. 2. Mast, aerial Type 69—Head cap moulding.

- (1) Remove the chuck unit by withdrawing the split pin and shackle pin.
- (2) Remove $3\frac{1}{2}$ in. of insulation from the end of the aerial wire.
- (3) Fit the long taper cap (*fig. 1*) over the aerial wire (tapered end first).
- (4) Push the bared end of the aerial wire through the chuck unit. Leave one-quarter inch of bare conductor between the chuck and the insulation of the aerial wire.
- (5) Bend the bared conductor UP through 90 degrees. Refit the chuck unit to the lead-in fork (*fig. 2*) using shackle pin and split pin (*para. 25*).
- (6) Bend the conductor to lay along the lead-in fork and again DOWN to lay in the slot on the side of the fork.
- (7) Secure the conductor with the square washer, screw and nut (*para. 25*).
- (8) Trim off the free end of the conductor. Pack the long taper cap with silicone compound MS.4 and refit.

Modification to terminal shroud

13. The following modification has been introduced to prevent water condensing between the terminal shroud and the insulation which covers the terminal rod. The effect of this condensation was to reduce the insulation resistance measured between the aerial tuning unit terminal of the mast and the aircraft skin to 5 megohms.

14. The procedure for the modification is as follows:—

- (1) Remove the aerial tuning unit terminal nuts and the connecting cable from the aerial tuning unit (*fig. 1*).
- (2) Remove the existing terminal shroud.
- (3) Thoroughly dry the polythene insulation covering the terminal rod.
- (4) Place in position the sealing ring (Seatrist L01/B RT.OS.9).
- (5) Place in position the modified terminal shroud (Part No. B.3032 issue 2).
- (6) Place in position the washer and nut and tighten the nut securely.
- (7) Place the lock nut in position and lock.
- (8) Re-connect the cable terminal from the aerial tuning unit and lock in position (*para. 25*).

15. When this modification has been made, the insulation resistance of the mast (with the connector removed from the aerial tuning unit terminal) must be not less than 40 megohms when tested with a 1000V megger.

GENERAL MAINTENANCE

16. The general maintenance described in the following paragraphs is for information only. Precise maintenance instructions will be given in the Aircraft Maintenance Manual or Vol. 4 of this Air Publication.

RESTRICTED

Insulation breakdown

17. The installation breakdown test has value only with the aerial mast installed on the aircraft, or under conditions *exactly* simulating the same.

18. Disconnect the aerial tuning unit connector from the terminal rod and with a 1,000V insulation tester check the insulation resistance between the airframe skin and the lead-in assembly.

Aerial and mast inspection

19. The following inspections will be carried out at the periods laid down in the aircraft maintenance schedule.

- (1) By visual inspection check that the aerial tension appears normal and the mast and aerial secure.
- (2) Inspect for erosion of paint. Repaint the mast if the exposed area of neoprene exceeds one square inch (*Vol. 4*).
- (3) Check security of mast attachment to airframe.
- (4) Remove the aerial and inspect the terminal fittings for corrosion. Replace defective fittings. Examine the polythene long taper cap for cracks (*fig. 1*).
- (5) Examine the neoprene coating where exposed by erosion of paint, particularly on the leading edge (*Vol. 4*). If the neoprene is eroded on any part of the leading edge and exposes the fibre glass shell the *mast must be renewed*.
- (6) Refit the aerial wire.
- (7) Ensure that the long taper cap is filled with silicone compound MS.4.
- (8) Carry out the insulation resistance test (*para. 18*).

Repairs

20. Normally mast Type 69 will be renewed after a flying time laid down in the aircraft maintenance schedule and returned to the makers for reconditioning.

21. Where it is impracticable to return the mast to the makers, the neoprene repair procedure given below may be followed. Integral lead-in components cannot be repaired.

Neoprene repair

22. Only neoprene to specification DTD.856A is to be used and applied as specified in DTD.926A. Erosion of neoprene is most likely to occur on the aerial mast leading edge where this is within an included angle of 60 degrees to the line of flight.

23. Repairs must be carried out to ensure that the old and the new neoprene surfaces mate to leave no exposed edges that will set up renewed and rapid erosion. Repairs must, therefore extend outside the angular area of erosion.

24. The repair procedure is as follows:—

- (1) If the mast is painted strip the paint with carborundum waterproof paper No. 220C, clean the paint from the affected area. Clean

off resistant paint with methylated spirit. Stripping should extend at least half-inch beyond the area of damaged neoprene.

IMPORTANT NOTE

Methylated spirit is a safe solvent. Cellulose or highly volatile cleaning agents will damage neoprene.

- (2) Allow the methylated spirit to dry out for one hour and proceed with the repair.
- (3) Cut out a 'square' of damaged neoprene ensuring that the edges do not break away. If the cut edge lifts, cut away until all edges are firm.
- (4) Clean the exposed fibre-glass laminate with Tuolene. Mask the cut-out to protect the surrounding neoprene against Tuolene contamination.
- (5) Apply neoprene primer. Use only enough thinners to make the primer easy to work. Allow one hour to dry.

IMPORTANT NOTE

The primer must not contact the edges of the neoprene cut-out. Thinners must not be mixed with neoprene.

- (6) Apply the neoprene with a fine camel hair brush. Allow one hour between each coat. Build up with 20 coats to a thickness of 0.020 in. Each coat is to overlap cut-out by one-quarter inch.
- (7) If the mast is to be finished with paint, seven days drying period must be allowed for the neoprene repair.

Spare parts

25. The manufacturers recommend the following items to be kept as replacement parts:

	<i>Description</i>	<i>Part No.</i>
(1)	<i>Aerial mast</i>	
	Washer (at base of terminal shroud)	3721
	Nut $\frac{1}{4}$ in. BSF (securing nut of terminal shroud)	A53/E
	Lock nut $\frac{1}{4}$ in. BSF (lock-nuts of terminal shroud and connection to aerial tuning unit)	A54/EB
(2)	<i>Aerial Termination</i>	
	Chuck unit	1511
	Long taper cap	3141
	Shackle pin	} Secures chuck unit to forked end of aerial termination
	Split pin	
	Screw 6 BA Square washer	} For electrical connection of aerial wire to aerial termination.
Nut 6 BA	AGS/246/A12 3061 A53/A	

RESTRICTED

Chapter 3

TENSION UNIT, AERIAL, AFT (10B/16897)

LIST OF CONTENTS

	Para.		Para.
<i>Introduction</i>	1	Installation details	18
		<i>Aerial tension</i>	19
		<i>Attachment of aerial and tension unit</i>	20
Mechanical description	3	General testing, dismantling and reassembly	21
<i>Insulator unit</i>	4	<i>Removing the tension unit from the aerial system</i>	22
<i>Chuck unit</i>	5	<i>Dismantling the tension unit</i>	23
<i>Weak link</i>	7	<i>Inspection for damage and wear</i>	25
<i>Tension unit</i>	8	<i>Reassembly of the tension unit</i>	26
<i>The tension unit and airframe distortion</i>	15	<i>Testing and repair</i>	27
		<i>Spare parts</i>	28

LIST OF ILLUSTRATIONS

<i>Tension unit, aerial, aft (10B/16897) with exploded view</i>	Fig. 1
--	-----------

Introduction

1. The tension unit, aerial, aft (10B/16897) is designed for use with wire aerials up to 70 feet in length and with a working tension of up to 70 lb. At the time of writing, the tension unit is used with the Canberra and Hastings aircraft.

2. To meet practical and safety requirements the tension unit, aerial, aft, embodies the following features:—

- (1) Introduces a spring into the aerial run which can take up variations in the aerial span brought about by airframe distortion.
- (2) Provides an adjustable overall length which aids installation and compensates for small physical variations in aerial length.

(3) Gives visual indication of aerial tension.

(4) Includes a compression spring locking device for simplification of installation. The compression on the spring can be adjusted to give variations in tension for different aerial installations.

(5) Incorporates a weak link in accordance with airworthiness requirements.

(6) Includes a line insulator.

MECHANICAL DESCRIPTION

3. General and exploded views of the tension unit are given in fig. 1. The top view shows the unit to have two main parts; the tensioning device and the line insulator. The latter includes a chuck unit for connection to the aerial wire.

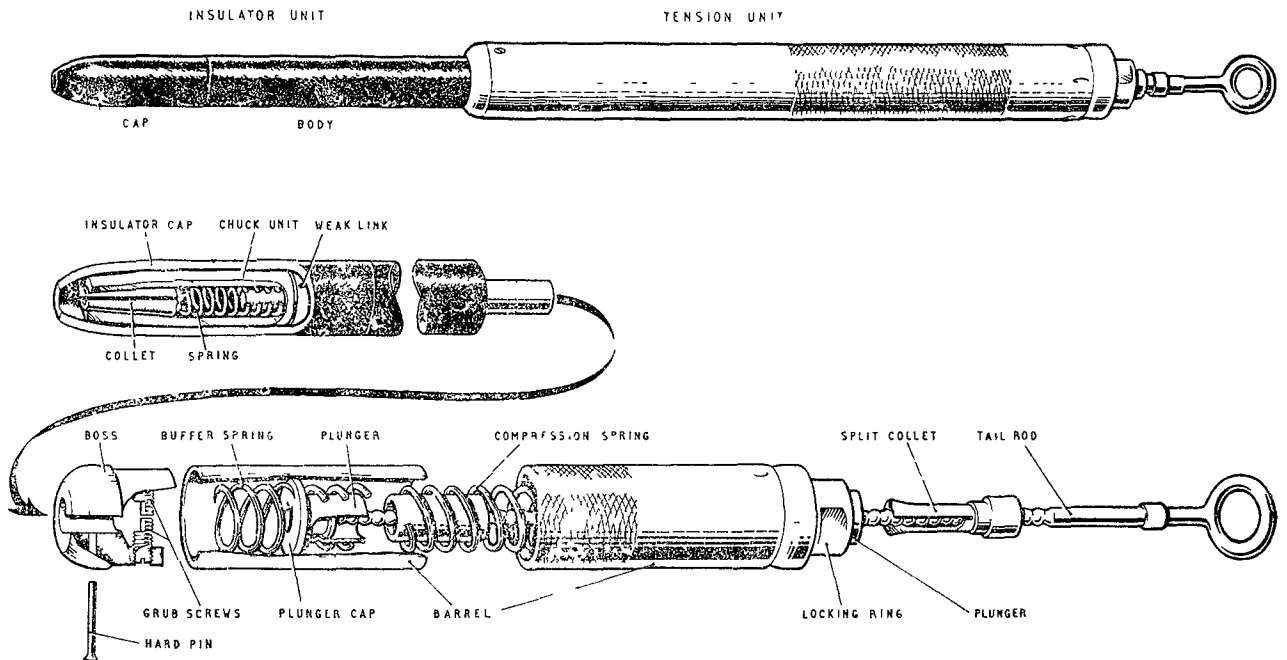

Fig. 1. *Tension unit, aerial, aft (10B/16897) with exploded view*

Insulator unit

4. The interior of the insulator body is not shown but consists of a tubular resinated glass fabric insulator within a moulded black polythene body with integral stainless steel end sockets in which the termination fittings are secured with a steel pin to the tensioning device.

Chuck unit

5. In the exploded view can be seen the chuck unit attached to the "aerial end" of the insulator and protected by a polythene cap. The chuck unit consists of a spring-loaded split collet within a cylindrical housing tapered at the end to which is fitted the aerial wire. When the aerial wire is inserted in the chuck the collet will open against the tension of the spring; when the wire is pulled in the opposite direction the tapered end of the chuck will cause the jaws of the collet to tighten on the wire, thus preventing its removal by force. It should be noted here that the wire can be removed from the chuck by the use of a special tool or by pressure on the jaws of the chuck applied in the opposite direction to the pull of the wire.

6. The chuck unit is given the following A.M. nomenclature: "Terminations, conductor, (tensioning) Type 17", A.M. Ref. No. 10H/22109. It must, of course, be understood that the tension of the wire aerial is not provided by the chuck, but by the tension device described in para. 8. The polythene chuck unit cap is known as "insulator, Type 852", A.M. Ref. No. 10B/16912.

Weak link

7. Provision is made for the chuck unit to be connected to the insulator unit by means of a copper rivet to provide a weak link. In the illustration the weak link is shown in position connecting the chuck unit to the line insulator. This link is a copper rivet (pins, shear, 10AS/3768) and connects the chuck unit to the line insulator in double shear. When the aerial tension exceeds 160-180 lb. the rivet fails; this conforms to the airworthiness requirements for a weak link.

Tension unit

8. The tensioning mechanism includes all that shown in the lower part of the illustration, that is, from the boss to the tail rod. The main parts of the tensioning device are the plunger and compression spring, these are housed in the barrel together with the buffer spring; all are retained in the barrel by the boss which is secured by two grub screws (2BA) in the forward end of the barrel. The boss is the anchorage for the aerial termination components, that is, the insulator unit and chuck unit.

9. The barrel assembly comprises the barrel, barrel ring and locking ring; the barrel ring is not shown in the illustration but is fitted inside the end of the barrel adjacent to the locking ring.

When a load is applied to the tension unit the compression spring is compressed between the plunger cap and barrel ring; the barrel ring cannot rotate relative to the barrel but the locking ring can be rotated to a locked or free position. The plunger passes through the barrel ring and the locking ring, the core holes of both rings are slightly eccentric and when the locking ring is rotated to the locked position by means of a $\frac{5}{16}$ in. BSF spanner, the plunger is squeezed between the eccentric cores and is locked in position. The plunger can be locked in any position to provide various tensions related to the compression of the spring within the barrel (*para.* 11).

10. Within the plunger tube is a collet ring which is flared for engagement of the sprung arms on the split collet when an axial load is applied to the tail rod. The tail rod is shouldered at 0.1 in. pitches and under load the shoulders draw the collet into the collet ring which closes the sprung arms to lock the tail rod to the plunger. The nomenclature for the tail rod is "rod, tensioning (10AS/3770)".

11. With the tail rod locked to the plunger it is possible to pull on the tail rod to extend the plunger through the end of the barrel and thus compress the compression spring. The amount of compression, and thus the amount of extension of the plunger beyond the end of the locking ring, is a measure of the tension provided by the unit.

12. The measurement of the extension and its relation to tension applied to the aerial is described in para. 16, e.g. for a tension of 40 lb. the plunger should be extended to 0.8 inch beyond the locking ring. This dimension can be altered by shifting the tail rod through the collet by one or more shoulders at a time. The shoulders have a pitch of 0.1 inch and this corresponds to a change in tension of 5 lb. (*see Note to para.* 17 (10)).

13. In the event of failure of the weak link the compression spring energy is absorbed by the buffer spring, thus protecting the mechanism.

14. Flats on the two grub screws provide clearance for the entry of the termination of the insulator unit and must be aligned as shown in the illustration (*fig* 1). Particular attention should be paid to the method of attachment of the insulator to the tensioning device before attempting to dismantle the unit. The tension unit will be damaged if any attempt is made to remove the grub screws before disconnecting the insulator (*para.* 20).

The tension unit and airframe distortion

15. The use of a sufficiently high tensile wire for the aerial will allow a considerable degree of airframe distortion before the breaking point is reached. The tensile strength of the WS.25-U aerial wire is between 450 and 520 lb. and a 60 ft. run will stretch six inches beyond its normal working length before breaking. To rely on the wire alone, however, would introduce the following serious disadvantages:—

RESTRICTED

(1) The airframe and mast or other support would need considerable reinforcement.

(2) The wire might break at any point along its length, the most likely place being the forward make-off, with the resulting danger of the free end wrapping itself around control surfaces of the aircraft.

(3) The energy stored in the stretched wire just before failure would be very large and the possibility of damage from the recoil, if suddenly freed, would be considerable.

16. To provide against the wire breaking at a point where interference with the control surfaces might occur, a weak link is fitted at the aft end of the aerial. The airworthiness requirement is that the weak link will fail at about three times the working load of the aerial and this will minimize all three disadvantages referred to in para. 15. The use of a weak link therefore lowers the permissible airframe distortion and a spring unit must be introduced into the aerial run.

17. Both the weak link and the spring are provided by the tension unit and the use of the tension unit introduces compensating advantages. In the first place, a greater distortion can be coped with for a given amount of stored energy, whilst the total energy is divided between the wire and the tension unit, thus greatly reducing the risk of recoil damage. Also the use of a tension unit can simplify and speed up the process of aerial installation and dismantling; it also provides a spring balance on which the aerial tension can be measured almost at a glance.

INSTALLATION DETAILS

18. Airframe attachments are made to the tension unit by a pin joint through the tail rod eye-end. It is important to ensure that the tension unit is free to align with the aerial wire. Attachments are required to withstand a factored load of 180 lb. (A factored load of 180 lb. implies that the attachments are designed to withstand 180 lb. multiplied by any safety factors relevant to the design.)

Aerial tension

19. Aerial tension requirements vary with the aerial span and the type of aircraft to which the aerial is fitted. The tension applied by the tension unit is measured by the extent to which the plunger is pulled out from the barrel against the tension of the spring. The various tensions applied and the associated dimension of the plunger extension is given below.

Aerial	Tension	Extension of plunger
Up to 40 ft.	30—40 lb.	0.6 in.—0.8 in.
40—50 ft.	40—50 lb.	0.8 in.—1.0 in.
50—60 ft.	50—60 lb.	1.0 in.—1.2 in.
60 ft. and over	60—70 lb.	1.2 in.—1.4 in.

Attachment of aerial and tension unit

20. First ascertain the required aerial tension for the aerial span using insulated aerial wire WS25-U (5E/3756) (Chap. 1). Then proceed as follows:—

(1) Release the tail rod by pressing the split collet into the plunger. Pull out the tail rod to its full length (about seven inches). (It is possible to remove the tail rod altogether if required.)

(2) Make off the tail rod to the airframe attachment.

(3) Remove the polythene cap from the chuck unit.

(4) With the aerial wire made off to the lead-in mast or other forward attachment, take the wire in one hand and the tension unit in the other. Hold the wire as taut as can be comfortably achieved and note the length of wire that will just reach the point where the chuck unit is joined to insulator. Cut the wire at this point.

(5) Push the chuck unit polythene cap over the insulated aerial wire. Strip the insulation to bare three-quarters of an inch of conductor and insert this bared wire into the chuck.

(6) Pull up the aerial wire and push the tail rod into the collet as far as possible.

(7) Steady the tension unit by holding the barrel lightly in one hand and lay the forearm along the aerial wire. This permits the aerial wire to be loaded by downward pressure of the elbow and forearm and will avoid bending the wire at the junction with the tension unit.

(8) Bear down on the wire with the forearm and extend the plunger about half as much again as the extension finally required. Lock the plunger with the aid of a $\frac{5}{16}$ in. BSF spanner.

(9) Release the forearm pressure, pull up the unit and push the tail rod in as far as possible. Unlock the plunger.

(10) Measure the plunger extension (para. 19). If this is not correct repeat the procedure in operation (8).

Note . . .

An adjustment may be made after locking the plunger by pushing in, or withdrawing, the tail rod by one notch or shoulder for each 0.1 in. of error in the measured extension. This correction by use of the tail rod should vary the tension by 5 lb. for each 0.1 in. In practice when an aerial is erected and the tension is found to be 5 lb. too low it will not be corrected completely by taking up one notch, because the wire itself will stretch. An extra tension of 5 lb. will stretch a 50 ft. aerial by one-sixteenth inch. On the average it should be anticipated that the increase in tension will be about 3 lb. per notch rather than 5 lb.

(11) Unlock the plunger and check the extension. This should now be correct. If the tension is still incorrect repeat the procedure in operation (10)

(12) When the tension is correct fill the polythene chuck unit cap with silicone compound MS4 and refit.

GENERAL TESTING, DISMANTLING AND REASSEMBLY

21. The tension unit should be periodically inspected for exterior corrosion and free plunger movement. Always ensure that the plunger is *unlocked* after the aerial tension has been correctly applied. The plunger movement may be checked by pulling down on the aerial approximately two feet from the termination, thereby increasing the load on the tension unit.

Removing the tension unit from the aerial system

22. Remove the aerial tension as follows:—

- (1) With the plunger unlocked, first increase the tension on the wire by holding the barrel of the tension unit with one hand and bearing down on the wire with the forearm. Then lock the plunger.
- (2) Pull the tail rod out from the plunger to about six or seven inches, but not right out.
- (3) Again increase the tension on the wire as in operation (1) and then relieve the tension by unlocking the plunger and gradually allowing the plunger to return to its relaxed position.
- (4) Remove the tension unit from the airframe and the aerial wire, and completely dismantle for inspection.

Dismantling the tension unit

23. Before attempting to dismantle the tension unit, particular note should be made of the method of attaching the insulator unit to the tensioning unit. When the stub end of the insulator is fitted into the boss it bears against the flats and therefore “locks” the grub screws which hold the boss in the barrel. Before the grub screws can be moved, the hard pin must be knocked out and the insulator unit removed. The grub screws have a 2BA thread and a 4BA head and must be screwed *in* (not *out*) for removal of the boss. When reassembling, the flats of the grub screws must be aligned as shown in the illustration before the insulator can be inserted.

24. The following instructions assume that the aerial wire has been removed and the tension unit removed from the airframe; the description refers to fig. 1.

- (1) Push against the head of the split collet so that it moves towards the plunger and withdraw the tail rod whilst holding the collet in this position.
- (2) Drive out the hard pin in the boss to release the aerial termination component. Remove the insulator unit from the boss.
- (3) Screw *in* the two grub screws until the heads clear the inner wall of the barrel. Withdraw the boss from the end of the tension unit.
- (4) Remove from the barrel (a) the buffer spring (b) the plunger and (c) the compression spring.
- (5) Withdraw the split collet from the plunger.

Inspection for damage and wear

25. Make the following inspection for damage and wear (*fig. 1*).

- (1) Examine the barrel for dents and the end spinning for cracks.
- (2) Check for elongation of the grub screw holes in the barrel.
- (3) Examine for corrosion and pitting of the barrel, chuck unit and split collet. Clean as required. (A carbon-steel wire brush should not be used to polish up the barrel since this will leave a deposit which will subsequently rust.)
- (4) Examine the tail rod eye-end silver-soldered joint for cracks.
- (5) Check the plunger alignment and free movement within the barrel.
- (6) Check that the freedom of movement of the plunger is such that the dimension referred to in para. 19 (*fig. 1*) does not exceed 0.4 in. when the tension unit is not loaded.
- (7) Reassemble the unit and fit a new weak link rivet (pins, shear (10AS/3768)).

Reassembly of the tension unit

26. The following procedure is to be applied when reassembling the tension unit (*fig. 1*).

- (1) Insert the split collet into the end of the plunger.
- (2) Place the compression spring over the plunger. Insert the plunger in the barrel and at the same time insert the tail rod into the other end of the barrel to engage the split collet in the plunger.
- (3) When the plunger and tail rod are joined, pull the tail rod out through the end of the barrel so that the plunger is drawn through the locking ring. This is only possible if the locking ring is unlocked.
- (4) Now position the buffer spring in the barrel. Fit the boss so that the tapped holes containing the grub screws align with the associated holes in the barrel. Screw the grub screws in a counter-clockwise direction so that they come out through the holes in the barrel. The final position of the grub screws must be with the flats facing forward as seen through the boss (*fig. 1*). The boss is now secured to the barrel and the tension unit is ready to receive the stub end of the insulator unit.
- (5) Fit the connection between the insulator unit and chuck unit with a weak link rivet. Use new rivets only (pins, shear (10AS/3768)).
- (6) Assemble the tension unit to the airframe in accordance with the aircraft manufacturers, instructions and the information in para. 20.

Testing and repair

27. Testing is limited to checking the mechanical function of the tension unit as described in para. 24. Repairs are not permissible and any damaged part of the tension unit must be renewed.

RESTRICTED

Spare parts

28. The manufacturers recommend the following items to be kept as replacement parts.

<i>Description</i>	<i>Part No.</i>
Chuck unit (Terminations, conductor (tensioning)) Type 17, 10H/22109 ...	3510
Chuck cap (Insulator Type 852), 10B/16912	3505
Insulator body moulding ...	3988
Weak link (Pins, shear), 10AS/3768 ...	AS467/205
	rivet
Collet for tail rod ...	3609
Tail rod—with eye-end ...	3611

<i>Description</i>	<i>Part No.</i>
Compression spring ...	3605
Buffer spring ...	3604
Hard pin for boss ...	5389
Grub screw for boss ...	3630
Barrel boss ...	3987
Barrel assembly ...	5391
(including: barrel, barrel ring and locking ring)	
Plunger assembly ...	3606
(including: plunger cap, plunger and collet housing)	

Chapter 4. MAST, AERIAL, TYPE 67

LIST OF CONTENTS

	Para.		Para.
Introduction	1	<i>Modification to terminal shroud</i>	12
General description			
<i>Mast shell</i>	5	General maintenance	15
<i>Head cap and lead-in assembly</i>	7	<i>Insulation breakdown</i>	16
Installation			
<i>Aerial mast to airframe</i>	9	<i>Aerial and mast inspection</i>	18
<i>Method of aerial wire termination to lead-in</i> 11		<i>Repairs</i>	19
		<i>Neoprene repair</i>	21
		<i>Spare parts</i>	24

LIST OF ILLUSTRATIONS

<i>Mast, aerial Type 67—construction</i>	<i>Fig.</i> 1
---	------	------------------

INTRODUCTION

1. Aerial mast Type 67 (10B/16893) is designed for use with fixed aerial applications of ARI.5874 on aircraft to which wire aeriels may be fitted. The mast may be fitted to pressurized or unpressurized aircraft; at the time of writing the mast is used on the Valetta aircraft.

2. A sectional drawing of the aerial mast Type 67 is given in fig. 1. Although the mast cannot be dismantled beyond the removal of aerial termination fittings the mast shell and head cap may be regarded as two separate parts.

3. The complete mast has an overall height of $16\frac{1}{8}$ inches; it is streamlined and destruction tests have shown the following breaking moments:—

- (1) Along fore and aft axis
10,000 in. lb.
- (2) Side load 4,500 in. lb.

4. Electrical tests have been made with the mast mounted on an earthed metal plate simulating the airframe and having a 2 in. diameter hole through which the transmitter-receiver terminal boss projected. Tests were made at 100 kc/s and 1 Mc/s, and in each case the breakdown voltage was found to exceed 20 kilovolts.

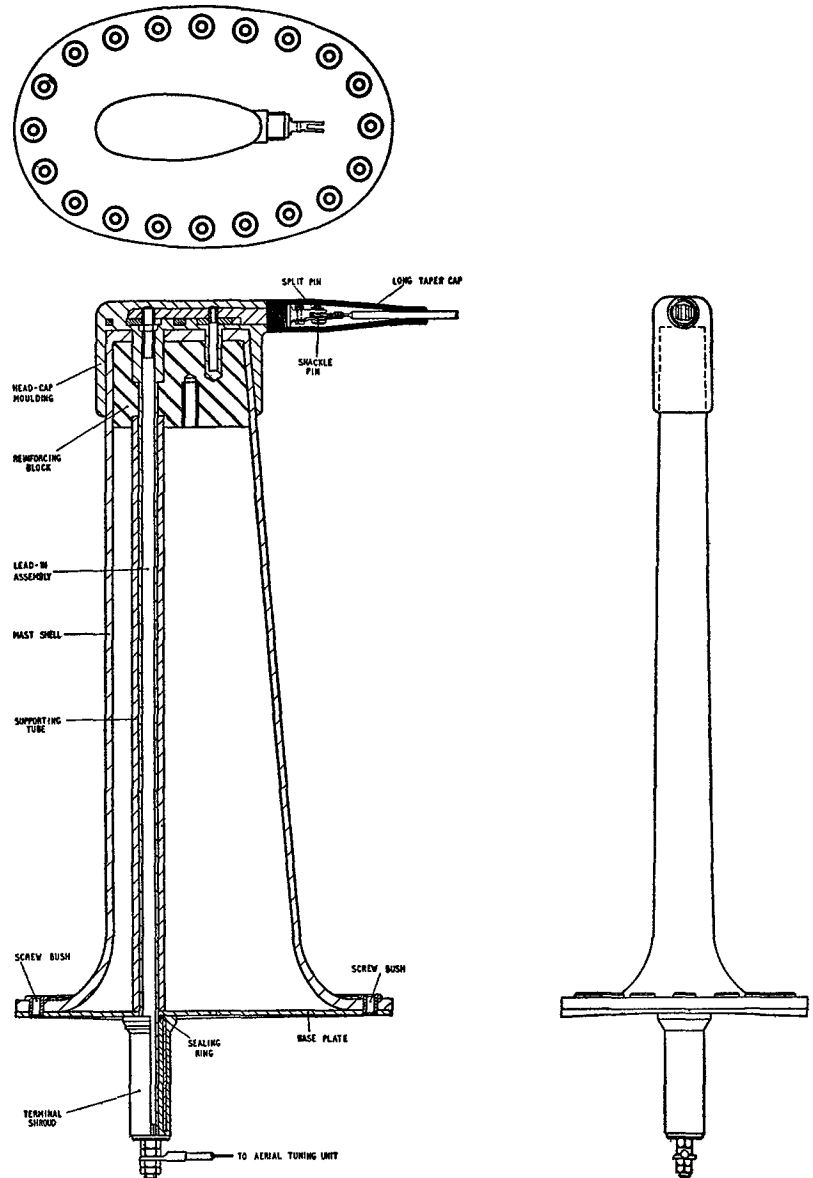

Fig. 1. Mast, aerial Type 67—construction.

GENERAL DESCRIPTION

Mast shell

5. The mast shell is a resin-bonded fibre-glass laminate. A reinforcing block is fitted within the mast head and a tube, extending between the head and base plate, supports the conductor rod (*fig. 1*). The base plate is bonded to the mast shell and flared to form the flange attachment to the aircraft skin. The flange and base plate are drilled and fitted with bushes to accommodate twenty 2 BA bolts.

6. Protection against rain, hail and ice erosion is afforded by coating the shell with neoprene to specification DTD.856A. Twenty coats of neoprene are applied to provide a coating 0.02 in. thick.

Head cap and lead-in assembly

7. The head cap and lead-in assembly consists of the head cap moulding and nickel-plated brass lead-in components. The head cap is moulded in black polythene and, as indicated in the drawing, completely insulates the lead-in components, consisting of the horizontal lead-in fork and the vertical conductor. The vertical conductor extends 4 in. below the base plate to make the aerial tuning unit termination.

8. A terminal shroud over the extended lower end of the conductor serves to clamp the sealing ring introduced by the modification described in para. 12. The shroud is fitted with a washer and secured by a $\frac{1}{4}$ in. BSF nut and locknut. The aerial tuning unit termination is secured with two $\frac{1}{4}$ in. BSF locknuts.

INSTALLATION

Aerial mast to airframe

9. Aircraft skin panels upon which aerial masts are mounted must be reinforced as necessary with a stiffening plate or other structure to meet air and tension loads on the mast and aerial. A 2 in. diameter clearance hole is required for entry of the conductor for the transmitter-receiver termination. The location of the hole, together with the base plate geometry and attachment bolt pitches, is shown on the aerial mast data sheet supplied to the aircraft manufacturers.

10. The mast will be installed so as to be easily accessible for attachment and removal of the aerial tuning unit connector.

Method of aerial wire termination to lead-in

11. The standard method of aerial termination using insulated aerial wire WS25-U (5E/3756) is as follows:—

(1) Remove the long taper cap (insulator Type 853) from the mast head.

(2) Remove the insulation to bare $3\frac{1}{2}$ in. of conductor, taking care not to damage the aerial wire.

(3) Fit the long taper cap (*fig. 1*) over the aerial wire (tapered end first).

(4) Take the bared end of the aerial wire round the roller and round the main wire, six times. Make fast the free end under the square washer and secure with screw and nut.

(5) Trim off the free end of the conductor. Pack the long taper cap with silicone compound MS.4 and refit to the mast head.

Modification to terminal shroud

12. The following modification has been introduced to prevent water condensing between the terminal shroud and the insulation which covers the terminal rod. The effect of this condensation was to reduce the insulation resistance measured between the aerial tuning unit terminal of the mast and the aircraft skin to 5 megohms. Most masts will have been modified, but the method of modification is given in para. 13.

13. The procedure for the modification is as follows:—

(1) Remove the aerial tuning unit termination nuts from the end of the mast conductor and the connecting cable from the aerial tuning unit.

(2) Remove the existing terminal shroud.

(3) Wipe dry the polythene insulation covering the terminal rod.

(4) Place in position the sealing ring (ring, sealing Type 89-10AC/455).

(5) Place in position the modified terminal shroud, insulator (terminal) Type 850 (10B/16911).

(6) Place in position the washer and nut and tighten the nut securely.

(7) Place the locknut in position and lock.

(8) Re-assemble the cable terminal from the aerial tuning unit and lock in position (*para. 24*).

14. When this modification has been made the insulation resistance of the mast (with the connector removed from the aerial tuning unit terminal) must be not less than 40 megohms when tested with a 1000 V megger.

GENERAL MAINTENANCE

15. The general maintenance described in the following paragraphs is for information only. Precise maintenance instructions will be given in the Aircraft Maintenance Manual or Vol. 4 of this Air Publication.

Insulation breakdown

16. The insulation breakdown test has value only with the aerial mast installed on the aircraft, or under conditions *exactly* simulating the same.

RESTRICTED

17. Disconnect the aerial tuning unit connector from the terminal rod and with a 1000 V insulation tester check the insulation resistance between the airframe skin and the lead-in assembly.

Aerial and mast inspection

18. The following inspections should be carried out at the periods laid down in the aircraft maintenance schedule:—

- (1) By visual inspection check that the aerial tension appears normal and the mast and aerial secure.
- (2) Inspect for erosion of paint. Re-paint the mast if the exposed area of neoprene exceeds one square inch (*Vol. 4*).
- (3) Check security of mast attachment to airframe.
- (4) Remove the aerial and inspect the terminal fittings for corrosion. Replace defective fittings. Examine the polythene long taper cap for cracks (*fig. 1*).
- (5) Examine the neoprene coating, where exposed by erosion of paint, particularly on the leading edge. If the neoprene is eroded on any part of the leading edge and exposes the fibre-glass shell the *mast must be renewed*.
- (6) Refit the aerial wire.
- (7) Ensure that the long taper cap is filled with silicone compound MS.4.
- (8) Carry out the insulation resistance test (*para. 17*).

Repairs

19. Normally mast Type 67 will be renewed after a flying time indicated in the aircraft maintenance schedule and returned to the makers for reconditioning.

20. Where it is impracticable to return the mast to the makers, the neoprene repair procedure given below may be followed. Integral lead-in components cannot be repaired.

Neoprene repair

21. Only neoprene to specification DTD.856A is to be used and applied as specified in DTD.926A. Erosion of neoprene is most likely to occur on the aerial mast leading edge where this is within an included angle of 60 degrees to the line of flight.

22. Repairs must be carried out to ensure that the old and the new neoprene surfaces mate to leave no exposed edges that will set up renewed and rapid erosion. Repairs must, therefore, extend outside the angular area of erosion.

23. The repair procedure is as follows:—

- (1) If the mast is painted, strip the paint with carborundum waterproof paper No. 220C, clean the paint from the affected area. Clean off resistant paint with methylated spirit. Stripping should extend at least half-inch beyond the area of damaged neoprene.

Important note . . .

Methylated spirit is a safe solvent. Cellulose or highly volatile cleaning agents will damage neoprene.

- (2) Allow the methylated spirit to dry out for one hour and proceed with the repair.
- (3) Cut out a "square" of damaged neoprene ensuring that the edges do not break away. If the cut edge lifts, cut away until all edges are firm.
- (4) Clean the exposed fibre-glass laminate with Tuolene. Mask the cut-out to protect the surrounding neoprene against Tuolene contamination.
- (5) Apply neoprene primer. Use only enough thinners to make the primer easy to work. Allow one hour to dry.

Important note . . .

The primer must not contact the edges of the neoprene cut-out. Thinners must not be mixed with neoprene.

- (6) Apply the neoprene with a fine camel hair brush. Allow one hour between each coat. Build up with 20 coats to a thickness of 0.020 in. Each coat is to overlap cut-out by one-quarter inch.
- (7) If the mast is to be finished with paint, seven days' drying period must be allowed for the neoprene repair.

Spare parts

24. The manufacturers recommend the following items to be kept as replacement parts:—

	<i>Description</i>	<i>A.M. Ref. No. and/or Manufacturer's Part No.</i>
(1)	<i>Aerial mast</i>	
	Washer (at base of terminal shroud)	3721
	Nut $\frac{1}{4}$ in. BSF (securing nut of terminal shroud)	5355
	Locknut $\frac{1}{4}$ in. BSF (locknuts of terminal shroud and connection to aerial tuning unit)	5356
(2)	<i>Aerial termination</i>	
	Long taper cap (insulator Type 853)	3141 (10B/16913)
	Roller—To take bared end of aerial wire	3151
	Shackle pin } Secures roller to forked end of mast (lead-in) {	SP4/B1
	split pin } termination {	SP9/C4
	Square washer (plates, connector) { For electrical connection of {	3061 (10AS/3769)
	Screw 6 BA } aerial wire to lead-in {	A43/A12
	Nut 6 BA } {	A53/A

RESTRICTED

Chapter 5.

MAST, AERIAL, TYPE 68

LIST OF CONTENTS

	Para.		Para.
Introduction	1	<i>Method of aerial wire termination to chuck units</i>	10
General description		<i>Modification to terminal shroud</i>	11
<i>Mast shell</i>	4	General maintenance	14
<i>Head cap and lead-in assembly</i>	6	<i>Insulation breakdown</i>	15
<i>Chuck unit terminations</i>	8	<i>Aerial and mast inspection</i>	17
Installation		<i>Repairs</i>	18
<i>Aerial mast to airframe</i>	9	<i>Neoprene repair</i>	20
		<i>Spare parts</i>	23

LIST OF ILLUSTRATIONS

	Fig.
<i>Mast, aerial Type 68—construction</i>	1

INTRODUCTION

1. Aerial mast Type 68 (10B/16894) is designed for use with fixed aerial applications of ARI.5874 on aircraft requiring a mast with 2-way terminations such as the Comet. The mast can be fitted to pressurized or unpressurized aircraft.

2. A sectional drawing of the aerial mast Type 68 appears in fig. 1. The mast may be considered as two parts, the head cap and the mast shell. The two parts are not separable, but the forward section of the head cap assembly can be detached as described in para. 8. The complete mast has an overall length of approximately 14 in. and is 7 in. in height, it is streamlined and destruction tests have shown the following breaking moments:—

- (1) Along fore and aft axis 10,000 in. lb.
- (2) Side load 4,500 in. lb.

3. Electrical tests have been made with the mast mounted on an earthed metal plate simulating the airframe and having a 2 in. diameter hole through which the transmitter-receiver terminal boss projected. Tests were made at 100 kc/s and 1 Mc/s, and in each case the breakdown voltage was found to exceed 20 kilovolts.

GENERAL DESCRIPTION

Mast shell

4. The mast shell is a resin-bonded fibre-glass laminate. A reinforcing block is fitted within the mast head and a tube, extending between the head and base plate, supports the conductor rod (*fig. 1*). The base plate is bonded to the mast shell and flared to form the flange attachment to the aircraft skin. The flange and base plate are drilled and fitted with bushes to accommodate fifteen 2 BA bolts.

5. Protection against rain, hail and ice erosion is afforded by coating the shell with neoprene to specification DTD.856A. Twenty coats of neoprene are applied to provide a coating 0.02 in. thick.

Head cap and lead-in assembly.

6. The head cap and lead-in assembly consists of the head cap moulding (*fig. 1*) and nickel-plated brass lead-in components. The head cap is moulded in black polythene and, as indicated in the drawing, completely insulates the lead-in components, consisting of the two horizontal fork connections and the vertical conductor. The vertical conductor extends 4 in. below the base plate to make the aerial tuning unit termination.

7. A terminal shroud over the extended lower end of the conductor serves to clamp the sealing ring introduced by the modification described in para. 11. The shroud is fitted with a washer and secured by a $\frac{1}{4}$ in. BSF nut and locknut. The aerial tuning unit termination is secured with two $\frac{1}{4}$ in. BSF locknuts.

Chuck unit terminations

8. To connect the ends of the insulated aerial wire to the mast lead-in, two chuck units are used; these are shown in *fig. 1*, which illustrates how the chuck unit assemblies can be connected to the lead-in forks. Each chuck unit consists of a spring-loaded split chuck within a knurled housing, the whole being retained by a plug end which is the male connection to the lead-in forked end. The chuck unit is assembled to the fork by a shackle pin secured by a split pin. The forward chuck unit assembly is, in effect, the rear termination of the forward section of the aerial wire. The chuck unit therefore includes a weak link in accordance with airworthiness requirements. A chuck adaptor is fitted and is held in position together with the screw-threaded boss by means of a $\frac{1}{8}$ in. copper rivet which acts as the weak link (*fig. 1*).

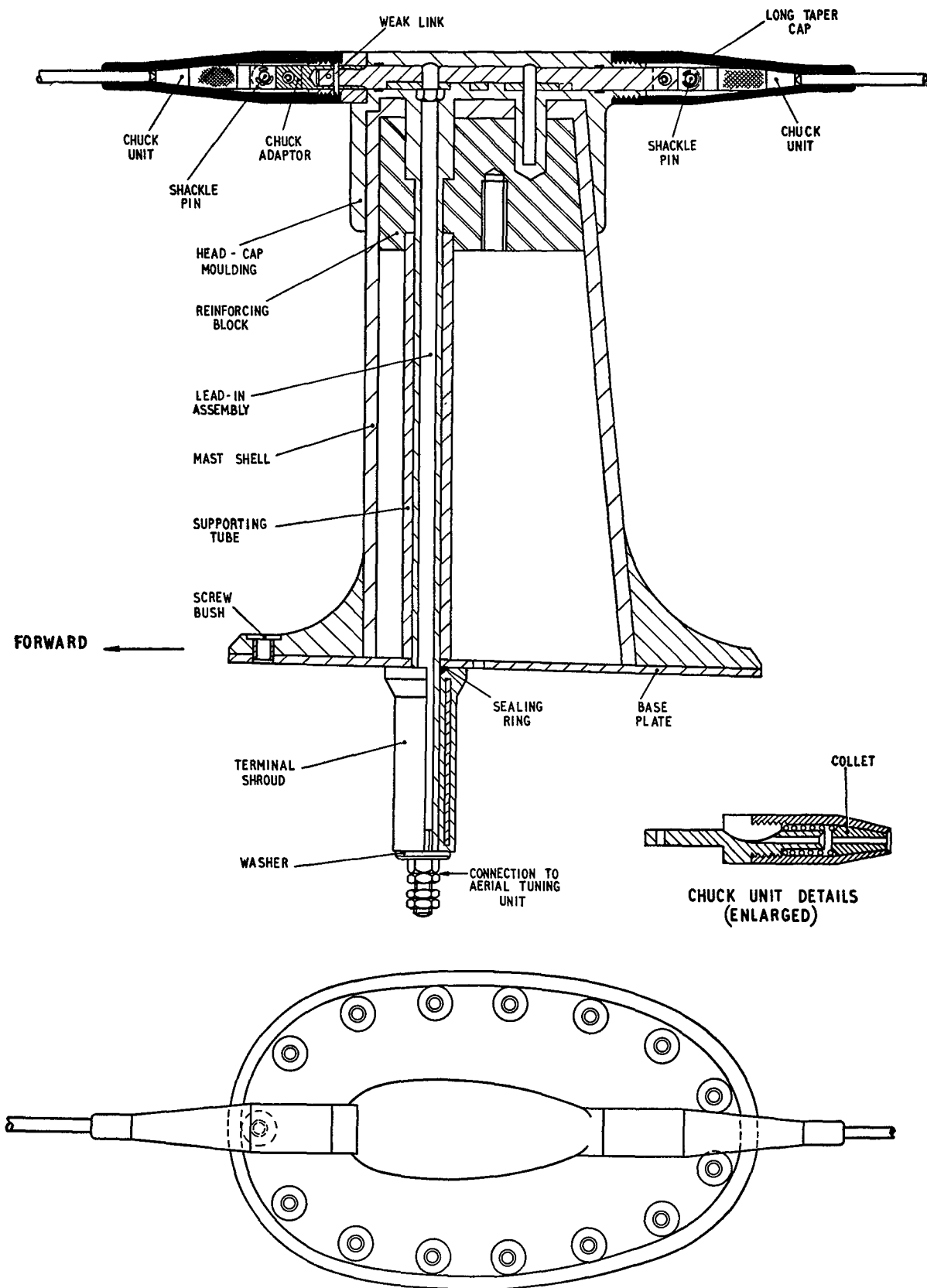

Fig. 1. Mast, aerial Type 68—construction.

RESTRICTED

INSTALLATION**Aerial mast to airframe**

9. Aircraft skin panels upon which aerial masts are mounted must be reinforced as necessary with a stiffening plate or other structure to meet air and tension loads on the mast and aerial. A 2 in. diameter clearance hole is required for entry of the conductor for the transmitter-receiver termination. The location of the hole, together with the base plate geometry and attachment bolt pitches, is shown on the aerial mast data sheet supplied to the aircraft manufacturers. The mast will be installed so as to be easily accessible for attachment and removal of the aerial tuning unit connector.

Method of aerial wire termination to chuck units

10. The standard method of aerial termination, using insulated aerial wire WS25-U (5E/3756) and a chuck unit, is as follows:—

- (1) Unscrew and remove the long taper cap.
- (2) Remove the chuck unit by withdrawing the split pin and shackle pin.
- (3) Remove 3½ in. of insulation from the end of the aerial wire.
- (4) Fit the long taper cap (*fig. 1*) over the aerial wire (tapered end first).
- (5) Push the bared end of the aerial wire through the chuck unit. Leave one-quarter inch of bare conductor between the chuck and the insulation of the aerial wire.
- (6) Bend the bared conductor up through 90 degrees. Refit the chuck unit to the lead-in fork (*fig. 2*), using shackle pin and split pin.
- (7) Bend the conductor to lay along the lead-in fork and again down to lay in the slot on the side of the fork.
- (8) Secure the conductor with the square washer, screw and nut.
- (9) Trim off the free end of the conductor. Pack the long taper cap with silicone compound MS.4 and refit over the chuck unit.

Modification to terminal shroud

11. The following modification has been introduced to prevent water condensing between the terminal shroud and the insulation which covers the terminal rod. The effect of this condensation was to reduce the insulation resistance measured between the aerial tuning unit terminal of the mast and the aircraft skin to 5 megohms. Most masts should now incorporate this change, but the method of modification is given in para. 12.

12. The procedure for the modification is as follows:—

- (1) Remove the aerial tuning unit terminal nuts and the connecting cable from the aerial tuning unit.
- (2) Remove the existing terminal shroud.
- (3) Thoroughly dry the polythene insulation covering the terminal rod.
- (4) Place in position the sealing ring (Seatrist L01/B RT.OS.9).
- (5) Place in position the modified terminal shroud (Part No. B.3032 issue 2—insulator (terminal) Type 850).
- (6) Place in position the washer and nut, and tighten the nut securely.
- (7) Place the locknut in position and lock.
- (8) Reconnect the cable terminal and the aerial tuning unit, and lock in position (*para. 23*).

13. When this modification has been made the insulation resistance of the mast (with the connector removed from the aerial tuning unit terminal) must be not less than 40 megohms when tested with a 1 000 V megger.

GENERAL MAINTENANCE

14. The general maintenance described in the following paragraphs is for information only. Precise maintenance instructions will be given in the Aircraft Maintenance Manual or Vol. 4 of this Air Publication.

Insulation breakdown

15. The insulation breakdown test has value only with the aerial mast installed on the aircraft, or under conditions *exactly* simulating the same.

16. Disconnect the aerial tuning unit connector from the terminal rod and with a 1 000 V insulation tester check the insulation resistance between the airframe skin and the lead-in assembly.

Aerial and mast inspection

17. The following inspections will be carried out at the periods laid down in the aircraft maintenance schedule:—

- (1) By visual inspection check that the aerial tension appears normal and the mast and aerial secure.
- (2) Inspect for erosion of paint. Re-paint the mast if the exposed area of neoprene exceeds one square inch (*Vol. 4*).

- (3) Check security of mast attachment to air-frame.
- (4) Remove the aerial wire and inspect the terminal fittings for corrosion. Replace defective fittings. Examine the polythene long taper caps for cracks (fig. 2). Renew the weak link in the forward chuck adaptor as required (Vol. 4).
- (5) Examine the neoprene coating where exposed by erosion of paint, particularly on the leading edge. If the neoprene is eroded on any part of the leading edge and exposes the fibre-glass shell the mast *must be renewed*.
- (6) Refit the aerial wire.
- (7) Ensure that each of the long taper caps are filled with silicone compound MS.4.
- (8) Carry out the insulation resistance test (para. 15).

Repairs

18. Normally mast Type 68 will be renewed after a flying time indicated in the aircraft maintenance schedule and returned to the makers for reconditioning.

19. Where it is impracticable to return the mast to the makers, the neoprene repair procedure given below may be followed. Integral lead-in components cannot be repaired.

Neoprene repair

20. Only neoprene to specification DTD.856A is to be used and applied as specified in DTD.926A. Erosion of neoprene is most likely to occur on the aerial mast leading edge where this is within an included angle of 60 degrees to the line of flight.

21. Repairs must be carried out to ensure that the old and the new neoprene surfaces mate to leave no exposed edges that will set up renewed and rapid erosion. Repairs must, therefore, extend outside the angular area of erosion.

22. The repair procedure is as follows:—

- (1) If the mast is painted, strip the paint with carborundum waterproof paper No. 220C, clean the paint from the affected area. Clean off resistant paint with methylated spirit. Stripping should extend at least half-inch beyond the area of damaged neoprene.

Important note . . .

Methylated spirit is a safe solvent. Cellulose or highly volatile cleaning agents will damage neoprene.

- (2) Allow the methylated spirit to dry out for one hour and proceed with the repair.
- (3) Cut out a "square" of damaged neoprene ensuring that the edges do not break away. If the cut edge lifts, cut away until all edges are firm.
- (4) Clean the exposed fibre-glass laminate with Tuolene. Mask the cut-out to protect the surrounding neoprene against Tuolene contamination.
- (5) Apply neoprene primer. Use only enough thinners to make the primer easy to work. Allow one hour to dry.

Important note . . .

The primer must not contact the edges of the neoprene cut-out. Thinners must not be mixed with neoprene.

- (6) Apply the neoprene with a fine camel hair brush. Allow one hour between each coat. Build up with 20 coats to a thickness of 0.020 in. Each coat is to overlap cut-out by one-quarter inch.
- (7) If the mast is to be finished with paint, seven days' drying period must be allowed for the neoprene repair.

Spare parts

23. The manufacturers recommend the following items to be kept as replacement parts:—

	<i>Description</i>	<i>A.M. Ref. No. and/or Manufacturer's Part No.</i>
(1) <i>Aerial mast</i>		
	Washer (at base of terminal shroud)	3271
	Nut ¼ in. BSF (securing nut of terminal shroud)	5355
	Locknut ¼ in. BSF (locknuts of terminal shroud and connection to aerial tuning unit)	5356
(2) <i>Aerial termination</i>		
	Chuck unit (2)	1511 (10H/22110)
	Long taper cap (2) (insulator Type 853)	3141 (10B/16913)
	Shackle pin } Secures chuck unit to forked end of aerial	SP4/B1
	Split pin } termination	SP9/C4
	Square washer (plate, connector) } For electrical connection of	3061 (10AS/3769)
	Screw 6 BA } aerial wire to aerial ter-	A43/A12
	Nut 6 BA } mination	A53/A
	Weak link (pin, shear)	AS467/205 (10AS/3768)

RESTRICTED

Chapter 6

TENSION UNIT, AERIAL, FORWARD (10B/16899) AND TENSION UNIT, AERIAL, AFT (10B/16898)

LIST OF CONTENTS

	Para.		Para.
Introduction	1	<i>Setting up the aft tension unit</i>	21
<i>Mechanical description</i>	3	<i>Setting up the forward tension unit</i>	22
<i>Tensioning device</i>	4	General testing, dismantling and reassembly	23
<i>Forward tension unit</i>	11	<i>Removing the tension unit from the aerial system</i>	24
<i>Aft tension unit</i>	12	<i>Dismantling the tension unit</i>	25
<i>Chuck unit</i>	13	<i>Inspection for damage and wear</i>	27
<i>Weak link</i>	15	<i>Reassembly of the tension unit</i>	28
<i>The tension unit and airframe distortion</i>	16	<i>Testing and repair</i>	29
Installation details	19		
<i>Aerial tension</i>	20		

LIST OF ILLUSTRATIONS

	Fig.
<i>Aerial tension unit—tensioning mechanism</i>	1
<i>Tension unit, aerial, forward (10B/16899)</i>	2
<i>Tension unit, aerial, aft (10B/16898)</i>	3

INTRODUCTION

1. The tension unit, aerial, forward (10B/16899), and tension unit, aerial, aft (10B/16898), are designed for use with wire aerials on the Comet aircraft with the double-termination mast Type 68 (Chap. 5). The forward tension unit is linked to an insulator Type 844 which provides an insulator and chuck unit for connection to the aerial wire (para. 11).

2. For operational and safety requirements the tension units have the following advantages:—

- (1) Introduction of a spring in the aerial run which can take up variations in the aerial span brought about by airframe distortion.
- (2) Provision of an adjustable overall length which aids installation and compensates for small physical variations in aerial length.
- (3) Visual indication of aerial tension.
- (4) Inclusion of a compression spring locking device for simplification of installation. The compression on the spring can be adjusted to

give variations in tension for different aerial installations.

(5) Incorporation of a weak link in accordance with airworthiness requirements. (The weak link is included only in the tension unit, aerial, aft.)

Mechanical description

3. The tensioning device of each type of tension unit is identical and an exploded view is given in fig. 1. The terminations at the aerial end of the two tension units are illustrated in fig. 2 and fig. 3. The tension unit, aft, includes a chuck unit for connection to the aerial wire.

Tensioning device

4. The tensioning mechanism includes all that shown in the illustration (fig. 1), that is, from the boss to the tail rod. The main parts of the tensioning device are the plunger and compression spring, these are housed in the barrel together with the buffer spring and all are retained in the barrel by the boss, which is secured by two grub screws (2 BA) in the forward end of the barrel (para. 11).

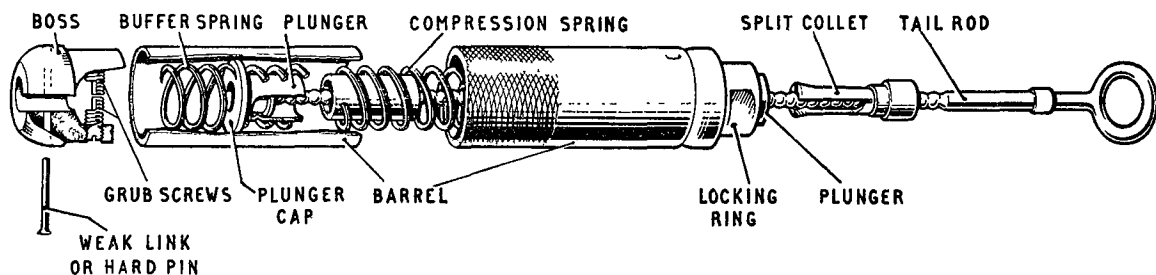

Fig. 1. Aerial tension unit—tensioning mechanism

5. The barrel assembly comprises the barrel, barrel ring and locking ring; the barrel ring is not shown in the illustration, but is fitted inside the end of the barrel adjacent to the locking ring. When a load is applied to the tension unit the compression spring is compressed between the plunger cap and barrel ring; the barrel ring cannot rotate relative to the barrel, but the locking ring can be rotated to either a locked or free position. The plunger passes through the barrel ring and the locking ring; the core holes of both rings are slightly eccentric, and when the locking ring is rotated to the locked position by means of a $\frac{5}{16}$ in. BSF spanner, the plunger is squeezed between the eccentric cores and is locked in position. The plunger can be locked in any position to provide various tensions related to the compression of the spring within the barrel (*para. 7*).

6. Within the plunger tube is a collet ring which is flared for engagement of the spring arms on the split collet when an axial load is applied to the tail rod. The tail rod is shouldered at 0.1 in. pitches and under load the shoulders draw the collet into the collet ring which closes the sprung arms to lock the tail rod to the plunger. The nomenclature for the tail rod is "rod, tensioning (10AS/3770)".

7. With the tail rod locked to the plunger it is possible to pull on the tail rod to extend the plunger through the end of the barrel and thus "squeeze" the compression spring. The amount of compression, and thus the amount of extension

of the plunger beyond the end of the locking ring, is a measure of the tension provided by the unit.

8. The measurement of the extension and its relation to tension applied to the aerial is described in *para. 16*, e.g., for a tension of 40 lb. the plunger should be extended to 0.8 in. beyond the locking ring. This dimension can be altered by shifting the tail rod through the collet by one or more shoulders at a time. The shoulders have a pitch of 0.1 in. and this corresponds to a change in tension of about 5 lb. (*See Note to para 21 (10).*)

9. In the event of failure of the weak link the compression spring energy is absorbed by the buffer spring, thus protecting the tensioning mechanism.

10. Flats on the two grub screws provide clearance for the entry of the stub end of the termination and must be aligned as shown in the illustration (*fig. 1*). Particular attention should be paid to the method of attachment of the termination to the tensioning device before attempting to dismantle the unit. The tension unit will be damaged if any attempt is made to remove the grub screws before disconnecting the termination (*para. 25*).

Forward tension unit

11. The forward tension unit has a simple termination consisting of an eye-plug connected to an extension at the end of the basic tension unit.

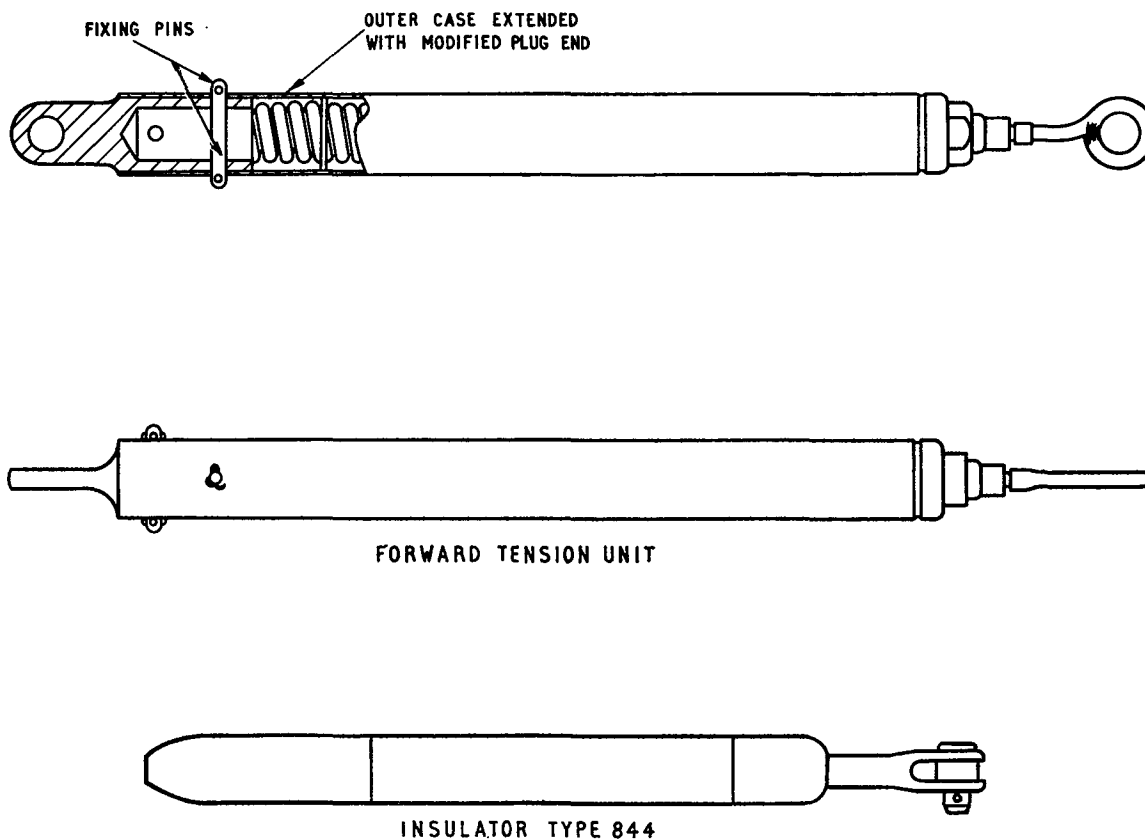

Fig. 2. Tension unit, aerial, forward (10B/16899)

RESTRICTED

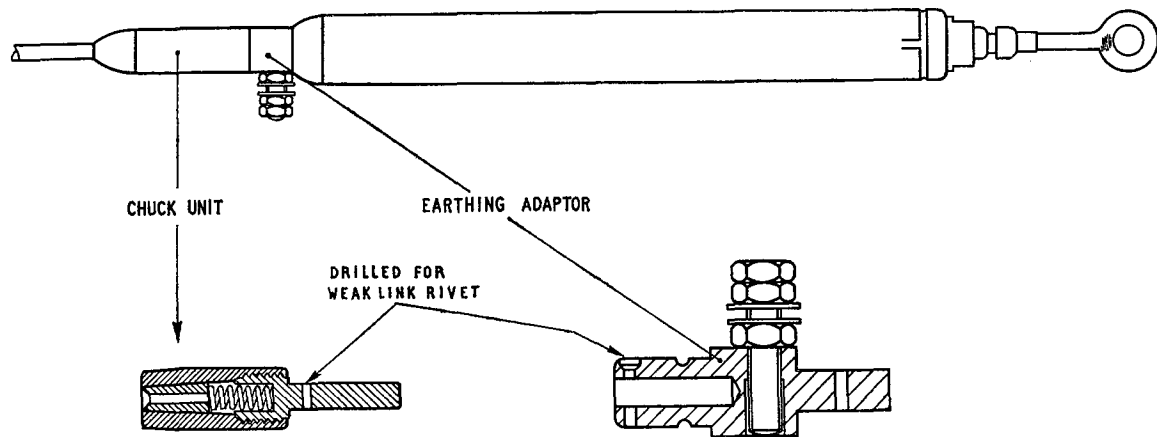

Fig. 3. Tension unit, aerial, aft (10B/16898)

The eye-plug termination is in effect a modification to the end of the tension unit illustrated in fig. 1. The modification includes the removal of the boss (fig. 1) and lengthening of the barrel to enable the eye-plug to be fitted as shown in fig. 2. The eye-plug is secured by two fixing pins which are in turn retained by split pins. The eye-plug is designed for attachment to the airframe, whilst the eye of the tail rod mates with the fork-end of the insulator Type 844 (fig. 2). The insulator unit has a chuck unit at its other end for connection to the aerial wire.

Aft tension unit

12. The aft tension unit is terminated with a chuck unit and earthing adaptor. The chuck unit is designed to grip the aerial wire and the earthing adaptor is fitted with nuts and washers to which may be connected an earth lead. The constructional details of the earthing adaptor are given in fig. 3.

Chuck unit

13. In the illustration of the aerial tension unit, aft (fig. 3) can be seen the chuck unit attached to the "aerial end" of the tension device and protected by a polythene cap. The chuck unit consists of a spring-loaded split collet within a cylindrical housing tapered at the end to which is fitted the aerial wire. When the aerial wire is inserted in the chuck the collet will open against the tension of the spring; when the wire is pulled in the opposite direction the tapered end of the chuck will cause the jaws of the collet to tighten on the wire, thus preventing its removal by force. It should be noted here that the wire can be removed from the chuck by the use of a special tool or by pressure on the jaws of the chuck applied in the opposite direction to the pull of the wire.

14. The chuck unit is given the following A.M. nomenclature "Terminations, conductor (tensioning), Type 17", A.M. Ref. No. 10H/22109. It must, of course, be understood that the tension of the wire aerial is not provided by the chuck,

but by the tension device described in para. 8. The polythene chuck unit cap is known as "insulator, Type 852", A.M. Ref. No. 10B/16912.

Weak link

15. Provision is made for the chuck unit to be connected to the earthing adaptor by means of a copper rivet to provide a weak link. In the illustration the weak link is shown in position connecting the chuck unit to the earthing adaptor. This link is a copper rivet (pins, shear, 10AS/3768) and connects the chuck unit to the earthing adaptor in double shear. When the aerial tension exceeds 160-180 lb. the rivet fails; this conforms to the airworthiness requirements for a weak link.

The tension unit and airframe distortion

16. The use of a sufficiently high tensile wire for the aerial will allow a considerable degree of airframe distortion before the breaking point is reached. The tensile strength of the WS.25-U aerial wire is between 450 and 520 lb. and a 60 ft. run will stretch six inches beyond its normal working length before breaking. However, to rely on the wire alone would present the following serious disadvantages:—

- (1) The airframe and mast or other support would need considerable reinforcement.
- (2) The wire might break at any point along its length, the most likely place being the forward make-off, with the resulting danger of the free end wrapping itself around control surfaces of the aircraft.
- (3) The energy stored in the stretched wire just before failure would be very large and the possibility of damage from the recoil if suddenly freed would be considerable.

17. To provide against the aerial wire breaking at a point where interference with the control surfaces might occur, a weak link is fitted at the aft end of the aerial. The airworthiness requirement is that the weak link will fail at about three

times the working load of the aerial and this will minimize all three disadvantages referred to in para. 16. The use of a weak link, therefore, lowers the permissible airframe distortion and a spring unit must be introduced into the aerial run.

18. Both the weak link and the spring are provided by the tension unit, and the use of the tension unit introduces compensating advantages. In the first place, a greater distortion can be coped with for a given amount of stored energy, whilst the total energy is divided between the wire and the tension unit, thus greatly reducing the risk of recoil damage. Secondly, the use of a tension unit can simplify and speed up the process of aerial installation and dismantling. Finally, it provides a spring balance on which the aerial tension can be measured quite simply.

INSTALLATION DETAILS

19. It is important to ensure that the tension unit is free to align with the aerial wire. Attachments are required to withstand a factored load of 180 lb. (A factored load of 180 lb. implies that the attachments are designed to withstand 180 lb. multiplied by any safety factors relevant to the design.)

Aerial tension

20. Aerial tension requirements vary with the aerial span and the type of aircraft to which the aerial is fitted. The tension applied by the tension unit is measured by the extent to which the plunger is pulled out from the barrel against the tension of the spring. The various tensions applied and the associated dimension of the plunger extension is given below:—

Aerial (ft.)	Tension (lb.)	Extension of plunger (inches)
Up to 40	30-40	0.6-0.8
40-50	40-50	0.8-1.0
50-60	50-60	1.0-1.2
60 and over	60-70	1.2-1.4

Setting up the aft tension unit

21. First ascertain the required aerial tension for the aerial span using insulated aerial wire WS25-U (5E/3756) (Chap. 1). Then proceed as follows:—

- (1) Release the tail rod by pressing the split collet into the plunger. Pull out the tail rod until about 2 in. remain in the collet. (It is possible to remove the tail rod altogether if required.)
- (2) Make off the tail rod to the airframe attachment.
- (3) Remove the polythene cap from the chuck unit (para. 22).
- (4) With the aerial wire made off to the lead-in mast or other forward attachment, take the wire in one hand and the tension unit in the other. Hold the wire as taut as can be comfortably

achieved and note the length of wire that will just reach the point where the chuck unit is joined to the insulator. Cut the wire at this point.

(5) Push the chuck unit polythene cap over the insulated aerial wire. Strip the insulation to bare three-quarters of an inch of conductor and insert this bared wire into the chuck.

(6) Pull up the aerial wire and push the tail rod into the collet as far as possible.

(7) Steady the tension unit by holding the barrel lightly in one hand and lay the forearm along the aerial wire. This permits the aerial wire to be loaded by downward pressure of the elbow and forearm and will avoid bending the wire at the junction with the tension unit.

(8) Bear down on the wire with the forearm and extend the plunger about half as much again as the extension finally required. Lock the plunger with the aid of a $\frac{1}{8}$ in. BSF spanner.

(9) Release the forearm pressure, pull up the unit and push the tail rod in as far as possible. Unlock the plunger.

(10) Measure the plunger extension (para. 20). If this is not correct repeat the procedure in sub-para. (8).

Note . . .

An adjustment may be made after locking the plunger by pushing in, or withdrawing, the tail rod by one notch or shoulder for each 0.1 in. of error in the measured extension. This correction by use of the tail rod should vary the tension by 5 lb. for each 0.1 in. In practice when an aerial is erected and the tension is found to be 5 lb. too low it will not be corrected completely by taking up one notch, because the wire itself will stretch. An extra tension of 5 lb. will stretch a 50 ft. aerial by $\frac{1}{8}$ in. On the average it should be anticipated that the increase in tension will be about 3 lb. per notch rather than 5 lb.

(11) Unlock the plunger and check the extension. This should now be correct. If the tension is still incorrect repeat the procedure in sub-para. (10).

(12) When the tension is correct fill the polythene chuck unit cap with silicone compound MS4 and refit.

Setting up the forward tension unit

22. The procedure for tensioning the forward tension unit will be similar to that for the aft tension unit previously described (para. 21); the tail unit is pulled out as described in sub-para (1). The tension unit and insulator Type 844 are now held out in "line astern" and the wire cut so as to reach the junction of the chuck and the insulator.

RESTRICTED

GENERAL TESTING, DISMANTLING AND REASSEMBLY

23. The tension unit should be periodically inspected for exterior corrosion and free plunger movement. Always ensure that the plunger is *unlocked* after the aerial tension has been correctly applied. The plunger movement may be checked by pulling down on the aerial approximately two feet from the termination, thereby increasing the load on the tension unit.

Removing the tension unit from the aerial system

24. The following procedure is based on the removal of the aft tension unit. The method for the forward tension unit will be similar. Remove the aerial tension as follows:—

- (1) With the plunger unlocked, first increase the tension on the wire by holding the barrel of the tension unit with one hand and bearing down on the wire with the forearm. Then lock the plunger.
- (2) Pull the tail rod out from the plunger to about six or seven inches, but not right out.
- (3) Again increase the tension on the wire as in (1) and then relieve the tension by unlocking the plunger and gradually allowing the plunger to return to its relaxed position.
- (4) Remove the tension unit from the airframe and the aerial wire, and completely dismantle for inspection.

Dismantling the tension unit

25. Before attempting to dismantle the tension unit, particular note should be made of the method of attaching the termination to the tensioning device. When the stub end of the termination is fitted into the boss it bears against the flats and therefore “locks” the grub screws which hold the boss in the barrel. Before the grub screws can be moved, the hard pin must be knocked out and the termination removed. The grub screws have a 2 BA thread and a 4 BA head, and must be screwed *in* (not *out*) for removal of the boss. When reassembling, the flats of the grub screws must be aligned as shown in the illustration (*fig. 1*) before the termination can be inserted.

26. The following instructions assume that the aerial wire has been removed and the tension unit removed from the airframe; the description refers to *fig. 1*:—

- (1) Push against the head of the split collet so that it moves towards the plunger and withdraw the tail rod whilst holding the collet in this position.
- (2) Drive out the hard pin in the boss to release the aerial termination component. Remove the unit from the boss.

(3) On the aft tension unit screw *in* the two grub screws until the heads clear the inner wall of the barrel. Withdraw the boss from the end of the tension unit.

(4) Remove from the barrel (a) the buffer spring, (b) the plunger and (c) the compression spring.

(5) Withdraw the split collet from the plunger.

Inspection for damage and wear

27. Make the following inspection for damage and wear (*fig. 1*):—

- (1) Examine the barrel for dents and the end spinning for cracks.
- (2) Check for elongation of the grub screw holes in the barrel.
- (3) Examine for corrosion and pitting of the barrel, chuck unit and split collet. Clean as required. (A carbon steel wire brush should not be used to polish up the barrel, since this will leave a deposit which will subsequently rust.)
- (4) Examine the tail rod eye-end silver-soldered joint for cracks.
- (5) Check the plunger alignment and free movement within the barrel.
- (6) Check that the freedom of movement of the plunger (*fig. 1*) is such that the dimension referred to in para. 20 does not exceed 0.4 in. when the tension unit is not loaded.
- (7) Reassemble the unit as described in para. 28.

Reassembly of the tension unit

28. The following procedure is to be applied when reassembling the tension unit (*fig. 1*):—

- (1) Insert the split collet into the end of the plunger.
- (2) Place the compression spring over the plunger. Insert the plunger in the barrel and at the same time insert the tail rod into the other end of the barrel to engage the split collet in the plunger.
- (3) When the plunger and tail rod are joined, pull the tail rod out through the end of the barrel so that the plunger is drawn through the locking ring. This is only possible if the locking ring is unlocked.
- (4) On the aft tension unit position the buffer spring in the barrel. Fit the boss so that the tapped holes containing the grub screws align with the associated holes in the barrel. Screw the

grub screws in a counter-clockwise direction so that they come *out* through the holes in the barrel. The final position of the grub screws must be with the flats facing forward as seen "through" the boss (*fig. 1*). The boss is now secured to the barrel and the tension unit is ready to receive the stub end of the termination (chuck adaptor).

(5) In the aft tension unit secure the chuck adaptor to the tension unit boss with a hard pin ($\frac{1}{8}$ in. dia. S.80 steel—Part No. 5289). The chuck unit (Part No. 3510) is secured to the chuck adaptor with a weak link (pin, shear—10AS/3786). Use new rivets only. In the forward tension unit the boss is held in place by two stainless steel pins (Part No. 5316) held by SP9/C4 split pins.

(6) Assemble the tension unit to the airframe in accordance with the aircraft manufacturers' instructions and the information in para. 21.

Testing and repair

29. Testing is limited to checking the mechanical function of the tension unit as described in para. 26. Repairs are not permissible and any damaged part of the tension unit must be renewed.

Aerial tension unit, aft (10B/16898)

30. The manufacturers recommend the following items to be kept as spare parts:—

<i>Description</i>	<i>Part No.</i>
Chuck unit (termination, conductor, tensioning) Type 17, 10H/22109	3510
Chuck cap (insulator Type 852), 10B/16912	3505
Weak link (pins, shear—10AS/3768)	AS467/205 rivet
Collet for tail rod	3609*
Tail rod (rod, tensioning—10AS/3770)	3611
Compression spring	3605
Buffer spring	3604
Hard pin for boss	5389
Grub screw for boss	3630
Barrel boss	3987*
Barrel assembly (including: barrel, barrel ring and locking ring)	—
Plunger assembly (including: plunger cap, plunger and collet housing)	3606*

Aerial tension unit, forward (10B/16899)

31. The manufacturers recommend the following items to be kept as spare parts:—

<i>Description</i>	<i>Part No.</i>
Eye-plug	5315*
Fixing pin (2)	5316
Split pin (2)	SP9/C4
Buffer spring	3604
Compression spring	3605
Tail rod (rod, tensioning—10AS/3670)	3611

* Spares of Part No. 3609, 3987, 3606 and 5315 are not a guaranteed fit, and where difficulties occur it may be necessary to return the tension unit to the manufacturers for repair.

RESTRICTED

Chapter I

TEST BENCH RIG AND TEST EQUIPMENT REQUIREMENTS

(This chapter supersedes that issued with (A.L.19))

LIST OF CONTENTS

	Para.		Para.
Introduction	1	Associated Air Publications	6
Test equipment	3	Test bench rig for ARI.5874	7
Bench power supplies	4	Connector sets	9

LIST OF TABLES

	Table		Table
List of test equipment required for 2nd-line servicing ...	1	Connector set for test rig installation, Type 7471 ...	5
Test bench rig requirements	2	Connector set for test rig installation, Type 7472 ...	6
Meter panel assembly—components	3	Connector for ground testing receiver, R.4187 ...	7
Connector set for test rig installation, Type 7470 ...	4		

LIST OF ILLUSTRATIONS

	Fig.		Fig.
Assembly and connections of artificial suppressed aerial	1	Test rig bench layout for ARI.5874	2

Introduction

1. The general servicing information in this Part 2 is intended to assist in the interpretation of the Bay Servicing Schedule laid down in Vol. 4, Part 6 of this publication.

2. This chapter describes the construction of the bench test rig for use with suppressed and fixed aerial installations of ARI.5874 and lists the test equipment required to carry out 2nd-line servicing. The general servicing information on installations with suppressed aerials and fixed wire aerials is given in Chap. 2, 3 and 4. "Special to type" test equipment is described in Chap. 5. Further information on fixed-wire aerials is given in Part 1, Sect. 4.

TEST EQUIPMENT

3. Servicing bays carrying out 2nd-line servicing of ARI.5874 will require the following test equipment (Table 1) including "special to type" items. The bench test rig includes a complete set of units of ARI.5874, and these are included in the recommended items for the test rig layout described in para. 7 to 9. The "number off" each item will in most cases depend on the local requirements of the unit servicing bays. The test bench is to be made up to the instructions given in the Tables. Dimensions and general layout of bench are also illustrated in fig. 1 and 2.

TABLE I

List of test equipment required for 2nd-line servicing

Item	Ref. No.	Nomenclature	Power supply requirements	Remarks
		<i>General Items:—</i>		
1	10A/12160	Headband, Type C	—	
2	10A/13466	Receivers, telephone head, Type 32	—	2 off, 75 ohms impedance
3	10A/14381	Microphone assembly Type 48	—	
		<i>or</i>		
3A	10AH/18	Microphone assembly, Type 71	—	

(Note . . . Items 1 and 3 may be issued as 10AH/141—Headset Type 9)

RESTRICTED

TABLE I—contd.

Item	Ref. No.	Nomenclature	Power supply requirements	Remarks
4	10S/1	Testmeter, Type F	—	Multimeter
5	10S/16599	Signal generator, Type 65B	—	Video oscillator, 25 c/s to 5 Mc/s in two bands.
5A	10S/16446	Signal generator, Type 65A <i>or</i>	100-125V <i>or</i> 200-250V at 40/100 c/s	
5B	10S/16344	Signal generator, Type 65		
6	10K/17631	Transformer, Type 3236		Produces square waves in the range 50 c/s to 150kc/s. FortestsatAF
7	10S/16780	Signal generator CT218	110-250V 45-100 c/s	For use with signal generator Type 65, 65A and 65B.
8	10S/831	Oscilloscope Type 13A	115-230V 50 c/s	FM/AM. 85 kc/s. 30 Mc/s. Output impedance 75 ohms and 7.5 ohms. For tests at IF and RF.
9	10S/16400	*Test set, Type 193A	80, 110, 115, 180 and 230V at 50 to 2,000 c/s	Double beam 2 c/s to 10 Mc/s, 1 mS to 40 mS.
10	10AF/98	Wattmeters, absorption CT44		Crystal activity tester. Freq. range 3 to 10 Mc/s.
11	10S/16308	Multimeter electronic CT38 <i>or</i>	200-250V 45-55 c/s	Wattmeter AF
11A	10S/16373	Valve voltmeter CT54		Measures AC and DC voltage and currents, AC output power and resistance.
12	110T/16	Frequency meter set SCR.211 <i>or</i>	Internal batteries	Valve voltmeter CT54
12A	10T/565	Wavemeter W1191A	Internal batteries	Frequency meter (U.S.A.) 125 kc/s to 20 Mc/s, alternatives to W1191A (crystal unit not required).
13	10S/16494	Test rig, installation, Type 7470		Frequency meter 100 kc/s to 20 Mc/s with provision for crystal control.
14	10S/16495	Test rig, installation, Type 7471		For ARI.5874 less Aerial Systems (Table 4).
15	10S/16496	Test rig, installation, Type 7472		For suppressed Aerial Systems (Table 5).
16	10S/16761	Indicator, output Type 7712		For wire aerial system (Table 6). 70-ohm load (para. 6).
<i>Items recommended for Wire Aerial System</i>				
17	10S/16773	Load, artificial, Type 7771		(Para. 6.)
<i>Items recommended for Suppressed Aerial System</i>				
18	10L/293	Control unit, Type 7216		(Para. 6.)
19	—	Artificial suppressed aerial		To be made up in accordance with assembly instructions in fig. 1.

*Already scaled at one per station for 2nd line use.

RESTRICTED

TABLE I—contd.

Item	Ref. No.	Nomenclature	Power supply requirements	Remarks
20	10B/16859	Impedance matching unit, Type 7949		To be fitted to artificial suppressed aerial assembly (<i>fig. 1</i>).
21	10D/19833	Tuning unit, (Aerial) Type 7016		To be mounted in association with artificial suppressed aerial assembly (<i>fig. 1</i>).
22	10S/16589	Leak indicator kit, CT106		For tuning unit, (aerial), Type 7016.
23	10S/16588	Leak indicator, CT105		As for item 22.
24	110SB/123	Pressurizing kit (pump pressurizing 20/UP)		U.S.A. type.
		<i>or</i>		
24A	4G/5435	Pump pressurizing		A.M. type.
<i>General items recommended special to type</i>				
25	10D/19066	Junction boxes, Type 4191		
26	10L/16204	Control unit, (Remote) Type 4189		
<i>Items for general use</i>				
27	10AG/60	Tools, tuning		This item is "C" store and is for use with control unit 4190 or 4243 and receiver R4187. It will require frequent replacement.
<i>Items recommended for testing receiver R.4187</i>				
28	10HZ/19611	Socket, Type 704		For connecting signal generator CT.218 to receiver R.4187.
29	10XAE/68	Crystal-unit extractor		Tongs for ZDH crystal units.
30	10AB/6	Extractors, Type 2		For lamps.
31	10S/16752	Testmeter (current), Type 7626		0-200 μ A.
32	Z90289	Valve extractor		For B7G and B9A valves.
<i>Items recommended for station fitting</i>				
33	10AG/50	Jigs, locating, (Backplate 10AR/444)		For tuning units (aerial), Type 7180.
34	10AG/51	Jigs, locating, (Backplate 10AR/438)		For power and radio unit, Type 4192.
35	10AG/52	Jigs, locating, (Backplate 10AR/440)		For transmitter, T4188.
36	10AG/53	Jigs, locating, (Backplate 10AR/441)		For control units 4190 or 4243.
37	10AG/54	Jigs, locating, (Backplate 10AR/442)		For receiver R.4187.
38	10AG/55	Jigs, locating, (Backplate 5UC/6011)		For voltage regulator 5UC/6010.
39	10AG/56	Jigs, locating, (Backplate 10AR/474)		For selector unit, Type 7003.

RESTRICTED

Item	Ref. No.	Nomenclature	Power supply requirements	Remarks
40	5K/2576	Sleeve insulating, Type 1		(meter panel assembly)
41	5K/2577	Sleeve insulating, Type 2		(meter panel assembly)
42	5K/2266	Connecting tag, 4 amp., No. 1		(meter panel assembly)
43	5K/2269	Thimble cable, 4 amp., No. 1		(meter panel assembly)
44	5K/2863	Terminal block, 10-way		For MIC. TEL and KEY leads from meter panel.
45	5H/2	Terminal block, ferrule, 3-way		For power supplies input to test rig.
46	5H/8	Terminal block, ferrule, cover		For power supplies input to test rig.
47	5H/16	Socket assembly, 19 amp.		For power supplies input to test rig.
48	10H/4183	Terminals, Type 62		4BA red (meter panel).
49	10H/18549	Terminals, Type 105		4BA black (meter panel).
50	10F/Z510501	Switch, toggle, S.P. "ON/OFF"		3 amp. (meter panel).
51	5Q/707	Voltmeter 0-40 volts		(meter panel).
52	5Q/2560	Circuit breaker 35A No. 5		(meter panel).
53	10H/8241	Socket, Type 33		Mic-Tel. socket, panel.
54	10A/7741	Keys, Morse, Type F		Connected to meter panel.

Bench power supplies

4. The items of ARI.5874 require a nominal bench supply of 28V DC. Some of the individual items of test equipment will require an AC mains supply (Table 1). The 28V DC supply is applied direct to the equipment and is also connected via voltage regulator 5UC/6010 to supply a stabilized voltage of 19V.

5. The power consumption of the complete ARI. 5874 is as follows:—

(1) Transmitter:—	28 volts DC (amps)	19 volts DC (amps)	Power input (watts at 28 volts)
Transmitting CW (Mark) ...	20.0	6.1	750
MCW (Mark) ...	26.5	6.1	910
R/T (normal speech) ...	23.5	6.1	830
Standby ...	1.3	6.1	210*

* Increased by 30 watts approx.
when a channel is being selected.

(2) Receiver:—

Power consumption	28 volts DC (amps)	19 volts DC (amps)	Power input (watts at 28 volts)
Receiver ON (Oven ON) ...	3.8	2.7	185*
Receiver ON (Oven OFF) ...	2.8	2.7	155*

* Increased by 10 watts approx.
when a channel is being selected.

(3) Maximum total power requirements at 28 volts is 1,135 watts.

Associated Air Publications

6. Items of test equipment which are used for 2nd-line servicing of ARI.5874 and have not been covered in other Air Publications are briefly described in Chap. 5. Copies of the following Air Publications should be demanded as required.

Item	Air Publication
Signal generator Type 65	A.P.2879AD
Signal generator CT218	A.P.2563CF
Signal generator Type 56	A.P.2879D
Oscilloscope Type 13	A.P.2869Z
Oscilloscope Type 13A	A.P.2879AF
Test set Type 193A	A.P.2536C, Vol. 1, Part 1, Sect. 3, Chap. 1.
Multimeter Type CT38	A.P.2879AG
Valve voltmeter Type CT54	A.P.2536C, Vol. 1, Sect. 1, Chap. 1.
Wattmeters, absorption Type CT44	A.P.2536C, Vol. 1, Part 1, Sect. 5, Chap. 3.
Wavemeter Type W1191A	A.P.2879B
Test rig installation Type 7470	Chap. 5
Test rig installation Type 7471	Chap. 5
Test rig installation Type 7472	Chap. 5
Load, artificial, Type 7771	Chap. 5
Indicator output (RF 70 ohms) Type 7712	Chap. 5
Leak indicator kit CT106	A.P.2563B
Leak locator CT105	A.P.2563BX
Test meter (current) Type 7626	Chap. 5

RESTRICTED

TEST BENCH RIG FOR ARI.5874

7. A test bench rig can be made up from the drawing in fig. 2. The constructional details are based on R.A.E. drawings with amendments to incorporate an "artificial" suppressed aerial (fig. 1).

8. The following items (Table 2) will be required to construct the test bench and rig with facilities for testing equipment for fixed and suppressed aerials (for connector sets see para. 9).

TABLE 2
Test bench rig requirements

Item	Details
(1) Standard workbench with minimum dimensions:— length 8 ft., width 2 ft. 9 in.	A larger bench may be used but the standard length of the connectors must be taken into account when preparing the layout (see "Connector sets").
(2) Brass or aluminium angle, $\frac{3}{4}$ in. \times $\frac{3}{4}$ in. \times 16 SWG	Two 7 ft. lengths are screwed to the bench with countersunk head woodscrews. The inside faces of the two strips must be vertical and 1 ft. $2\frac{7}{8}$ in. apart. A check must be made along the full length to ensure that the inside faces are parallel. The vertical face of the front strip will be 3 in. from the front edge of the bench.
(3) Mounting assembly, Type 7667 (10AJ/235)	For voltage regulator unit. Consists of two side panels and back-plate (5UC/6011).
Note . . . <i>The mounting assemblies (item 3, 4, 5, 6, 7, 8 and 9) are issued complete with back-plates in position. The side members are cut away to give access to the unit when servicing. Should any part become unserviceable, the mounting assembly must be renewed as a complete unit.</i>	
(4) Mounting assembly, Type 7668 (10AJ/236)	For power and radio unit, Type 4192. Consists of two side panels and back-plate (10AR/438).
(5) Mounting assembly, Type 7669 (10AJ/237)	For control units, Type 4190 and 4243. Consists of two side panels and back-plate (10AR/441).
(6) Mounting assembly, Type 7670 (10AJ/238)	For receiver Type R.4187. Consists of two side panels and back-plate (10AR/442).
(7) Mounting assembly, Type 7671 (10AJ/239)	For transmitter, Type T.4188. Consists of two side panels and back-plate (10AR/440).
(8) Mounting assembly, Type 7666 (10AJ/234)	For selector unit, Type 7003 (suppressed aerial). Consists of two side panels and back-plate (10AR/474).
(9) Mounting assembly, Type 7672 (10AJ/240)	For tuning unit (aerial), Type 7180. Consists of side panels and back-plate (10AR/444).
(10) Meter panel assembly	To be made up to and mounted on the test bench as shown in fig. 2, inset D. For components see Table 3.
(11) Control unit mounting bar	2 off. To be made up to drawing in fig. 2, inset B. For mounting control unit, Type 4189 and Type 7216 on test bench in accordance with fig. 2.
(12) Terminal block 10-way (5X/2863)	To be mounted adjacent to meter panel. To take MIC, TEL, KEY, and switch leads from meter panel and from "Intercom" connector.
(13) Terminal block 3-way (5H/2) and cover (5H/8)	For 28-volt and 19-volt input to test bench. See "Wiring of Power supplies" in fig. 2, inset C.

RESTRICTED

TABLE 2—contd.

Item	Details
(14) Socket assembly, 19-amp. (5H/16)	3 off. Required for use with (13).
(15) Key, Morse, Type F (10A/7741)	For connection to "Key" terminals on meter panel assembly.
(16) Control unit, Type 4189 (10L/16204)	Remote control unit of ARI.5874. For permanent mounting on bench as shown in fig. 2.
(17) Control unit, Type 7216 (10L/293)	Part of suppressed aerial system, Type 9205. For permanent mounting on bench as shown in fig. 2.
(18) Junction box, Type 4191	Part of ARI.5874. For permanent mounting on top of bench as shown in fig. 2.
(19) Indicator, output, Type 7712 (10S/16761)	RF output indicator. For permanent mounting on top of bench as shown in fig. 2.
(20) Impedance matching unit (Type 7947)	Part of suppressed aerial system, Type 9205. For permanent mounting as shown in fig. 1 and 2.
(21) Aerial tuning unit Type 7016 (10D/19242)	Part of suppressed aerial system, Type 9205. For permanent mounting on the bench as shown in fig. 1 and 2.
(22) Artificial load Type 7771 (10S/16773)	For use with fixed wire aerial tuning unit, Type 7180 (10D/19238).

TABLE 3

Meter panel assembly—components (fig. 2, inset D)

Ref. No.	Nomenclature	Remarks
5Q/707	Voltmeter 0-40 volts	Panel mounting
5Q/2560	Circuit breaker 35A No. 5	(remove trip guard)
10H/8241	Socket, Type 33	Mic/Tel socket. Panel mounting.
10F/Z510501	Switch, toggle, S.P.	3-amp. "ON/OFF"
10H/4183	Terminals, Type 62	4BA red, 3 off
10H/18449	Terminals, Type 105	4BA black, 3 off
5K/2576	Sleeve insulating, Type 1	17 off
5K/2577	Sleeve insulating, Type 2	6 off
5K/2266	Connecting tag, 4-amp. No. 1	(Z.19934.) Quick release type. 7 off
5K/2269	Thimble cable, 4-amp. No. 1	(Z.19979.) 7 off
—	Washers, plain, 4BA	8 off. Steel cadmium plated
—	Washers, plain, 6BA	3 off. Steel cadmium plated.
5K/1493	Cable ends, eye, 4BA, channel end.	12 off.
	Cable, electric, WT PVC, flex, as follows:—	
5E/2702	2.5 amp. red	As required
5E/2701	2.5 amp. blue	As required
5E/2703	2.5 amp. white	As required
5E/2698	2.5 amp. black	As required
5E/2700	2.5 amp. yellow	As required
5E/2562	2.5 amp. pink, screened	As required
—	Cleats large	2 off
—	Cleats small	2 off

CONNECTOR SETS

9. The following connector sets are part of the test rig installation as indicated and are issued for use with the test bench:—

- (1) Connector set for test rig installation 7470— for use with ARI.5874 less aerial system (Table 4).
- (2) Connector set for test rig installation 7471—

for use with (suppressed) aerial system, Type 7215 (Table 5).

- (3) Connector set for test rig installation 7472— for use with fixed aerial system of ARI.5874 (Table 6).
- (4) Connector for receiver R.4187 ground testing (Table 7).

RESTRICTED

TABLE 4
CONNECTOR SET FOR TEST RIG INSTALLATION, TYPE 7470
 The connectors in this Table are required for the test bench installation excluding aerial equipment

Ref. No.	Type No.	End A	Destination sleeve marking	End B	Length	Remarks
10HA/15647	EX/20C/1	Control unit, Type 4190 (1A)	Power and radio unit (3A) 4192		5 ft. 6 in.	<i>Pin to Pin:</i> Wire 6145-100179 to Pin No. 1, 4, 5, 6, 7, 8, 9, 10, 11, 12, 13, 15, 16, 17, 18, 19, 20 Wire 6145-100229 to Pin No. 2, 3, 14
10HA/15648	EX/20C/2	Power and radio unit (3D) 4192	Trans T.4188 (2D)		4 ft. 6 in.	<i>Pin to Pin:</i> Wire 6145-100168 to Pin No. 3, 4, 5, 8, 10, 13, 14, 19, 20, 28 Wire 6145-100179 to Pin No. 6, 7, 9, 11, 12, 16, 17, 25, 27, 15 Wire 6145-100229 to Pin No. 1, 2, 24 Wire 6145-100249 to Pin No. 22
10HA/15649	E23/40F/1	Power and radio unit (3F) 4192	Intercomm.		L 3 ft. 0 in. L1 0 ft. 3 in. (Tags 5X/2266 Thimble 5X/2269 Sleeves 5K/2576)	INTERCOMM. CONNECTIONS <i>Colour</i> 1 Red 2 Blue 3 Green 4 Yellow 5 White 6 Black 7, 8 — <i>Sleeve</i> Tel. Pos. Tel. Neg. & E Mic. Mic. Key Low power switch Earth (Screen)
10HA/15662	EX/40F/1	TX shorting plug (3J)	—			Short pins 1 and 2 with tinned copper wire 22 SWG. Cover with PVC sleeving
10HA/15651	EX/50F/3	Receiver R.4187 (4M)	Power supply		L 6 ft. 6 in. L1 0 ft. 3 in.	{ Power supply connections—3 off Unipren 12 Pin 4 1 3 Sleeve 24V E 19V

RESTRICTED

TABLE 4—contd.

Ref. No.	Type No.	Destination sleeve marking		Length	Remarks
		End A	End B		
10HA/15650	EX/20C/3	Receiver R.4187 (4N)	Power and radio unit (3N) 4192	7 ft. 0 in.	<i>Pin to Pin:</i> Wire 6145-100249 to Pin No. 1 Wire 6145-100179 to Pin No. 2, 3, 4.
10HA/15653	EX/50F/4	Power and radio unit (3P) 4192	Power supply	L 2 ft. 9 in. L1 0 ft. 3 in.	Dupren 35 Unipren 12 Pin Nos. 1 to 10 cores to be marked "Earth" (Cable Dupren 35 blue). Pin Nos. 13 to 20 cores to be marked "28V Pos." (Cable Dupren 35 Red). Pin Nos. 11 and 12 cores to be marked "19V Pos." (Cable Dupren 12).
10HA/15654	E14/30B/1	Receiver 4187 (4AD)	J. Box 4191 (12AD)	3 ft. 0 in.	Pin to letter consecutive.
10HA/15655	E14/30B/2	Control unit	J. Box 4191	2 ft. 0 in.	Pin to letter consecutive
10HA/15657	B14/20A/6	J. Box 4191 (12AH)	Control unit 4189 (11AH)	4 ft. 3 in.	—
10HA/15656	EX/50F/5	Voltage regulator	Supply	L 2 ft. 0 in. L1 0 ft. 3 in.	Dupren 35, Unipren 12. Pins 1 to 7 cores to be marked "24V Pos. IN" (Cable Dupren 35 Red). Pin 12 core to be marked "EARTH" (Cable Unipren 12). Pins 13 to 15 and 17 to 20 to be marked "19V Pos. OUT" (Cable Dupren 35 Blue).
10HA/15658	D265/32C/1	Control unit 4190 (1B)	Trans. T.4188 (2B)	4 ft. 0 in.	Uniradio 65
10HA/15659	D265/32C/2	Control unit 4190 (1C)	Trans. T.4188 (2C)	4 ft. 3 in.	Uniradio 65
10HA/15660	D265/32C/3	Power and radio unit (3E) 4192	Trans. T.4188 (2E)	5 ft. 0 in.	Uniradio 65
10HA/15661	D265/32C/4	Control unit 4190 (1L)	Receiver R.4187 (4L)	4 ft. 3 in.	Uniradio 65

RESTRICTED

TABLE 5

CONNECTOR SET FOR TEST RIG INSTALLATION, TYPE 7471

The connectors in this Table are required when testing a suppressed aerial installation on the test bench rig. They will be additional to the connector set for test rig installation, Type 7470

Ref. No.	Type No.	End A	Destination sleeve marking	End B	Length	Remarks
10HA/15632	E14/20C/1	Control unit 4190 (1AF)	Selector unit, Type 7003 (13AF)		7 ft. 0 in.	Pin to Pin 1-25
10HA/15633	E31/30B/1	Selector unit, Type 7003 (13AA)	Aerial control unit, 7216 (14AA)		10 ft. 0 in.	Pin to letter consecutive *18 Metvinsmall 12.5
10HA/15634	E14/30C/2	Selector unit, Type 7003 (13AB)	Aerial tuning unit, Type 7016 (15AB)		6 ft. 0 in.	Pin to letter consecutive. (Cores not required cut back).
10HA/15635	D265/31C/1	Control unit 4190 (1AG)	Imp. matching unit, Type 7949 (16AG)		4 ft. 6 in.	Uniradio 65
10HA/15631	B12/20D/6	Tuning unit (15AC) (Aerial) 7016	Imp. matching unit (16AC)		4 ft. 6 in.	—
10HA/15636	D243/50E/1	Imp. matching unit (16AL)	Probe		3 ft. 0 in.	Uniradio 43

TABLE 6

CONNECTOR SET FOR TEST RIG INSTALLATION, TYPE 7472

This connector set is used when testing fixed wire aerial installations on the test bench. It will be additional to connector set for test rig installation, Type 7470

Ref. No.	Type No.	End A	Destination sleeve marking	End B	Length	Remarks
10HA/15626	E14/30C/1	Control unit 4243 (1S)	ATU (8S)		7 ft. 0 in.	Pin to pin 1-25
10HA/15627	D265/20A/1	Control unit 4243 (1R)	TX output (joins End A of D265/33C/1)		1 ft. 0 in.	Uniradio 65 End A (S) Z.549027 Straight Z.970145 Z.970146 Sleeve 5K/2579

RESTRICTED

TABLE 6—contd.

Ref. No.	Type No.	End A	Destination sleeve marking	End B	Length	Remarks
10HA/15628	D265/30B/1	IND. R.F.	IND. R.F. (16AG)		2 ft. 6 in.	Uniradio 65 <i>End A</i> (S) Z.560044 Straight outlet Z.970113 Sleeve Z.970146 Sleeve 5K/2579 <i>End B</i> (P) Z.560044 Angle outlet Z.970113 Sleeves Z.970145, Z.970146 Sleeve 5K/2579
10HA/15629	10155	ATU (8W)	(not marked) will connect to artificial load, Type 7771		3 ft. 0 in.	<i>End A</i> Moulded socket, Type 1307. 10H/20378 <i>End B</i> None
10HA/15630	D265/33C/1	ATU (joins End B of D265/20A/1)	ATU (8R)		2 ft. 6 in.	<i>End A</i> (S) Z.560044 Straight Z.970145 Z.970146 Sleeve 5K/2579 <i>End B</i> (S) Z.549027 Angle

TABLE 7
CONNECTOR FOR GROUND TESTING RECEIVER, R.4187

Ref. No.	Type No.	End A	Destination sleeve marking	End B	Length	Remarks
10HA/15641	EX/20C/5	IF AMP PL1	CHASS. ASS. SK2		1 ft. 6 in.	6145-100245 equipment wire pin-to-pin (12 off).

RESTRICTED

Chapter 2

GENERAL SERVICING OF RECEIVER-TRANSMITTER EQUIPMENT

(This chapter supersedes that issued with A.L. No. 29)

LIST OF CONTENTS

	Para.		Para.
<i>Introduction</i>	1	<i>Transmitter Type T.4188</i>	
<i>Dismantling and general servicing notes</i>		<i>Dismantling...</i>	22
<i>Receiver Type R.4187</i>	3	<i>Tuning unit covers</i>	24
<i>Power unit</i>	8	<i>Chassis assembly Type 4210</i>	25
<i>Selector unit Type 4230</i>	10	<i>Removing the blower motor</i>	32
<i>Adjustment of gears of RF unit mechanical drive unit...</i>	12	<i>Power and radio unit Type 4192</i>	34
<i>Clicker switch SIG on main chassis assembly...</i>	13	<i>Modulator unit</i>	36
<i>Control unit Type 4190</i>	14	<i>Filter unit Type 4213</i>	38
<i>Resistor unit Type 4217</i>	17	<i>Power unit</i>	39
<i>Panel (control) Type 7246</i>	19	◀ <i>Relay, magnetic Type 1536 (RL1/3—Transmitter Type</i>	
<i>Motor unit Type 4214</i>	20	<i>T.4188)</i> ▶	43▶

INTRODUCTION

1. First and second line servicing information on the receiver-transmitter equipment is given in the form of servicing schedules in Volume 4, Parts 2, 3, 4 and 6 of this Air Publication. For information on third line servicing reference should be made to Volume 6 (limited distribution).

2. The information in this chapter is intended to assist in the interpretation of the Planned Bay Servicing Schedule. It is most important that any attempt to carry out planned bay servicing should be made in accordance with the instructions laid down in Vol. 4, Part 6.

DISMANTLING AND GENERAL SERVICING NOTES

Receiver Type R.4187

3. The receiver consists of the main chassis assembly Type 4211 on which is mounted the RF unit (amplifying unit Type 4207-10U/16831) and the IF unit (amplifying unit Type 4208-10U/16832). The rotary transformer unit (power unit Type 4231-10K/17986), its associated filter unit Type 4236 (10P/16066) and the selector unit Type 4230 (10D/19085) are all listed as part of the chassis assembly. The power unit can be removed as a separate sub-chassis after the removal of fixing screws (*para.* 8).

4. The RF and IF units may be removed as follows:—

- (1) Remove the dust cover from the receiver after releasing the two Oddie fasteners at the rear of the chassis.
- (2) Remove the countersunk screws at the rear of the RF and IF units (two in each chassis).

(3) Remove the yellow and green coaxial plugs from the IF unit.

(4) Remove the black, yellow, red and green plugs from the RF unit and slacken the brackets on top of the coil cans to release the leads as required.

(5) Loosen the two cleats holding the leads of the four coloured plugs.

(6) Lift the rear end of the RF unit by the handle and release the tuning drive wire from the pulley on the capacitor drive.

(7) To remove the RF and IF units, lift each chassis by the handle at the rear to disengage the plugs and sockets between the units and the main chassis.

5. *Dial lamp PL2.* When it is required to replace the receiver tuning dial lamp it is first necessary to remove the RF unit.

6. *Air filter.* To remove the input filter of the forced-air cooling system, release the two Oddie fasteners at the base of the filter cover. The cover and filter can then be removed as one. The filter is attached to the cover by two captive screws.

7. The filter can then be cleaned by a gentle tapping to shake out the dust. The filter surface should not be brushed, as this tends to drive the dust into the surface. When fitting the filter, take care to insert it the correct way round as indicated by the arrow on the filter.

RESTRICTED

Power unit

8. To remove the power unit, turn the receiver chassis upside down and remove the input leads from the terminal connection marked "G". Slacken the four captive 4BA red screws at the base of the rotary transformer and withdraw the unit from the underside of the main chassis.

9. To uncover the filter unit of the rotary transformer, remove the four 6BA red screws from the filter cover. The filter cover, of course, can be removed with the power unit in situ.

Selector unit Type 4230

10. With the RF and IF units removed, the channel selector motor becomes accessible together with the gears on the spindles of the 12-way potentiometers; these gear wheels must be removed before withdrawing the potentiometers from the selector unit.

11. When replacing the potentiometers, select channel M on the receiver, set the potentiometers to the mid-traverse of channel M, and replace. Before securing the gear wheels, ascertain that the potentiometers are still at the centre of the traverse on channel M.

Adjustment of gears of RF unit mechanical drive unit

12. For use in the event of complete dismantling or indication of mis-adjustment of gears (bottoming and slipping), the main coupling shaft is fitted with ball-races mounted in eccentric holders allowing vertical adjustment of 0.01 in. The holders can be secured in any one of six positions.

Clicker switch SIG on main chassis assembly

13. The rotor of the clicker switch is mounted on the shaft of switch S1. The rotor must be adjusted so that when the switch wafers of SW1 are central between the jaws of the contacts the vertical (trailing) edge of the spring set follower must be 0.062 in. from the edge of the notch in which it has fallen, and the contacts closed. When the follower is riding over an abutment, the distance between the contacts should be 0.03 in.

Control unit Type 4190

14. Control unit Type 4190 consists of oscillator unit Type 4215 (10V/16258), motor unit Type 4214 (10K/17989), panel (control) Type 7246 (10D/19245) and relay unit Type 4216 (10F/17704).

15. The dust cover (cover Type 898-10AP/228) can be removed after unlocking one Oddie fastener at the rear of the chassis.

16. *Crystal oscillator unit.* To remove the oscillator unit Type 4215, pull out socket SK3 and plug PL9 (it may also be necessary to pull out the socket SK2 as the associated lead causes obstruction). Remove the four red retaining screws on top of the chassis and lift out the oscillator.

Resistor unit Type 4217

17. Potentiometers POT.1 and POT.2 The potentiometers are a sub-assembly of the front panel equipment known as panel (control) Type 7246.

18. Remove the cover over the potentiometers and switches. (10D/19245). The potentiometers can be removed "through" the front panel after taking out two screws from the front and pulling out socket SK2 on top of the chassis. The potentiometer mounting is then pulled through the front panel.

Panel (control) Type 7246 (10D/19245)

19. To separate the panel from the main chassis use the following procedure:—

- (1) Remove the cover from the potentiometers POT.1 and POT.2.
- (2) Take out the four "long-headed" screws in the lower half of the front panel. These are located two in the bottom corners of the panel and two at the sides of the panel just below the air filter covers.
- (3) Remove the long screws and spacers from the two top corners of the front panel.
- (4) Pull out the front panel handle to separate the panel (control) Type 7246 from the main chassis.

Motor unit Type 4214

20. Remove the selector motor securing clamp.

21. Remove the selector motor back plate and disconnect the supply leads.

Note . . .

The selector and tuning motor are designed to rotate in either a clockwise or counter-clockwise direction. To ensure correct connection on replacement, the position of the connecting leads to the motor should be carefully noted before removal.

TRANSMITTER TYPE T.4188

Dismantling

22. The three main units which together make up the transmitter can be rapidly separated with the aid of a screwdriver. All connections between them are made by plugs and sockets. The main units are the chassis assembly Type 4210 (10D/19076), drive unit, mechanical Type 4212 (10AR/2218) and tuning unit Type 4218 (10D/19078).

23. The transmitter dust cover (cover Type 896-10AP/226) can be removed after unlocking the Dzus fastener at the rear of the unit.

Tuning unit covers

24. Three screening cans are fitted to the tuning unit Type 4218 (10D/19078) and these can be easily removed by taking out fixing screws as follows:—

- (1) Cover Type 1009 (10AP/239). Remove four screws from the rectangular top. Remove two screws from the bracket (marked red) near the top of the can. Remove one screw from a bracket at the base of the can. Through the aperture in the top of the can, depress the terminal holding the top cap connection to the P.A. valves and remove the connection (TS.8). Lift the cover off.

RESTRICTED

- (2) Cover Type 1007 (10AP/237). Remove two screws from the square top. Remove the screw from the bracket (coloured red) near the top of the can. Remove one screw from a bracket at the base of the can. Through the aperture in the top of the can, depress the terminal (TS.3) holding the top cap connection to V2 and remove the connection. Lift the cover off.
- (3) Cover Type 1008 (10AP/238). Remove the two screws from the square top. Remove one screw from a bracket at the base of the can. Lift the cover off.

Chassis assembly Type 4210

25. To remove the screening cover on the underside of the chassis assembly it is necessary to release the Dzus fasteners, one on the underside and three at the side of the chassis. The cover must be manoeuvred sideways before lifting off to clear the fastener nearest the front panel.

26. The spring top cap assembly of the P.A. valves (V3 and V4) can be removed by first removing the top cap connection to the terminal TS8 and then undoing the two 4BA nuts near the centre of the assembly. The assembly can be removed from the valves, but is still connected to the porcelain terminal post at the junction of the chokes L10 and L11.

27. *Removal of P.A. valves mounting assembly.* The complete mounting can be separated from the main chassis after removing the following:—

- (1) The spring top cap assembly (*para.* 26).
- (2) Four red screws located on the underside of the chassis.
- (3) One red screw located behind the air filter; the air filter must be removed from the housing to give access to this screw. The filter is held in position by the pressure of two 6BA screws which pass through the top of the filter housing. Slacken the screws and remove the filter with the fingers. (Be sure to replace the filter the correct side in as indicated by arrows.)

28. *Removal of the blower motor assembly MG2.* Unsolder the connection to the electrical filter input. Remove the three red screws on the blower assembly base mounting (underside of chassis).

29. *Removing the filter housing for accessibility to the P.A. valve bases and associated components.* Remove the red screws inside the filter housing (*para.* 27). Remove two red screws on the filter housing base (underside of chassis). Remove the two screws marked red securing the cover Type 1009 to the filter housing.

30. *Removal of the tuning unit.* The tuning unit can be separated from the main chassis assembly

by the removal of four screws marked red. The flexible drive unit Type 31 (10AR/461—endless chain) must be removed from the coil driving spindle before the tuning unit is released. The chain hook is used for removing the chain.

Note . . .

A long-shanked screwdriver is required to release the bolts holding this unit to the valve unit casting. Care should be taken with the rear bolt to avoid damage to adjacent capacitors. When replacing the unit, great care should be taken to ensure correct ganging between the drive unit and the coils.

31. Removal of the mechanical drive unit. The drive unit can be separated from the remainder of the chassis as follows:—

- (1) Remove the front panel control knobs and the carrying handle.
- (2) Remove the four red screws on the underside of the main chassis assembly.
- (3) Remove the two red screws from the bracket at the top of the relay panel on the top of the chassis.
- (4) Remove the endless chain from the mechanical drive unit to the tuning unit with the aid of the chain hook (*para.* 28).
- (5) When replacing the drive unit, set the coil unit so that the contact brushes are at the calibration mark on the last turn of the coils (top end) when the drive unit is set to the HF limit mark.

Removing the blower motor

32. To remove the blower motor, first remove the base cover from the transmitter unit. Release the soldered connections at the filter X2 (the connections are long enough to allow inspection without detaching these leads).

33. Remove the three red securing screws and lift the motor assembly clear. Remove the fan cover, fan and fan housing.

Power and radio unit Type 4192

34. The power and radio unit consists of the transmitter power unit (HT) and the modulator unit; the power unit includes the rotary transformer and filter unit.

35. *Cover Type 889.* Remove the dust cover after releasing the Oddie fastener at the rear of the unit.

Modulator unit

36. The modulator unit is known as the amplifying unit Type 4209 (10U/16833) which will be superseded by amplifying unit Type 7435 (10U/16659). It is mounted on a sub-chassis which can be removed from the main chassis after unfastening four red captive screws.

RESTRICTED

37. Before lifting the sub-chassis from the main chassis, remove the coaxial plug PL4 and the multipole socket SK6. To avoid damage to the modulator valves, remove the top cap assemblies and take out the valve V6 and V8 before lifting out the unit.

Note . . .

Socket SK6 can only be removed when its locking catches are depressed. These are mounted on each side of the socket body.

Filter unit Type 4213

38. To examine the rotary transformer filter unit, lift off the cover Type 1006 (10AP/236) after removing the remaining screw.

Power unit

39. The power unit can be removed by releasing the two metal circlips around the body of the machine. The electrical connections of the rotary transformer are on the underside of the chassis in the filter unit Type 4213 (*para.* 46). Remove the base cover, slacken the connector screws and disconnect the leads to the power unit rotary transformer. Release the bridge mounting of heater resistor R41 and hinge to the left. Remove the power unit.

40. To inspect the brushes with the power unit in situ, remove the air filters (*para.* 39) and the plate behind them. The LT brushes and cowl can now be removed through the filter housing. The HT brushes can be inspected by releasing the rear bridge mounting.

41. Air filter. Access to the filters of the forced-air cooling system is from the front of the power and radio unit. The air filter cover can be removed after releasing two Oddie fasteners.

42. Spare fuses. Access to spare fuses for F1, F2 and F5 is behind the air filters, i.e. the filters must be removed.

◀ **Relay, magnetic Type 1536 (RL1/3—Transmitter Type T.4188)**

43. The following instructions concerning the setting-up of relay, magnetic Type 1536 (10F/17593) have been issued by the Design Authority.

- (1) Push armature fully in and check that the movement is "free."
- (2) With armature fully operated check:—
 - (a) Gap of economy contact is .020—.025 in.
 - (b) Main contacts are closed and that a pressure of at least 50 grams is required to lift each fixed contact from its opposite moving contact.
 - (c) The armature is bottoming against the internal step and not on the flange at economy contact end.
- (3) With the armature released check that there is at least $\frac{1}{8}$ in. gap in main contacts.
- (4) Push the armature and observe main contacts; after closing and before armature is fully operated, there should be a slight wiping action.
- (5) Apply 19 volts DC between frame and coil, i.e., the two outer tags on solenoid. The relay will operate fully with no continuous arcing at the economy contact. Note, there will be momentary arcing when the contacts break.
- (6) Apply 30 volts DC. The relay will operate satisfactorily.
- (7) If the relays are set up accurately, they will operate satisfactorily with a voltage as low as 12 volts. ▶

RESTRICTED

Chapter 3

GENERAL SERVICING OF SUPPRESSED AERIAL EQUIPMENT

LIST OF CONTENTS

	Para.		Para.
<i>Introduction</i>	1	<i>Tuning units (aerial) Type 7015 and 7016</i>	8
<i>Dismantling and general servicing notes</i>		<i>Drive unit, mechanical, Type 7220</i>	10
<i>Control unit Type 7216</i>	3	<i>Selector unit Type 7003</i>	13
<i>Impedance matching units Type 7217 and 7949</i>	6	<i>Relay unit Type 7332</i>	14
		<i>Drive unit, mechanical, Type 7333</i>	16

INTRODUCTION

1. First and second line servicing information on the suppressed aerial equipment is given in the form of servicing schedules in Volume 4, Parts 2, 3, 4 and 6 of this Air Publication. For information on third line servicing reference should be made to Volume 6 (limited distribution).

2. The information in this chapter is concerned mainly with dismantling and refitting. It is most important that any attempt to carry out planned bay servicing should be made in accordance with the instructions laid down in Vol. 4, Part 6.

DISMANTLING AND GENERAL SERVICING NOTES

Control unit Type 7216

3. For inspection purposes it is necessary only to take off the cover after removal of four nuts at the rear of the control unit.

4. If it is required to remove the SAFE lamp, first check that modification No. 3898 has been carried out. This describes the incorporation of a new type of SAFE lampholder which reduces the length of time required for renewal of the lamp. This modification can be associated with modification No. 3451 which entails the fitment of a series resistor with the lamp. The modifications are described in Vol. 2 of this A.P.

5. After inspection and servicing replace the cover and the four securing nuts.

Impedance matching units Type 7217 and 7949

6. The details for dismantling the impedance matching units are similar for each Type. The following description applies to impedance match-

ing unit Type 7217; the differences for Type 7949 will be obvious. (*Sect. 2, Chap. 4 and 7.*)

(1) Using a 4 B.A. spanner, remove the two aerial coupling plugs and the retaining nut.

(2) Remove the circular paxolin cover.

(3) Remove two countersunk screws from the contact wiper arm.

Note . . .

Position of wiper arm is to be noted to ensure correct replacement.

(4) Remove contact wiper.

(5) Remove four 4 B.A. nuts retaining the mounting plate to spacers.

(6) Remove the 4 B.A. nut from the large contact segment.

(7) Remove the switch housing.

(8) The matching coil and switching unit may be examined.

(9) Replace the switch housing and four 4 B.A. retaining nuts.

(10) Refit 4 B.A. nut connecting the coil to the large contact segment.

(11) Replace the wiper arm in the position noted on removal and tighten the securing screws.

RESTRICTED

- (12) Replace the circular paxolin cover.
- (13) Refit two aerial coupling plugs and retaining nuts.

7. If it is required to remove the drive motor proceed as follows:—

Note . . .

The motor is designed to rotate in either a clockwise or counter-clockwise direction. To ensure correct connection on replacement, the position of the connecting leads to the motor should be noted before removal.

- (1) Remove three securing nuts from motor housing cover.
- (2) Remove the motor housing cover.
- (3) Remove two screws retaining the motor to mounting plate.
- (4) Withdraw the motor, remove the backplate and disconnect the supply leads.
- (5) Remove the drive gear from the motor.
- (6) Fit the drive gear to the serviced motor and remove the backplate.
- (7) Connect the supply leads to the serviced motor and refit backplate.
- (8) Position on mounting and secure with two retaining screws.
- (9) Check that the motor gearing is meshed correctly.
- (10) Refit the motor housing cover and secure with three retaining nuts.

Tuning units (aerial) Type 7015 and 7016

8. The following dismantling details are for the tuning unit (aerial) Type 7015. Details for the Type 7016 are almost identical. (Sect. 2, Chap. 3 and 6.)

9. First release the pressure from the unit by means of the Schrader valve, and then carry out the following instructions:—

- (1) Release the screw and latch of the circular clamp and remove.
- (2) Tap the insulator end cover with the hand to break the seal.
- (3) Remove cover and sealing ring.
- (4) Stow end cover and sealing ring.
- (5) Using 2 B.A. box spanner or suitable screw-driver, turn special gear by the side of the bellows switch unit clockwise until capacitor vanes are fully meshed.
- (6) Remove the red-headed screws securing the socket SK-4 to plug PL-A and remove socket.

- (7) Remove three hexagonal bolts marked with red circle. Withdraw unit from the canister with extreme care.

- (8) Remove protective paxolin cover inside the canister by removing the securing screw.

- (9) Refit the paxolin cover and securing screw.

- (10) Remove the end cover 2 B.A. securing nut.

- (11) Withdraw cover carefully to expose the internal wiring.

Drive unit, mechanical, Type 7220

10. To remove the drive unit assembly use the following procedure:—

- (1) Remove the 4 B.A. nut securing the input lead to the busbar.

- (2) Remove three 4 B.A. nuts coloured red which secure the drive unit casting to the capacitor assembly.

- (3) Carefully withdraw the drive unit complete with cam-shaft, ensuring that the pressure spring on the end of the cam is not lost.

Note . . .

Extreme care is to be taken to ensure that the cam-shaft is not damaged in the process of removal.

11. For examination of the motor proceed as follows:—

- (1) Remove backplate from motor and disconnect supply leads. (See Note to para. 7.)

- (2) Remove two countersunk 6 B.A. screws securing the motor to the casting.

- (3) Remove motor from housing and disconnect the drive gear.

- (4) Return motor for Third Line Servicing.

- (5) Fit drive gear to serviced motor and remove backplate.

- (6) Refit serviceable motor, connect supply leads and refit backplate.

12. To refit the drive unit assembly, proceed as follows:—

- (1) Engage the securing studs of the casting with capacitor and plate.

- (2) Depress the capacitor spring sets to allow the free end of the cam-shaft to enter bearing, ensuring pressure spring and washer are in place.

- (3) Press the drive unit home, engaging socket SK-B to plug PL-B.

- (4) Refit the securing nuts.

RESTRICTED

- (5) Reconnect the input lead to the busbar.

Selector unit Type 7003

13. The dust cover can be removed from the selector unit after releasing two Dzuz fasteners at the rear of the unit.

Relay unit Type 7332

14. The following instructions are for removal of the relay unit Type 7332.

- (1) Remove red-headed screws securing the socket SK-B to plug PL-B and SK-C to PL-C.
- (2) Disconnect the plugs from the sockets.
- (3) Remove four red-headed screws securing the unit to the main chassis.
- (4) Tilt the unit and remove.

15. The following operations are to be carried out only if the rubber tension is slack.

- (1) Loosen two 6 B.A. screws securing the block (nearest to the relay bank).
- (2) Move the block towards the relay bank until the rubber is just in tension and tighten the block securing screws.

Drive unit, mechanical, Type 7333

16. To remove the drive unit, mechanical, Type 7333 carry out the following instructions.

- (1) Remove eight 6 B.A. countersunk screws securing the backplate to the main chassis.
- (2) Remove the red-headed screw securing the socket SK-A to plug PL-A and remove the socket.
- (3) Fold backplate around left-hand side of the main chassis.
- (4) Remove four red-headed screws securing the drive unit to the main chassis.
- (5) Lift slightly to disengage the unit from insulating bushes, and withdraw unit.

17. If it is required to remove the drive motor (Vol. 4, Part 6) proceed as follows:—

- (1) Remove the backplate of the motor and disconnect the supply leads.

Note . . .

The motor is designed to rotate in either a clockwise or counter-clockwise direction. To ensure correct connection on replacement the position of the connecting leads to the motor should be noted before removal.

- (2) Remove the two screws securing the motor to the drive unit.
- (3) Refit a serviceable motor, reconnect the supply leads and refit the backplate.

18. Refit the drive unit assembly as follows:—

- (1) Ensure that the insulating bushes on the main chassis are in position.
 - (2) Slide the drive unit on to the main chassis, aligning the turret to engage the drive spindles.
 - (3) Check that the insulating bushes have not been displaced.
 - (4) Refit securing screws, but do not tighten.
 - (5) Ensure that there is no undue end play between turret and drive unit.
 - (6) Set the turret contacts in mesh with the resistor-to-drive-unit end, and tighten securing screws.
 - (7) Using screwdriver, turn preset tuning through full travel and ensure contact makes good electrical contact along the full length of the resistor.
 - (8) Refit socket SK-A to plug PL-A and refit securing screws.
 - (9) Reposition backplate on to main chassis and refit securing screws.
- 19.** Refit the relay unit type 7332 as follows:—
- (1) Position the relay unit on the main chassis and secure with four screws.
 - (2) Refit socket SK-B and PL-B and SK-C to PL-C and refit the securing screws.

RESTRICTED

Chapter 4

GENERAL SERVICING OF FIXED AERIAL EQUIPMENT

LIST OF CONTENTS

	Para.		Para.
<i>Introduction</i>	1	<i>Dismantling and general servicing notes— Aerial tuning unit Type 7180</i>	
<i>Dismantling and general servicing notes— control unit Type 4243</i>		<i>Removing a motor</i>	24
<i>Front panel</i>	3	<i>Drive unit, mechanical, Type 7510</i>	25
<i>Fault location</i>	13	<i>Fault location</i>	27
		<i>Mechanical adjustment</i>	28

INTRODUCTION

1. First and second line servicing information on the fixed aerial equipment is given in the form of servicing schedules in Volume 4, Parts 2, 3, 4 and 6 of this Air Publication. For information on third line servicing reference should be made to Volume 6 (limited distribution).

2. The information in this Chapter is intended to assist in the interpretation of the Planned Bay Servicing Schedule. It is most important that any attempt to carry out planned bay servicing should be made in accordance with the instructions laid down in Vol. 4, Part 6.

DISMANTLING AND GENERAL SERVICING NOTES—CONTROL UNIT TYPE 4243

Front panel

3. The switches and connections at the rear of the front panel are readily accessible and fault location can generally be effected without complete dismantling. Should it be found necessary to remove the front panel, proceed as follows:—

- (1) Remove switch and key knobs.
- (2) Remove the potentiometer unit as described in para. 4.
- (3) Remove four special stud screws showing through the panel.
- (4) Remove two long screws located each side at the top of the panel. A soldering iron is not required since all the connections are taken through plug PL10 and socket SK5.

Removal of potentiometer unit (resistor unit Type 7532)

4. Remove the front cover from the potentiometer unit and then take out the two round-headed screws, one on each of the lugs at the sides of the panel.

5. Remove the 18-way plug PL2 from the socket SK2 (close to the oscillator chassis). The potentiometer unit can now be gently eased forward to

enable the spring bush carrying the idler gear (to the rear of POT 6—"2 SERIES") to be disengaged from the side of the unit by means of a screwdriver.

6. Gently withdraw all the potentiometers through the front panel. It should be noted that the removal of this unit gives added access to the band switches.

Removal of 12-way potentiometer from the main unit

7. Loosen the grub screw on the gear situated at the rear of the particular potentiometer and remove the gear wheel. With pliers withdraw the bush retaining spring located behind this gear and push out the spindle bush. Unsolder the connection carefully from the tag strip (noting the position of the wires for re-assembly). Remove the four pillar screws at the front of the potentiometer, this may now be pushed backwards to allow the twelve knobs to pass through the front panel.

Removal of oscillator unit Type 4215

8. Release the four holding screws on socket SK4 and disengage the socket from the chassis. Withdraw the coaxial plug PL8 from the socket SK3.

9. Unscrew the four red-painted screws on the top of the oscillator chassis and lift the oscillator clear of the chassis. (It may be necessary to remove one or more of the valves to ensure the necessary clearance for removal of the chassis).

Removal of rear panel

10. Remove the twelve countersunk screws placed at intervals around the panel at the rear of the chassis. Ensure that the coaxial lead and socket connected to plug PL4 is free. The rear panel can now be hinged down to permit the removal of relay unit Type 4216.

Removal of selector switches

11. Remove the retaining nuts at the two mounting pillars of the selector switches (S3A to S3H); then by carefully demounting the spacers, each switch can be withdrawn over the shaft, easing the

RESTRICTED

cable form as this is done. The faulty switch or contact bridge can then be renewed and the switches reassembled.

12. With the selector switches removed, the forward bearing of the selector shaft can also be removed to allow the removal of the "clicker" cam and access to the motor gearing.

Fault location

13. Fault location on the control unit Type 4243 is mainly confined to DC point-to-point testing. It should be noted that when the unit is in the "off" condition, several relays are released when compared with the "rest" condition of STD/BY and thus paths to earth (etc.) are not complete. A "listening rod" applied to relays is a useful check to their operation. (This can be any suitable rod which can be held to the ear at one end and pressed against the required relay at the other end.)

14. The following possible faults are listed under appropriate headings. It is assumed that the control unit Type 4243 is interconnected with all the units necessary to make up a complete fixed aerial installation (such as the test bench rig).

Motor will not operate—tight gearing

15. This will probably be caused by the motor worm drive being overmeshed. It may also be due to lack of oil on the bearings, particularly on the potentiometer spindles of the resistor unit Type 7532.

Selector motor runs continuously

16. This may be due to one or both of the following faults:—

- (1) To incorrect adjustment of the clicker switch S3J (the adjustment of this is described in *para.* 19).
- (2) Faulty switch section S3C or faulty wiring between S3C and its counterpart S1A in the receiver.

Selector motor will not start

17. If the selector motor will not start when the channel selection switch on the remote control unit is moved and the receiver unit has finished selecting, it may be due to one or more of the following faults:—

- (1) Faulty relay RL1.
- (2) Faulty selector motor MG1.
- (3) Fuse 3F2 blown in power and modulator unit.
- (4) Faulty switch section S3C in control unit Type 4243.
- (5) Faulty switch section S1A in receiver.
- (6) Open-circuit in wiring between S3C control unit Type 4243 and S1A in the receiver.
- (7) Loss of 28V supply to relay RL1.

Note . . .

When a fault is peculiar to one channel or one tuning band it can usually be traced from the appropriate circuit.

Overheating of 12-way potentiometer winding

18. A permanent earth on the wiper of the potentiometer, i.e. the inner mounting frame, will cause the winding to over-heat or burn out.

Adjustment of "clicker" switch S3J

19. When a wiper on S3A or S3B is in the centre of one of the 12 contacts, there should be 0.062 in. between the "vertical" face of the follower of the spring set and the edge of the notch of the cam into which it has fallen.

20. When the follower is raised to the maximum diameter of the cam, the contacts of the spring set must be separated by 0.030 in. ± 0.007 in.

21. When S3J is properly adjusted and the gearing is running smoothly (*para.* 22) the stopping sequence should operate satisfactorily with:—

- (1) The 19V supply increased to 22V, with the 28V supply normal.
- (2) The 19V supply normal and the 28V supply reduced to 22V. The potentiometer unit is in position for this test.

Check on freedom of gearing

22. With the potentiometer assembly removed, the application of 6V to the selector motor should turn the gearing freely.

23. With the potentiometer unit in position, the gearing should turn smoothly with 12V applied to the selector motor.

DISMANTLING AND GENERAL SERVICING NOTES—AERIAL TUNING UNIT TYPE 7180

Removing a motor

24. Take off the dust cover of the aerial tuning unit. Turn the switch S1 to MAN; invert the chassis and remove the tension springs from the motor cradle. Remove the lock-screw from the cradle back-plate and unscrew the back-plate to expose the rear plate of the motor. Remove the plate, disconnect the motor and lift it clear of the chassis.

Drive unit, mechanical, Type 7510

25. Access to the drive unit mechanical can be obtained by removal of the front panel. This panel can be released by removal of two screws after the knobs and carrying handle have been detached.

26. Complete removal of the drive unit is not recommended owing to the electrical wiring involved; however, with the front panel removed adjustments and renewal can be carried out by release and removal of the affected spindles and gear wheels.

Fault location

27. The location of electrical faults on the aerial tuning unit is described in Part 3, Chap. 1.

RESTRICTED

Mechanical adjustment**Note . . .**

The following figures are given for guidance only. For servicing reference must be made to Vol. 4, Part 6.

28. Coils. At the high frequency "limit-stop" the distance from the end of the coil winding to the centre of the contact is $\frac{5}{8}$ in.

29. The contact pressure should be 250-350 gram. measured on the contact bar adjacent to the contact.

30. When cleaning, use the recommended spirit cleaner and polish with dry lint-free cloth.

31. Drive unit. At extreme band limits the resistance between the potentiometer slider and adjacent end of the stator should be 5.5 ± 0.5 ohms. If this cannot be attained the potentiometer should be set for equal readings at each end of the band.

32. With the switch S1 in the MAN position, the worm drive on the motor shafts should clear the worm wheels by at least 0.07 in. Adjustment can

be carried out by means of the motor link rods at the rear end of the motor cradles.

33. With the switch S1 in the AUTO position the motor tension, at the spring fixing, should be as follows:—

MG1 1200-1300 gram.

MG2 1500-1800 „

MG3 1500-1800 „

34. When S1 is set at AUTO the tapered "motor stops" are used to prevent the gears "bottoming"; these should not require adjustment. Indications that adjustment is required are that the affected motor is noisy with signs of wear on the gears.

35. The clutch is adjusted to slip at 3250-4000 gram/cm.

36. If the motor is made to drive past the band limit (28V to motor) the clutch must slip without the motor jumping on the worm wheel. It may be necessary to increase the tension on the motor springs.

RESTRICTED

Chapter 5

SPECIAL TEST EQUIPMENT

LIST OF CONTENTS

	Para.		Para.
Introduction	1	Test rig installation, Type 7470	13
Indicator output (RF-70 ohms), Type 7712	3	Test rig installation, Type 7471	16
Circuit description	5	Test rig installation, Type 7472	17
Dummy load, Type 7771	8	Socket, Type 704 (modified)	18
Circuit description	11	Test meter (current), Type 7626	21
Test rig installations	12		

LIST OF TABLES

	Table
Special test equipment for 2nd line servicing	1
Items for test meter (current), Type 7626	2

LIST OF ILLUSTRATIONS

	Fig.		Fig.
Indicator output (RF-70 ohms), Type 7712	1	Dummy load, Type 7771—circuit	4
Indicator output (RF-70 ohms), Type 7712—circuit	2	Socket, Type 704—modified	5
Dummy load, Type 7771	3		

Introduction

1. The special test equipment described in this chapter is for use on 2nd line servicing of ARI.5874. It does not include the special items for 3rd line servicing which are described in Vol. 6 (limited distribution), although it can be assumed that most of the test equipment (listed in *para.* 2) will also be used on 3rd line.

2. A complete list of test equipment required for 2nd line servicing bays is given in Chapter 1. The following special test equipment is included in that list.

TABLE I

Special Test equipment for 2nd line Servicing

(1)	10S/16771	Indicator, output (RF-70 ohms), Type 7712
(2)	10S/16773	Dummy load (RF), Type 7771
(3)	10S/16494	Test rig installation, Type 7470
(4)	10S/16495	Test rig installation, Type 7471
(5)	10S/16496	Test rig installation, Type 7472
(6)	10HZ/19611	Socket, Type 704
(7)	10S/16752	Test meter (current), Type 7626

Note . . .

For fixed wire aerial installations items 1, 2, 3, 5, 6 and 7 are required.

For suppressed aerial installations items 1, 3, 4, 6 and 7 are required.

Indicator output (RF -70 ohms), Type 7712

3. A general view of the output indicator is given in fig. 1. The circuit includes the following items:—

- (1) Thermoammeter 0–2 amp. 5Q/25317
- (2) Resistors Type 10620 (6 off).
These are 420-ohm 28-watt resistors, fixed wirewound and non-inductive 10W/19886
- (3) Plug fixed, coaxial, single-pole, panel mounting Z/540101
- (4) Capacitor, fixed, ceramic 4.7pF, 500V DC working Z/132251

4. From fig. 1 it can be seen that the ammeter is mounted on the front panel; the 28-watt resistors are carefully enclosed inside the case. Access to the resistors is gained by removal of four screws holding the back of the case. The coaxial plug PL1 and the REST terminal are brought out to the left-hand side of the indicator. Ventilation is provided by numerous holes in the case of the instrument.

Important Note . .

The indicator output Type 7712 (0–2 amp) is very similar in appearance to indicator output Type 7150 (0–1 amp). To avoid erroneous use of the Type

RESTRICTED

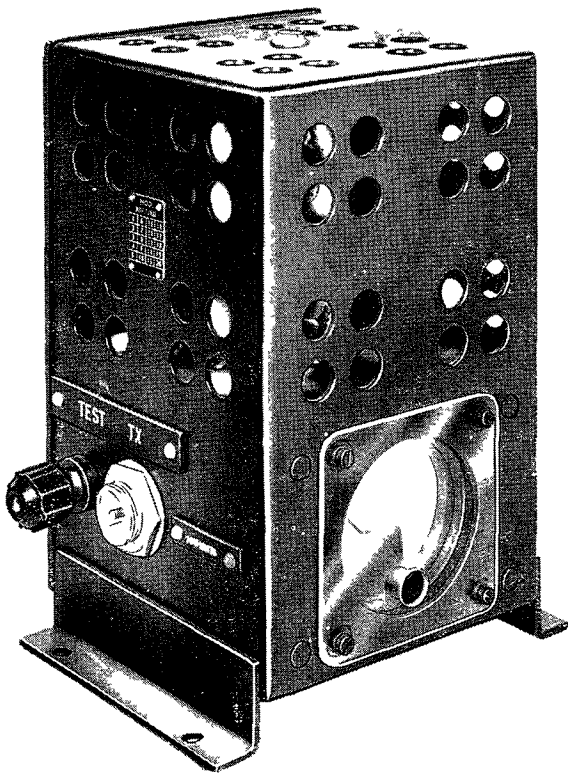

Fig. 1. Indicator output (RF-70 ohms), Type 7712

7150, the coaxial plug of each indicator is marked as follows:—

10S/16771	Type 7712	(100W)
10S/16760	Type 7150	(50W)

Those carrying out tests should, of course, look for the 100W marking when connecting up.

Circuit description

5. The circuit is shown in fig. 2. Six 420-ohm wirewound resistors R1a to R1f are connected in parallel, affording a total power dissipation of 168 watts and an impedance of 70 ohms. The resistors are connected in series with a 0.2 amp. thermoammeter and the coaxial plug PL1. The other end of the paralleled resistors is connected to chassis (earth).

6. The input to the indicator is from the transmitter output via the control and drive unit plug 1AG to 16AG. The connection is made to PL1 (marked 16AG, 100 watts) on the RF output indicator.

7. For other test purposes, such as waveform checks on 2nd line servicing, a test terminal is provided. This is connected to the input side of the meter via a 4.7 pF capacitor. If terminal A of the oscilloscope Type 13A is connected to this terminal (TEST) the waveform of the transmitter output can be checked for conditions of CW and R/T.

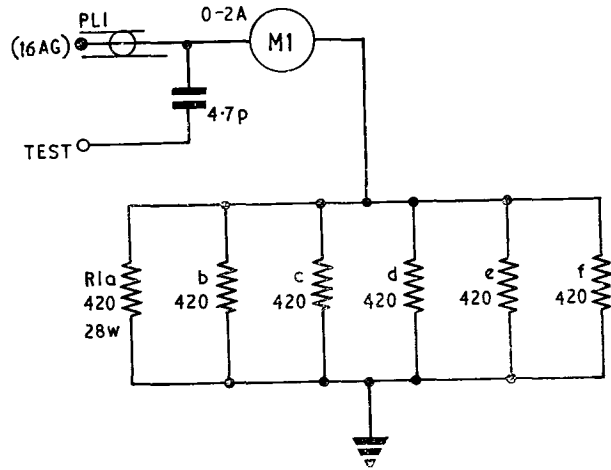

Fig. 2. Indicator output (RF-70 ohms), Type 7712—circuit

Dummy load, Type 7771

8. Dummy load Type 7771 is required for testing the tuning unit (aerial) in fixed wire aerial installations. A front panel view is given in fig. 3. The load is switched within the HF band as follows:—

- Band 1. 2.8 to 8 Mc/s
- Band 2. 8 to 11.5 Mc/s
- Band 3. 11.5 to 14.5 Mc/s
- Band 4. 14.5 to 18 Mc/s

9. The four circuits include the following main components:—

- (1) Capacitor, Type 7099, 100pF, 10 kV (C1) 10C/20882
- (2) Capacitor, Type 6562, 125pF, 10 kV (C2) 10C/19320
- (3) Capacitor, Type 6563, 100pF, 10 kV (C3) 10C/19321
- (4) Inductor, Type 1821, 12μH, 30 turns (L1) 10C/18955
- (5) Inductor, Type 1819, 2.6μH, 10½ turns (L2) 10C/18953
- (6) Inductor, Type 1820, 0.9μH, 4 turns (L3) 10C/18954

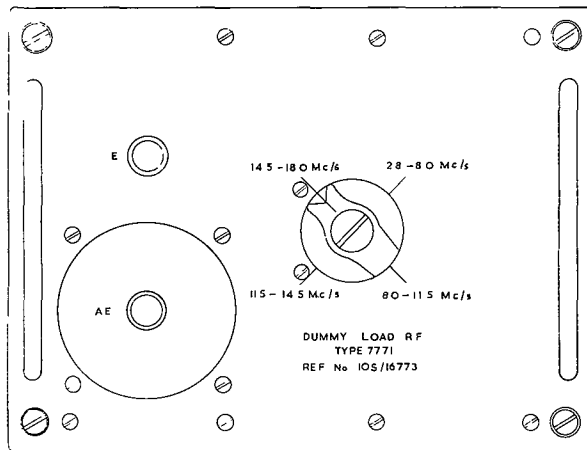

Fig. 3. Dummy load, Type 7771

- (7) Resistors, Type 6273,
20 ohms, 25W (R5-R8) 10W/6273
- (8) Resistors, Type 177,
100 ohms, 25W (R1-R4) 10W/8675

10. Mounted on the front panel is the continuously rotatable manual range switch with four positions as indicated in para. 11. This is the only control on the panel, the other features being the two insulated terminals for aerial and earth connections.

Circuit description

11. A circuit diagram is given in fig. 4. The 4-way switch selects the load components for each band as follows:—

- Band 1. C1, L1 and the paralleled resistors R1 to R4.
- Band 2. L2 in parallel with C2 and the paralleled resistors R5 to R8 (C2 and the resistors being in series).
- Band 3. Here the load consists of the paralleled resistors R1 to R4 only.

Band 4. L3 in parallel with C3 and the paralleled resistors R5 to R8 (C3 and the resistors being in series).

Test rig installations

12. The test rig installations, Type 7470, 7471 and 7472 are supplementary installations to the test bench rig described in Chapter 1. Test rig installation, Type 7470 may be used alone (as part of the test bench rig) for testing the transmitter-receiver items of ARI.5874, or in conjunction with test rig installation, Type 7471 (for testing suppressed aerial items in a complete installation—ARI.5874), or in conjunction with test rig installation 7472 (for testing fixed aerial items in a complete installation—ARI.5874).

Test rig installation, Type 7470

13. This test rig consists of a number of special rack mountings for items of the transmitter-receiver equipment with the associated back-plate fixing for each item. With these back-plates and

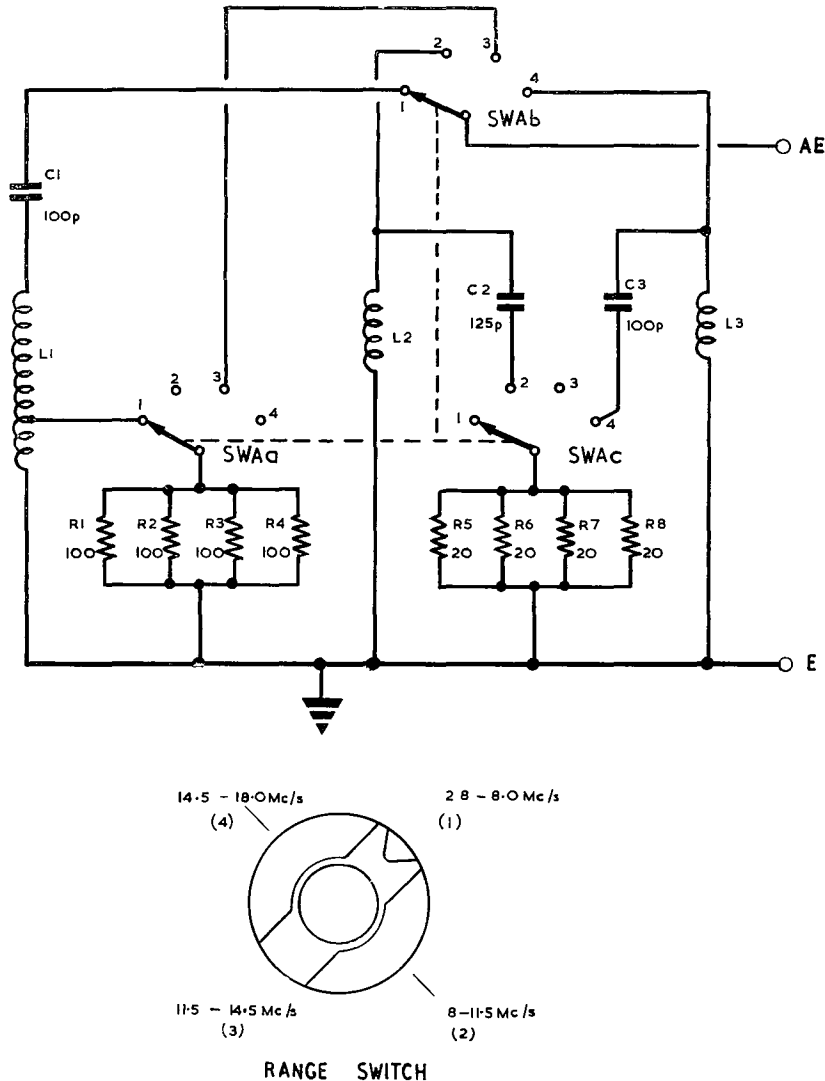

Fig. 4. Dummy load, Type 771—circuit

RESTRICTED

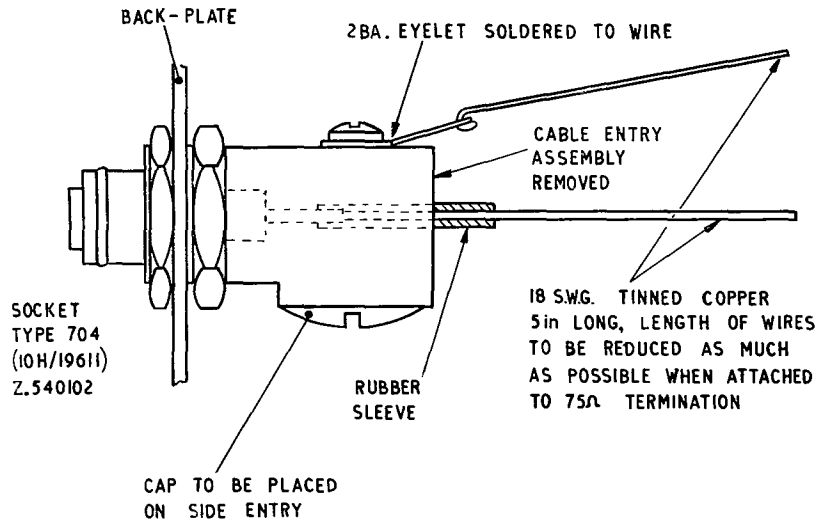

Fig. 5. Socket, Type 704—modified

mountings is supplied a complete set of connectors for interconnection of the units as an installation without an aerial system. The connectors are described as "connector set for test rig installation, Type 7470," and are listed in Chapter 1.

14. A list of items other than the associated connector set follows:—

- (1) *Mounting, Type 7667 (10AJ/235)*. This is an aluminium and steel fabricated mounting of the rack type for the voltage regulator Type 5UC/6010 and includes a backplate 5UC/6011.
- (2) *Mounting, Type 7668 (10AJ/236)*. This is an aluminium and steel fabricated mounting of the rack type for power and radio Type 4192 and includes a back-plate 10AR/438.
- (3) *Mounting, Type 7669 (10AJ/237)*. This is an aluminium and steel fabricated rack for mounting either control unit Type 4190 or 4243 and includes back-plate 10AR/441.
- (4) *Mounting, Type 7670 (10AJ/238)*. This is an aluminium and steel fabricated rack for mounting receiver Type R.4187 and includes back-plate 10AR/442.
- (5) *Mounting, Type 7671 (10AJ/239)*. This is an aluminium and steel fabricated rack for mounting transmitter Type T.4188 and includes back-plate 10AR/440.
- (6) *Connector set for test rig installation, Type 7470 (Chap. 1)*.

15. The side members of some of the mounting racks listed above are cut way to give access to components on the unit chassis.

Test rig installation, Type 7471

16. This test rig is additional to the test rig installation, Type 7470 when it is required to test an installation including suppressed aerial equipment. It consists of the following items:—

- (1) *Mounting, Type 7666 (10AJ/234)*. This is an aluminium and steel fabricated rack for

mounting the selector unit, Type 7003, and includes back-plate 10AR/474.

- (2) *Connector set for test rig installation, Type 7471 (Chap. 1)*.

Test rig installation, Type 7472

17. This test rig is additional to the test rig installation Type 7470 when it is required to test an installation including fixed aerial equipment. It consists of the following items:—

- (1) *Mounting, Type 7672 (10AJ/240)*. This is an aluminium and steel fabricated rack for mounting the tuning unit (aerial), Type 7180, and includes back-plate 10AR/444.
- (2) *Connector set for test rig installation, Type 7272 (Chap. 1)*.

Socket, Type 704 (modified)

18. Socket, Type 704 is used in a modified form to facilitate the connection of the 75-ohm terminating unit of the signal generator CT218 to the back-plate associated with the receiver, Type R.4187.

19. The modification is illustrated in fig. 5. Two pieces of 18 S.W.G. copper wire are soldered to the socket, one to the inner connection of the socket and the other to a tag fastened to the screw on the top of the socket.

20. Both wires are then connected to the terminating unit, the centre connection of the socket being made to the 75-ohm terminal and the outer connection of the socket being made to the E terminal of the terminating unit. The two wires should be kept as short as possible when connecting to the terminals on the terminating unit.

Test meter (current), Type 7626

21. The test meter (current), Type 7626 is a portable, single range test meter with a scale range 0–200 microamps. The meter is mounted in a case with leads and accessories as listed below:—

RESTRICTED

TABLE 2
Items for testmeter (current), Type 7626

<i>Ref. No.</i>	<i>Nomenclature</i>	<i>Description</i>	<i>Qty.</i>
5Q/25442	Microammeter M.C.	0-200 microamp., 650 ohms, 3½" dia., flush mounting.	1
10HA/16702	Leads, Type 227 including —	36" long	1
10H/1965	Terminals, Type 16	Spade, hook. O.BA Red	1
10H/1966	Terminals, Type 17	Spade, hook. O.BA Black	1
10H/488	Plugs, Type 1	Telephone jack plug plug 2 pole	1
5E/2968	Cables electric, L.T. unisheath, ground 4	P.V.C. covered 23/·0076	1 ft.
5E/1611	Cables electric, dusheath small 4	2 cores of 23/·0076	9 ft.
5K/1884	Clips connector	Crocodile	2
10H/11290	Plugs, Type 120	2-pole panel mounting. Moulded insulated body. 2-hole fixing "1½ × 1" deep (including contact pins) × ¼" wide. Flange ¼" thick	1
5CY/591	Sockets, Type C, No. 1	2-pole, flat type	1
10H/18797	Sockets, Type 650	2-pole cable mounting ⅝" × ¼" × ⅛" long, whipping post.	1
10H/872	Terminals, Type 1	Non-rotating index bakelite plain black insulated panel mounting. Stem 2BA × ¾" long	2

RESTRICTED

Chapter 1

FAULT LOCATION ON HF RECEIVER, TRANSMITTER AND FIXED AERIAL TUNING UNIT

LIST OF CONTENTS

	Para.		Para.
Control unit Type 4190			
Introduction... ..	1	Mechanical drive unit Type 4212	17
Motor will not operate—tight gearing	3	Spark quench tests	18
Selector motor runs continuously	4	Power and radio unit Type 4192	21
Selector motor will not start	5	Receiver Type R.4187	
Overheating of 12-way potentiometer winding	6	Introduction	24
Adjustment of clicker switch S3J	7	1st and 2nd oscillator	27
Check on freedom of gearing	10	Control circuits, relays and switches	30
Transmitter Type T.4188			
Low output	13	Control unit Type 4189 and junction box Type 4191	33
Over-run of tuning motor	14	Tuning unit (aerial) Type 7180	
No P.A. cathode current	15	Fault location	34
Control circuits	16		

LIST OF TABLES

	Table		Table
Voltage and current readings for transmitter Type T.4188	1	Fault location on power and radio unit Type 4192	4
Fault location on transmitter T.4188	2	Fault location on the receiver	5
Voltage readings for power and radio unit Type 4192 ...	3	Voltage and current readings for receiver Type R.4187	6

CONTROL UNIT TYPE 4190

Introduction

1. Fault location on the control unit Type 4190 is mainly confined to DC point-to-point testing. It should be noted that when the unit is in the "off" condition, several relays are released when compared with the rest condition of STD/BY and thus paths to earth (etc.) are not complete. A "listening rod" applied to relays is a useful check to their operation.

2. The following possible faults are listed under appropriate headings. Care should be taken to limit the servicing to that permitted in "Bay Servicing" (Vol. 4, Part 6).

Motor will not operate—tight gearing

3. This is generally due to the motor worm drive being over-meshed; this may be slackened by using shims (if necessary) in the motor mounting. It may also be due to lack of oil on the bearings, particularly on the potentiometer spindles of the resistor unit Type 4217.

Selector motor runs continuously

4. This may be due to one or more of the following faults:—

- (1) Incorrect adjustment of the clicker switch S3J (the adjustment of this is described in para. 7).
- (2) Faulty switch section S3C or faulty wiring between S3C and its counterpart S1A in the receiver.

Selector motor will not start

5. If the selector motor will not start when the channel selection switch on the remote control unit is changed and the receiver unit has finished selecting, it may be due to one or more of the following faults.—

- (1) Faulty relay RL1.
- (2) Faulty selector motor MG1.
- (3) Fuse 3F2 in power and modulator unit.
- (4) Faulty switch section S3C in control and drive unit.
- (5) Faulty switch section S1A in receiver.
- (6) Open-circuit in wiring between S3C and S1A.
- (7) Loss of 28V supply to relay RL1.

Note . . .

When a fault is peculiar to one channel or one tuning band it can usually be traced from the appropriate circuit.

RESTRICTED

Overheating of 12-way potentiometer winding

6. A permanent earth on the wiper of the potentiometer, i.e. the inner mounting frame will cause the winding to over-heat or burn out.

Adjustment of clicker switch S3J

7. When a wiper on S3A or S3B is in the centre of one of the 12 contacts, there should be 0.062 in. between the "vertical" face of the follower of the spring set and the edge of the notch of the cam into which it has fallen.

8. When the follower is raised to the maximum diameter of the cam, the contacts of the spring set must be separated by 0.030 in. ± 0.007 in.

9. When S9J is properly adjusted and the gearing is running smoothly (*para.* 10) the stopping sequence should operate satisfactorily with:—

- (1) The 19V supply increased to 22V, with the 28V supply normal; and with—
- (2) The 19V supply normal and the 28V supply reduced to 22V. The potentiometer unit must be in position for this test.

Check on freedom of gearing

10. With the potentiometer assembly removed, the application of 6V to the selector motor should turn the gearing freely.

11. With the potentiometer unit in position, the gearing should turn smoothly with 12V on the selector motor.

TRANSMITTER TYPE T.4188

12. The isolation of faults in the RF circuits can best be carried out by the use of the panel-mounted meter 2M1 (for measuring valve currents) and a testmeter Type F for measuring electrode potentials. The readings obtained should conform to within 10 per cent. of those given in Table 1.

Low output

13. Low output, particularly at high frequencies (for example, bad ganging), can be caused by contact wheels or brushes on the tuning coils being on the wrong turn of the coil or off altogether.

Over-run of tuning motor

14. If the tuning motor turns the tuning to one end of the band and continues to operate, thus crashing to the end stop, the cause may be disconnection of the supply to one of the control potentiometers. Check the connections at the back-plates.

No P.A. cathode current

15. When testing the transmitter, check that in the "key up" condition the P.A. cathode current does not fall to zero. Some indication up to 50 mA should be given. If there is no indication of cathode current check R13. If such a fault occurs it may possibly cause flash-over in the modulation transformer.

TABLE I

Voltage and current readings for transmitter Type T.4188

(Conditions: Transmitter tuned on CW, keyed, no drive)

Valve	Electrode	Mark	Volts	Space
V1	Anode	250	—	—
	Screen	250	—	—
	Cathode	4.0	—	—
V2	Anode	320	—	—
	Screen	238	—	—
	Cathode	0.2	—	—
V3	Anodes	630	650	—
	Screens	190	320	—
	Cathodes	30	47	—

Note . . .
Cathode voltages of V3 and V4 are measured at pin 4 of PL5 and screen voltages through hole in valve mountings.

Valve currents are measured on the front panel meter with the transmitter tuned.
 I_1 45 mA; I_2 46 mA; I_c 420 mA

Control circuits

16. The control circuits can be checked as described in Table 2. The tests are made with *only* the LT supplies connected, i.e., 19 volts PL1 pin 7, 28 volts PL1 pin 11, earth PL1 pins 1 and 2 and a wander lead connected to earth (pin 1).

Mechanical drive unit Type 4212

17. The correct operation of the transmitter mechanical drive unit can be checked as follows:—

- (1) Connect a 250-ohm potentiometer between two 5-ohm fixed resistors and connect the complete assembly across pins 12 and 16 of PL1 on the transmitter Type T.4188. Connect the slider of the 250-ohm potentiometer to pin 14 of PL1 thus forming a bridge circuit with RV2 in the mechanical drive unit.
- (2) Ensure that a 28V DC supply is connected to pin 11 of PL1 on the transmitter (and hence to the mechanical drive unit) and then connect a 19V DC supply to pins 12 and 16 with pin 16 to positive.
- (3) With the AUTO/MANUAL switch S3 set to AUTO it should now be possible to operate the mechanical drive unit mechanism by adjustment of the external potentiometer.
- (4) Guard relay RL7. To check the operation of RL7, set the tuning potentiometer to approximately mid-band and connect testmeter Type F across resistor R37 (across pins 1 and 3 of relay RL7). Set S3 to MANUAL and adjust the potentiometer until an indication appears in the testmeter; this should be approximately 5.8 volts, if the reading is not satisfactory, check the guard relay RL7 and the rectifier W1.

RESTRICTED

TABLE 2
Fault location on transmitter T.4188

Circuit	Switch position and external connections	Testmeter	
		Connected between	Indication
Band change	(1) S3 to MANUAL S1 to 2.8-7 Mc/s	Earth and C5	Continuity
		C15	Continuity
Relays: RL1 RL2 RL3	(2) S3 to AUTO and 28V to pin 6 of PL1. Similar results as for (1) should obtain	C24	Continuity
		C29 (in turn)	Continuity
Keying circuits	(1) S2 to I ₁ or I ₂ positions	(1) 1,000 ohms (3W) across testmeter. Testmeter connected between V3, V4 cathode and Earth	(1) Approx. 16 volts
	(2) Earth to keying line (PL1 pin 5)	(2) „	(2) Approx. 23 volts
	(3) Energize Intertune relay RL5 (19V across pins 19 and 10 of PL1)	(3) „	(3) Approx. 16 volts
	(4) Repeat tests (1), (2) and (3)	(4) Anode (top cap) of V2 and PL1 pin 25	(4) (1) More than 10 megohms (2) 69 ohms (3) More than 10 megohms
Interlock	(1) S3 to AUTO or MANUAL	(1) PL1 pins 4 and 8	(1) If supplies have been connected more than 30 seconds (time delay relay RL10 operated) —continuity

Spark quench tests

18. Locate the spark quench rectifiers W4 and W5 connected across the slave relays RL8 and RL9. Make one connection from an oscilloscope to that side of one of the rectifiers connected to the centre stable relay RL6 and make the other connection from the oscilloscope direct to chassis.

19. Engage the tuning motor and adjust the tuning potentiometer until “ticking” commences and a square waveform is observed on the oscilloscope (it is possible to adjust the control in the wrong direction). The oscillogram display should be a square waveform with approximately 20 per cent. overshoot. If the overshoot is large, the rectifier is defective and damage may result to the detector relay.

20. Repeat the test with the oscilloscope connected to the other rectifier.

POWER AND RADIO UNIT TYPE 4192

21. In the audio frequency circuits faults can generally be localized by means of a test meter. Valve voltages are given in Table 3. In general it will be found that these circuits are comparatively free from faults.

22. Reference should be made to Part 1, Chapter 5 for the relay sequences. It should be noted that until relays RL6, RL7 are energized, none of the service relays can be operated.

23. Table 4 shows the indications expected under certain conditions and the circuits proved thereby. The switching circuit in the cathode of the output stage is best proved under operating conditions.

RECEIVER TYPE R.4187**Introduction**

24. Although it is not possible to describe in detail the varied faults which may occur in the receiver, the following information will assist in the diagnosis.

RESTRICTED

TABLE 3
Voltage readings for power and radio unit Type 4192
(Conditions: HT on, CW, MCW, R/T, Keyed)

Note . . . The valves referred to in column 1 are those of amplifying unit Type 4209.

Valve	Electrode	CW		Volts MCW		R/T		Remarks
		Mark	Space	Mark	Space	Mark	Space	
V1	Anode A1	53	—	51	—	—	—	
	Anode A2	53	—	51	—	—	—	
	Cathode C1	11.5	—	11	—	—	—	
	Cathode C2	11.5	—	11.5	—	—	—	
V2	Anode	—	—	—	—	65	—	No input
	Screen	—	—	—	—	40	—	
	Cathode	—	—	—	—	2.5	—	
V3	Anode	—	—	—	—	63	—	
	Screen	—	—	—	—	40	—	
	Cathode	—	—	—	—	2.3	—	
V4	Anode A1	315	335	302	330	302	330	100 per cent. mod.
	Anode A2	315	335	305	327	305	327	
	Cathode C1	10.5	10.5	10.5	10.5	10.5	10.5	
	Cathode C2							
V5 } V6 } V7 } V8 }	Anodes	630	660	59	645	60	645	
	Screens	320	340	305	335	305	335	
	Cathodes	67	54.5	32.5	30	32.5	30	

TABLE 4
Fault location on power and radio unit Type 4192

Conditions supplies, etc.	Testmeter connections		Indication in Test meter	Relay or circuit tested	Remarks			
	Plug or socket No.	Pin No.						
1. No supplies	(a) SK5	1 } 1 }	Short	Back contact of REL2A	Intercom/side tone circuit			
	(b) SK3	3 } 4 }				Short	Back contact of RL9B	Transmitter interlock
	(c) SK1	17 } 15 }						
2. HT fuses F3, F4 removed. 19V and 28V to PL1+19V to SK3 pin 2	SK5	5 }	Short	RL12 energized preparing keying circuit	Power unit starts. In this condition RL8, RL9 energized. Test (1B) above shows open circuit			
	SK1	5 }						
	SK2	5 }						
3. Conditions as in (2), earth applied to SK2 pin 1	—	—	—	RL6 RL7	RL6 energized, operates RL7, heaters switched on			
4. With conditions as in 2 and 3, e.g., power supplies +19V to SK3 pin 2 and earth to SK2 pin 1, proceed as follows:—	(a) Earth to SK2 pin 10	SK2 } SK1 } 25 }	Short	Intertune HT RL1A	Test 1(c) now shows open circuit			
	(b) Earth to SK2 pin 5					Relay RL2 (Key)	Test 1(a) now shows open circuit	
	(c) Earth to SK2 pin 19 or SK1 pin 20	SK1	25 } 22 }	Short	Relay RL11 tune	Increasing to 2,800 ohms when short is removed		
		SK1						

RESTRICTED

TABLE 5
Fault location on the receiver

Set the front panel control TUNE/NORMAL to NORMAL.

Set the controls on the remote control unit as follows:—RF GAIN to maximum; Service switch to R/T.

Symptoms	Adjustment	Expected result	Circuits checked
(1) No low level or background noise, no signal	(a) Service switch to CW1	(a) Click in phones as RL2 on IF amplifier is energized	(a) V7, V8 (Audio) in IF amplifier
	(b) Service switch to CW2	(b) Click in phones as RL1 on IF amplifier is energized; background noise changed in pitch	(b) V2, V5 in IF amplifier
	(c) Set band switches of selected channel to each position in turn	(c) Click in phones and variation in noise level	(c) V4, V5, V6 in RF amplifier
(2) Normal or slightly low level background noise, no signal	Disconnect aerial input by removing co-axial plug from SK5 (Red) on RF unit	Click in phones followed by increase in level of background noise when aerial is connected	V1, V2, V3 in RF amplifier

25. Faults in the signal circuits can generally be localized to a sub-chassis or to two or three stages on that sub-chassis by manipulation of controls when the unit is operating in a bench test rig.

26. Table 5 and para. 27 to 31 show the results expected under different conditions, assuming the HT and LT supplies to be correct.

1st and 2nd oscillator

27. If, after carrying out these tests with satisfactory results, there is still no signal, check, with the aid of the frequency meter set SCR211, that the oscillators are operating.

28. Connect the frequency meter to the second oscillator (2.05 Mc/s) V1 on the IF amplifier unit (a pick-up wire between the valve envelope and the screening can will suffice).

29. Check the 1st oscillator by removing the associated crystal. If the 1st oscillator is operating, there will be a reduction in noise when the crystal is removed.

Control circuits, relays and switches

30. Failures in the control circuits, relays and switches can be traced with a testmeter used in conjunction with LT supplies to carry out a step-by-step check through the circuits.

31. Disconnections on the tuning potentiometers in both the main chassis assembly and the RF amplifier are indicated by false balance conditions appearing as the receiver is tuned.

32. Voltage and current readings for the main

chassis assembly, RF and IF amplifiers are given in Table 6.

CONTROL UNIT TYPE 4189 AND JUNCTION BOX TYPE 4191

33. Fault finding on the remote control unit and the junction box will be mainly confined to continuity testing. The procedure for carrying out tests with the testmeter Type F will be apparent, from the appropriate circuit diagrams. Where necessary switch contacts should be cleaned with gasoline, no-lead (34C/175).

TUNING UNIT (AERIAL) TYPE 7180

Fault location

34. In the RF circuits of this unit, faults are more likely to be mechanical than electrical. Electrical faults will generally cause overheating in the unserviceable component or circuit and can thus easily be identified.

35. The following typical faults cannot be listed under precise headings but will be located in the tuning circuits.

(1) With transmitter tuned, L1 tunes but transmitter will not load. Check aerial, coil L2 and capacitor bank C1 to C6.

(2) Transmitter tunes, but no dip in I_c when the coil L1 is adjusted. A very gradual variation in I_c may be apparent as the coil L1 is moved from end to end or as each series capacitor C1 to C6 is selected. Check L1 and the capacitor bank C1 to C6. Check the RF output line from the transmitter RF output plug 2PL4 to the control and drive unit plug 1PL5, relay contacts 1RL6A and 1PL6 and finally

RESTRICTED

TABLE 6

Voltage and current readings for receiver Type R.4187

Main chassis assembly

Operating voltages

Valve V1 oscillating:—

Anodes 220 volts
 Cathodes C1 21 volts
 Cathode C2 0 volts

HT current measured at F₁ with RF and IF amplifier units disconnected.

V1 not oscillating 12 mA
 V1 oscillating 11 mA

RF and IF amplifier units

Conditions: CW operation, RF gain at maximum, signal in, AGC operating.

Valve	RF amplifier unit Electrode	Volts	Valve	IF amplifier unit Electrode	Volts
V1	Cathode	3.2	V1	Anode	203
				Screen	205
				Cathode	19
V2	Anode	150.0	V2	Anode	87
	Screen	72.0		Screen	55
	Cathode	0.7		Cathode	0.9
V3	Anode	177.0	V3	Anode	67
	Screen	75.0		Screen	53
	Cathode	0.8		Cathode	0.9
V4	Anode	180	V4	Anode	150
	Screen	65		Screen	150
	Cathode	1.2		Cathode	16
V5	Anode	183	V5	Anodes A1	15
	Screen	35		A2	—1.6
	Cathode	0.18		Cathodes C1	24
V6	Anode	170	V6	C2	15
	Screen	55		Anode	150
	Cathode	1.2		Screen	150
			Cathode	1.1	
			V7	Anode	47
				Screen	17
				Cathode pin 4	0.4
			V8	Anode	190
				Screen	192
				*Cathode pin 2	7.6
			V9	*Anode pin 7	0.1
				*Anode pin 2	0.2
				*Cathode pin 1	0.2
				*Cathode pin 5	2.9

*Measured on 10-volt range.

Total HT drain measured at F1 100 mA
 HT drain with RF amplifier unit disconnected 70 mA
 HT drain with IF amplifier unit disconnected 49 mA

RESTRICTED

to the RF input plug 8PL1 on the aerial tuning unit.

- (3) Failure of L1 or L2 may be caused by dirt or grease on the brush, winding or earth contact. Alternatively the brushes may be off the coil or on the wrong turn.

36. In the control and indicator circuits many faults are self-evident, but others require closer inspection. The following faults are given as examples:—

- (1) One of the control motors stops in the wrong position. If the fault is definitely located to this unit, check that the slider on the control potentiometer (RV3, RV4, RV5) is making good contact to the stator. If this proves serviceable, check that the potentiometer has not slipped; it is secured to the drive spindle by two grub screws. (The resistance between wiper and the end of the stator at the ends of the traverse should be $5.5 \text{ ohms} \pm 0.5 \text{ ohms}$.)
- (2) The motor(s) hunts about the tuning point, taking a considerable time (and excessive "ticking") to settle down. Check the associated centre-stable relay (opposition winding) and the series resistors R5, R7 or R9. Check the tuning motors and the associated filters.
- (3) If the motor runs to the end of the traverse and continues to drive against the clutch and end stop, check the supply voltage to the potentiometers. A possible cause of the trouble is in the back-plate contacts.
- (4) The switching circuits can rapidly be proved with the aid of a testmeter.

RESTRICTED

RELAYS (RL)	6A	3A	5A	4	6	5B	6B																																									
CONDENSERS	C1A	C2	C3	C32	C33	C35	2A	1B	C3	2B	1A	C3	C8	C4	C9	C6	7	7A	8	8A	C12	C16	C18	C10	C15	C36	C37	C14	C17	C19	C22	C23	C20	C24	C26	C13	C27	C25	C38	C30	C7	C31	C29					
RESISTORS	R1	R2	RV1	R3	R4	R5	R10	R8	R33	R31	R10A	R15	R16	R17	R18	R19	R20	R21	R18	R22	R24	R26	R23	R25	R27	R28	R29	R30	R31	R32	R33	R34	R35	R36	R37	R38	R39	R40	R41	R42	R43	R44	R45	R46	R47	R48	R49	R50

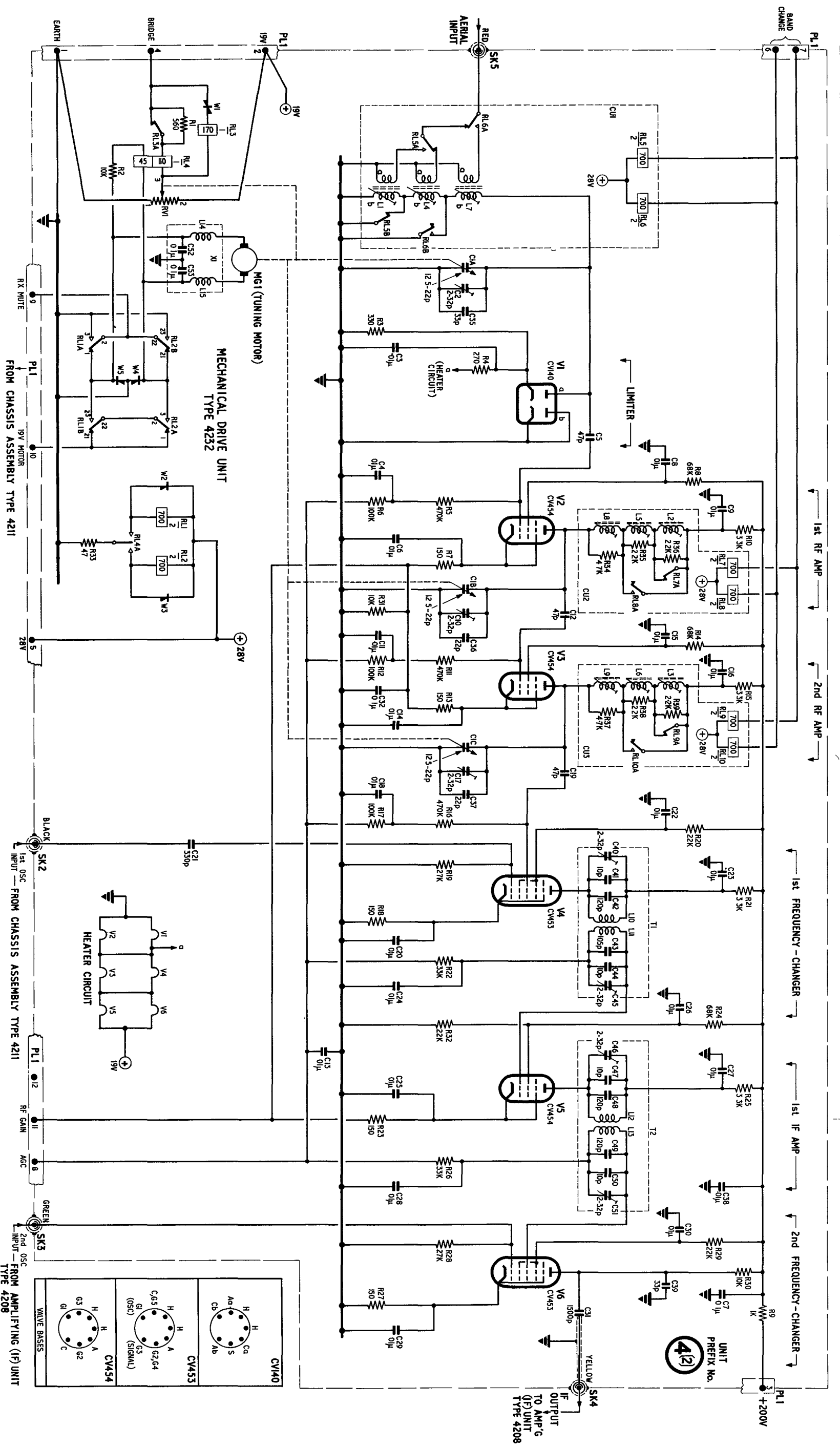

AIR DIAGRAM
6103E/MIN.
PREPARED BY MINISTRY OF SUPPLY
IN CO-OPERATION WITH
AIR MINISTRY

A.R.I.5874 - Amplifying unit (RF) Type 4207 - circuit (Receiver R4187)
RESTRICTED

462723 / 7318 625 11/54 88Ld Gp 979

Fig. 13

(A.L.9 Oct 54)

CONDENSERS		C1	C2	C3	C4	C5	C6	C7	C8	C9	C10	C11	C12	C13	C14	C15	C16	C17	C18	C19	C20	C21	C22	C23	C24	C25	C26	C27	C28	C29	C30	C31	C32	C33	C34	C35
RESISTORS		R1	R2	R3	R4	R5	R6	R7	R8	R9	R10	R11	R12	R13	R14	R15	R16	R17	R18	R19	R20	R21	R22	R23	R24	R25	R26	R27	R28	R29	R30	R31	R32	R33	R34	R35

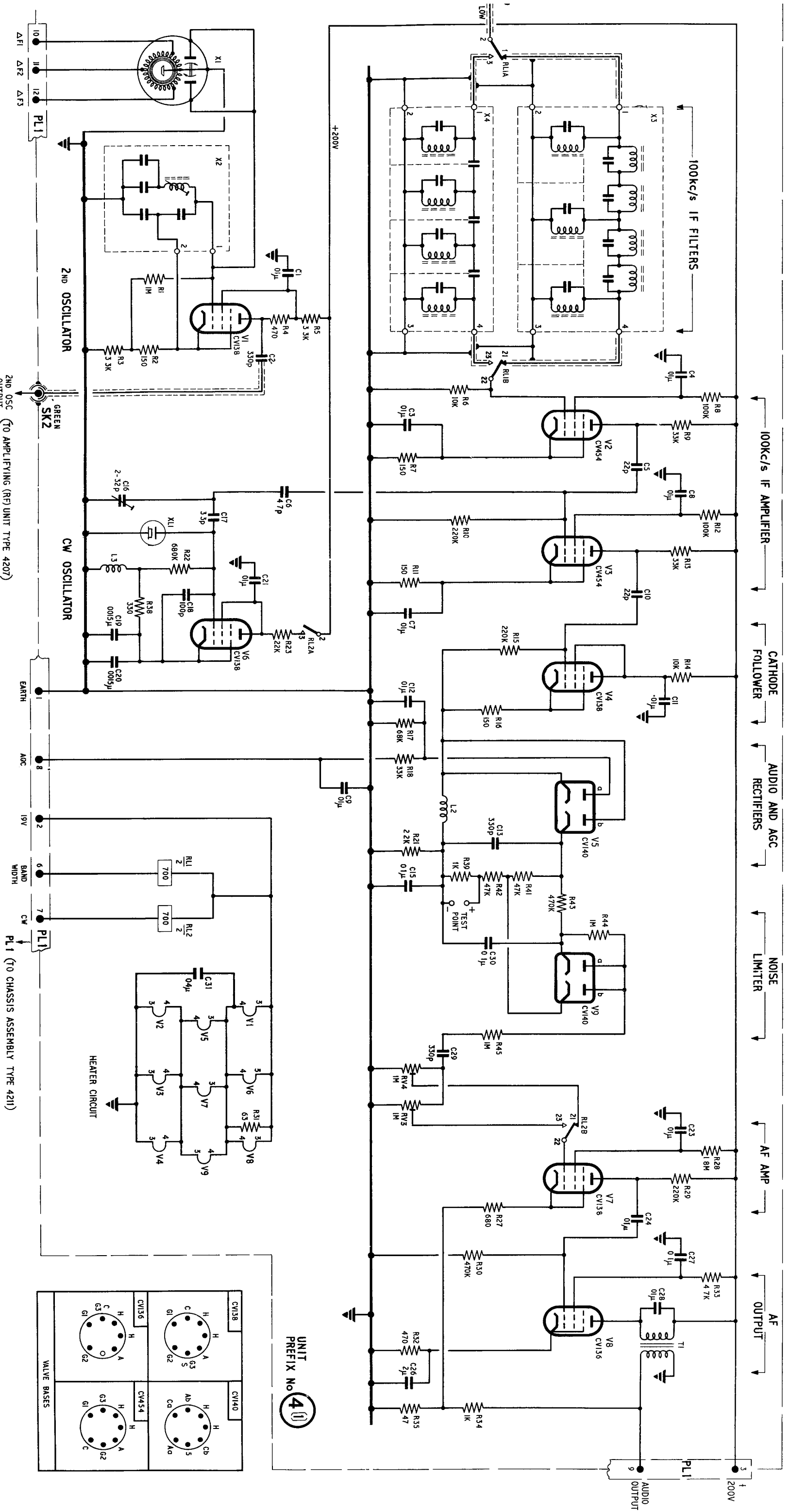

ARI.5874 - Amplifying unit (I.F.) Type 4208 - circuit (Receiver R4187)

RESTRICTED

Fig 14

462723 / 7318 625 11/54 BRUD Gp 979

(A.L.9 Oct 54

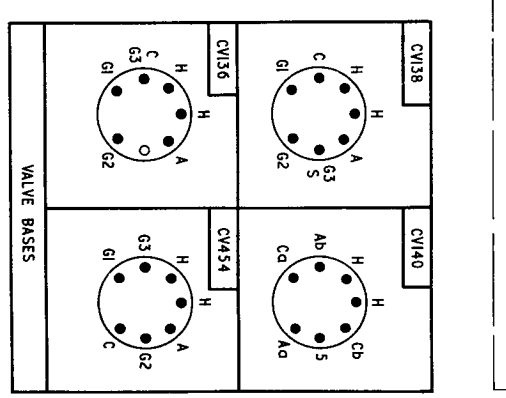

UNIT PREFIX NO (41)

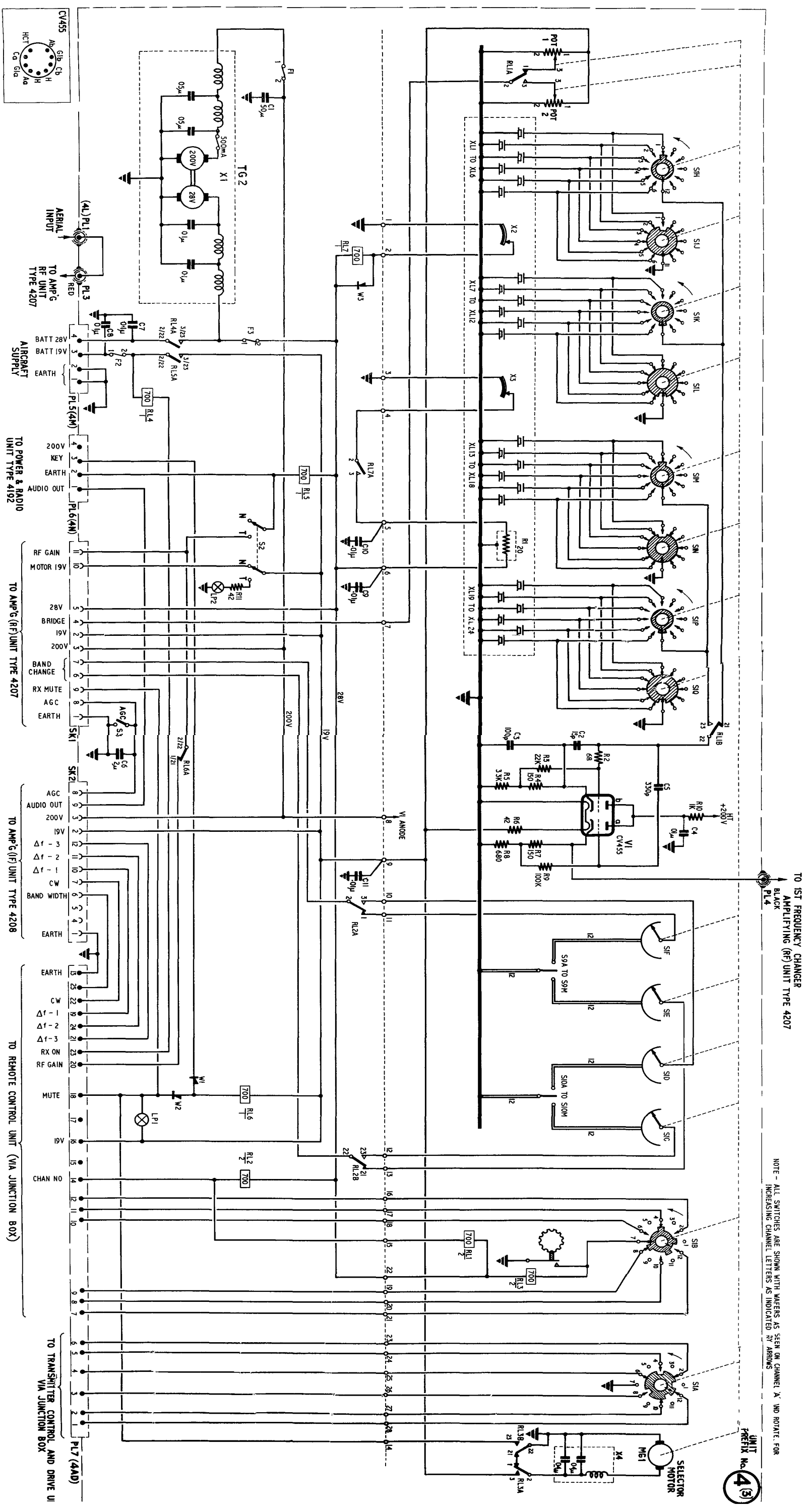

AIR DIAGRAM
6/03G/MIN
PREPARED BY T. S. STAY OF TUMV
FOR REVISION ON 31
AIR NUMBER
ISSUE 1

AR15874 - Chassis assembly Type 4211 - circuit (Receiver R4187)
RESTRICTED

462723 / 7318 625 11754 88UD Gp 979

Fig. AL 9. Oct

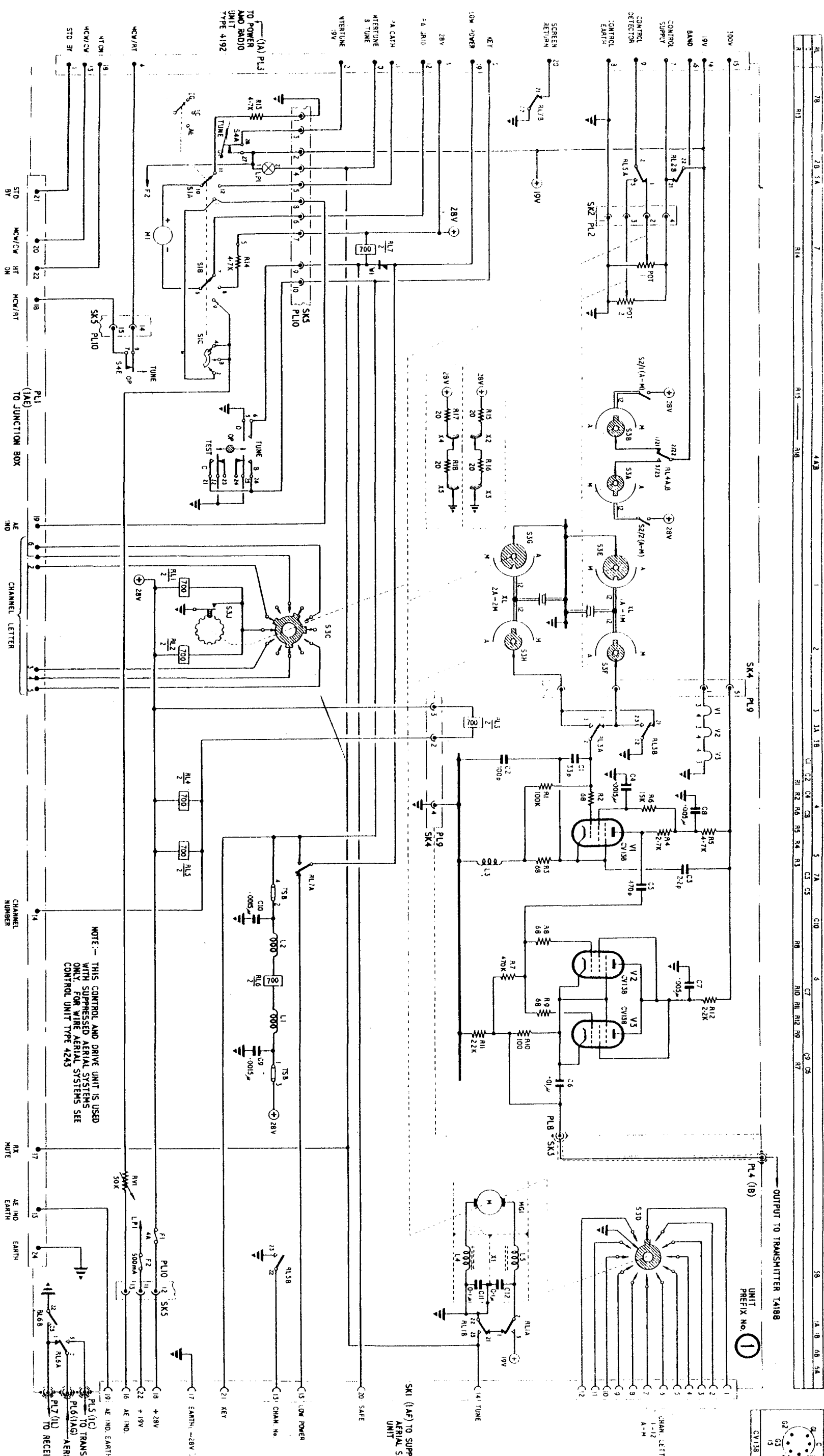

AIR DIAGRAM
61030/MIN.

C.2006 470927 S.W. 3165

ARI. 5874 - Control unit Type 4190-circuit

RESTRICTED

Fig. 5
(A.L. 7 Sep '54)

RL	3	2	10	38	3A	4A	5A	28	2A	4	58	4B	1A	10A	C25	1B	9A	9B	7A	6	8A	8B	7	6A	8	9	5
C	C36	C37	C1	C3	C2	C6	C8	C5	C4	C34	C11	R15	R16	R17	R14	R22	R18	R24	R27	C20	C7	C18	C21	C24	C29	C38	C39
R	R1	R2	R3	R4	R11	R20	R3	R6	R19	R13A	R13B	R13C	R13D	R13E	R13F	R13G	R13H	R13I	R13J	R13K	R13L	R13M	R13N	R13O	R13P	R13Q	R13R

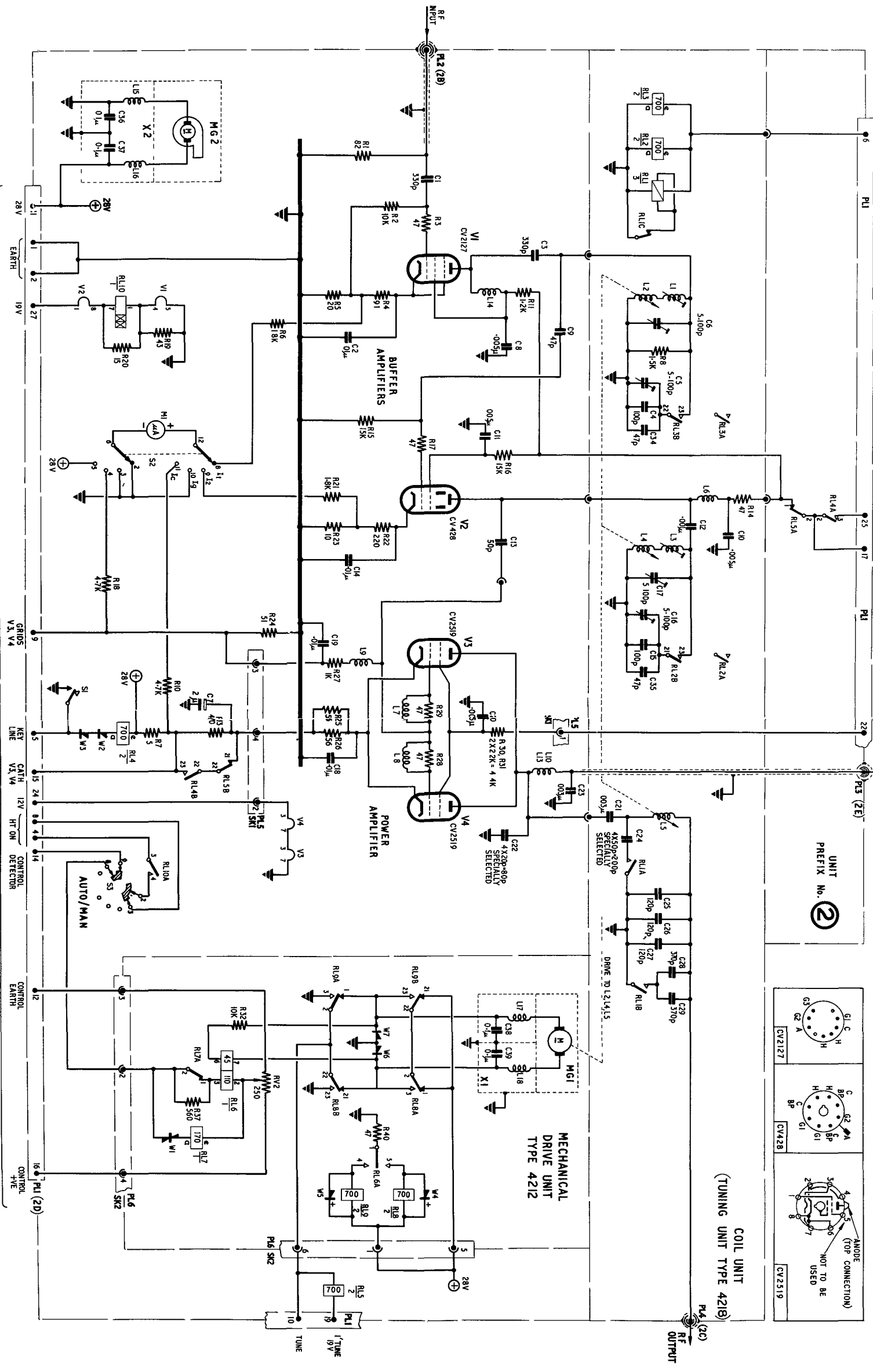

AIR DIAGRAM
6103C/MIN.
ISSUE 1

ARI 5874 — Transmitter Type T 4188-circuit
RESTRICTED

451288/6303 625 9/54 B81LD GP 979
A.L.6, Aug.

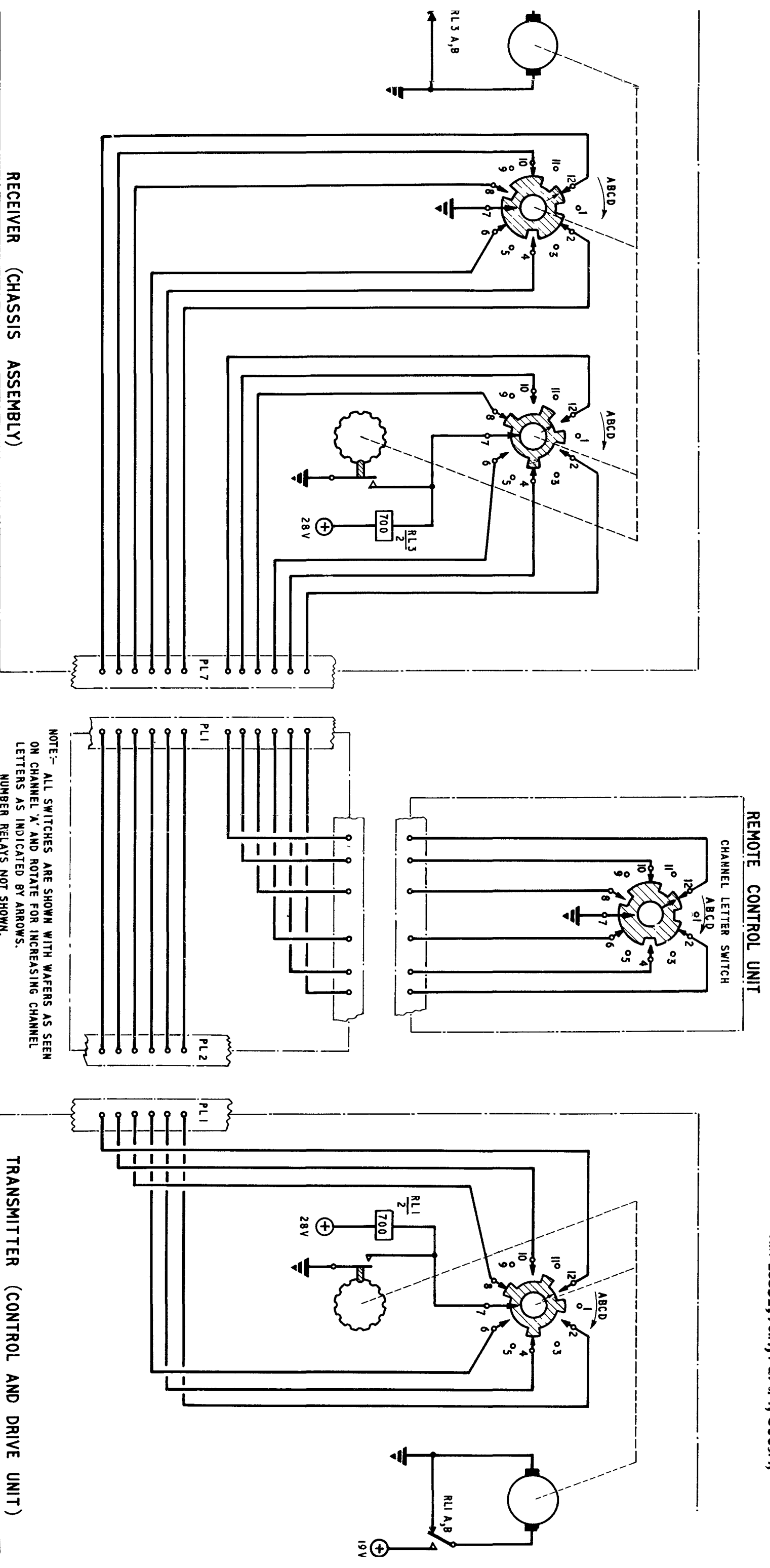

ARI. 5874 - Channel selection circuits - simplified

RESTRICTED

Fig. 3

RL	2A	12A	4A	4B	5A	1A	4	5	11	58	28	18	3A	11B	7	3	2	6A	7A	11A	6	9A	10A	10	9	12	8A	8	9B							
C	C1	C2	C3	C4	RV1	R4	R13	C6	C7	R14	R16	R17	R22	R23	R24	R30	R40	R49	R25	R26	R42	R43	R41	R27	R29	R45	R51	C22	C24	C25	C31	C34	C35	R44	R45	R30
R	SK4	SKA	SKB	SKC	SKD	SK5	SK6	SK7	SK8	SK9	SK10	SK11	SK12	SK13	SK14	SK15	SK16	SK17	SK18	SK19	SK20	SK21	SK22	SK23	SK24	SK25	SK26	SK27	SK28	SK29	SK30	SK31	SK32	SK33	SK34	SK35

A.P.2535E, Vol. 1, Part 1, Sect 1, Chap 5 (A.L.5)

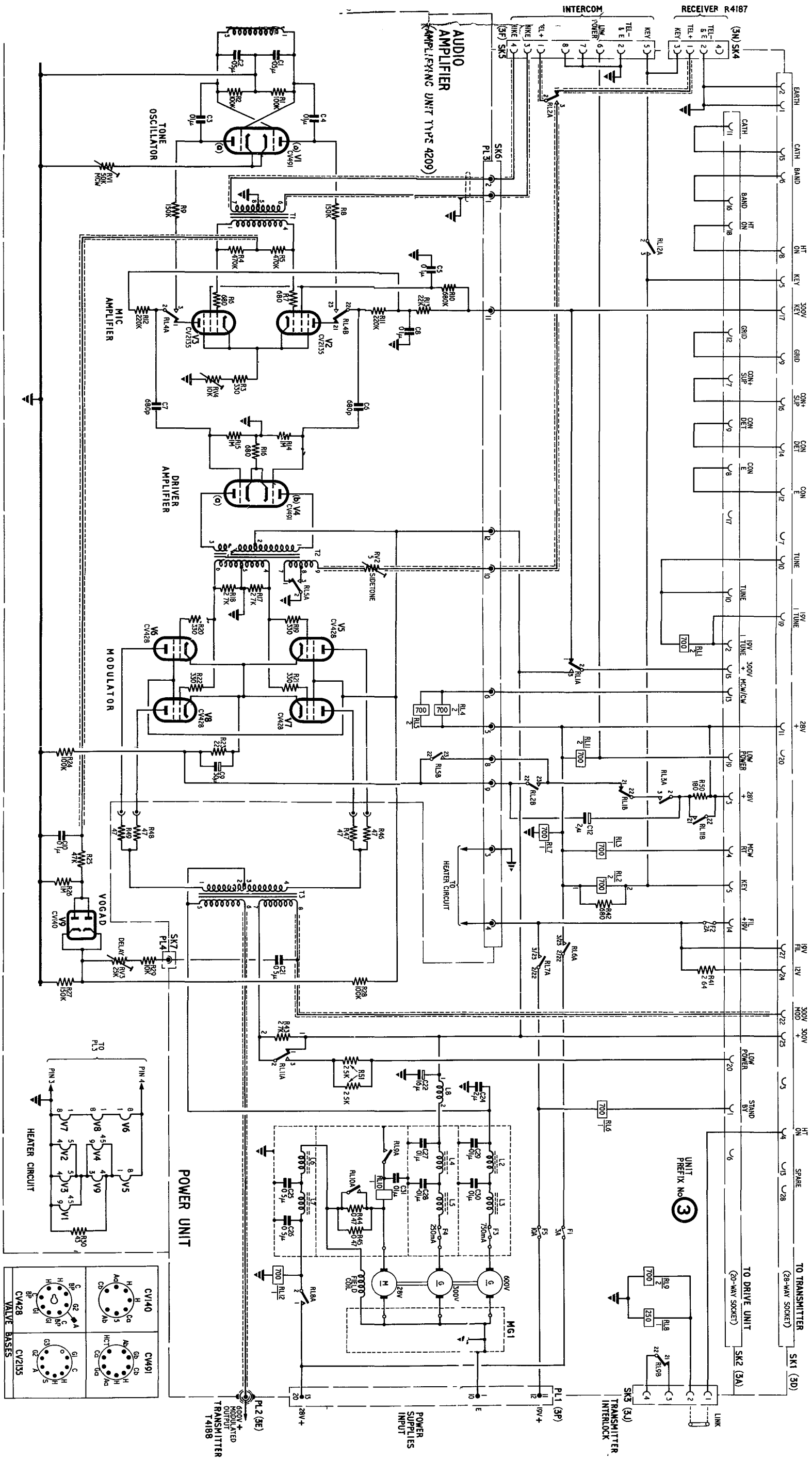

AIR DIAGRAM
6103B/MIN
PREPARED BY HUNTER OF SUPPLY
FOR INFORMATION BY A.F. 2535E

ARL 5874 — Power and Radio unit Type 4192 - circuit
RESTRICTED

451285/6305 625 9/54 B8LId Gp 979

Fig. 7
A.L.5, Aug 54

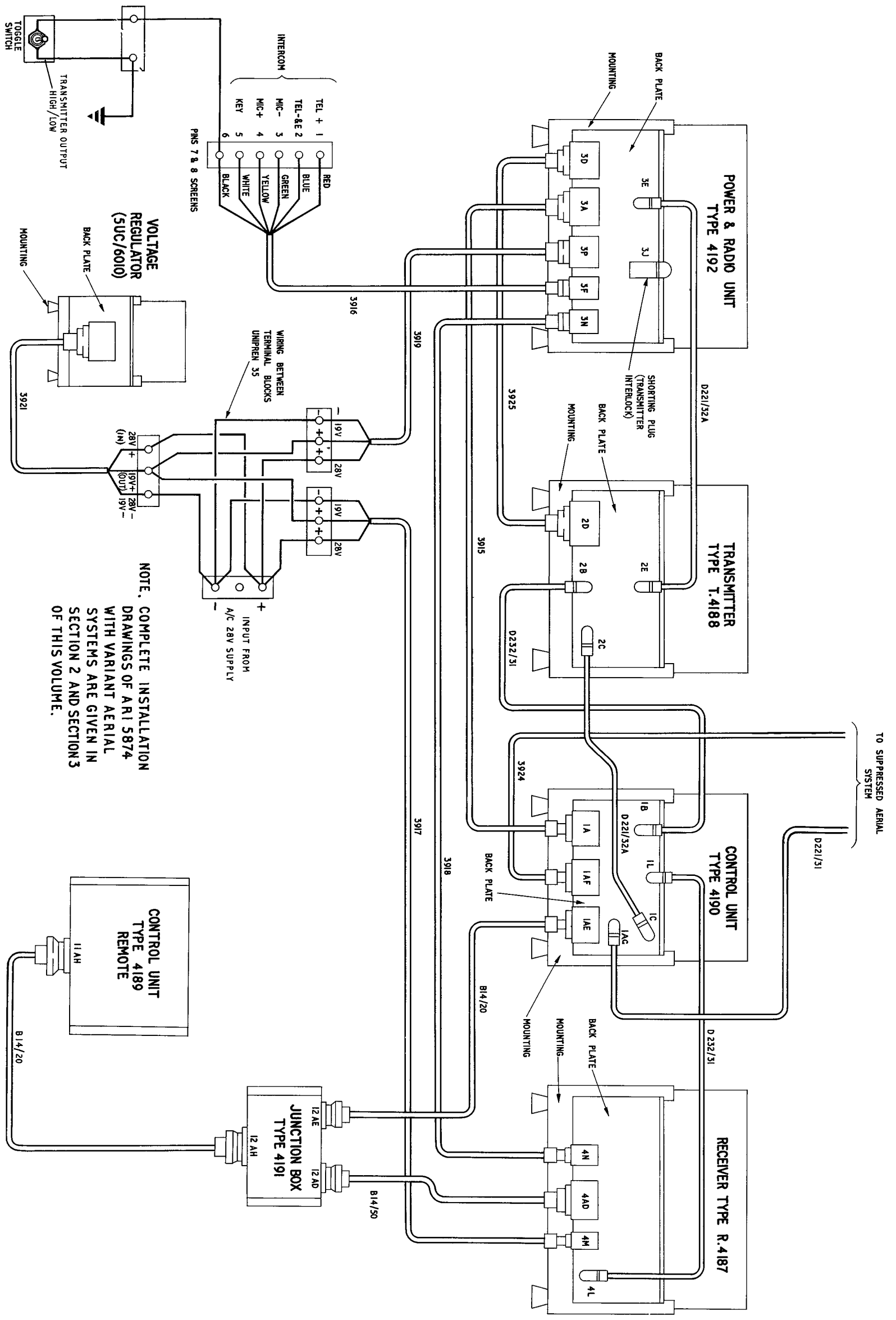

Fig. 8

ARI. 5874 arranged for suppressed aerial system

RESTRICTED

469485 / 8136 625 7/55 B1Ld Gp 979

Fig. 8

(A.L. 10, Nov. 54)

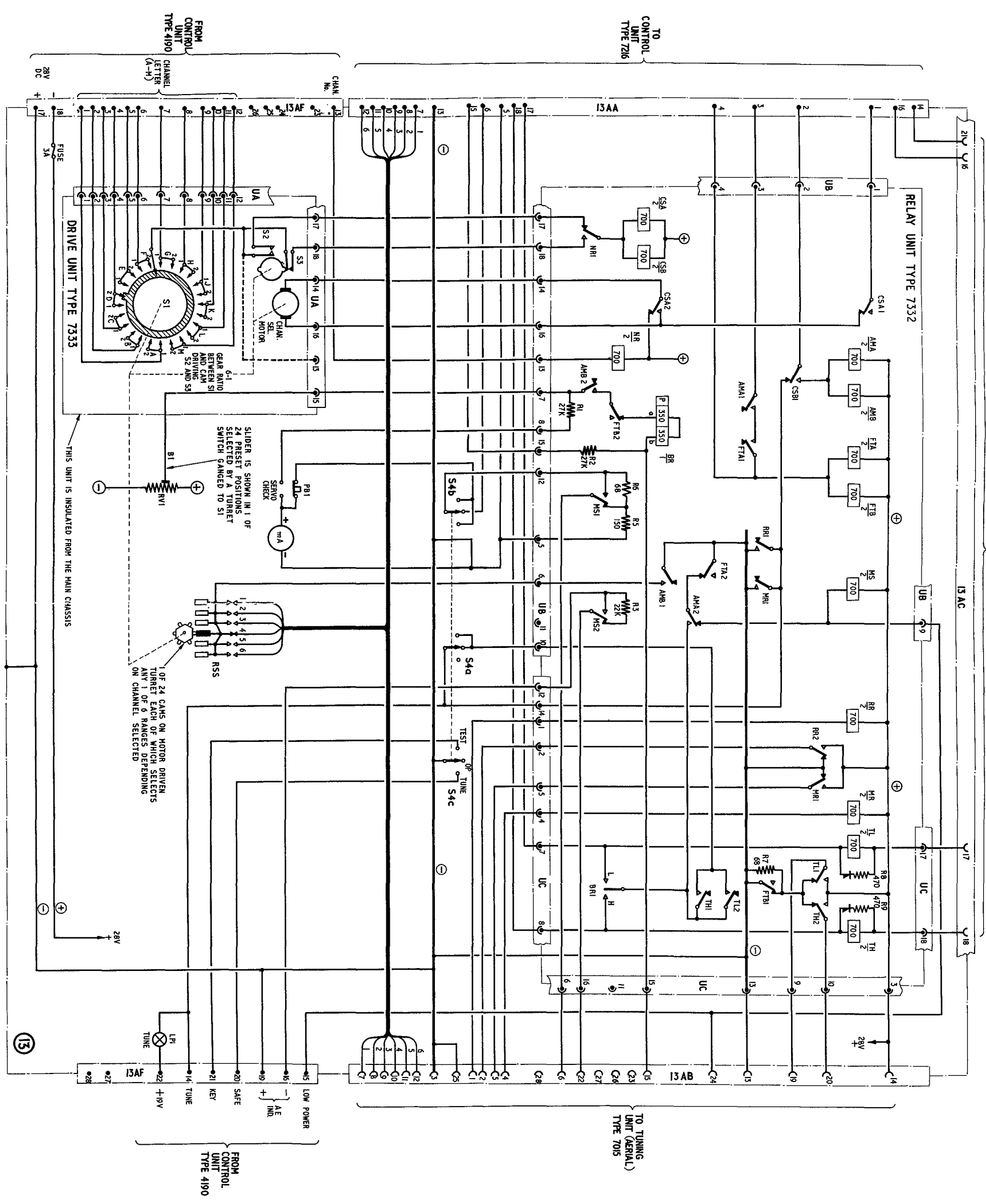

Fig. 4

Selector unit Type 7003 - circuit

RESTRICTED

Fig. 4

(A.L. 25 Aug. 55)

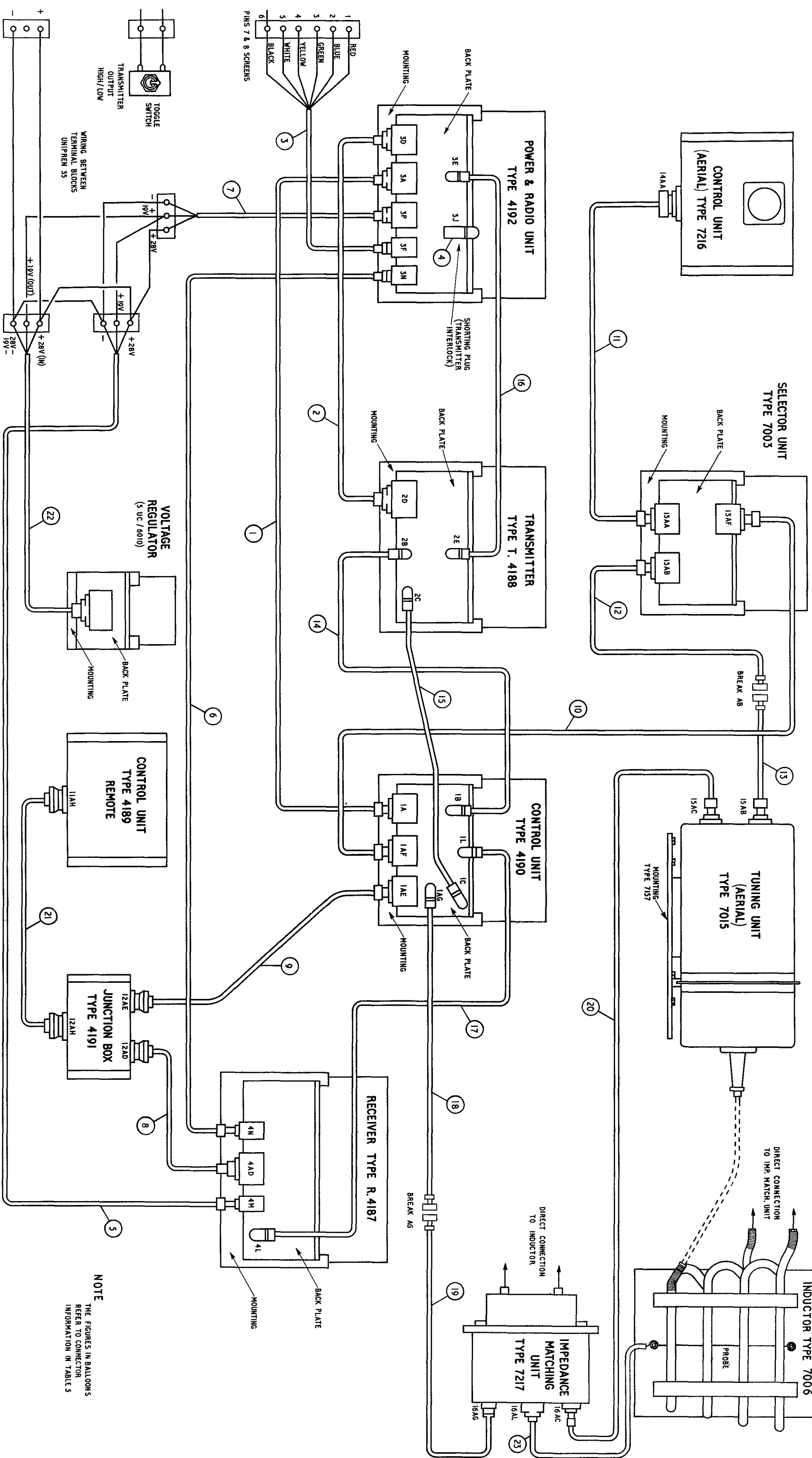

AR1. 5874 with suppressed aerial system Type 7215

RESTRICTED

Fig. 3

(AL/18, May 55)

537644 / 2484 625 655 881d Gp. 979

**14 CONTROL UNIT
TYPE 7216**

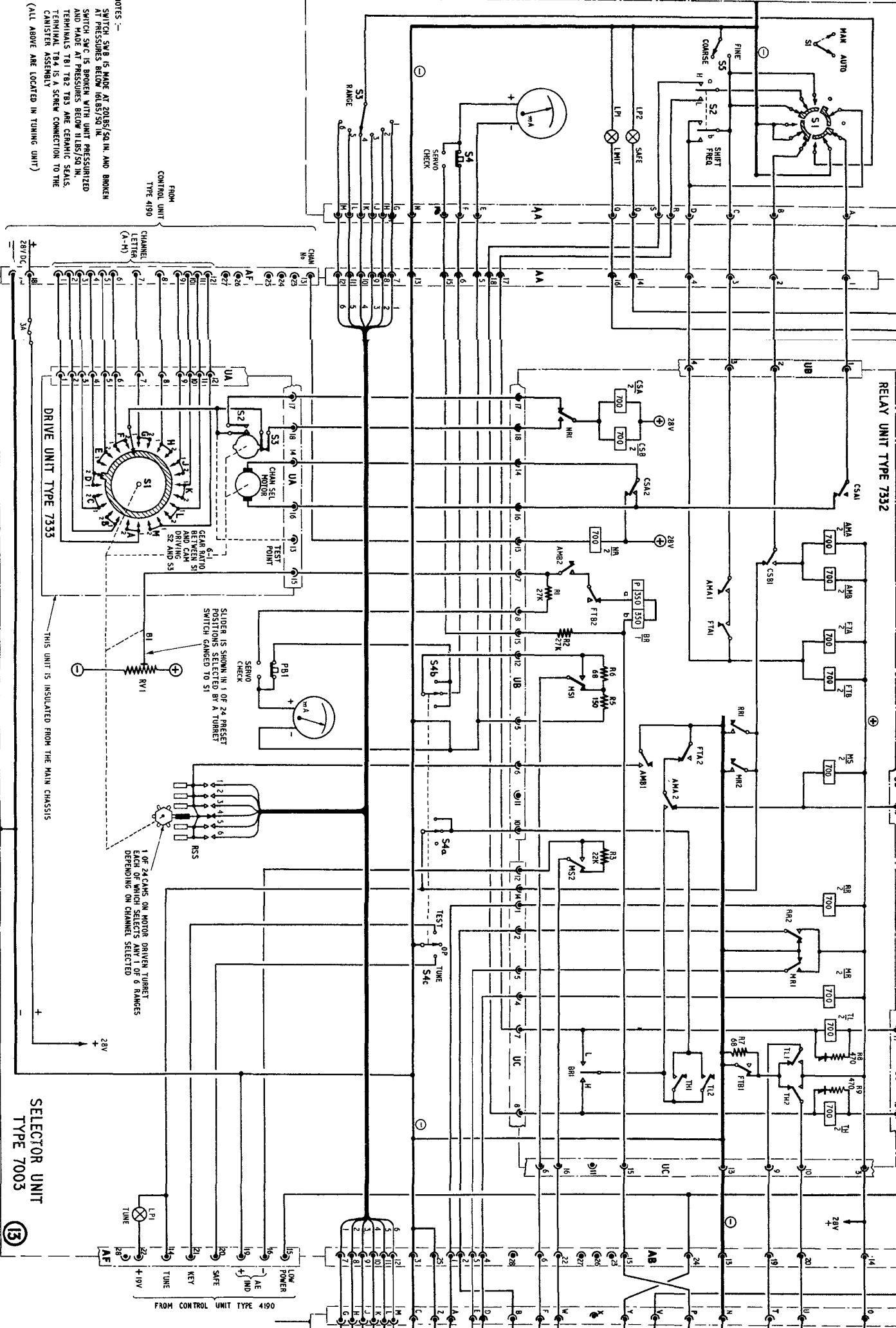

- NOTES -
- 1 SWITCH SW B IS MADE AT 20186/50 IN. AND BROKEN AT PRESSURES BELOW 14.85/50 IN.
 - 2 SWITCH SW C IS BROKEN WITH UNIT PRESSURIZED AND MADE AT PRESSURES BELOW 11.85/50 IN.
 - 3 TERMINALS T81 T82 T83 ARE CERAMIC SEALS.
 - 4 TERMINAL T84 IS A SCREW CONNECTION TO THE CANISTER ASSEMBLY.
- (ALL ABOVE ARE LOCATED IN TUNING UNIT)

**AIR DIAGRAM
61035 /MIN.**

ISSUE 1
REPLACES AIR DIAGRAM 61035 /MIN.
FOR INFORMATION BY AIR INVENTOR

**ARI 5874 - Aerial system Type 9502 - circuit for Vulcan
RESTRICTED**

**TUNING UNIT
TYPE 7016**

OPERATION OF SWITCH SWF

SWF	1	2	3	4	5	6
SWF A	0	0	0	0	0	0
SWF B	0	0	0	0	0	0
SWF C	0	0	0	0	0	0
SWF D	0	0	0	0	0	0
SWF E	0	0	0	0	0	0
SWF F	0	0	0	0	0	0

0 SIGNIFIES OPEN
H SIGNIFIES MADE

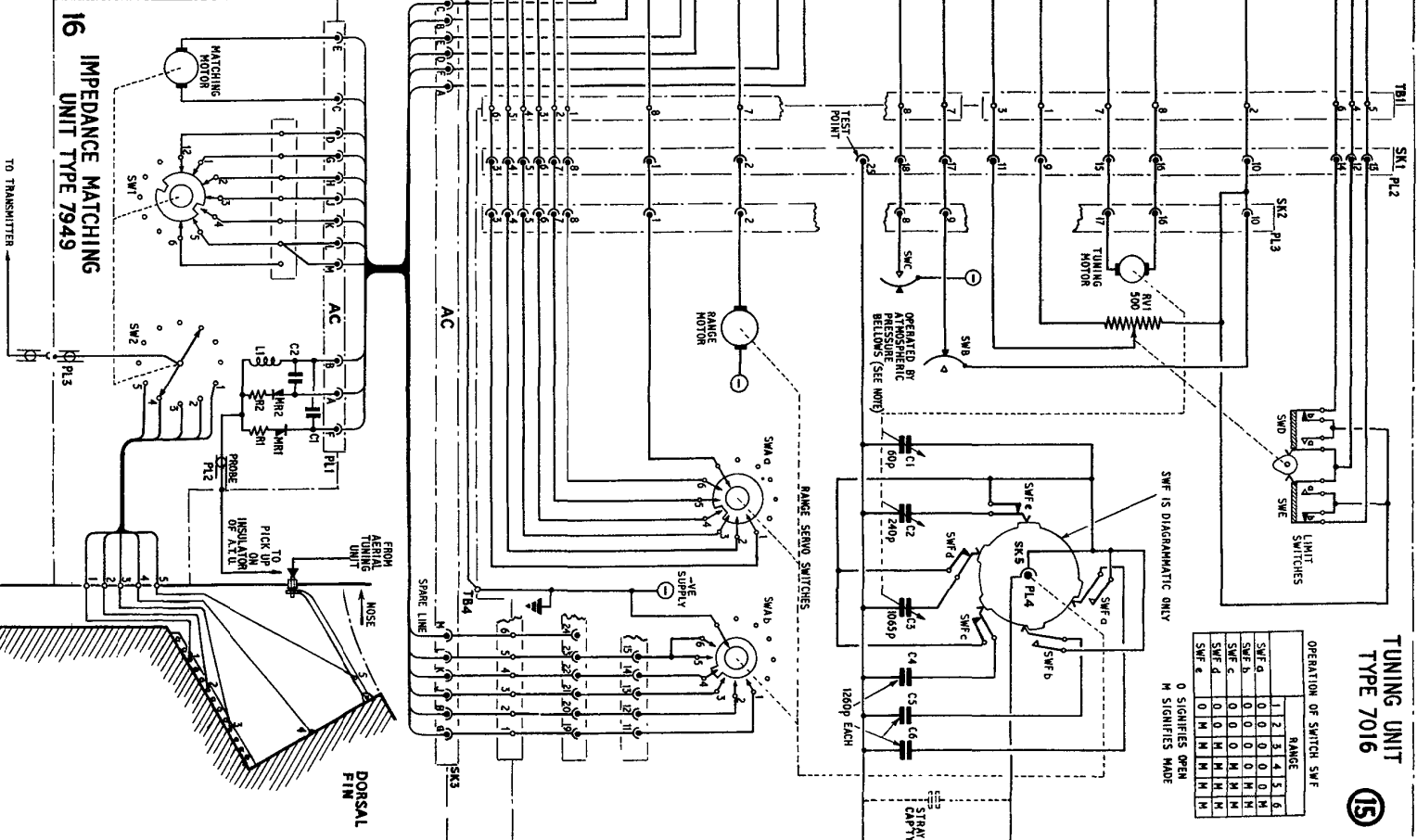

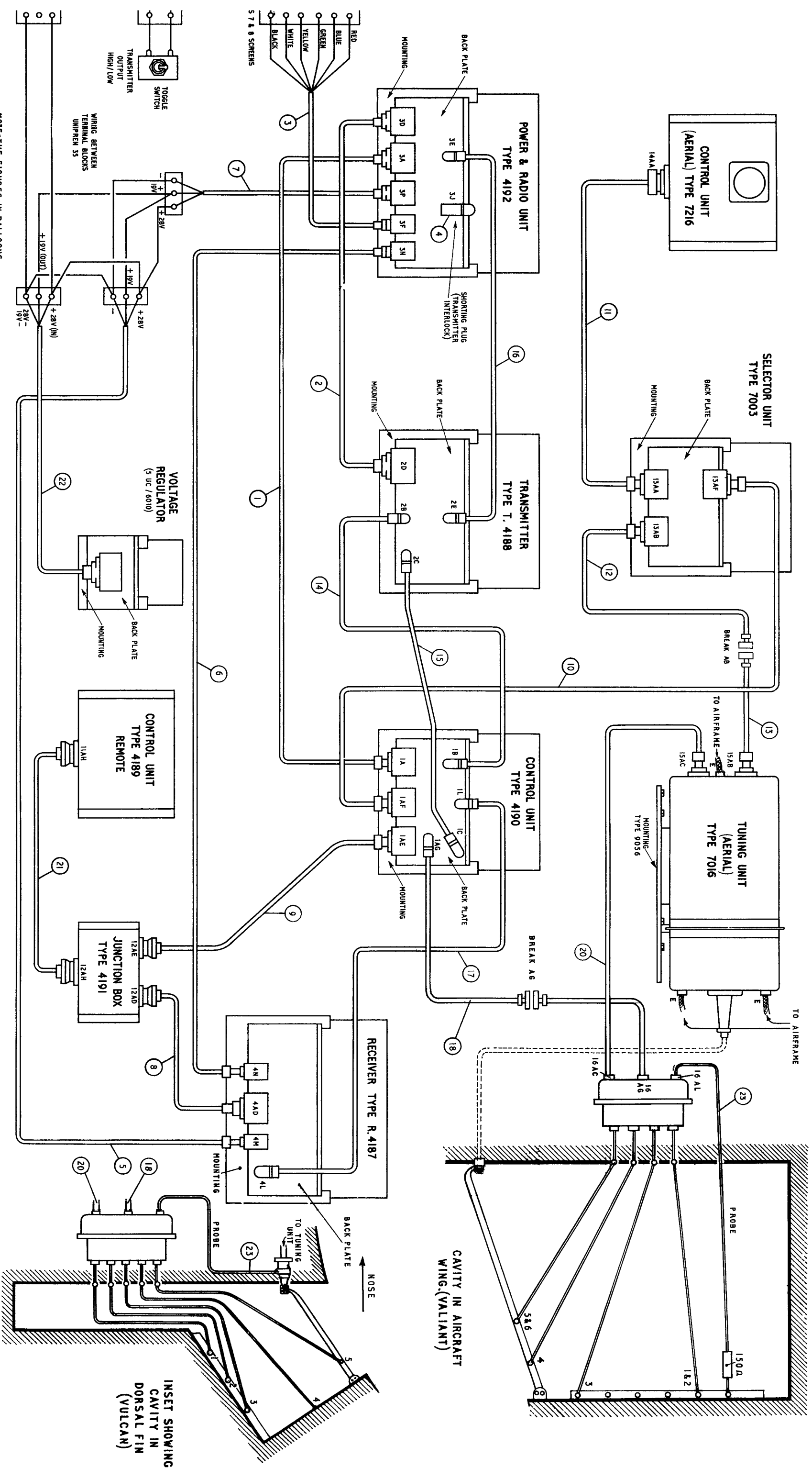
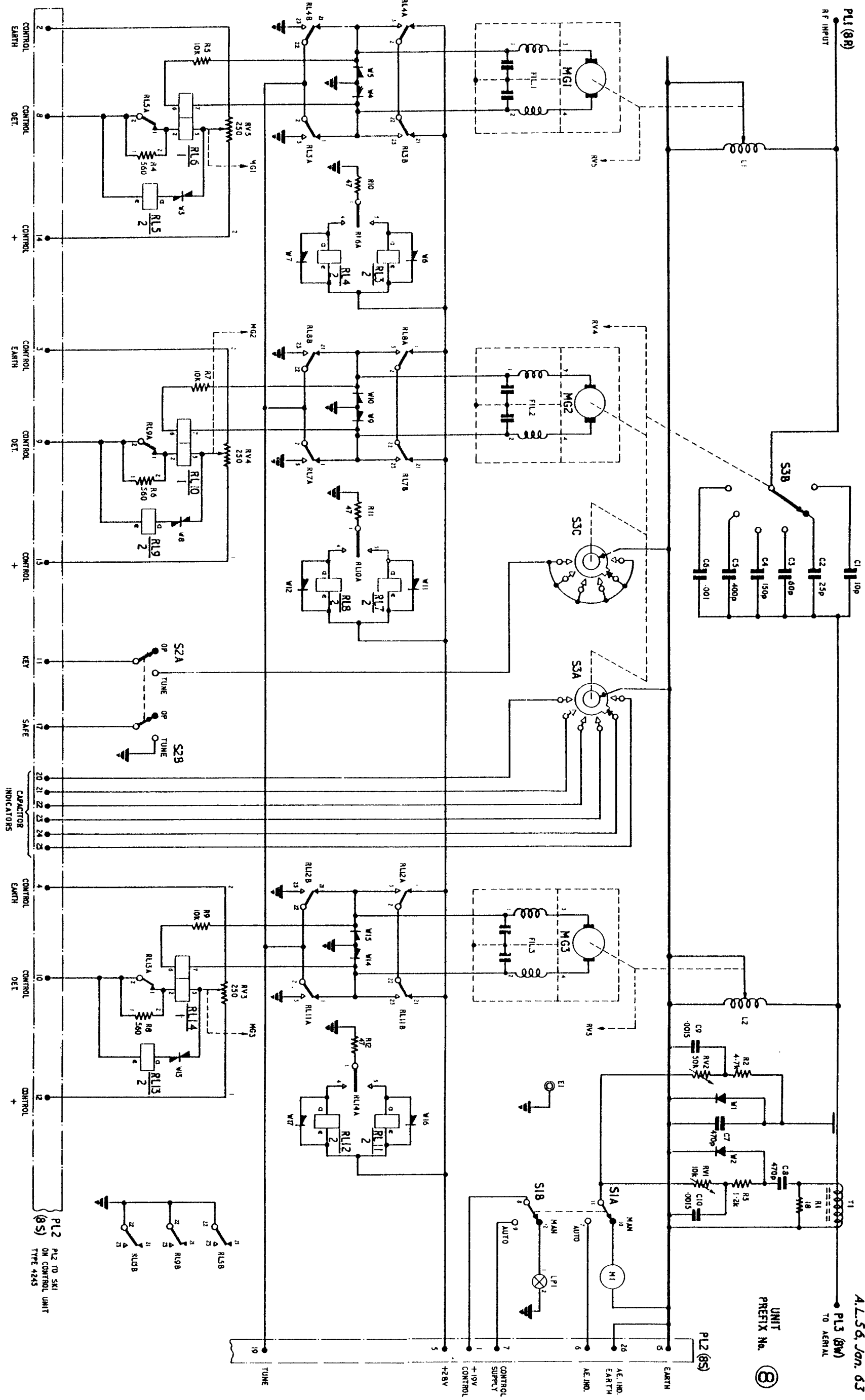

Fig 4

ARI. 5874 with suppressed aerial system Type 9502-Valiant & Vulcan
RESTRICTED

(AL42 April 57)

UNIT PREFIX No. (8)



AIR DIAGRAM
6103K/MIN.
PREPARED BY INSTITUTE OF AVIATION
FOR REPLICATION BY
THE SERVICES

PP9319 2006/470926 2.65 C. & P

ARI.5874 - Tuning unit (serial) Type 7180 - circuit

RESTRICTED

Fig 6

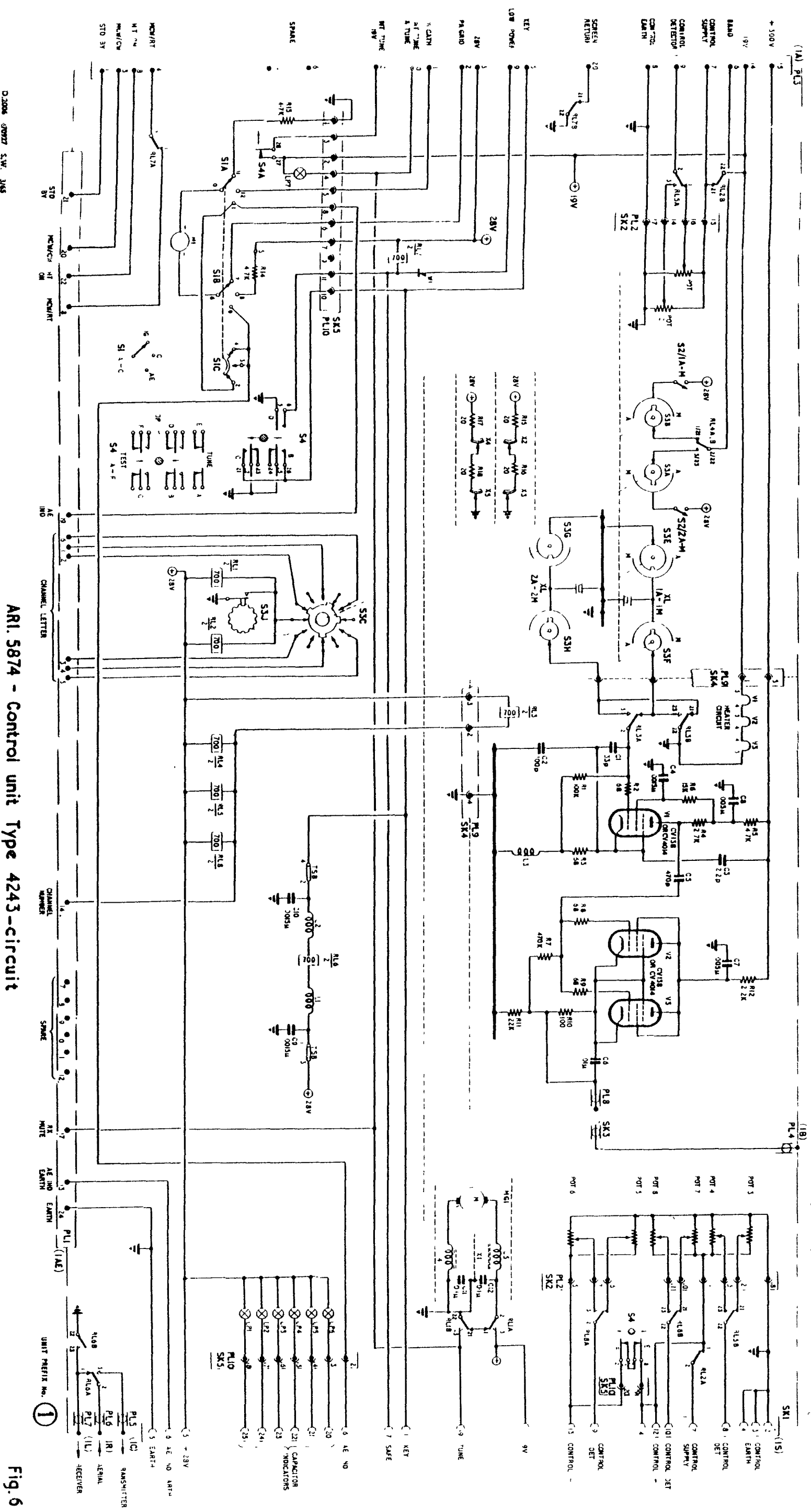

RESTRICTED

ARI. 5874 - Control unit Type 4243-circuit

ALL 22 Jun