

TF 1245

**CIRCUIT
MAGNIFICATION
METER**

Operating and Maintenance Handbook

MARCONI INSTRUMENTS LIMITED
ST. ALBANS HERTFORDSHIRE ENGLAND

Alternative Colour Coding
for Mains Leads
(Red - Black - Green series)

WARNING

The colour coding on mains leads is being changed to conform with international recommendations. During the change-over period, the instrument with which this manual is issued may be wired in either the old or new colours as follows:

	Old colour code	New colour code	Sleeve symbol
LINE (PHASE)	Red	Brown	
NEUTRAL	Black	Blue	N
EARTH (GROUND)	Green	Green/Yellow	

ERA - 3
1 - 5/69

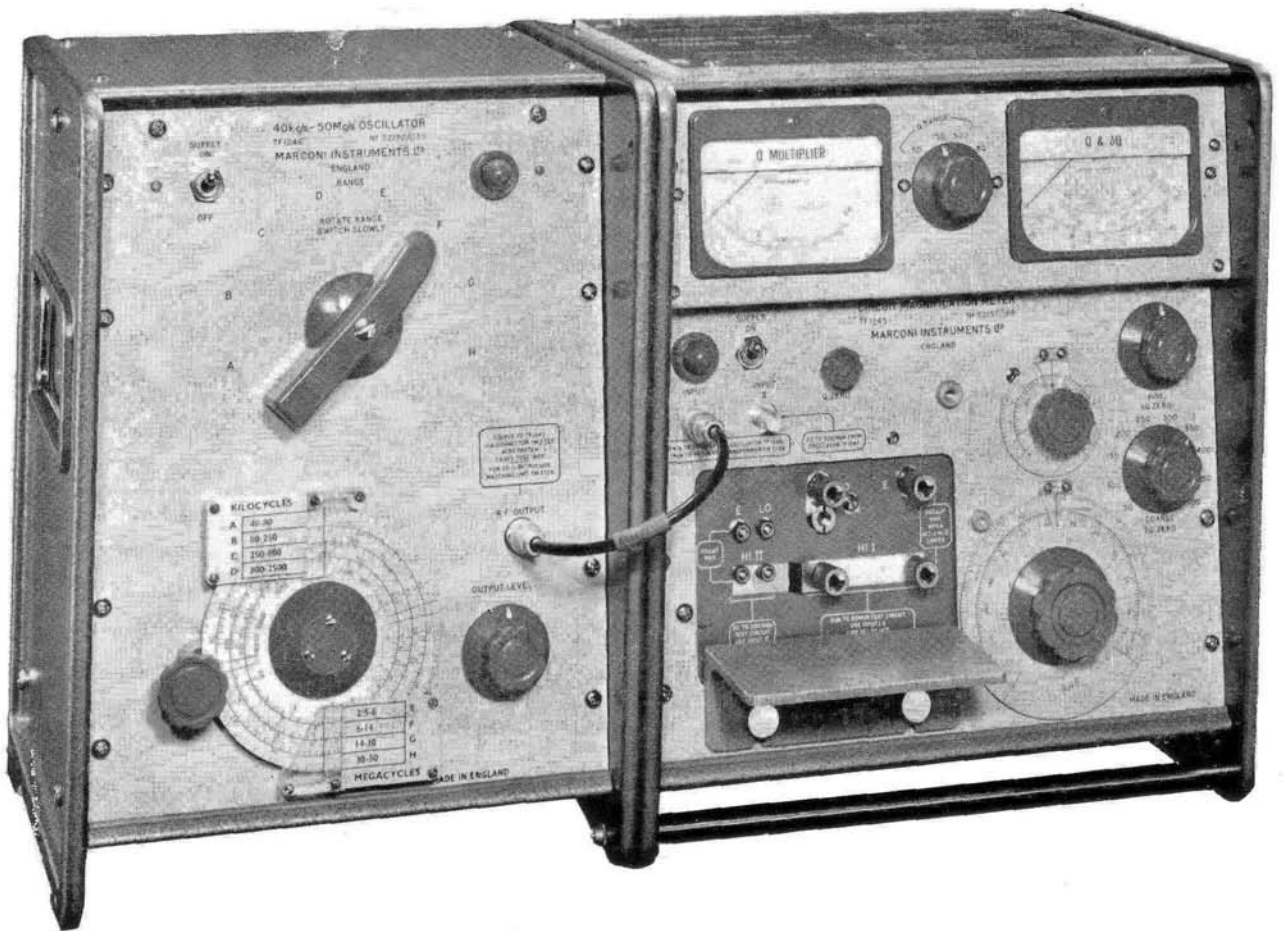

OPERATING AND MAINTENANCE HANDBOOK

No. OM 1245

Circuit Magnification Meter

TF 1245

MARCONI INSTRUMENTS LTD. ST. ALBANS HERTFORDSHIRE ENGLAND

CONTENTS

<i>Section</i>		<i>Page</i>
	SCHEDULE OF PARTS SUPPLIED	5
	DATA SUMMARY	6
1	INTRODUCTION	8
1.1	GENERAL	8
1.2	OPTIONAL ACCESSORIES	8
1.2.1	1- to 40-kc/s Matching Transformer	8
1.2.2	Inductors, Types TM 1438 (Series) and TM 4947 (Series)	9
1.2.3	Dielectric Loss Test Jigs, Types TJ 155B/1 and TJ 155C/1	9
1.2.4	Series Loss Test Jig, Type TJ 230	9
2	OPERATION	11
2.1	INSTALLATION	11
2.2	SETTING UP	11
2.2.1	Oscillator Selection	11
2.2.2	Bonding the Oscillators	12
2.2.3	Initial Measurements	12
2.3	BASIC Q-MEASUREMENT PROCEDURE	12
2.3.1	Setting Zero	12
2.3.2	Making a Measurement	12
2.3.3	Use of the Q-MULTIPLIER Meter	13
2.3.4	Use of the δQ Facility	13
2.3.5	Use of the δC Facility	14
2.4	CONNECTION OF TEST COMPONENTS	14
2.4.1	General	14
2.4.2	L.F. Test Circuit	14
2.4.3	H.F. Test Circuit	14
2.4.4	Cross-Connection between Circuits	15
2.4.5	Connection for Series Measurements	15
3	OPERATIONAL SUMMARY	16
4	Q-METER THEORY	17
4.1	DEFINITION OF Q AND TAN δ	17
4.2	BASIC CIRCUIT ARRANGEMENTS	17
4.3	CORRECTIONS	18
4.3.1	Self-Capacitance of Circuit Inductor	18
4.3.2	Circuit Capacitor Losses	18
4.3.3	Residual Inductance	19
4.3.4	Injection Impedance	20
4.3.5	Voltmeter Resonance and Transit Time	21
4.3.6	Connecting Lead Inductance	21
4.3.7	Summary	22
4.4	DISTRIBUTION OF RESIDUAL COMPONENTS	23

<i>Section</i>		<i>Page</i>
5	MEASUREMENTS WITH CORRECTIONS	24
5.1	MEASUREMENTS ON INDUCTORS	24
5.1.1	Q—Direct Method	24
5.1.2	Q—Incremental-Capacitance Method	24
5.1.3	Additional Corrections for Q Measurement	25
5.1.4	L, C ₀ and R—Natural Frequency Method	25
5.1.5	C ₀ —Frequency Doubling Method	26
5.1.6	L—Direct Method	26
5.1.7	L and R—Series Method	27
5.1.8	R—General Method	28
5.2	MEASUREMENTS ON CAPACITORS	28
5.2.1	C, Tan δ and R—Small-Value Capacitors	28
5.2.2	C, Tan δ and R—Large-Value Capacitors	28
5.2.3	Absolute Capacitance and Self Inductance—General	29
5.2.4	Absolute Capacitance and Self Inductance—Natural Frequency Method	29
5.2.5	Self Inductance—Direct-Frequency Method	30
5.3	MEASUREMENTS ON RESISTORS	31
5.3.1	Introduction	31
5.3.2	R and C—Large-Value Resistors	31
5.3.3	R and C—Small-Value Resistors	31
5.4	MEASUREMENTS ON TRANSMISSION LINES	32
5.4.1	Introduction	32
5.4.2	Effective Shunt Capacitance and Conductance	33
5.4.3	Effective Series Inductance and Resistance	33
5.4.4	Calculation of Transmission Line Constants	33
5.5	MEASUREMENTS ON INSULATING MATERIALS	35
5.5.1	Preparing the Specimen	35
5.5.2	Making a Measurement	36
5.5.3	Calculating the Result	36
6	TECHNICAL DESCRIPTION	37
6.1	GENERAL	37
6.2	MECHANICAL LAYOUT	37
6.3	VOLTAGE INJECTION SYSTEMS	38
6.4	VALVE VOLTMETER	38
6.5	POWER SUPPLY... ..	39
7	MAINTENANCE	40
7.1	GENERAL	40
7.2	MAINS TRANSFORMER ADJUSTMENT	40
7.3	FUSES	41
7.4	ACCESS TO COMPONENTS	41
7.5	WORKING VOLTAGES	41
7.6	REPLACEMENT OF VALVES	41
7.6.1	Removal of Q and δ Q Meter Input Diode, V4	41
7.7	PRESET COMPONENTS	43
7.7.1	Injection Potentiometers	43
7.7.2	Adjustment of Presets	43

<i>Section</i>		<i>Page</i>
7.8	SCHEDULE OF TESTS	43
7.8.1	Apparatus Required	43
7.8.2	Insulation	43
7.8.3	Heater Current	43
7.8.4	Q Range Accuracy	43
7.8.5	δQ Range Accuracy	44
7.8.6	Q Multiplier Meter Accuracy	44
7.8.7	Tuning Capacitor Calibration Accuracy	44
7.8.8	Indicated Q Accuracy	44
8	COMPONENT LAYOUT ILLUSTRATIONS	
	INTERIOR VIEW FROM REAR	Fig. 8.1
	CAPACITOR UNIT	Fig. 8.2
9	SPARES ORDERING SCHEDULE	SOS 1
10	DRAWINGS	
	Chart of Frequency against Resonating Capacitance for Inductors, Types TM 1438 (Series) and TM 4947 (Series)	Fig. 10.1
	Graphs of Indicated against Effective Resonating Capacitance	Figs. 10.2 and 10.3
	Graph of Resonating-Capacitor Q against Frequency	Fig. 10.4
	Circuit Diagram	Fig. 10.5
	ILLUSTRATIONS IN TEXT	
	1- to 40-kc/s Matching Transformer	Fig. 1.1
	Inductors, Types TM 1438 and TM 4947	Fig. 1.2
	Dielectric and Series Loss Test Jigs, Types TJ 155B/1 and TJ 230	Fig. 1.3
	Controls and Operational Facilities	Fig. 2.1
	Test Jig, Type TJ 230, Fitted for Series Loss Measurements	Fig. 2.2
	Notation	Fig. 3.1
	ϕ and δ Relationship	Fig. 4.1
	Basic Circuit	Fig. 4.2
	Effect of Self Capacitance on Test Circuit	Fig. 4.3
	Graphs of Capacitor Q against Frequency	Figs. 4.4 and 4.5
	Distribution of Test-Circuit Residual Inductance	Fig. 4.6
	Graph of Effective against Indicated Capacitance... ..	Fig. 4.7
	Connectors to Eliminate Lead Inductance of Component Under Test	Fig. 4.8
	L.F. Test Circuit	Fig. 4.9
	H.F. Test Circuit	Fig. 4.10
	Capacitance-Inductance Conversion Chart	Fig. 5.1
	Inductance Measurement Range—Series Method... ..	Fig. 5.2
	Resistance Measurement Range	Fig. 5.3
	Equivalent Circuit of a Transmission Line	Fig. 5.4
	Variation of the Electrical Length of a Transmission Line with Dielectric Constant	Fig. 5.5
	Test Jig, Type TJ 155B/1, Fitted for Dielectric Loss Measurements	Fig. 5.6
	Capacitance of Plate Capacitor due to Uniform Field	Fig. 5.7
	Capacitance of Plate Capacitor due to Fringe Field	Fig. 5.8
	Functional Diagram	Fig. 6.1
	Resonating Capacitor Unit	Fig. 6.2
	Mains Input Arrangements	Figs. 7.1 and 7.2

SCHEDULE OF PARTS SUPPLIED

The complete equipment comprises the following items:—

1. One Instrument, Type TF 1245, complete with attached mains lead and valves, etc., as under:—
 - Valves: One: Type OA2, Voltage Stabilizer.
One: Type 85A2 (5651), Voltage Stabilizer.
One: Type 12AU7, Double Triode.
One: Type EA52, Diode.
 - Semi-conductors: Four: Type CS2A, Silicon Diodes.
One: Type C2D, Selenium Rectifier.
 - Fuses: One: 1-amp, Cartridge, for 190- to 260-volt operation.
or
One: 2-amp, Cartridge, for 95- to 130-volt operation.
One: 150-mA, Cartridge.
 - Lamp: One: 6·3-volt, 0·15-amp, M.B.C., Pilot Lamp.
2. One Inductor Support Platform, TC 28850; for supporting small test components.
3. One Coaxial Lead, TM 5725; for coupling TF 1245 to either TF 1246 or TF 1247 Oscillators.
4. Two Tie Bars, TB 28691; for bonding TF 1245 to either TF 1246 or TF 1247 Oscillators.
5. One Operating and Maintenance Handbook, No. OM 1245.
6. *When specially ordered:* One 1- to 40-kc/s Matching Transformer, Type TM 5728A; Inductors, Types TM 1438 (Series) and TM 4947 (Series); One Series Loss Test Jig, Type TJ 230; One Dielectric Loss Test Jig, Type TJ 155B/1 or TJ 155C/1.

DATA SUMMARY

Frequency Range: 1 kc/s to 300 Mc/s using external oscillators.

Magnification Factor (Q)

RANGES: 5 to 50, 10 to 150, and 60 to 500, with Q multiplier at $\times 1$.

Q MULTIPLIER RANGE: $\times 1$ to $\times 2$.

ACCURACY OF TEST
CIRCUIT Q INDICATION: With the Q multiplier at $\times 1$ and a Q reading of 50, $\pm 5\%$ up to 100 Mc/s, rising to $\pm 12\%$ at 200 Mc/s, and $\pm 20\%$ at 300 Mc/s. At Q readings of 150 and 500, measurement accuracy falls by about 1% from the figures quoted above.

DELTA Q RANGE: 25-0-25.

Nominal Test Circuit Parameters

1-kc/s TO 50-Mc/s TEST

CIRCUIT:

Injection impedance: resistive, 0.02 ohm. Shunt loss: 12 M Ω at 1 Mc/s.

20- TO 300-Mc/s TEST

CIRCUIT:

Injection impedance: inductive, 0.1 m μ H. Shunt loss: 0.3 M Ω at 100 Mc/s.

Tuning Capacitor

(1-kc/s to 50-Mc/s test circuit)

MAIN CAPACITOR: 20 to 500 $\mu\mu$ F; accuracy, $\pm 1 \mu\mu$ F $\pm 1\%$.

INCREMENTAL: 5-0-5 $\mu\mu$ F with 0.2- $\mu\mu$ F increments; accuracy, $\pm 0.2 \mu\mu$ F, above 50 $\mu\mu$ F.

Tuning Capacitor

(20- to 300-Mc/s test circuit)

MAIN CAPACITOR: 7.5 to 110 $\mu\mu$ F; accuracy, $\pm 0.5 \mu\mu$ F $\pm 1\%$.

INCREMENTAL: 1-0-1 $\mu\mu$ F with 0.05- $\mu\mu$ F increments; accuracy, $\pm 0.1 \mu\mu$ F, above 16 $\mu\mu$ F. *The h.f. test circuit capacitor can be used in the l.f. test circuit by external cross-connection.*

Power Supply:

190 to 260 volts, or 95 to 130 volts after adjusting internal links, 40 to 100 c/s. Models supplied ready for 95- to 130-volt use if specified at the time of ordering.

Dimensions and Weight:

<i>Height</i>	<i>Width</i>	<i>Depth</i>	<i>Weight</i>
14 in.	17 $\frac{1}{4}$ in.	9 $\frac{1}{2}$ in.	23 lb.
(36 cm)	(43 cm)	(24 cm)	(10.5 kg)

ACCESSORIES:**Inductors:**

<i>Type</i>	<i>Nominal Inductance</i>	<i>Approx. Magnification</i>	<i>Approx. Self Capacitance</i>	<i>Approx. Frequency Range</i>
TM 1438A	0.2 μ H	200	8 μ F	15– 40 Mc/s
TM 1438B	1.0 μ H	200	8 μ F	8.5– 22 Mc/s
TM 1438P	1.5 μ H	200	8 μ F	6.5– 18 Mc/s
TM 1438C	2.5 μ H	200	8 μ F	5.2– 14 Mc/s
TM 1438D	5.0 μ H	200	8 μ F	3.5–9.0 Mc/s
TM 1438E	10 μ H	200	8 μ F	2.5–6.5 Mc/s
TM 1438F	25 μ H	200	8 μ F	1.6–4.3 Mc/s
TM 1438G	50 μ H	200	8 μ F	1.1–2.9 Mc/s
TM 1438R	75 μ H	200	8 μ F	0.9–2.4 Mc/s
TM 1438H	100 μ H	200	8 μ F	0.8–2.0 Mc/s
TM 1438Q	200 μ H	200	8 μ F	0.6–1.5 Mc/s
TM 1438I	250 μ H	200	8 μ F	0.5–1.3 Mc/s
TM 1438J	500 μ H	160	9 μ F	370–970 kc/s
TM 1438K	1.0 mH	160	9 μ F	270–680 kc/s
TM 1438L	2.5 mH	150	10 μ F	150–410 kc/s
TM 1438M	5.0 mH	130	10 μ F	110–280 kc/s
TM 1438N	10 mH	80	11 μ F	80–220 kc/s
TM 1438O	25 mH	80	11 μ F	50–140 kc/s
TM 4947/1	2.5 μ H	350	4.0 μ F	20– 30 Mc/s
TM 4947/2	0.5 μ H	350	1.5 μ F	25– 70 Mc/s
TM 4947/3	0.05 μ H	300	1.2 μ F	70–230 Mc/s

Dielectric Loss Test Jigs, Types TJ 155B/1 and TJ 155C/1:

RANGE:

Tan δ : 0.001 to 0.07, varying with capacitance of specimen.Resistance: 100 k Ω to 1 M Ω , varying with frequency.ACCURACY: Approx. \pm 5%.

THICKNESS OF SPECIMEN: Up to 0.375 in. (9.5 mm).

ELECTRODES: 1-in. diameter; edges bevelled to minimize fringing.

EQUIVALENT SHUNT LOSS

OF JIGS: About 10 M Ω at 1 Mc/s.**Series Loss Test Jig, Type TJ 230:**

MEASUREMENT RANGE:

Capacitance: 480 μ F to 0.25 μ F.Inductance: 0.005 μ H at 50 Mc/s to 25 mH at 40 kc/s.

Resistance: 0.003 ohm at 50 Mc/s to 1500 ohms at 40 kc/s.

ACCURACY:

Capacitance and

Inductance:

Maximum accuracy of about 4% when C reading changes 2:1.

Resistance:

Maximum accuracy of about 10% when Q of circuit is halved.

1.2.2 INDUCTORS, TYPES TM 1438 (SERIES) AND TM 4947 (SERIES)

A range of 21 inductors, any of which can be supplied separately, is available for use with the Q-Meter. Two basic series are available:

TM 1438 Series—for l.f. test circuit; 18 fully-screened inductors on ceramic formers, fitted with 'banana' plug connectors. Values range from $0.2 \mu\text{H}$ to 25 mH ; each adjusted to within $\pm 3\%$ $\pm 0.05 \mu\text{H}$ of its nominal value. They can be supplied as a complete set, Type TM 4520, in a polished hardwood case.

TM 4947 Series—for h.f. test circuit; three fully-screened inductors fitted with spade-lug connectors.

The inductors available and details of their frequency coverage are given in the Data Summary.

1.2.3 DIELECTRIC LOSS TEST JIGS, TYPES TJ 155B/1 AND TJ 155C/1

These Jigs are primarily designed for the measurement of the dielectric loss of flat specimens of insulating material by the bandwidth-comparison method. They are also suitable for any measurements where small accurately known changes of

capacitance are required, e.g., self-capacitance and r.f. resistance of resistors.

Each unit comprises a precision circular-plate capacitor to contain the sample under test, and a linear-law incremental capacitor by which the bandwidth is determined; adjustment is by micrometer head; the 'B/1' model is calibrated in thousandths of an inch whereas the 'C/1' is in millimetres. Both are mounted on a low-loss ceramic base and the assembly is arranged for attachment to the l.f. test-circuit terminals of the Q-Meter. Each Jig is supplied in a felt-lined wooden case.

1.2.4 SERIES LOSS TEST JIG, TYPE TJ 230

TJ 230 enables the measurement of small values of R and L and large values of C to be made by connecting them in series with the test circuit of the Q-Meter. The unit consists of a printed-circuit base on which are mounted sockets, to accept the TM 1438 series of inductors, and a pair of low-inductance series-connection terminals across which the unknown is connected. The Jig is arranged for connection to the l.f. test circuit terminals of the Q-Meter.

Fig. 1.3 Dielectric and Series Loss Test Jigs, Types TJ 155B/1 and TJ 230.

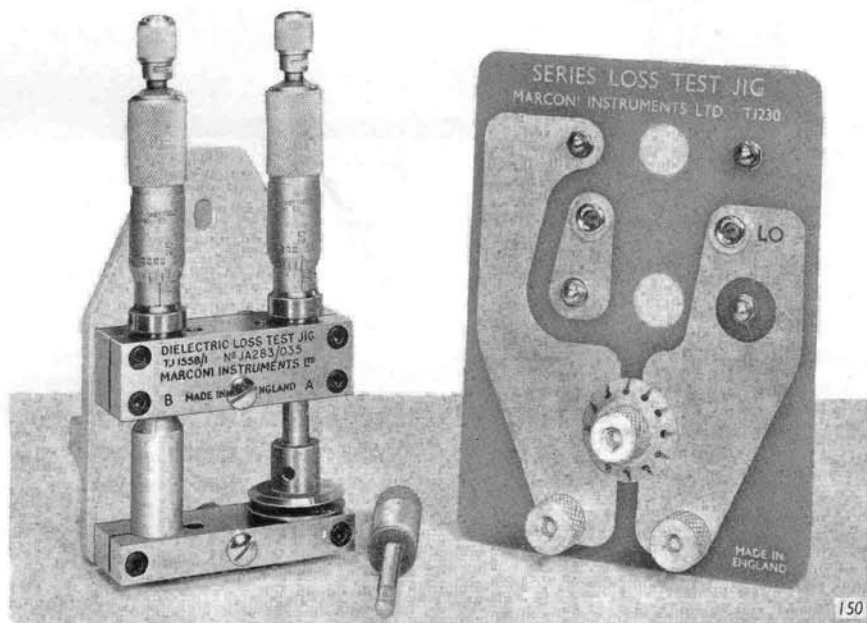

I INTRODUCTION

I.1 GENERAL

The TF 1245 Q-Meter covers the range 1 kc/s to 300 Mc/s. It allows direct measurement of Q-factors from 5 to 1,000; inductance of coils can be readily determined from the test-circuit capacitor reading by means of an attached conversion chart; self-capacitance of coils, inductance and power factor of capacitors, phase angle of resistors, characteristics of transmission lines, and many other quantities can be evaluated by indirect measurements. A delta-Q control facilitates measurements on low-loss insulators and simplifies batch testing.

The Q-indicator and test-circuit section of the Q-Meter is a separate unit energized by one of two specially designed external oscillator units, Types TF 1246 and TF 1247; these have ranges of 40 kc/s to 50 Mc/s and 20 to 300 Mc/s respectively, and one or both can be supplied as required. Below 40 kc/s, an l.f. oscillator such as the Marconi TF 1101 may be used.

Matching units are available to allow the oscillators to be used as general-purpose signal sources.

I.2 OPTIONAL ACCESSORIES

The following items are optional accessories for use with the Circuit Magnification Meter and are supplied only if specially ordered.

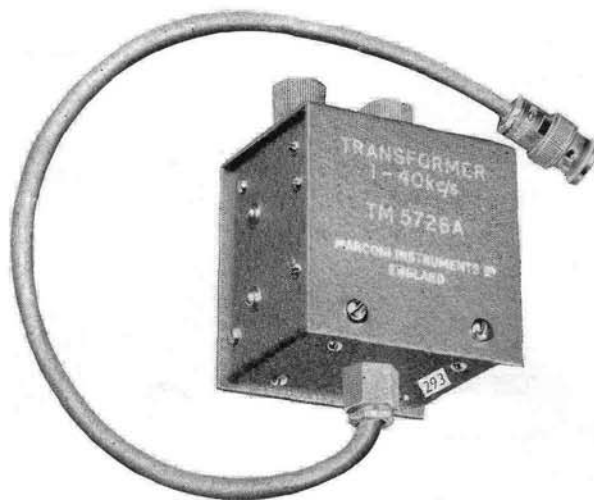

Fig. 1.1. 1- to 40-kc/s Matching Transformer Type TM 5728A.

I.2.1 1 TO 40 kc/s MATCHING TRANSFORMER, TYPE TM 5728A

This is a 600- to 0.5-ohm matching transformer for use from 1 to 40 kc/s. It enables a conventional oscillator to be coupled to the l.f. input of the Q-Meter so that measurements may be made over this lower frequency range.

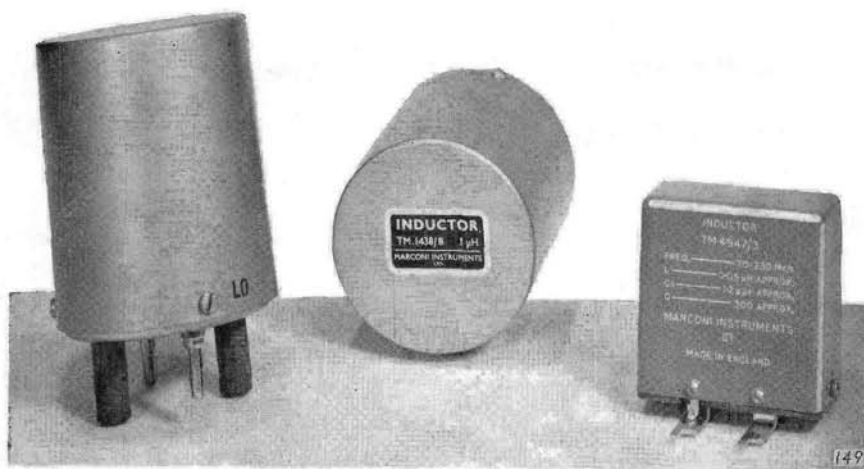
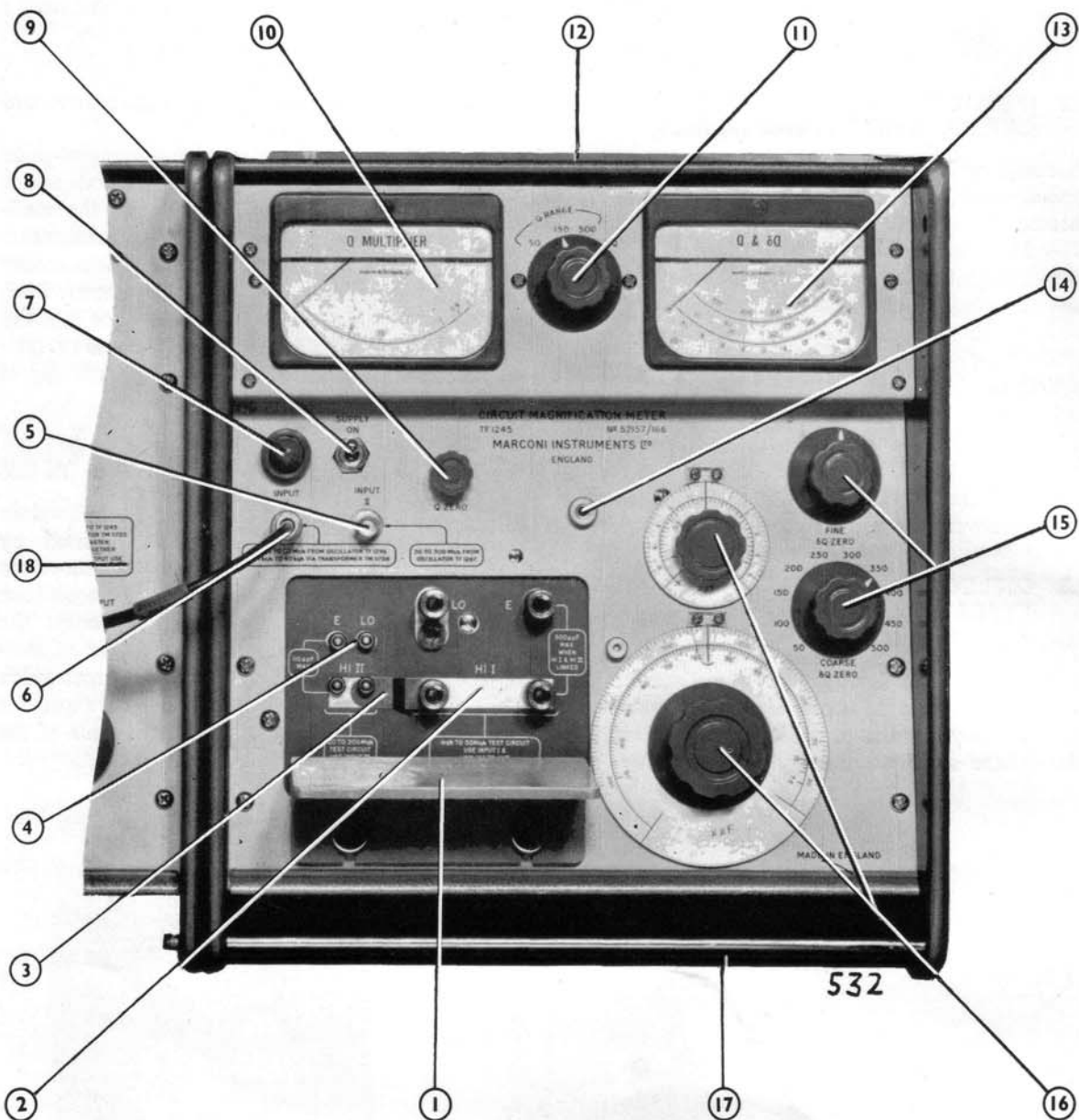

Fig. 1.2 Inductor, Types TM 1438 and TM 4947.



- | | |
|--|---|
| <p>1. Inductor Support Platform</p> <p>2. L.F. Test Circuit</p> <p>3. Link
Join HI I to HI II when using L.F. Test Circuit</p> <p>4. H.F. Test Circuit</p> <p>5. Input II
For H.F. Test Circuit</p> <p>6. Input I
For L.F. Test Circuit</p> <p>7. Pilot Lamp</p> <p>8. Mains Supply Switch</p> <p>9. Q Zero Control
Sets Q and δQ meter zero (d.c. path required between HI II and E terminals)</p> <p>10. Q Multiplier Meter
Multiplying factor applies to both Q and δQ readings</p> | <p>11. Q Range Switch
Selects Q range sensitivity or δQ facility</p> <p>12. Capacitance-Inductance Conversion Chart
Gives direct conversions at set frequencies</p> <p>13. Q and δQ Meter
Direct reading when Q Multiplier reads 1</p> <p>14. Bush
For securing Dielectric Test Jig</p> <p>15. δQ Zero Controls
For backing-off Q reading to δQ centre-zero</p> <p>16. Tuning Capacitor Controls
Incremental control rotates main control to maintain absolute calibration</p> <p>17. Tie Bar (another at the rear)
For bonding TF 1246 or TF 1247 to TF 1245</p> <p>18. Oscillator (TF 1246 shown)
Either TF 1246 or TF 1247 or other oscillator as appropriate; see Section 2.2.1</p> |
|--|---|

Fig. 2.1 Controls and Operational Facilities.

2.4.4 CROSS-CONNECTION BETWEEN CIRCUITS

Over the range 1 kc/s to 50 Mc/s, a combination of both test circuits can be used in order to attain tuning-capacitance values of less than $20 \mu\mu\text{F}$.

To do this: Connect the energizing source to INPUT I; make sure that the HI I and HI II terminals are not linked; and connect the circuit inductor between the LO terminal of the l.f. test circuit and the right-hand HI II terminal. The tuning capacitance range is then 7.5 to $110 \mu\mu\text{F}$.

2.4.5 CONNECTION FOR SERIES MEASUREMENTS

For measurements on low-impedance components (low-value inductors and resistors, high-value capacitors) it is convenient to connect the component in series with the test circuit. This series connection can be achieved in one of two ways: either by making up special connectors for the purpose or, for the l.f. test circuit, by using the Series Loss Test Jig TJ 230.

(a) *General.* The following remarks apply to both test circuits.

The component under test is connected between the test-circuit LO terminal and the low terminal of the circuit inductor. Any simple arrangement of clip leads can be used for this purpose provided it is rigid. The length of the clip leads is not critical as their inductance can be considered as being part of the circuit inductance. In the part of the measurement where the component under test is short-circuited, the shorting strap should be as rigid and robust as possible so that its inductance can be ignored. If this is not possible, its inductance should be calculated (see Section 4.3.6) and correction made to the final result. The main point to remember is that the configuration of the clip-lead circuit should not be allowed to alter during the complete measurement procedure.

(b) *Using the Series Loss Test Jig TJ 230.* For series measurements between 1 kc/s and 50 Mc/s, using the l.f. test circuit, the Series Loss Test Jig can be used. It incorporates a shorting switch, screw terminals for connecting the component

under test, and sockets to accept the inductors of the TM 1438 series.

Before plugging the Test Jig into the l.f. test circuit terminals, make sure that the test circuit LO terminal is screwed into the upper of its two threaded sockets. The four plugs on the jig then locate with the four terminals on the l.f. test circuit. The component under test is connected between the two screw terminals at the base of the jig: the component can be short-circuited by means of the screw switch immediately above these terminals; this switch can, for all practical purposes, be assumed to possess negligible inductance so that no correction is required on this account. The circuit resonating inductor is plugged into the two sockets near the top of the jig, the low terminal of the inductor to the LO socket on the jig.

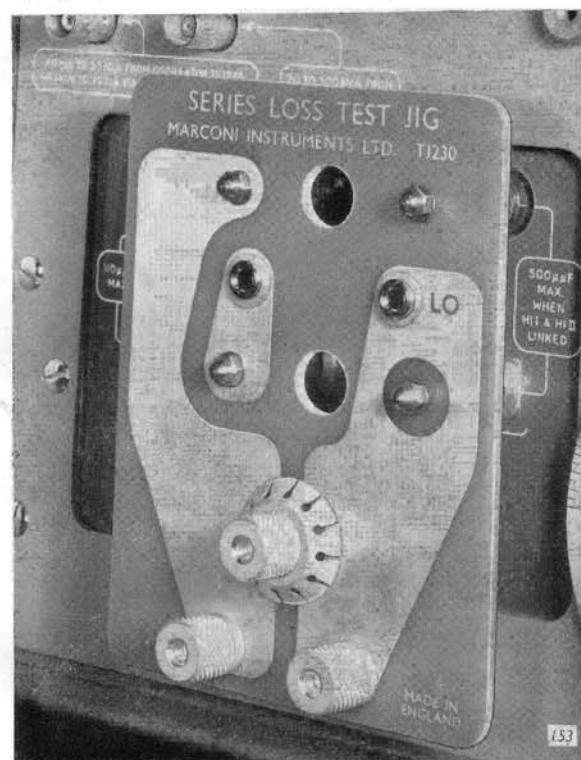

Fig. 2.2 Test Jig, Type TJ 230, fitted for Series Loss Measurements.

2 OPERATION

2.1 INSTALLATION

The TF 1245 is normally despatched ready for operation from mains supply voltages anywhere in the range 190 to 260 volts, but can be adjusted to suit 95- to 130-volt supplies. Before switching on, check the mains transformer tappings or adjust to suit the local supply voltage, as described in Section 7.2.

2.2 SETTING UP

To prepare the Q-Meter for operation, carry out the following procedure:

- (1) Select the oscillator appropriate to the desired test frequency (for further details, refer to Section 2.2.1).
- (2) When using either the TF 1246 or the TF 1247, bond the oscillator and Q-Meter cases by means of the tie-bars supplied with the Q-Meter (for further details, refer to Section 2.2.2).
- (3) Couple the oscillator output to the appropriate Q-Meter input as directed below:—
L.F. Oscillator to INPUT I via MATCHING TRANSFORMER TM 5728A.
TF 1246 Oscillator to INPUT I via LEAD TM 5725.
TF 1247 Oscillator to INPUT II via LEAD TM 5725.
(for further details, refer to Section 2.2.1).
- (4) If in doubt, make sure that the mains input circuits on both the Q-Meter and the oscillator in use are correctly adjusted to suit the particular supply mains to which the instruments are to be connected.
- (5) Check the mechanical zeros of the Q-Meter meters and adjust if necessary.
- (6) Set the oscillator output level control to its minimum-output position, and the Q-Meter Q RANGE switch to 500.
- (7) Connect both instruments to the supply mains and switch on; the pilot lamps should now glow.
- (8) If required, mount the plastic Inductor Support Platform, TC 28850, on the front panel. It is held by the two captive, knurled-head screws below the test-circuit panel.

2.2.1 OSCILLATOR SELECTION

Over the Range 1 to 40 kc/s, any 600-ohm l.f. oscillator may be used, provided it will give an output of about 22 volts (0.8 watt). This input level is that required for the Q-Meter Q MULTIPLIER to read at its $\times 1$ mark. The Q MULTIPLIER is calibrated over the range $\times 0.9$ to $\times 2$; therefore, if the oscillator available is not capable of giving this output, the input level may be set to a lower datum, for example $\times 2$, when approximately 11 volts will be required, and valid measurements can still be made.

The oscillator must always be connected to INPUT I and via the optional 1- to 40-kc/s MATCHING TRANSFORMER TM 5728A. The coaxial plug on the unit is coupled direct to INPUT I, and the oscillator output to the screw terminals on the unit.

The Marconi Oscillator recommended for this application is:—

R-C Oscillator, TF 1101.

The following Marconi Oscillators are also suitable:—

Beat Frequency Oscillator, TF 195 series*

Video Oscillator, TF 885 series†

Audio Tester, TF 894 series

* Certain versions of the TF 195 series have a 50-ohm output impedance and a maximum output level of 10 volts and, therefore, are not suitable for this application. All the basic models in the range, however, are suitable.

† At 22-volts output level, the TF 885 oscillators have an output impedance of 1000 ohms. The resultant mismatch is not sufficient to affect the operation of the Q-Meter.

Over the Range 40 kc/s to 20 Mc/s, use the Marconi Oscillator TF 1246. It must be connected to INPUT I via the special LEAD TM 5725 supplied with the Q-Meter.

Over the Range 20 to 50 Mc/s, use either the TF 1246 or TF 1247 Oscillators as convenient. Above about 20 Mc/s, measurement errors due to the magnitude of the l.f. test circuit injection resistance (0.02 ohm) can tend to become significant. If both oscillators are available, and tuning capacitances exceeding 110 $\mu\mu\text{F}$ are not envisaged, it is preferable to use the 20- to 300-Mc/s Oscillator TF 1247.

The TF 1246 must be connected to INPUT I and the TF 1247 to INPUT II; both must be coupled via the special LEAD TM 5725 supplied with the Q-Meter.

Over the Range 50 to 300 Mc/s, use the Marconi Oscillator TF 1247. It must be connected to INPUT II via the special LEAD TM 5725 supplied with the Q-Meter.

2.2.2 BONDING THE OSCILLATORS

If the Oscillator and Q-Meter are not bonded together, a tuned circuit will exist between them. It will comprise (i) the capacitance between the adjacent side plates of the two instruments and (ii) the inductance of the outer screen of the connecting LEAD TM 5725. At certain frequencies, particularly in the range 30 to 70 Mc/s, the resultant magnetic field set up can have a very marked effect on measurement accuracy due to its interference with the field set-up by the Q-Meter test circuit.

Therefore, to eliminate these spurious effects, the TF 1246 and TF 1247 Oscillators should be bonded to the Q-Meter by means of the tie-bars supplied with the Q-Meter.

The tie-bars are located at the top-rear and bottom-front of the instrument. They pass through both side plates of the Q-Meter and screw into two threaded bushes in the right-hand side plate of the Oscillator. The bars are held captive to the Q-Meter by means of rubber grommets which fit into slots on the bars.

2.2.3 INITIAL MEASUREMENTS

On first taking delivery of a TF 1245 Q-Meter it is good practice, though not essential, to take a set of readings of Q and capacitance using the Marconi Inductors TM 1438 series and TM 4947 series. The results obtained can then be tabulated and filed for future reference. A set of data is thereby always available for comparison purposes in the event of re-calibration or other maintenance work being required.

It should be remembered that these inductors are intended as test-circuit-resonating inductors for general measurements and not as high-precision inductance standards. The conditions existing at the time of measurement can have some effect on the inductance, self-capacitance, and Q readings obtained; for example, change in ambient temperature will have some effect on the ohmic resistance of the inductor and hence on its Q value. In general, the long-term measurement repeatability will be of the order of $\pm 10\%$ at the lower frequencies, decreasing somewhat at the higher frequencies.

2.3 BASIC Q-MEASUREMENT PROCEDURE

The following sections, 2.3.1 to 2.3.5 describe in general terms the Q-measurement procedure; they are intended as a guide for those not familiar with Q-Meter techniques and as a reminder for the experienced operator.

The user should be fully acquainted with the information given in the following sections before proceeding to the detailed measurement and calculation procedures given in Section 5.

2.3.1 SETTING ZERO

Before commencing a measurement, it is essential that the electrical zero of the Q AND δQ meter should be accurately set by carrying out the procedure described below. Where the highest order of measurement accuracy is required, the zero setting should be checked immediately prior to making each measurement.

It should be remembered that, because a series-connected voltmeter diode is used, there should always be a d.c. path between the HI and E terminals otherwise the Q ZERO control will not have any effect on the meter deflection. This d.c. path is, of course, usually provided via an inductor connected to the HI and LO terminals.

- (1) Short-circuit the HI and E terminals on the h.f. test circuit.
- (2) Set the Q RANGE switch to 50.
- (3) Adjust the Q ZERO control to bring the Q AND δQ meter to the left-hand zero mark.
- (4) Set the Q RANGE switch to 500 and remove the short-circuit from the HI and E terminals.

2.3.2 MAKING A MEASUREMENT

Having set zero as described above, the general procedure for making a measurement is as follows:—

- (1) Select the required test frequency,
- (2) Connect the component under test (see Section 2.4).
- (3) Adjust the oscillator output level control to bring the pointer of the Q MULTIPLIER meter to its $\times 1$ mark. In cases where the parameters of the component under test are liable to vary with respect to the applied voltage, a different level setting may be required; this is dealt with fully in Section 2.3.3.
- (4) Tune to resonance—as indicated by maximum deflection on the Q AND δQ meter—by means of the tuning capacitor control. If necessary, restore the Q MULTIPLIER reading to the $\times 1$ mark.

- (5) Adjust the Q RANGE setting, as necessary, to obtain a convenient reading on the Q AND δQ meter.
- (6) Read the Q value of the test circuit from the appropriate Q AND δQ meter scale; perform any necessary multiplication as indicated by the reading of the Q MULTIPLIER meter.

Note: *Hand capacitance effects will be noticed when coils of large diameter and high Q value are in use. While such effects cannot be entirely eliminated, except by elaborate screening, comparatively consistent results may be obtained by adopting similar procedures in all measurements.*

2.3.3 USE OF THE Q MULTIPLIER METER

The calibrated Q MULTIPLIER meter, in conjunction with the output level control, provides a means of controlling the amplitude of the voltage developed across the component under test. This facility, primarily intended for measurements on components whose permeability or permittivity varies with applied voltage, may be utilized in two ways as described below.

- (1) The effect of varying the voltage developed across a component at resonance can be investigated; for example, variation of inductor inductance with applied voltage.

The Q AND δQ meter serves as an indicator of relative voltage across a component under test at resonance; the voltage at resonance can be halved, for instance, by reducing the output level control until the Q AND δQ meter reading falls by half. At each setting the Q factor is determined by multiplying the reading on the Q AND δQ meter by the factor indicated by the Q MULTIPLIER.

It will be appreciated that if the initial measurement is made with the Q MULTIPLIER at $\times 1$, the applied voltage can only be reduced.

For absolute voltage indication the Q AND δQ meter reading can be used since the meter reading corresponds to 1 volt per 50 Q.

- (2) The resonant voltage can be maintained constant while other parameters are assessed; for example, the extent to which the dissipation factor of a capacitor varies with frequency can be observed independently of the effect of voltage change.

The resonant voltage can be maintained constant by readjusting the output level control at each successive measurement in order to maintain the same reading on the Q AND δQ meter at resonance.

The Q value is determined by multiplying the reading on the Q AND δQ meter by the factor indicated by the Q MULTIPLIER. Since there will be a different Q MULTIPLIER meter reading at each measurement it is generally advisable to make the first of a series of measurements with the Q MULTIPLIER reading at about mid-range, that is, 1.5.

2.3.4 USE OF δQ FACILITY

For some types of measurement, an accurate knowledge of change in Q as well as absolute Q is required: an example of this is bandwidth determinations on low-loss components. If the change is small, it is difficult to read the Q difference accurately on the normal meter scales because of the inherently low incremental accuracy. To overcome this, switching is incorporated within the instrument so that any portion of the Q range above 50 Q can be expanded.

This expanded scale is calibrated from $-25 Q$ to $+25 Q$ and is direct-reading when the Q MULTIPLIER reads at its $\times 1$ mark. Readings obtained from this expanded $-\delta Q$ scale are subject to any multiplication factor indicated by the Q MULTIPLIER meter.

To make use of the δQ scale:

- (1) Resonate the test circuit in the normal manner.
- (2) Note the Q reading.
- (3) Set the COARSE δQ ZERO switch to the nearest position below the indicated Q AND δQ meter reading, ignoring any Q MULTIPLIER factor.
- (4) Set the Q RANGE switch to δQ and adjust the FINE δQ ZERO control until the Q AND δQ meter reads at the centre zero mark on the δQ scale.
- (5) Make the required change in the measurement condition, check resonance where appropriate, and note the new Q reading.

If the change in Q exceeds the half-scale coverage, and it is known that the change will always be in the same direction, it is permissible to adjust the FINE δQ ZERO so that the Q AND δQ meter reads at one or other of its full-scale marks.

An extension of the δQ scale should not be made by altering the setting of the COARSE δQ ZERO control after the FINE δQ ZERO has been adjusted.

It is recommended that whenever the operator is making a measurement involving a knowledge of change in Q, the δQ facility should be used, where possible, in order to obtain maximum discrimination.

2.3.5 USE OF δC FACILITY

In addition to the main tuning capacitor control, an incremental-capacitor control is fitted to enable small, accurately known changes of capacitance to be made. It is calibrated from -5 to $+5 \mu\mu\text{F}$ for the l.f. test circuit capacitor, and from -1 to $+1 \mu\mu\text{F}$ for the h.f. test circuit capacitor. A slipping clutch mechanism permits rotation of the incremental dial relative to the main dial so that the '0' can be set to the incremental-dial cursor line at any position of the main dial. Rotation of the incremental dial alters the setting of the main dial so that the main dial is always direct reading: rotation of the main dial does not affect the incremental-dial setting.

- (1) *To alter the tuning capacitance by a known amount:* set the incremental dial to its central, zero position; adjust the main control to obtain resonance; then use the incremental control to advance or retard the capacitance by the required amount.
- (2) *To set the tuning capacitance to a known value:* set the incremental dial to its central, zero position; adjust the main control to bring the dial to the calibration point which indicates the capacitance nearest to that required; then advance or retard the incremental dial to bring the main dial to the required capacitance.

When measurements are made using an incremental-capacitance method of determining Q , the condition arises in which the circuit is deliberately detuned from resonance with the result that the load presented to the oscillator will vary slightly. This may have the effect of pulling the oscillator frequency slightly. In the great majority of cases, this slight change of oscillator frequency will not matter and can be ignored. Where the highest possible measurement accuracy is required, the operator may find it desirable to monitor the frequency and restore it to the value at resonance if any shift occurs when the test circuit is detuned. The monitoring can be achieved by coupling a crystal calibrator very loosely into the test circuit.

2.4 CONNECTION OF TEST COMPONENTS

2.4.1 GENERAL

Two test circuits are incorporated in the TF 1245; the l.f. test circuit (right-hand set of terminals) is used for measurements in the range 1 kc/s to 50 Mc/s; the h.f. test circuit (left-hand set of terminals) is used for the 20- to 300-Mc/s range.

When the energizing source is connected to INPUT I, use the right-hand (large) set of terminals; when the energizing source is connected to INPUT II, use the left-hand (small) set of terminals. The exception to this rule is described in Section 2.4.4.

The exact method by which a component is connected to the appropriate test circuit depends (a) on the type of component, (b) on the type of measurement, and (c) on whether any auxiliary apparatus is used. In general, an inductor is connected between LO and the HI terminal immediately below, and a capacitor between E and the HI terminal immediately below. The individual methods of connecting a component are specified in the Sections which deal with the different types of measurement that can be made with a TF 1245.

The distribution of the residual components of the various combinations of test circuit is shown in Figs. 4.9 and 4.10 on page 23.

2.4.2 L.F. TEST CIRCUIT

Interconnect the HI I and HI II terminals by means of the link provided.

Screw the LO terminal into either of its threaded sockets to suit the inductor in use. This terminal is provided with alternative positions so that both Marconi-pattern and US-type Inductors may be used. If the inductor is wire ended, it will probably be more convenient to screw the terminal into the lower of its two sockets in order to reduce lead length to a minimum.

The internal tuning capacitance that exists between the HI I and E terminals is variable over the range 20 to 500 $\mu\mu\text{F}$ with an incremental variation of -5 to $+5 \mu\mu\text{F}$ above 50 $\mu\mu\text{F}$. Tuning capacitance is read on the outer arcs of the dials. The incremental dial is linked to the main dial by a slipping-clutch mechanism so that the main dial is always direct reading regardless of the setting of the incremental dial.

2.4.3 H.F. TEST CIRCUIT

Make sure that the HI I and HI II terminals are *not* linked.

The terminal spacing of the test circuit is such that both Marconi-pattern and US-type Inductors can be used.

The internal tuning capacitance that exists between the HI II and E terminals is variable over the range 7.5 to 110 $\mu\mu\text{F}$ with an incremental variation of -1 to $+1 \mu\mu\text{F}$ above 16 $\mu\mu\text{F}$. Tuning capacitance is read on the inner arcs of the dials. The incremental dial is linked to the main dial by a slipping-clutch mechanism so that the main dial is always direct reading regardless of the setting of the incremental dial.

3 OPERATIONAL SUMMARY

Once the user is familiar with the principles and techniques of operation detailed in Section 2, the following abridged instructions may be found convenient.

SETTING UP

Select the appropriate oscillator and connect to the correct INPUT socket:—

- (i) 1 to 40 kc/s — 600-ohm l.f. oscillator via MATCHING TRANSFORMER TM 5728A to INPUT I.
- (ii) 40 kc/s to 50 Mc/s — Marconi OSCILLATOR TF 1246 via LEAD TM 5725 to INPUT I.
- (iii) 20 Mc/s to 300 Mc/s — Marconi OSCILLATOR TF 1247 via LEAD TM 5725 to INPUT II.

BEFORE SWITCHING ON

- (1) Check that the power transformers of the Oscillator and Q-Meter are correctly adjusted.
- (2) Bond the Oscillator, if TF 1246 or TF 1247, to the Q-Meter with the tie-bars.
- (3) Set the mechanical zero of the TF 1245 meters.

SETTING ZERO

- (1) Short-circuit HI II and LO terminals.
- (2) Adjust Q ZERO control on 50 Q RANGE.
- (3) Remove short-circuit.

CONNECTIONS

For L.F. Test Circuit (1 kc/s to 50 Mc/s):—

- (1) Link HI I and HI II terminals for 20- to 500- $\mu\mu\text{F}$ tuning capacitance.
- (2) Use right-hand (*large*) terminals.
For series measurements use Series Loss Test Jig TJ 230.
- (3) For 7.5- to 110- $\mu\mu\text{F}$ tuning capacitance remove link, connect inductors between HI II and l.f. LO terminals.

For H.F. Test Circuit (20 to 300 Mc/s):—

- (1) Remove link between HI and HI II terminals; tuning capacitance 7.5 to 110 $\mu\mu\text{F}$.
- (2) Use left-hand (*small*) terminals.

MAKING A MEASUREMENT

- (1) Select the test frequency.
- (2) Connect component under test.
- (3) Adjust oscillator output level to give $\times 1$ on Q MULTIPLIER meter (or as required).
- (4) Tune to resonance — indicated by maximum deflection on Q AND δQ meter—by means of tuning capacitor controls.
- (5) Q value given by Q AND δQ meter reading multiplied by Q MULTIPLIER meter reading.
- (6) To use δQ scale—set COARSE δQ ZERO switch to nearest value below Q AND δQ meter reading, switch Q RANGE switch to δQ and adjust FINE δQ ZERO control to give zero on δQ meter-scale.

NOTATION

Fig. 3.1

MEASUREMENTS ON INDUCTORS, CAPACITORS, AND RESISTORS

C_A	= Absolute capacitance value of a capacitor under test.
C_E	= Effective circuit resonating capacitance
C_{ind}	= Reading on the tuning capacitance dial In all substitution measurements, the term C_1 refers to the indicated reading with the test component out of circuit, while the term C_2 refers to the reading with the test component connected
C_O	= Self-capacitance of the circuit inductor
C_P	= Combined self-capacitance of two inductors in series
C_X	= Effective capacitance value of a capacitor under test
f	= Frequency
f_0	= Natural (self-resonant) frequency of a component under test
L_O	= Self-inductance of a component under test
L_R	= Residual inductance of the test circuit
L_S	= Inductance of a flat strip
L_W	= Inductance of any leads directly associated with a component under test
L_X	= Effective series inductance of an inductor under test
Q_A	= Absolute Q of an inductor under test
Q_C	= Q of the test-circuit capacitor
Q_{ind}	= Reading on the Q AND δQ meter In all substitution measurements, the term Q_1 refers to indicated readings with the test component out of circuit, while the term Q_2 refers to the reading with the test component connected
R_P	= Shunt resistance of the circuit capacitor
R_R	= Residual resistance of the test circuit
R_X	= Effective series resistance of a component under test
R_{XP}	= Effective shunt resistance of a component under test
$\tan \delta_X$	= Phase defect of a component under test
X_{CT}	= Total capacitive reactance of the test circuit

MEASUREMENTS ON TRANSMISSION LINES

A	= Attenuation of the line
C_d	= Effective short-circuit shunt capacitance of the line
G_d	= Effective short-circuit shunt conductance of the line
k	= Dielectric constant of the transmission line insulator
L_s	= Effective open-circuit series inductance of the line
R_s	= Effective open-circuit series resistance of the line
S	= Physical length of the line
Z_0	= Characteristic impedance of the line
λ	= Wavelength in the transmission line
λ_0	= Free-space wavelength

4 Q-METER THEORY

4.1 DEFINITION OF Q AND TAN δ

The symbol 'Q' indicates the quality of a component or system and is equal to 2π times the ratio of energy stored to energy lost per cycle. Numerically it is the ratio of reactance to resistance at the frequency of test

$$Q = \frac{X}{R} = \frac{2\pi fL}{R} = \frac{1}{2\pi fCR} \quad (1)$$

The reciprocal $\left\{\frac{1}{Q}\right\}$ is not strictly the 'power factor'. Power factor is the ratio of true power to apparent power in a system and is represented by the cosine of phase angle ϕ , that is, the angle between the current and voltage vectors. In other words, $\cos \phi$ is the ratio of resistance to impedance, not to reactance. It is the tangent of the complementary angle— δ —which represents the ratio of resistance to reactance, $\tan \delta$ is known by various names, such as dissipation factor 'D,' phase defect, and loss tangent. Although it is true to say that $\cos \phi$ and $\tan \delta$ are for all practical purposes numerically equal for Q values greater than about 10, it is important that the lack of equality should be borne in mind when referring to the dissipation factor of a component by the technically incorrect, but generally used, term 'power factor'

$$\tan \delta = \frac{R}{X} \quad \cos \phi = \frac{R}{Z}$$

$$\tan \delta \simeq \cos \phi \text{ for } \tan \delta < 0.1$$

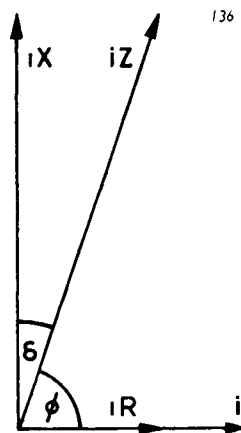

Fig 4.1 ϕ and δ Relationship

OM 1245
2-4/68

4.2 BASIC CIRCUIT ARRANGEMENTS

Consider a simple series-resonant circuit as shown in Fig 4.2. An e m f of amplitude e is injected at the resonant frequency f . The current through the

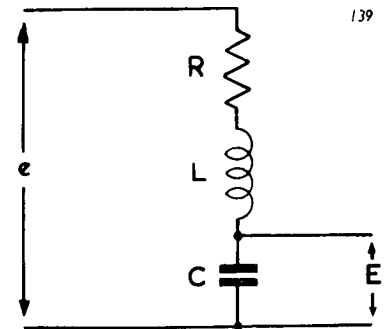

Fig 4.2
Basic Circuit

circuit at resonance is equal to $\frac{e}{R}$ where R is the total circuit resistance. The e m f developed across the inductance— iX_L which, at resonance, $= iX_C$

The magnification of the complete circuit, from equation (1)

$$= \frac{X}{R} = \frac{iX}{iR}$$

From this it can be seen that Q equals the ratio of the developed e m f, across one or other of the reactances at resonance, to the injected e m f, that is

$$Q = \frac{E}{e} \quad (2)$$

Hence, if e is maintained at a constant, known level, a conventional voltmeter can be connected across the circuit capacitor and can be calibrated directly in terms of circuit Q .

It should be remembered that the resistance R is the total a c circuit resistance at the frequency of test and is not the resistance associated directly with the component under test. Thus the measured Q is not that of any particular component in the circuit but is that of the complete circuit.

The circuit resistance can be considered as being of two forms—series and shunt. It is substantially correct to assume that all series resistance is in series with the circuit inductance and that all shunt resistance is in parallel with the circuit capacitance. The total Q (Q_T) of the circuit can then be expressed as —

$$\frac{1}{Q_T} = \frac{1}{Q_L} + \frac{1}{Q_C} \quad (3)$$

where Q_T = the magnification of the complete circuit

Q_L = the magnification of the inductive part of the circuit

$$= \frac{\omega L}{R_L} \quad (L = \text{the total effective series inductance})$$

R_L = the total effective series resistance)

Q_C = the magnification of the capacitive part of the circuit

$$= \omega C R_P \quad (C = \text{the total effective series capacitance})$$

R_P = the total resistance in parallel with the capacitance)

To obtain a true measure of the quality of a component rather than the quality of the complete circuit, it is necessary to have a knowledge of the residual 'error' resistances and reactances of the circuit. Do not forget, of course, that in a properly designed circuit the residuals are of very small magnitude and can be ignored for most measurements. On this basis, the measured ratio E_e can then be taken to be the Q value of the component under test.

The preceding remarks are all based on theoretical considerations. The following section deals with the practical aspects of such a circuit and the ways in which residual components can affect measurement accuracy.

4.3 CORRECTIONS

Theoretically, a Q -Meter measures the Q of the complete circuit, this would be true if the circuit inductor were perfect and possessed no self-capacitance. The true Q of the circuit will always be greater than that indicated by the Q -measuring device by a factor dependent on the relative values of the self-capacitance and the main circuit capacitance. The reason for this is explained in Section 4.3.1.

In general, the operator is not interested in the complete circuit but in the constants of a particular part of that circuit—that is, the component under test. Once the true Q of the complete circuit has been determined, it remains to separate the constants of the component under test from those of the remainder of the circuit. Sections 4.3.2 to 4.3.6 discuss these circuit constants and the ways in which they can be used to obtain the required result.

4.3.1 SELF-CAPACITANCE OF CIRCUIT INDUCTOR

Probably the most important factor affecting measurement accuracy, and the one most often overlooked, is the self-capacitance of the test component. In the preceding sections it has been assumed, quite correctly, that the test circuit is purely a series arrangement (remember that the capacitor shunt resistance R_P can be expressed as a series element but that it simplifies calculations to make use of the shunt value). When making measurements on a test component that is largely inductive but includes some self-capacitance, it is no longer correct to consider the circuit as a purely series arrangement. This is because the self-capacitance, which acts as part of the total tuning capacitance, is an element in parallel with the test inductance (Fig. 4.3 shows the effective circuit).

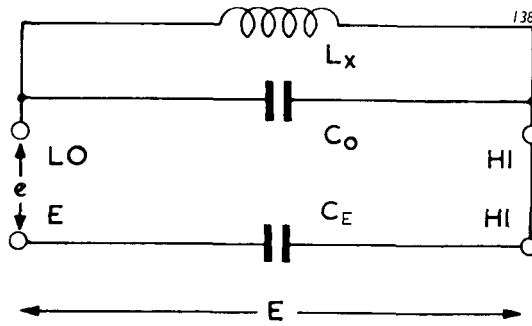

Fig. 4.3 Effect of Self-Capacitance on Test Circuit

The total effective resonating capacitance is not due wholly to the permanent circuit capacitance (C_E) but is affected by the self-capacitance of the test component. As a result, the voltage developed across C_E is not the total voltage developed across the circuit capacitance but is less than that total by the ratio

$$\frac{C_E}{C_E + C_0}$$

From this, the true Q of the circuit is given by the expression

$$Q_T = Q_{ind} \left\{ 1 + \frac{C_0}{C_E} \right\} \quad (4)$$

where Q_{ind} is the indicated Q reading

4.3.2 CIRCUIT CAPACITOR LOSSES

In the conventional Q -Meter, the measuring device is connected across the circuit capacitor. The capacitor will be shunted with resistance of finite value derived from two sources: first, that due to the input resistance of the measuring device, and second, that of the capacitor insulation resistance itself. By careful design and layout of

components it is sufficiently accurate to express the two components as a single resistance directly in parallel with the capacitor plates. This means that the circuit capacitor and its loss component can be disassociated from any residual circuit inductance (discussed in Section 4.3.3) a fact which simplifies calculations considerably.

Transposing expression (3), the Q of an inductor under test is given by

$$Q_L = Q_T \left(\frac{1}{1 - \frac{Q_T}{Q_C}} \right) \quad (5)$$

where Q_T = the magnification of the complete circuit

Q_C = the magnification of the capacitive part of the circuit

Thus, provided Q_C is very large compared with Q_T , no correction need be applied.

The effect that the shunt resistance will have on measurement accuracy can be divided into two categories for simplicity of explanation: the effect at h f and the effect at l f.

Although a very high value of shunt resistance can be attained, 12MΩ at 1 Mc/s is typical, its value will decrease appreciably with increase in frequency to, say, 50 kΩ at 300 Mc/s, but it can be seen from Fig 4.5 that the resultant values of Q_C still, for all practical purposes, approach infinity.

At frequencies below about 100 kc/s, the shunt resistance will approach a limiting value dependent on the constants of the diode circuit, numerically, the shunt resistance at l f is typically 50 MΩ. As the limiting value is approached, Q_C becomes directly proportional to frequency for a fixed value of capacitance as is shown in Fig 4.4. It will also be noticed that Q_C drops to a low value at 1 kc/s. Bear in mind that, although Q_C appears low, its shunt impedance is still considerably greater than that of practically any circuit into which the component under test may eventually be connected.

From expression (5) it is implied that a considerable correction would be necessary. In practice this is not so because, in an l f circuit, a large value of tuning capacitance is used in order to obtain maximum circuit Q. As a result, the correction is usually negligible.

4.3.3 RESIDUAL INDUCTANCE

Regardless of how substantial the elements connecting one part of the test circuit to another are made, they will still possess a certain residual inductance. This inductance will be distributed around the circuit but can be lumped into two components whose effective positions in the circuit are as shown in Fig 4.6.

L1 is the inductance that exists between the capacitor H1 and E terminals, L2 is that attributed to the remainder of the circuit.

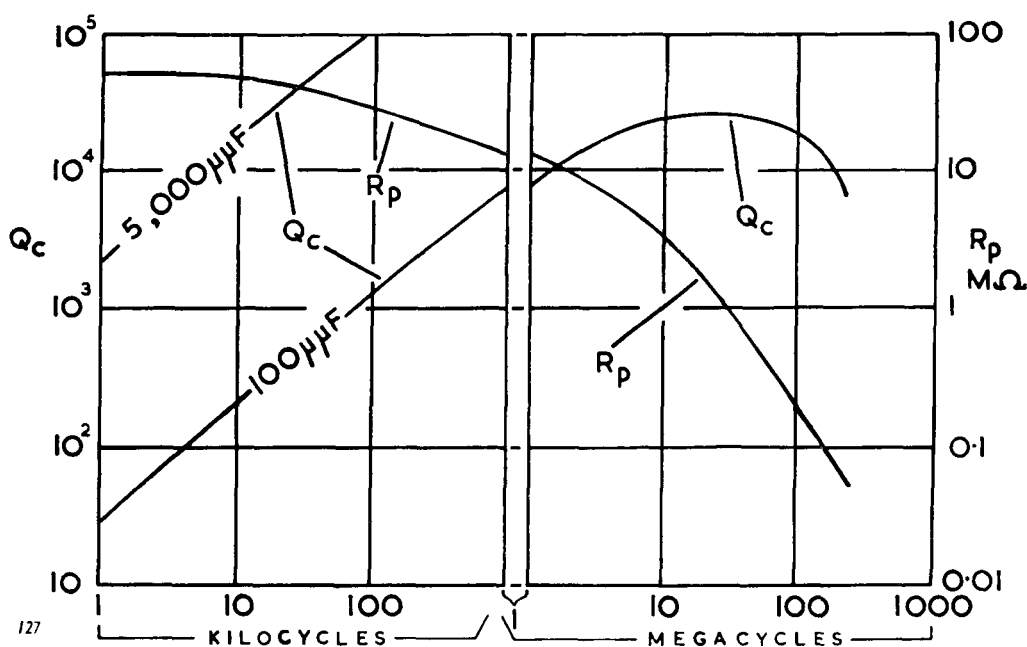

Fig 4.4

Fig 4.5

Graphs of Capacitor Q against Frequency

From Fig 4.6 it will be seen that the effective capacitance that resonates with a test inductance (L_x) will depend on the value of the residual inductance. Depending on the type of measurement, this inductance can be considered in two ways —

(i) For Q and inductance measurements (that is, measurements in which the test component is connected across the HI and LO terminals), it is usual to combine the residual inductance with the inductance of the test component. The resonating capacitance is then indicated directly by the tuning capacitor dial (C_{ind}). Q_L is then given by the expression

$$Q_L = Q_T \left\{ \frac{1}{1 - \frac{L_1 + L_2}{L_x}} \right\} \quad (6)$$

$$\text{and } L_x = \frac{1}{\omega^2 C} - (L_1 + L_2) \quad (7)$$

Generally, if $L_1 + L_2$ is small compared with L_x , these corrections can be ignored.

(ii) For capacitance measurements (that is, measurements in which the test component is connected across the circuit capacitor) a knowledge of the effective capacitance that exists between the HI and E terminals is usually required. The effective tuning capacitance (C_E) is given by the expression

$$C_E = C_{ind} \frac{1}{1 - \omega^2 L_1 C_{ind}} \quad (8)$$

At large values of capacitance at high frequencies, this correction can become very significant. A typical graph of C_E against C_{ind} is shown in Fig 4.7.

4.3.4 INJECTION IMPEDANCE

Ideally, the injection e.m.f. should be developed across an impedance of zero magnitude in practice, this is obviously not possible. The nearest approximation is either a very small pure reactance or resistance.

A close approximation to a pure reactance can be achieved by using an inductance of very low value, if the value is made small enough, any associated resistance and self-capacitance can be neglected. Inductive injection is generally used above about 20 Mc/s because of its negligible resistive loading on the resonant circuit. This system of injection functions extremely well at v.h.f., but as frequency is reduced, the current required to develop the constant-level injection e.m.f. increases and, eventually, reaches unpractical proportions. Assuming there are no other sources of error, the magnitude of the injection inductance will cause the measured Q (Q_T) to be greater than the true Q (Q_L) of an inductor. Q_L can be expressed as

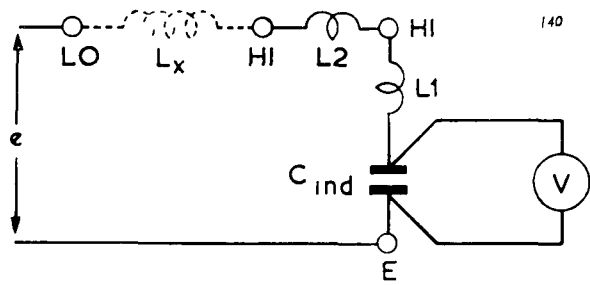

Fig 4.6 Distribution of Test Circuit Residual Inductance

$$Q_L = Q_T \left\{ \frac{1}{1 - \frac{L_1}{L_L}} \right\} \quad (9)$$

where L_L = the inductance of the circuit inductor and L_I = the injection inductance.

In general, no significant Q error is introduced from this cause because L_I is always much less than any test inductance, even at the highest frequencies.

To enable a Q-Meter to operate down to audio frequencies, it would be necessary to change the value of injection inductance a number of times in order to satisfy the oscillator-current limitation mentioned above. Because low-frequency test circuits include significant effective series resistance, it is convenient and practical to utilize a non-inductive resistor—such as a disk resistor—of very low value. This system of injection can be used below about 50 Mc/s. Assuming there are no other sources of error, the magnitude of the injection resistance will cause the measured Q (Q_T) to be less

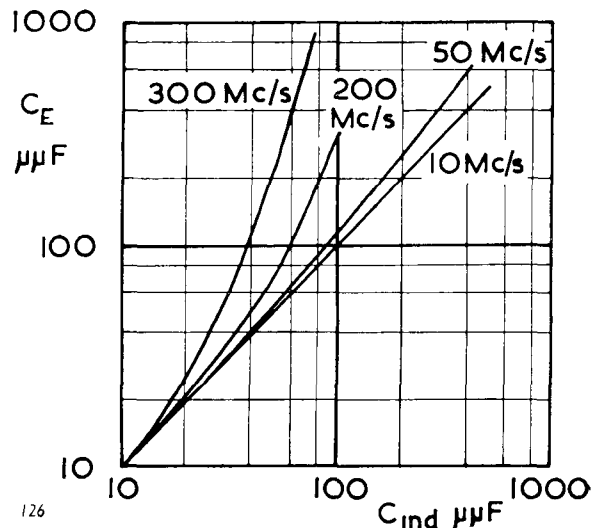

Fig 4.7 Graph of Effective Capacitance against Indicated Capacitance

than the true Q (Q_L) of an inductor Q_L can be expressed as

$$Q_L = Q_T \left\{ 1 + \frac{R_I}{R_L} \right\} \quad (10)$$

where R_L = the circuit resistance
and R_I = the injection resistance

In general, except at the highest frequencies, R_I is always much less than the effective resistance of the resonant circuit and, therefore, can be ignored

4.3.5 VOLTMETER RESONANCE AND TRANSIT TIME

In order to make the circuit capacitor shunt resistance as high as possible, it is usual to employ a diode valve voltmeter as the Q -measuring device. The diode can be either series or shunt connected, series connection yields the higher input impedance. Regardless of the type of valve voltmeter used, however, measurement errors can be introduced because of transit time effect and frequency response. The reasons for and results of these effects are already well known but are summarized here for completeness.

Transit time errors are brought about by the fact that electrons in a diode take a finite time to travel from cathode to anode. If the transit time is short compared to the period of the applied signal, no error results. If the transit time is comparable, the diode conducting period is too short, resulting in the voltmeter reading low. This effect only applies at low inputs since transit time decreases proportionally with increase in applied level.

The frequency response, and hence the measurement accuracy, of a diode voltmeter drops at very low frequencies due to the increasing impedance of the diode load capacitor. At very high frequencies, the response is subject to the natural resonance of the diode input circuit.

Both types of effect could introduce serious measurement errors if not properly controlled, but modern design techniques, including the use of planar, low-capacitance diodes, have enabled the possibility of error from these causes to be reduced to negligible proportions over the full 1-kc/s to 300-Mc/s range.

4.3.6 CONNECTING LEAD INDUCTANCE

It will be appreciated that a measured result will include the effect due to all resistive and reactive components that exist between the terminals to which the component under test is connected, that is, it will include both the constants of the com-

ponent itself and those due to the leads connecting the component to the test circuit.

To explain this more fully, consider the parallel combination of a capacitor C_P , with self-inductance L_P , and shunt conductance G_P . In series with this combination is the inductance L_S , and conductance G_S , of the leads protruding from the body of the capacitor. This overall series/parallel combination can be said to be equal to a single capacitance C and conductance G in parallel.

The evaluation of C_P and G_P is generally of academic interest only, because any circuit into which such a capacitor might be connected will be presented with an impedance which includes the constants of the capacitor together with the constants of the leads connecting the capacitor into the circuit. In other words, the circuit will 'see' a parallel G - C combination and not a G_P - C_P combination.

The procedure detailed in Section 5 enables the effective values (G - C) to be calculated except where otherwise stated.

It is usual to connect the component under test with the shortest possible leads. If it is desired to simulate a particular operational condition, the connecting leads should be approximately equal in length and configuration to those anticipated when the component is connected into the particular circuit.

On occasions, the operator may be forced to use leads in addition to those associated directly with the component under test. In such circumstances, the extra leads should be as thick as possible or, preferably, should be tape or braid so that the error due to these additional leads may be considered negligible compared with the leads directly associated with the component under test.

When measurements are made by the series method and it is desired to eliminate lead inductance, the method of connection described below can be employed. This applies particularly in cases where the component is too large, physically, to enable connection to be made with virtually zero lead length. The Series Loss Test Jig is not quite suitable for such measurements because unless the component is so dimensioned that it just bridges the gap between the terminals of the Jig, its leads form an unknown variable that is not measured either directly or indirectly.

It is necessary to provide (a) a pair of stable connectors to link the component to the Jig and (b) a 'shorting' strip of known (calculated) inductance having a length equal to the distance between the connections to the component.

The stable connectors can be fabricated from a pair of crocodile clips and a length of fairly stiff

capacitor, the terminal groups and the valve voltmeter diode are all mounted on a substantial aluminium-alloy cast frame for good stability. This tuning unit is shown in Fig. 6.2. The tuning capacitor is, in fact, two ganged sections, the rotors being on a common spindle with the two stators mounted on a low-loss ceramic plate. The smaller section of 7.5 to 110 $\mu\mu\text{F}$, is used in the h.f. test circuit, and when the HI I and HI II terminals are linked the other larger section is connected in parallel with it to give a total capacitance range for the l.f. test circuit of 20 to 500 $\mu\mu\text{F}$.

The capacitor spindle drive mechanism consists of a main tuning control of near-direct drive ratio and a fine incremental control with a drive reduction of approximately 50 : 1. A face cam on the incremental-tuning control spindle actuates a lever which rotates the capacitor spindle via a spring-loaded clutch. When operating the incremental control the clutch is solid and the main drive rotates, maintaining absolute capacitance calibration; but when turning the main control the clutch is overdriven and the incremental control is inoperative.

6.3 VOLTAGE INJECTION SYSTEMS

A separate injection system is used in each test circuit, the l.f. injection is resistive and the h.f. inductive. In both systems the injection voltage is 20 mV, derived from 25:1 potentiometers; the voltage input to each system being 0.5 volt. The l.f. injection potentiometer (R27, R26) comprises a

non-inductive disk resistor of 0.5 ohm with a concentric tapping to give an injection resistance of 20 m Ω . Above about 50 Mc/s even 20 m Ω becomes a significant circuit loss so inductive injection is used for the h.f. test circuit. Here also a 25:1 potentiometer (L2, L1) is used, consisting of a flat screened inductor 2.5 in. long, tapped 0.1 in. from its earthed end. This gives an injection inductance of approximately 0.1 m μH .

The two potentiometers are accurately adjusted during manufacture so that by monitoring the more manageable input level of 0.5 volt the actual injection voltage can be easily determined. This high voltage level enables crystal voltmeter circuits to be used as injection monitors; two full-wave circuits are used here, both feeding the same moving coil meter, M2, which is calibrated in Q-multiplying factors. Full-wave circuits are used so that errors due to any distortion in the input signals are minimized, for since the Q-reading valve voltmeter measures a virtually perfect sine-wave so should the input monitors.

6.4 VALVE VOLTMETER

A disk-seal u.h.f. diode, V4, is used to rectify the voltage developed across the test circuit capacitor. The output from the diode is then applied to a double-triode d.c. bridge circuit with a moving-coil meter, M1, as the indicator.

The diode is used as a series rectifier and is mounted directly behind the 7.5 to 110 $\mu\mu\text{F}$ tuning capacitor. The use of a series circuit ensures the lowest shunt loss possible, since the loss presented

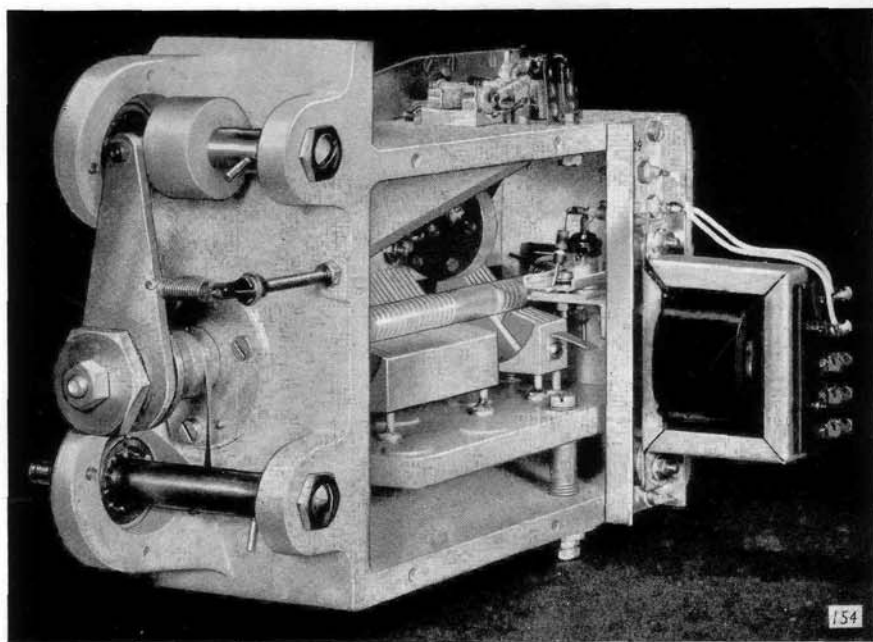
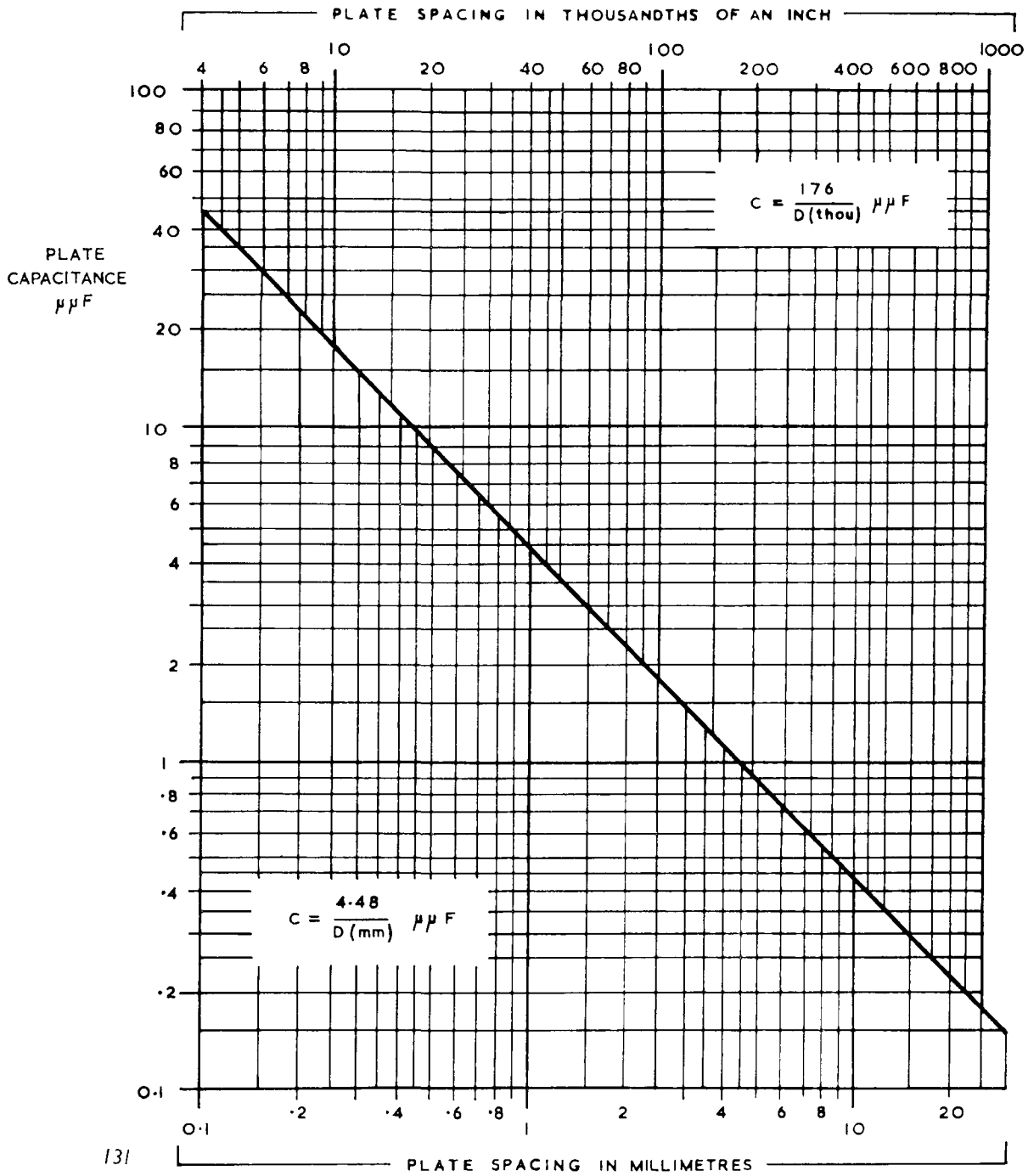

Fig. 6.2 Resonating Capacitor Unit.



Note: Calibration Figure for Linear Capacitor is included with Jig.

Fig. 5.7 Capacitance of plate Capacitor due to Uniform Field.

5.5 MEASUREMENTS ON INSULATING MATERIALS

For the measurement of the permittivity and dielectric constant of solid dielectric insulating materials, the Dielectric Loss Test Jig TJ 155B 1 or TJ 155C 1 should be used. The two jigs are identical except that the 'B 1' is calibrated in thousandths of an inch and the 'C 1' in millimetres.

The jig plugs into the 1f test circuit HI and E terminals (see Fig 5 6), and is retained there by a special screw supplied with the jig.

The screw passes through the hole in the jig insulator between the two micrometer heads and locates in a threaded bush in the front panel of the Q-Meter.

When finally assembled, the micrometer heads should be at the top. The left-hand micrometer

capacitor is a linear-law capacitor and is used for bandwidth determinations. The right-hand capacitor is a plate capacitor to hold the specimen under test.

5.5.1 PREPARING THE SPECIMEN

The specimen should preferably be between about 25.4 and 27 mm (1 and 1.06 in) in diameter so that it projects slightly around the edge of the electrodes, this gives a good compromise between errors due to surface leakage over the edge of the specimen and errors due to the fringing of the electric field. The exact thickness of the specimen is not important, but should be of the order of 1 to 5 mm as it becomes difficult to obtain accurate results with specimens much outside these limits.

The surface of the specimen should be as flat as possible, for the best possible accuracy, disks of thin tin-foil about 0.002 in (0.05 mm) thick and

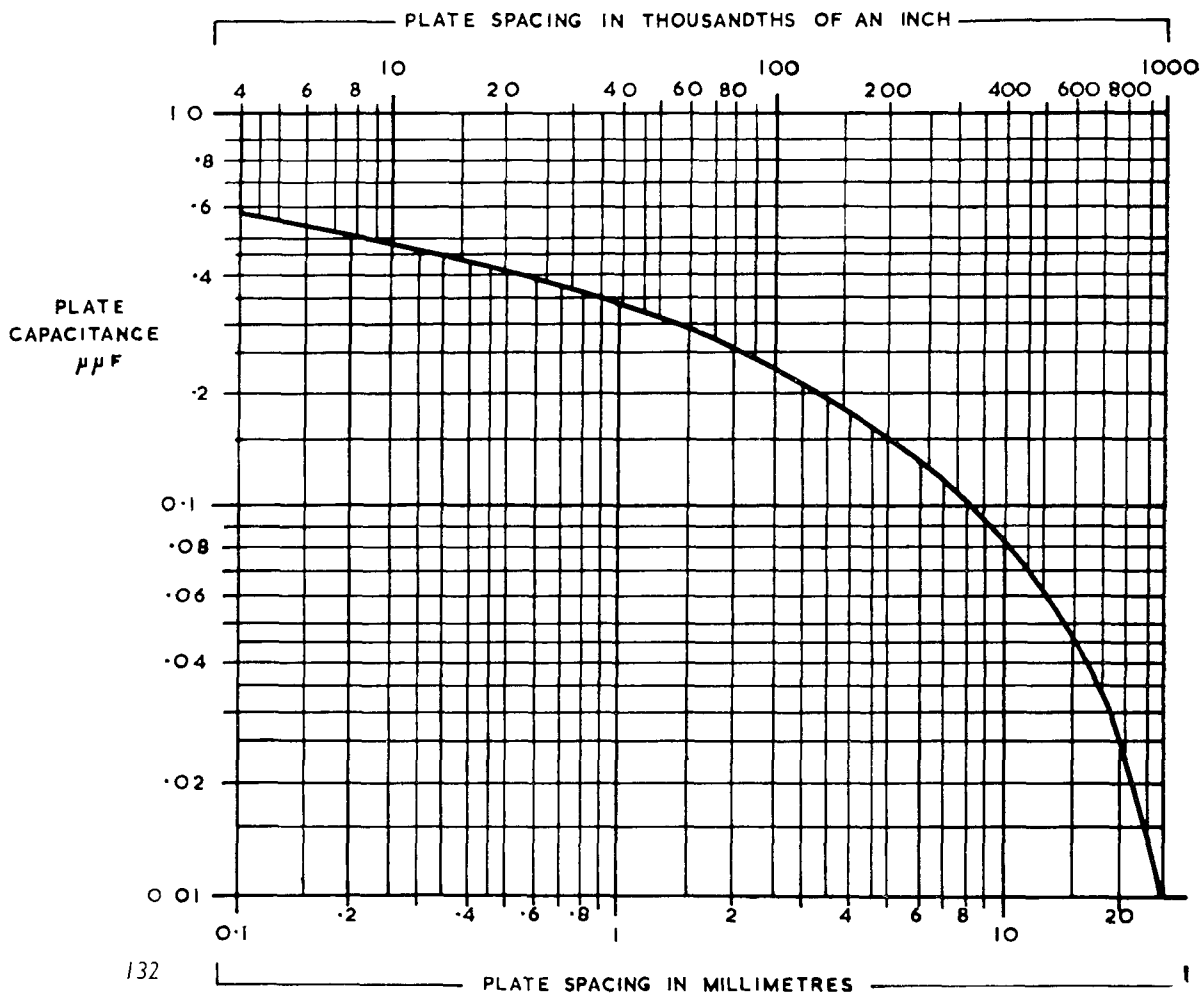

Fig 5 8 Capacitance of plate Capacitor due to Fringe Field

1 in (25.4 mm) diameter must be carefully applied to the surfaces of the specimen with a trace of vaseline. The main-capacitor electrodes are then made to cover the foil when the specimen is in position. The smallest possible trace of vaseline should be used and the foil smoothed into place with a small pad so that all air is excluded. When properly applied, the foil should have the appearance of a mirror.

5.5.2 MAKING A MEASUREMENT

The procedure described below is the fundamental and preferred method of measurement. However, it is sometimes more convenient to treat the specimen as the dielectric of a capacitor formed by the jig and measurements made as described in Section 5.2.1.

- (1) Set the main tuning capacitor control on the Q-Meter to around minimum capacitance.
- (2) Connect the jig to the I f test circuit terminals.
- (3) Connect a suitable resonating inductor to the HI and LO terminals.
- (4) Insert the specimen between the electrodes of the plate capacitor. Screw down the micrometer until the specimen is just held. Use the small ratchet-controlled knob at the end of the micrometer head to avoid overtightening the micrometer. Let the plate-micrometer reading *minus* the total thickness of the foil, if used, be D_1 .
- (5) Set the linear capacitor to 12.5 mm or 0.5 in., as appropriate.
- (6) Resonate the test circuit by means of the oscillator frequency control. In order to obtain a convenient reading on the Q AND δQ meter, adjust the oscillator amplitude control.
- (7) Detune the linear capacitor and note its micrometer reading both above and below resonance, when the indicated Q reading is halved. Let the total change in micrometer reading be M_1 .
- (8) Adjust the linear capacitor to restore resonance. Do not alter the oscillator frequency.
- (9) Remove the specimen and, without altering the oscillator frequency, resonate the test circuit by means of the plate capacitor. Let the new plate capacitor setting be D_2 .
- (10) Detune the linear capacitor and note its micrometer readings, both above and below

resonance, when the indicated Q reading is halved. Let the total change in micrometer reading be M_2 .

5.5.3 CALCULATING THE RESULT

The permittivity of the specimen is given by

$$k = \frac{D_1}{D_2} \quad (56)$$

In general, this expression will give a result accurate to within $\pm 5\%$. If the plate capacitor change, from specimen-in to specimen-out, is large so that the change in fringe capacitance is appreciable, the following expression should be used

$$k = \frac{C_2 - C_{F_2} - C_{F_1}}{C_1} \quad (57)$$

where C_1 = the capacitance of an air-dielectric capacitor having spacing = D_1 (See curve, Fig. 5.7.)

C_2 = the capacitance of an air-dielectric capacitor having spacing D_2 (See curve, Fig. 5.7.)

C_{F_1} = the effective fringe capacitance when the plate capacitor is set to spacing D_1 (See curve Fig. 5.8.)

C_{F_2} = the effective fringe capacitance when the plate capacitor is set to spacing D_2 (See curve, Fig. 5.8.)

The loss tangent of the specimen is given by

$$\tan \delta x = \frac{P(M_1 - M_2)}{15.5} \quad D_2 \text{ where } D_2 \text{ is in millimetres} \quad (58)$$

$$\tan \delta x = \frac{P(M_1 - M_2)}{610} \quad D_2 \text{ where } D_2 \text{ is in thousandths of an inch} \quad (59)$$

where P = the conversion factor for the linear capacitor and is marked inside the lid of the box in which the jig is supplied.

If the plate capacitor change, from specimen-in to specimen-out, is large so that the change of fringe capacitance is appreciable, the following expression should be used

$$\tan \delta x = \frac{P(M_1 - M_2)}{3.46 (C_2 + C_{F_2} - C_{F_1})} \quad (60)$$

The quantities C_2 , C_{F_1} , and C_{F_2} are determined as in expression (57).

6 TECHNICAL DESCRIPTION

The following detailed description is intended to be read in conjunction with the circuit diagram, Fig. 10.6.

6.1 GENERAL

The Circuit Magnification Meter TF 1245 incorporates two separate low-loss test circuits to ensure optimum operating conditions over the complete range of 1 kc/s to 300 Mc/s. Both are of the conventional series-resonant type, in which Q is measured in terms of the voltage developed across the tuned-circuit capacitor.

Separate voltage injection systems are used for each test circuit; a crystal voltmeter monitors the level of the input signal and indicates the Q multi-

plication factor. The circuit Q is measured by a valve voltmeter connected across the h.f. test circuit tuning capacitor, this being common to both test circuits; the value of Q is read from a panel-mounted meter.

6.2 MECHANICAL LAYOUT

For ease of operation all controls, terminals and meters are mounted on the sloping front panel. The terminals for the two test circuits are arranged in two adjacent groups; those for the l.f. test circuit have socket holes to accept the standard plug-in inductors, of either Marconi or US pattern, and the two Loss Test Jigs.

The voltage injection systems, the tuning

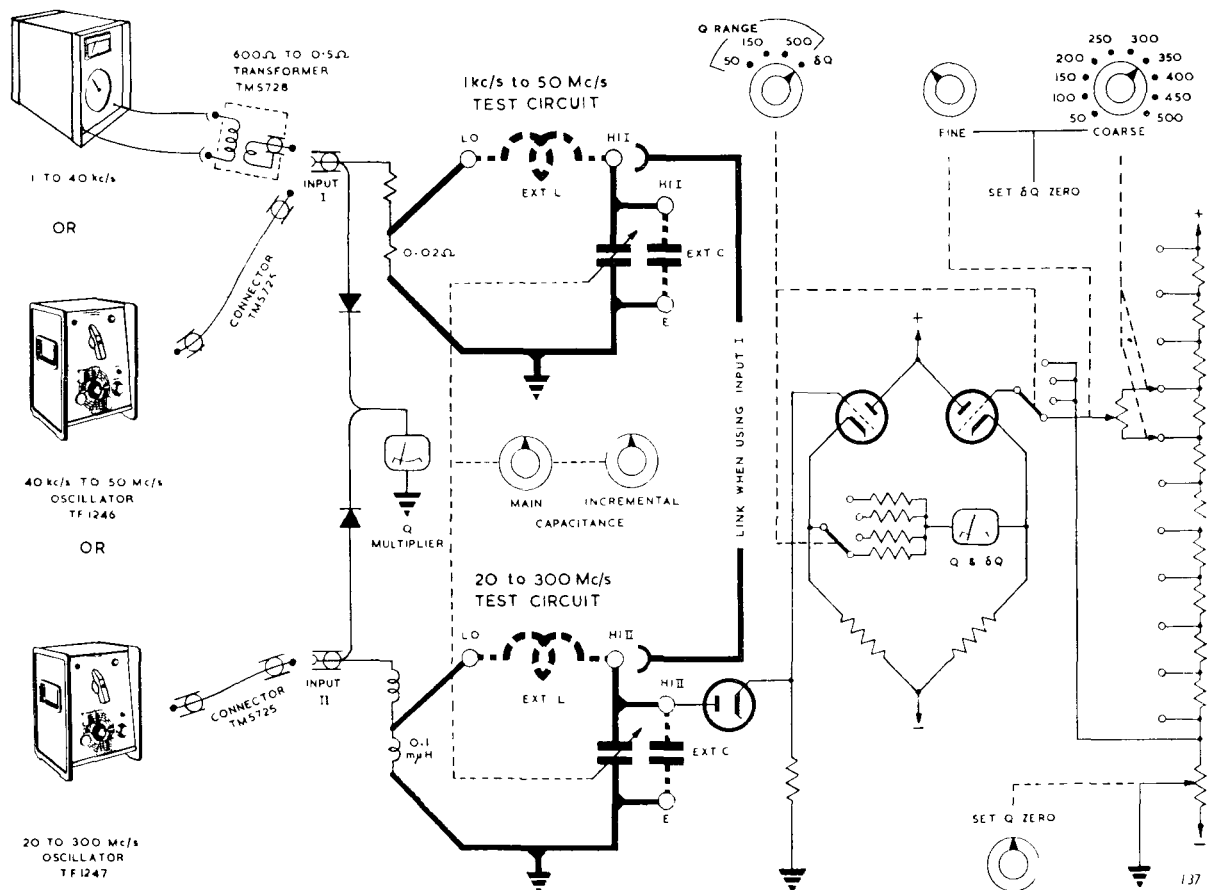

Fig. 6.1 Functional Diagram.

$$\frac{\lambda}{8} = \frac{\lambda_0}{8\sqrt{k}} \dots\dots\dots(47)$$

where λ = the wavelength in the transmission line.
 λ_0 = the free-space wavelength.
 k = the dielectric constant of the transmission line medium.

When the dielectric constant is not known, the physical length of the line should be made no greater than $\lambda_0/16$.

5.4.2 EFFECTIVE SHUNT CAPACITANCE AND CONDUCTANCE

This measurement is made on the open-circuit line. The measurement procedure is exactly the same as that described in Section 5.2.1 for small-value capacitors.

From expression (27), the effective shunt capacitance of the line for the length of line under test is given by

$$C_d = C_1 - C_2 \dots\dots\dots(48)$$

From expression (29), the effective shunt conductance of the line for the length of line under test is given by

$$G_d = \frac{Q_1 - Q_2}{Q_1 Q_2} \cdot \omega C_1 \dots\dots\dots(49)$$

Note: The correction for effective capacitance mentioned in Section 5.2.1 may be applied in expressions (48) and (49).

5.4.3 EFFECTIVE SERIES INDUCTANCE AND RESISTANCE

This measurement is made on the short-circuit line. The measurement procedure is exactly the same as that described in Section 5.1.7 for small-value inductors.

From expression (23), the effective series inductance of the line for the length of line under test is given by

$$L_s = \frac{C_1 - C_2}{\omega^2 C_1 C_2} \dots\dots\dots(50)$$

From expression (25), the effective series resistance of the line for the length of line under test is given by

$$R_s = \frac{1}{\omega} \left\{ \frac{1}{C_2 Q_2} - \frac{1}{C_1 Q_1} \right\} \dots\dots\dots(51)$$

5.4.4 CALCULATION OF TRANSMISSION LINE CONSTANTS

In the following expressions, the quantity S is the physical length of the line in metres.

OM 1245
2-4/68

The characteristic impedance of the line is given by

$$Z_0 = \sqrt{\frac{R_s + j\omega L_s}{G_d + j\omega C_d}} \approx \sqrt{\frac{L_s}{C_d}} \dots\dots(52)$$

The attenuation of the line is given by

$$A = \frac{1}{2S} \cdot \frac{G_d Z_0 + \frac{R_s}{Z_0}}{1 + \omega^2 L_s C_d} \text{ nepers/metre} \dots\dots(53)$$

$$\approx \frac{1}{2S} \left\{ G_d Z_0 + \frac{R_s}{Z_0} \right\} \text{ nepers/metre}$$

when $S < \lambda/60$

$$= \frac{4.34}{S} \left\{ G_d Z_0 + \frac{R_s}{Z_0} \right\} \text{ dB/metre}$$

The phase velocity of the line is given by

$$v = \frac{\omega S}{\tan^{-1} \omega \sqrt{L_s C_d}} \text{ metres/second} \dots\dots(54)$$

$$\approx \frac{S}{\sqrt{L_s C_d}} \text{ metres/second when } S < \lambda/30.$$

The dielectric constant of the line is given by

$$k = \left\{ \frac{3 \times 10^8 L_s}{Z_0 S} \right\}^2 \dots\dots\dots(55)$$

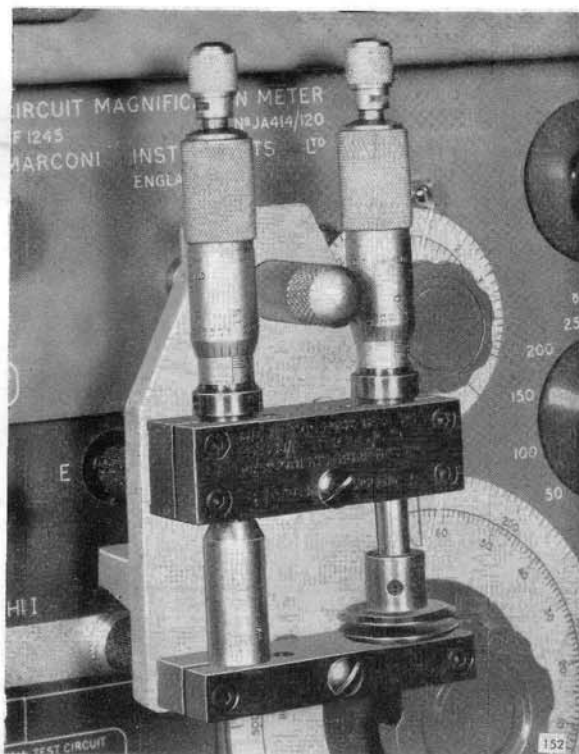

Fig. 5.6 Test Jig, Type TJ 155B/1, fitted for Dielectric Loss Measurements.

- to be as high as possible, the correction can be significant particularly for high-Q components resonated with low-value capacitances (See Section 4 3 2)
- (3) *Residual Inductance* This correction need only be considered if (i) the residual inductance will have a marked effect on the effective value of resonating capacitance and/or (ii) it is comparable with the inductance of the circuit inductor (See Section 4 3 3)
- (4) *Injection Impedance* This correction need only be considered if the circuit inductance or inductor h f resistance, depending on the type of injection, is comparable with the injection impedance (See Section 4 3 4)

- (5) *Voltmeter Frequency Response and Transit Time Error* Can be ignored under all conditions (See Section 4 3 5)
- (6) *Connecting Lead Inductance* It is normally only necessary to take this factor into account in certain series measurements. (See Section 4 3 6)

4.4 DISTRIBUTION OF RESIDUAL COMPONENTS

For values of $Q_C (= \omega C_{ind} R_P)$ see Fig 10 4 at the end of this handbook

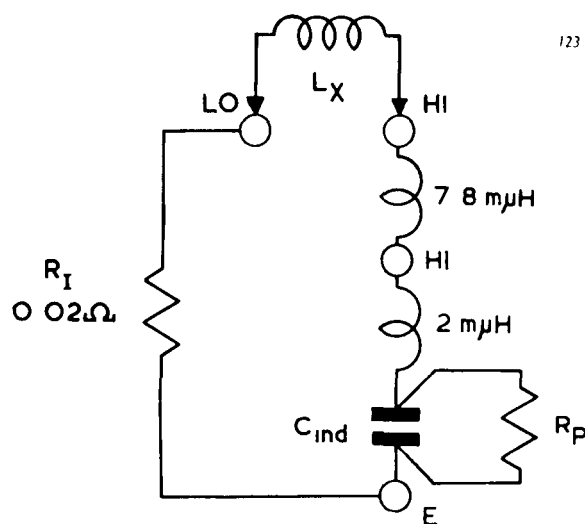

Fig 4 9 L F Test Circuit

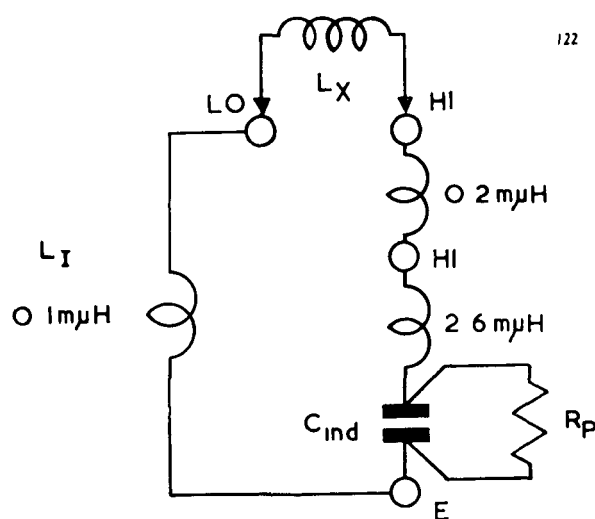

Fig 4 10 H F Test Circuit

5 MEASUREMENTS WITH CORRECTIONS

This section describes the procedure for making a wide range of direct and indirect measurements with the Q-Meter and its accessories, and includes the application of the corrections that may be necessary for the highest accuracy of result. It is assumed that the user is already familiar with the general operating techniques and basic Q-measuring procedure detailed in Section 2.

5.1 MEASUREMENTS ON INDUCTORS

5.1.1 Q—DIRECT METHOD

- (1) Connect the inductor under test to the HI and LO terminals
- (2) Resonate the test circuit by adjustment of either the tuning capacitor or the oscillator frequency as convenient. Let the indicated resonating capacitance at resonance be C_{ind}
- (3) Note the indicated Q reading on the Q AND δQ meter

For most measurements, this Q reading (Q_{ind}) can be taken as being the true Q of the inductor (Q_T). Under certain circumstances, however, it may be advisable to apply corrections in order to obtain the true Q of the inductor. The most significant correction is that for the self-capacitance (C_0) of the inductor under test which can be evaluated as described in Section 5.1.4 or 5.1.5. Applying this correction,

$$Q_T = Q_{ind} \left\{ 1 + \frac{C_0}{C_{ind}^*} \right\} \quad (12)$$

It must be remembered that Q_T is strictly the true Q of the complete circuit and not that of the inductor under test. Q_T can, for almost all practical purposes, be said to be the Q of the inductor, provided (i) the capacitor Q is high compared with Q_T and (ii) the residual impedance of the circuit is negligible compared with the effective series impedance of the inductor under test. For details of these other corrections, refer to Section 5.1.3.

* In general, it is sufficient to use the indicated value of capacitance in the expression. Strictly, the effective value (C_E) should be used. Graphs of effective against indicated values are given in Figs. 10.2 and 10.3 at the end of this handbook.

5.1.2 Q—INCREMENTAL-CAPACITANCE METHOD

- (1) Connect the inductor under test to the HI and LO terminals
- (2) Set the incremental-capacitance dial to its central, zero position
- (3) Resonate the test circuit by adjustment of either the tuning capacitor or the oscillator frequency as convenient
- (4) Note the reading on the Q AND δQ meter. Let this reading be Q_R
- (5) By means of the incremental-capacitance control, detune on both sides of the resonance point until the Q AND δQ meter reads at 0.707 Q_R . Let this reading be Q_D
- (6) Note the incremental-capacitance dial reading in each case

Let the total capacitance change be δC_{ind} and the tuning-capacitor setting at resonance be C_{ind} . The Q of the complete circuit is then given by

$$Q_{ind} = \frac{2C_{ind}}{\delta C_{ind}} \quad (13)$$

The general expression for Q_{ind} is

$$Q_{ind} = \frac{2C_{ind}}{\delta C_{ind}} \sqrt{\left\{ \frac{Q_R}{Q_D} \right\}^2 - 1} \quad (14)$$

In the particular case where $Q_D = 0.707 Q_R$, expression (14) simplifies to expression (13).

The principal error, particularly when Q is large, will be the observational error, consequently, it is good practice to make a number of measurements, at different values of Q_R , Q_D , and take the average.

For most measurements, this Q value (Q_{ind}) can be taken as being the true Q of the inductor (Q_T). Under certain circumstances, however, it may be necessary to apply corrections in order to obtain the true Q of the inductor. The most significant correction is that for the self-capacitance (C_0) of the inductor under test which can be evaluated as described in Section 5.1.4 or 5.1.5. Applying this correction to expression 13,

$$Q_T = \frac{2(C_{ind} + C_0)}{\delta C_{ind}} \quad (15)$$

It must be remembered that Q_T is strictly the true Q of the complete circuit and not that of the inductor under test. Q_T can, for almost all practical

purposes, be said to be the Q of the inductor, provided (i) the capacitor Q is high compared with Q_T and (ii) the residual impedance of the circuit is negligible compared with the effective series impedance of the inductor under test. For details of these other corrections, refer to Section 5.1.3.

5.1.3 ADDITIONAL CORRECTIONS FOR Q MEASUREMENT

The preceding sections, 5.1.1 and 5.1.2, give details of the correction for C_0 . There are a number of other corrections which it may be advisable to apply under certain circumstances in order to obtain the absolute Q of the inductor independent from any particular test circuit.

Assuming the correction for C_0 has already been applied, the absolute Q of the inductor under test is given by

$$Q_A = \frac{X_{CT}}{R_X} \quad (16)$$

where X_{CT} = the total capacitive reactance of the test circuit at resonance and is calculated from the expression

$$X_{CT} = \frac{1}{\omega(C_E + C_0)}$$

C_E = the effective value of resonating capacitance (graphs of C_E against C_{ind} are given in Figs 10.2 and 10.3 at the end of this handbook)

C_0 = the self-capacitance of the inductor under test

R_X = the effective series resistance of the inductor under test and is calculated from the expression

$$R_X = \frac{X_{CT}}{Q_T} - \frac{Q_C}{\omega C_{ind}(1 + Q_C^2)} - R_R$$

Q_C = the magnification of the circuit capacitor at capacitance C_{ind} (a graph of Q_C against C_{ind} is given in Fig 10.4 at the end of this handbook)

C_{ind} = the capacitance reading of the tuning capacitor dial at resonance

R_R = the residual resistance of the test circuit (0.02 Ω , for the 1f test circuit, negligible, for the hf circuit)

5.1.4 L, C_0 AND R—NATURAL FREQUENCY METHOD

The inductance, self-capacitance, and resistance of an inductor can be determined by making measurements at two frequencies, one of which is arranged to be the natural resonant frequency of the inductor.

- (1) Connect the inductor under test to the HI and LO terminals
- (2) Set the tuning capacitor to maximum capacitance
- (3) Adjust the oscillator frequency to obtain resonance

Let the frequency and the indicated tuning capacitance at resonance be f_1 and C_1 respectively. With the usual values of self-capacitance possessed by practical inductors, it is a good, but not rigid, guide to expect the natural frequency to be 5 to 10 times f_1 , therefore check that the probable natural frequency is within the range of the oscillator.

- (4) Remove the inductor under test, and in its place, connect an inductor that will resonate at the probable natural frequency
- (5) Set the oscillator to about $7\frac{1}{2}$ times f_1
- (6) By means of the tuning capacitor, resonate the test circuit
- (7) Connect the inductor under test in parallel with the resonating inductor and restore resonance by means of the tuning capacitor

If, in order to restore resonance, the tuning capacitor setting has to be increased, increase the oscillator frequency. If the tuning capacitor setting has to be reduced, decrease the oscillator frequency.

- (8) Remove the inductor under test and resonate the test circuit at the new frequency
- (9) Repeat operations (7) and (8) until the addition of the inductor under test causes no change in the resonating capacitance required to maintain resonance

Let the indicated Q, as read on the Q AND δQ meter, with the inductor under test disconnected be Q_1 . Let the indicated Q with the inductor under test connected be Q_2 . Let the indicated tuning capacitance at the natural frequency be C_2 .

The test circuit is now tuned to the natural frequency (f_0) of the inductor under test. The self-capacitance of the inductor under test is then given by

$$C_0 = \frac{C_1^*}{\left\{\frac{f_1}{f}\right\}^2 - 1} \simeq \left\{\frac{f_1}{f_0}\right\}^2 C_1^* \quad (17)$$

* In general, it is sufficient to use the value C_{ind} in this expression. Strictly, the effective value of tuning capacitance (C_E) should be used. Graphs of C_E against C_{ind} are given in Figs 10.2 and 10.3 at the end of this handbook.

and the absolute inductance of the inductor under test is given by

$$L_x = \frac{1}{\omega_0^2 C_0} \dots \dots \dots (18)$$

The effective shunt resistance of the inductor at its natural frequency (f_0) is given by

$$R_{XP} = \frac{Q_1 Q_2}{Q_1 - Q_2} \cdot \frac{1}{\omega_0 C_1^*} \cdot \left\{ 1 + \frac{C_0}{C_1^*} \right\} \dots (19)$$

5.1.5 C₀—FREQUENCY DOUBLING METHOD

A quick and simple method of determining the self-capacitance of an inductor is to make two measurements, one at twice the frequency of the other.

- (1) Connect the inductor under test to the HI and LO terminals
- (2) Set the tuning capacitor to maximum capacitance.
- (3) Adjust the oscillator frequency to obtain resonance.

- Let the frequency and indicated tuning capacitance at resonance be f_1 and C_1 respectively.
- (4) Set the oscillator frequency to 2 times f_1 .
- (5) Restore resonance by means of the tuning capacitor.

Let the indicated tuning capacitance at frequency $2f_1$ be C_2 . The self-capacitance of the inductor under test is then given by

$$C_0 = \frac{C_1^* - 4C_2^*}{3} \dots \dots \dots (20)$$

5.1.6 L—DIRECT METHOD

Inductance values between 40 mμH and 100 mH can be measured by direct connection to the test-circuit terminals. The inductance is measured in terms of the tuning capacitance required to resonate the inductor at a particular frequency and then translated to inductance by reference to the chart on the top of the instrument. The chart is reproduced in Fig. 5.1

- (1) Connect the inductor under test to the HI and LO terminals.
- (2) Estimate the probable inductance and, by reference to the chart, select the oscillator frequency which embraces the expected inductance value. The test frequencies are denoted by dots on the oscillator dials.
- (3) Resonate the circuit by means of the tuning capacitor and note the dial reading. Let this value be C_{ind} .
- (4) Convert this dial reading to inductance by reference to either scale 'A' or scale 'B,' as appropriate, on the chart.

Alternatively, the inductance value can be determined at any frequency by the use of the expression

$$L_{ind} = \frac{1}{\omega^2 C_{ind}} \dots \dots \dots (21)$$

For most measurements, this value of inductance (L_{ind}) can be taken as being the true inductance (L_x) of the inductor under test. Under certain circumstances, however, it may be necessary to apply corrections in order to obtain the true inductance. The most significant correction is that

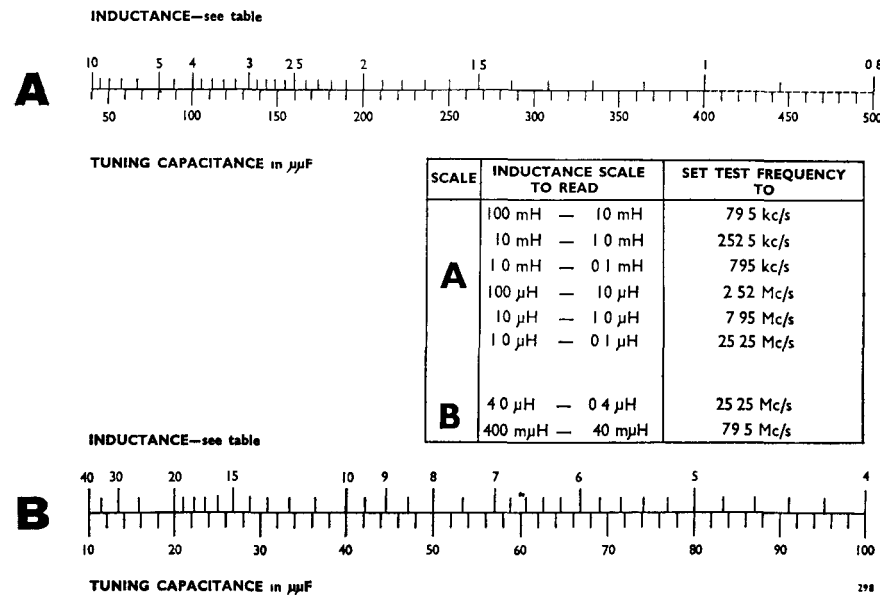

Fig. 5.1
Capacitance-Inductance
Conversion Chart.

for the self-capacitance (C_0) of the inductor under test. Applying this correction,

$$L_X = L_{ind} \left\{ \frac{C_{ind}}{C_{ind} + C_0} \right\} \quad (22)$$

For the smallest inductances, less than about 100 $m\mu H$, subtract L_R , the residual inductance of the circuit, from $L_X - L_R$ for the l f test circuit is 9.8 $m\mu H$, and 2.8 $m\mu H$ for the h f. circuit

5.1.7 L AND R—SERIES METHOD

An alternative method of measuring inductance—particularly on low-value inductors—is to connect them in series with the test circuit. The most convenient way of accomplishing this is by means of the Series Loss Test Jig TJ 230 (for details, see Section 1.2).

The range of inductors that can normally be measured by this means is shown in Fig 5.2. It should be remembered that maximum accuracy is obtained when the capacitance change is 2:1

- (1) Connect the Series Loss Test Jig TJ 230 to the l f test-circuit terminals (see Section 2.4.5)
- (2) Connect the inductor under test to the jig.
- (3) Connect a reference inductor, of the TM 1438 series, to the jig

Optimum accuracy is obtained when the value of the reference inductor is approximately equal to that of the inductor under test

** In general, it is sufficient to use the value C_{ind} in this expression. Strictly, the effective value of tuning capacitance (C_E) should be used. Graphs of C_E against C_{ind} are given in Figs 10.2 and 10.3 at the end of this handbook*

- (4) Short-circuit the inductor under test by means of the screw switch
- (5) Set the tuning capacitor dial to about the middle of its range. Let this indicated capacitance be C_1
- (6) Resonate the test circuit by adjustment of the oscillator frequency
Note the reading on the Q AND δQ meter; let this reading be Q_1 .
- (7) Bring the inductor under test into circuit by unscrewing the screw switch
- (8) Resonate the test circuit by means of the tuning capacitor. Let the indicated tuning capacitance at resonance be C_2

Note the reading on the Q AND δQ meter; let this reading be Q_2

The inductance of the inductor under test is then given by

$$L_X^* = \frac{C_1 - C_2}{\omega^2 C_1 C_2} \dots \dots \dots (23)$$

If L_X is negative, the measurement has been made at a frequency above the natural frequency of the inductor. The effective series capacitance of the inductor under test is then given by

$$C_X = \frac{1}{\omega^2 L_X^*} \dots \dots \dots (24)$$

The effective series resistance of the inductor under test is then given by

$$R_X = \frac{1}{\omega} \left\{ \frac{1}{C_2 Q_2} - \frac{1}{C_1 Q_1} \right\} \quad (25)$$

** Strictly, expression (23) should include correction for the self-capacitance of both inductors. In general, ignoring this correction will introduce errors of less than 10%*

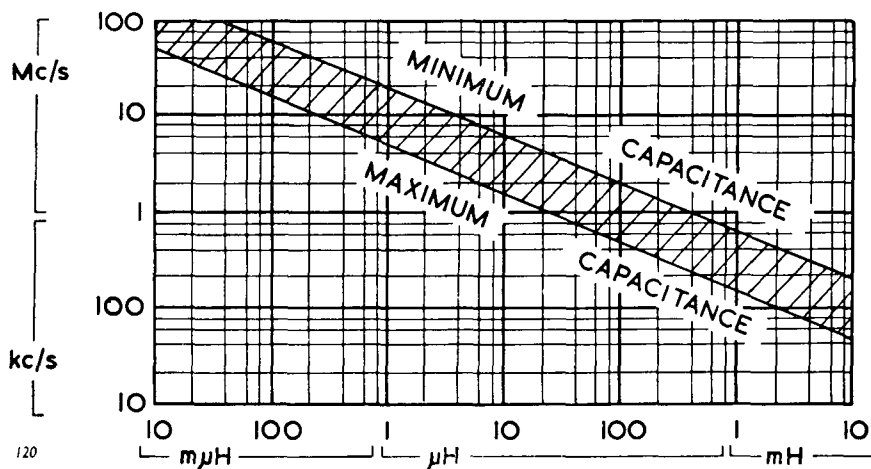

Fig. 5.2 Inductance Measurement Range—Series Method

Applying this correction,

$$L_x = \frac{(C_1 + C_o) - (C_2 + C_o')}{\omega^2(C_1 + C_o)(C_1 + C_o')}$$

where C_o = the self-capacitance of the resonating inductor

C_o' = the self-capacitance of the combined resonating and test inductors.

5.1.8 R—GENERAL METHOD

The general method of determining the effective series resistance of an inductor under test is to calculate the value from a knowledge of the inductance and Q of the component. The effective series resistance is given by

$$R_x = \frac{\omega L}{Q} \dots\dots\dots(26)$$

Corrections for L and Q should be applied where appropriate.

5.2 MEASUREMENTS ON CAPACITORS

5.2.1 C, TAN δ , AND R—SMALL-VALUE CAPACITORS

For measurements on capacitors of less than 480 $\mu\mu F$, using the l.f. test circuit, or 100 $\mu\mu F$, using the h.f. test circuit, the following direct-substitution method can be used. The measurement may be carried out at any frequency but it must be remembered that the effective capacitance varies with frequency because of the residual self-inductance of the capacitor under test.

- (1) Connect a suitable resonating inductor to the HI and LO terminals.
- (2) Set the tuning-capacitor dial to around maximum capacitance. Let this capacitance be C_1 . If the capacitance value of the unknown is small, C_1 should be set to near minimum capacitance to allow greater discrimination.
- (3) Resonate the test circuit by adjustment of the oscillator frequency. Let the indicated Q reading at resonance be Q_1 .
- (4) Connect the capacitor under test to the HI and E terminals.
- (5) Resonate the test circuit by adjustment of the tuning capacitor. Let the new tuning-capacitor setting at resonance be C_2 and the indicated Q reading be Q_2 .

The effective capacitance of the capacitor under test is given by

$$C_{XP} = C_1^* - C_2^* \dots\dots\dots(27)$$

If it is now required to measure the absolute capacitance, refer to Section 5.2.3.

The phase defect is given by

$$\text{Tan } \delta_x = \frac{Q_1 - Q_2}{Q_1 Q_2} \cdot \frac{C_1^*}{C_1^* - C_2^*} \dots\dots\dots(28)$$

The effective shunt resistance is given by

$$R_{XP} = \frac{Q_1 Q_2}{Q_1 - Q_2} \cdot \frac{1}{\omega(C_1^*)} \dots\dots\dots(29)$$

5.2.2 C, TAN δ , AND R—LARGE-VALUE CAPACITORS

For measurements on capacitors of between 480 $\mu\mu F$ and about 0.25 μF , using the l.f. test circuit, the following method can be used. In this method, the capacitor under test is connected in series with the test circuit by means of the Series Loss Test Jig TJ 230 (for details, see Section 1.2).

In order to retain the d.c. path between the Q AND δQ meter input diode and earth it is necessary to connect a high-value resistor across the capacitor under test. The resistor should be about 1M Ω nominal value, of small physical size.

- (1) Connect the Series Loss Test Jig TJ 230 to the test-circuit terminals (see Section 2.4.5).
- (2) Connect the capacitor under test together with the shunt resistor to the screw terminals of the jig.
- (3) Connect a suitable resonating inductor to the jig.
- (4) Short-circuit the capacitor under test by means of the screw switch.
- (5) Set the tuning-capacitor dial to about the middle of its range. Let this capacitance be C_1 .
- (6) Resonate the test circuit by adjustment of the oscillator frequency. Let the indicated Q reading be Q_1 .
- (7) Bring the capacitor under test into circuit by unscrewing the screw switch.

* In general, it is sufficient to use the indicated value of the tuning capacitance. Strictly, the effective value should be used. Graphs of effective value against indicated value of tuning capacitance are given in Figs. 10.2 and 10.3 at the end of this handbook.

- (8) Resonate the test circuit by adjustment of the tuning capacitor. Let the tuning capacitance at resonance be C_2 and the indicated Q reading be Q_2 .

Optimum measurement accuracy is obtained by using a high-Q inductor and the δQ facility.

At the test frequency the effective value of the shunt resistor will probably be less than its d.c. value. Its effective value at this frequency must therefore be determined by the method described in Section 5.3.2. Let this value be denoted by R_{SH} .

The effective series capacitance of the capacitor under test is given by

$$C_X = \frac{C_1 C_2}{C_2 - C_1} \dots \dots \dots (30)$$

The value of C_X obtained includes the inherent capacitance of the shunt resistor, which should, however, be negligibly small, but if considered necessary it may be evaluated from expression 41 in Section 5.3.2.

If C_X is negative, the measurement has been made at a frequency greater than the natural frequency of the capacitor. The effective inductance of the capacitor is then given by

$$L_X = \frac{1}{\omega^2 C_X} \dots \dots \dots (31)$$

If it is now required to measure the absolute capacitance, refer to Section 5.2.3.

The Q of the capacitor and shunt resistor combination is given by

$$Q = \frac{Q_1 Q_2 (C_2 - C_1)}{C_1 Q_1 - C_2 Q_2}$$

The shunt resistance of the capacitor under test is given by

$$R_{XP} = \frac{Q R_{SH}}{\omega C_X R_{SH} - Q} \dots \dots \dots (32)$$

Therefore, for capacitors of $Q > 10$, the phase defect may be determined from

$$\tan \delta_X = \frac{1}{\omega C_X R_{XP}} \dots \dots \dots (33)$$

5.2.3 ABSOLUTE CAPACITANCE AND SELF-INDUCTANCE—GENERAL

The preceding sections, 5.2.1 and 5.2.2, give details for measuring the *effective* capacitance, at the frequency of test, of the capacitor under test. The effective capacitance is made up of three components: the absolute capacitance and the self-inductance of the capacitor together with the inductance of any leads used to connect the

capacitor to the test circuit. The effective capacitance is given by

$$\frac{1}{\omega C_X} = \frac{1}{\omega C_A} - \omega(L_O + L_W) \quad (34)$$

where C_A = the absolute capacitance

L_O = the self-inductance

L_W = the lead inductance.

In the great majority of cases, a knowledge of the effective capacitance is required in order to assess the performance of the capacitor in a particular circuit at a particular frequency. There are occasions, however, when it is desirable to separate the capacitive and inductive components. This can be achieved by measuring C_O at two frequencies; often it is convenient to make one of the measurement frequencies equal to the natural frequency of the capacitor where this frequency lies within the range of the oscillator.

If one of the test frequencies is arranged to be the natural frequency of the capacitor, the measurement procedure is as set out in Section 5.2.4. If one of the test frequencies selected is not the natural frequency of the capacitor, then the procedure is as follows.

Measure the effective capacitance at any two frequencies by either of the methods described previously. The greater the difference between the two frequencies, the better the measurement accuracy.

The self-inductance of the capacitor under test plus the inductance of any connecting leads is then given by

$$L_O + L_W = \frac{1}{\omega_1^2 - \omega_2^2} \left\{ \frac{1}{C_{X_2}} - \frac{1}{C_{X_1}} \right\} \quad (35)$$

and the absolute capacitance is given by

$$C_A = \frac{C_{X_1}}{1 + \omega_1^2 (L_O + L_W) C_{X_1}} \quad (36)$$

where C_{X_1} = the effective (measured) capacitance at a frequency of ω_1 radians/sec

C_{X_2} = the effective (measured) capacitance at a frequency of ω_2 radians/sec

5.2.4 ABSOLUTE CAPACITANCE AND SELF-INDUCTANCE—NATURAL FREQUENCY METHOD

- (1) Measure the effective capacitance, by either of the methods described previously, at a frequency which is known to be less than the natural frequency of the capacitor under test. Let the measured capacitance be C_X and the frequency f_1 .
- (2) Increase the test frequency and determine the frequency at which the addition of the

capacitor under test causes no change in the resonating capacitance required to maintain resonance. Let this frequency be f_0 .

The test circuit is now tuned to the natural frequency of the capacitor under test. The absolute capacitance of the capacitor is then given by

$$C_A = C_X \left[1 - \left(\frac{f_1}{f_0} \right)^2 \right] \dots\dots\dots (37)$$

and the self-inductance by

$$L_0 = \frac{1}{C_X (\omega_0^2 - \omega_1^2)} \dots\dots\dots (38)$$

5.2.5 SELF-INDUCTANCE—DIRECT-CONNECTION METHOD

The self-inductance of large capacitors can be measured at a frequency well above their natural frequency. At the test frequency the reactance of the capacitor is largely inductive and the capacitor is treated as though it were an inductor. No circuit resonating inductor is used; the capacitor is con-

nected directly between the HI and LO terminals of the test circuit.

For this measurement it is necessary to eliminate the inductance of the capacitor leads. This is done by making use of stable clip leads and a 'shorting' strip—described in Section 4.3.6.

The measurement procedure is as follows:—

- (1) Connect the capacitor under test to the HI and LO terminals by means of the stable clip leads.
- (2) Connect a high-value resistor—about 1 MΩ—between the HI and E terminals: this is to retain the d.c. path between the Q AND δQ meter input diode and earth.
- (3) Resonate the test circuit at a frequency known to be well above the natural frequency of the capacitor.

Let the indicated capacitance at resonance be C_2 and the frequency be f .

- (4) Replace the capacitor under test by the 'shorting' strip.

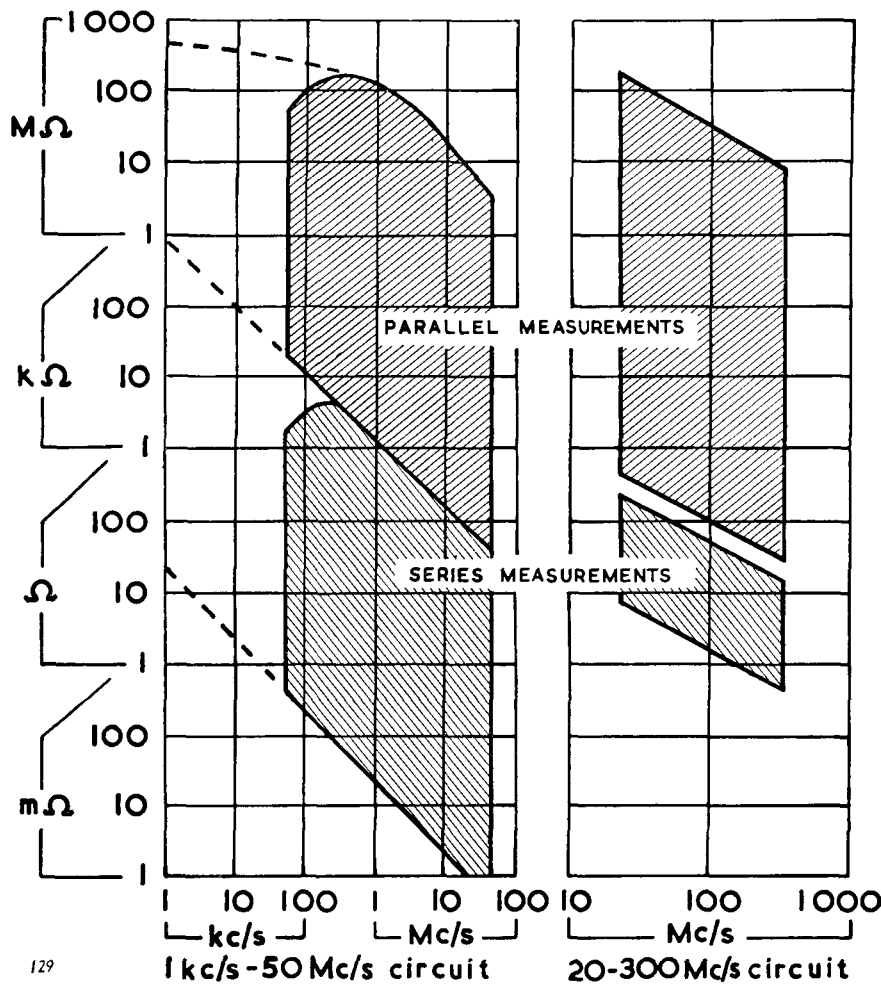

Fig. 5.3 Resistance Measurement Range.

- (5) Resonate the test circuit by means of the tuning capacitor control. Let the new indicated capacitance at resonance be C_1 .

The self-inductance of the capacitor is given by

$$L_o = \frac{1}{(2\pi f)^2} \left\{ \frac{C_1 - C_2}{C_1 C_2} + \frac{1}{C_X} \right\} + L_s \quad (39)$$

where C_X = the capacitance of the capacitor under test; it is sufficiently accurate to use the nominal value of capacitance in this expression.

L_s = the inductance of the 'shorting' strip and is calculated from expression 11—Section 4.3.0.

5.3 MEASUREMENTS ON RESISTORS

5.3.1 INTRODUCTION

Measurements on resistors can be made by connecting the resistor under test either in series or in parallel with the test circuit; the method of connection used depends (i) on the frequency of test and (ii) on the value of the resistance.

Fig. 5.3 shows the resistance measurement range for both series and parallel connection. The areas enclosed by solid lines show the measurement range using the TM 1438 series and TM 4947 series of inductors. The dotted lines indicate the extended range, down to 1 kc/s, using inductors whose inductance is greater than those of the TM 1438 series.

5.3.2 R AND C—LARGE-VALUE RESISTORS

Measurements are made on large-value resistors by connecting them in parallel with the test-circuit capacitor. For details of the measurement range, see Section 5.3.1.

- (1) Connect a suitable resonating inductor to the HI and LO terminals.
- (2) Adjust the oscillator frequency and tuning capacitance to resonate the test circuit. Let the indicated capacitance at resonance be C_1 and the indicated Q reading be Q_1 .
- (3) Connect the resistor under test to the HI and E terminals.

* In general, it is sufficient to use the indicated value of the tuning capacitance. Strictly, the **effective** value should be used. Graphs of effective value against indicated value of tuning capacitance are given in Figs. 10.2 and 10.3 at the end of this handbook.

- (4) Resonate the test circuit by means of the tuning capacitor. Let the indicated capacitance at resonance be C_2 and the indicated Q reading be Q_2 .

The effective shunt resistance of the resistor under test at the frequency of test is given by

$$R_{XP} = \frac{Q_1 Q_2}{Q_1 - Q_2} \frac{1}{\omega(C_1^*)} \quad (40)$$

The effective shunt self-capacitance is given by

$$C_{XP} = C_1^* - C_2^* \quad (41)$$

If C_{XP} is negative, then the measurement has been made at a frequency greater than the natural frequency of the resistor. The effective shunt self-inductance is then given by

$$L_{XP} = \frac{1}{\omega^2 C_{XP}} \quad (42)$$

5.3.3 R AND C—SMALL-VALUE RESISTORS

Measurements are made on small-value resistors by connecting them in series with the test circuit. For details of the measurement range, see Section 5.3.1. In this method the Series Loss Test Jig TJ 230 is used (for details, see Section 1.2).

- (1) Connect the Series Loss Test Jig to the I f test circuit terminals (see Section 2.4.5).
- (2) Connect the resistor under test to the jig.
- (3) Connect a suitable resonating inductor to the jig.
- (4) Short circuit the resistor under test by means of the screw switch.
- (5) Resonate the test circuit by means of the oscillator frequency and the tuning capacitance. Let the indicated tuning capacitance at resonance be C_1 and the indicated Q reading be Q_1 .
- (6) Bring the resistor under test into circuit by unscrewing the screw-switch.
- (7) Resonate the test circuit by means of the tuning capacitor. Let the indicated capacitance at resonance be C_2 and the indicated Q reading be Q_2 .

The effective series resistance of the resistor under test at the frequency of test is given by

$$R_X = \frac{1}{\omega} \left\{ \frac{1}{C_2 Q_2} - \frac{1}{C_1 Q_1} \right\} \quad (43)$$

The effective series self-capacitance is given by

$$C_X = \frac{C_1 C_2}{C_2 - C_1} \quad (44)$$

To convert expressions (43) and (44) to the more usual parallel combination, the following ex-

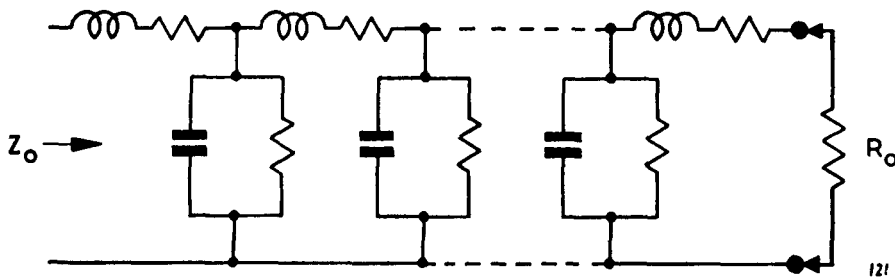

Fig. 5.4 Equivalent Circuit of a Transmission Line.

pressions should be used:—

$$R_{XP} = \frac{1 + (\omega C_X R_X)^2}{(\omega C_X)^2 R_X}$$

$$C_{XP} = \frac{C_X}{1 + (\omega C_X R_X)^2}$$

If C_{XP} is negative, the measurement has been made at a frequency greater than the natural frequency of the resistor. The effective shunt inductance is then given by

$$L_{XP} = \frac{1}{\omega^2 C_{XP}} \dots\dots\dots(45)$$

5.4 MEASUREMENTS ON TRANSMISSION LINES

5.4.1 INTRODUCTION

The characteristic impedance, attenuation, and phase velocity of a transmission line can be determined by open- and short-circuit measurements on the line. The equivalent circuit of a line is shown in Fig. 5.4.

If the end of the line is open-circuit, the effective circuit can be considered as a single capacitance C_d in parallel with a single conductance G_d . The effective shunt admittance is $G_d + j\omega C_d$ mhos.

If the line is short-circuited, the effective circuit can be considered as a single inductance L_s in series with a single resistance R_s . The effective series impedance is $R_s + j\omega L_s$ ohms.

The characteristic impedance is then given by

$$Z_0^2 = \frac{\text{Effective short-circuit series impedance}}{\text{Effective open-circuit shunt admittance}} \dots\dots\dots(46)$$

From a knowledge of the four components mentioned above, all the characteristics of a transmission line can be calculated provided that the electrical length of the line is short compared with a half-wavelength. In practice, when making measurements by the methods described in Sections 5.4.2 and 5.4.3, the electrical length of the line should be as short as possible; the maximum practical length to use is about one-eighth wavelength. Fig. 5.5 gives a graph of $\lambda/8$ against frequency; the values are calculated from the expression.

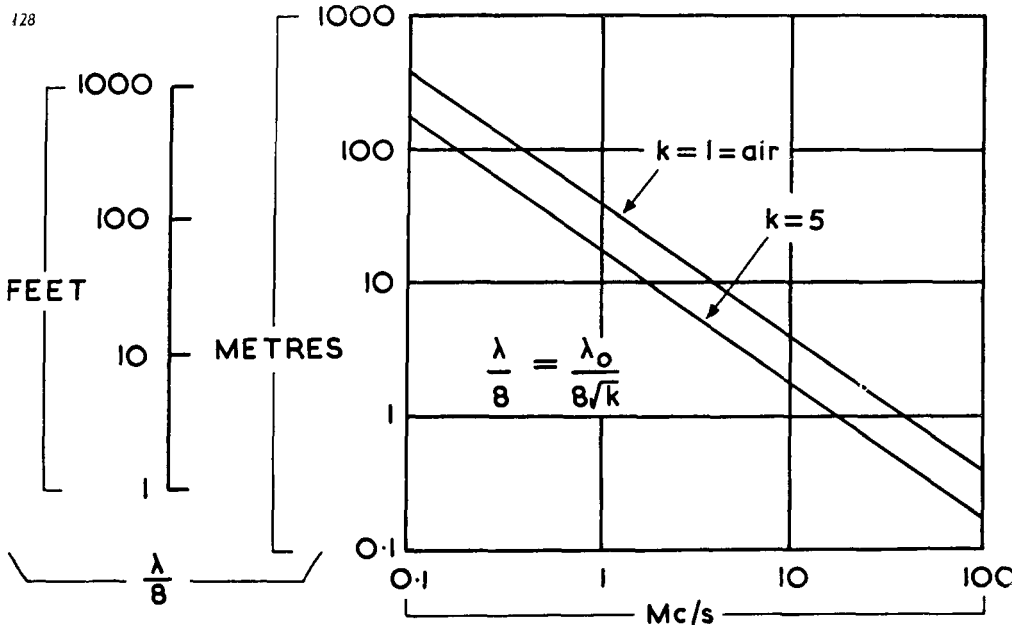

Fig. 5.5 Variation of the Electrical Length of a Transmission Line with Dielectric Constant.

copper strip; Fig. 4.8 shows a method of construction. The way in which the component is held is also shown in the diagram. The 'shorting' strip should be fabricated from stiff copper strip, its length is dependent on the dimensions of the component under test; the recommended dimensions are 0.5 in. wide by 0.01 in. thick with about $\frac{1}{8}$ in. folded down at each end. The inductance of the strip is given by

$$L_s = 0.002D \left\{ 2.303 \log_{10} \frac{2D}{b+c} + 0.5 + 0.2235 \frac{b+c}{D} \right\} \dots\dots\dots(11)$$

where L_s is in μH

- D = length of the strip in cm.
- b = width of the strip in cm.
- c = thickness of the strip in cm.

When using the arrangement described above, the measurement procedure is exactly as detailed in the appropriate section dealing with series measurements except that the component under test is not shorted out by means of the screw-switch; instead, it is replaced by the 'shorting' strip. The true reactance of the component under test is then given by the algebraic sum of the measured reactance and the reactance of the 'shorting' strip. For resistance measurements, no allowance for the 'shorting'

strip need be made; fundamentally, this is not strictly true but the error incurred can be considered negligible.

4.3.7 SUMMARY

In theory, the Q-Meter indicates the Q of the complete circuit; in practice this is not so because of the inductor self-capacitance. The tuning-capacitor dial always indicates the capacitance that exists between the capacitor plates. Strictly, a measured result should not be taken to be the true value, whether it be Q, L, C, or R, of the component under test. More often than not, the measured result is a close approximation to the true result because the residual components are designed to have as little effect on the circuit as possible. The user should always consider the possibility of corrections when making a measurement; this applies particularly at the highest frequencies and at the highest capacitance settings.

To summarize the preceding sections, when making a Q-Meter measurement, the following factors should be borne in mind:—

- (1) *Self-Capacitance of component under test.* This is by far the most important correction. (See Section 4.3.1.)
- (2) *Circuit Capacitor Losses.* It must be remembered that although the capacitor Q is arranged

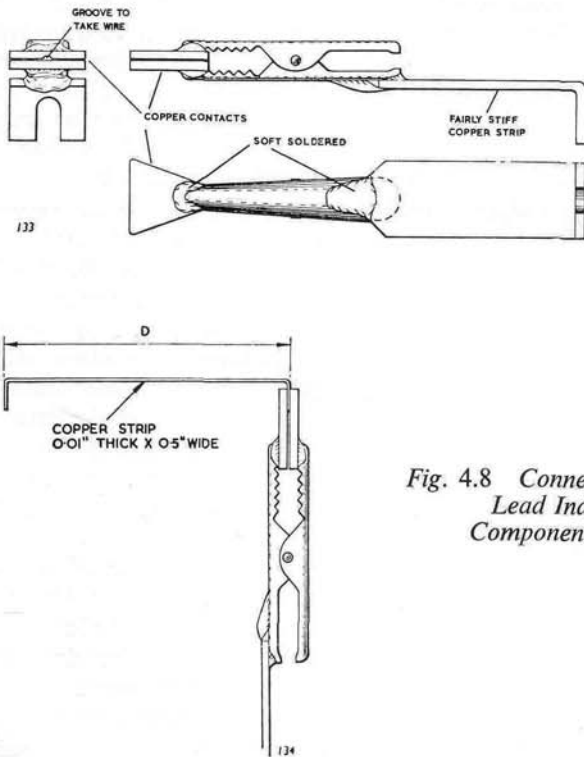
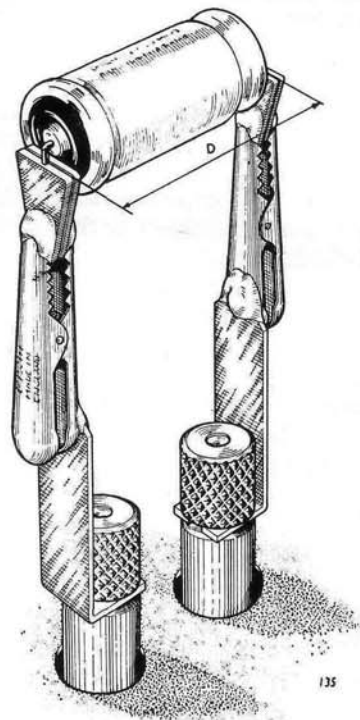

Fig. 4.8 Connectors to Eliminate Lead Inductance of Component under Test.



by the diode load resistor of a shunt circuit would be greater than that of the diode itself. There is, however, one limitation in the series circuit which has been used, a d c path is required in the resonant circuit under test. This path is generally supplied by the resonating inductor but in cases where, say, the L_o of a capacitor is being measured and the 'inductor' has no d c continuity, a d c path must be supplied by a suitable coil of large inductance or a resistor connected in parallel with the test component across the inductor terminals.

For good discrimination the panel meter is calibrated in three Q Ranges—50, 150 and 500—corresponding to full-scale deflections of 1, 3 and 10 volts respectively. The δQ facility gives an expanded Q scale of 25-0-25 anywhere in the Q range, the d c output from the diode is backed off in steps of 50 Q with a stabilized d c voltage derived from V2 via the switched potentiometer chain R6 to R15. This d c voltage is applied to the grid of one of the d c bridge triodes (V3b) and, in effect, shifts the bridge zero by the required amount.

6.5 POWER SUPPLY

Both the h t and l t supplies to the valve voltmeter are stabilized against variations in mains input voltage. The valve heaters are fed from a special transductor stabilizer circuit designed to give a constant r m s current instead of the constant average current common to simple (non-feedback) magnetic amplifiers. The h t supply to the d c bridge and the δQ backing-off voltage are both derived from reference neon stabilizers.

Since all valve supplies in the instrument are stabilized the instrument can be operated from a wide range of mains voltages without recourse to a multi-tapped mains transformer primary. Earlier models merely have the two primary windings connected in series for 190- to 260-volt operation, and in parallel for 95- to 130-volt operation. In order to improve the regulation, however, later models have extra taps which halve the major ranges to give ranges of 190- to 230-volts, 220- to 260-volts, 95- to 115-volts, and 110- to 130-volts.

7 MAINTENANCE

7.1 GENERAL

It is strongly recommended that the user should become familiar with the contents of Section 6 before commencing the adjustment or replacement of component parts of the instrument.

It should also be remembered that the TF 1245 is a precision instrument and its calibration at the factory is dependent upon the use of specialized test equipment and techniques. The maintenance information given here will enable simple component failures to be rectified, but for any major fault or damage the repair and recalibration should only be carried out by the manufacturer. In this event the instrument should be returned to Marconi Instruments Ltd., Service Division, Hedley Road, St. Albans, Herts., England.

The circuit diagram, Fig. 10.6, shows all the electrical components contained in the instrument

and also gives their values. The descriptions of these components—their types, tolerances, ratings, etc.—are given in the Spares Ordering Schedule; this Schedule also lists certain selected mechanical components.

The physical locations of the electrical components are shown in the Component Layout Illustrations.

7.2 MAINS TRANSFORMER ADJUSTMENT

To get at the mains transformer remove the top and back panels (see Section 7.4).

Compare the transformer link arrangements, as viewed from the rear of the instrument, with Figs. 7.1 and 7.2. For earlier models not having the intermediate taps, use the connections shown in Figs. 7.1(b) and 7.2(b).

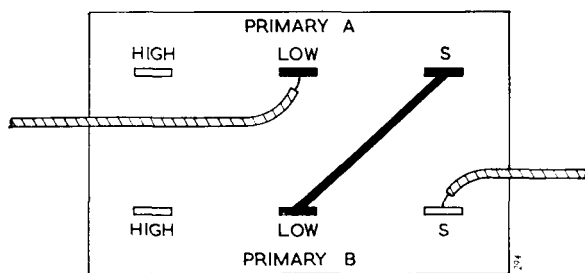

(a) for 190- to 230-volt range.

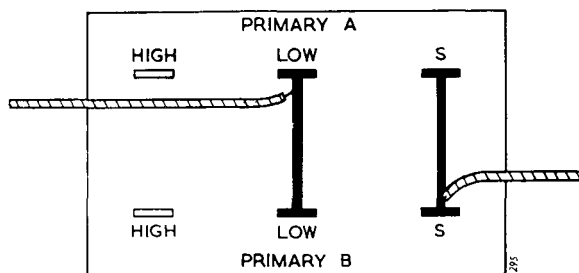

(a) for 95- to 115-volt range.

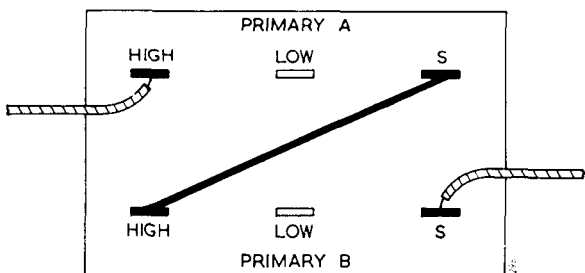

(b) for 220- to 260-volt range.

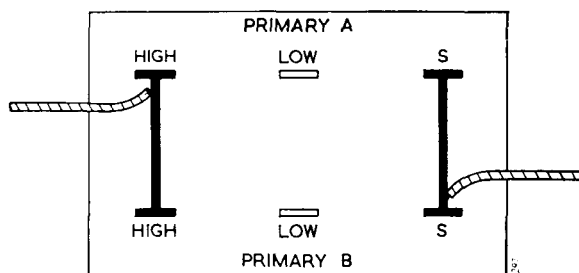

(b) for 110- to 130-volt range.

Fig. 7.1 190- to 260-volt Connections.

Fig. 7.2 95- to 130-volt Connections.

190- to 260-volt range.

Only one link is used, as shown in Fig. 7.1; this connects the two primary windings in series.

95- to 130-volt range

Two links are used as shown in Fig. 7.2; these connect the two primary windings in parallel.

7.3 FUSES

The TF 1245 is protected by two fuses. One is in series with the mains transformer primary and the other is in series with the h t secondary. Both are standard 1-in long, $\frac{1}{4}$ -in diameter cartridge fuses. The fuse in the primary is rated at 1 amp for 190- to 260-volt mains and 2 amp for 95- to 130-volt mains working, the fuse in the secondary is 150 mA. Both fuses are accessible at the rear of the instrument and can be replaced without removing the instrument rear cover.

7.4 ACCESS TO COMPONENTS

To remove Case Panels —

- (1) Detach the case top-panel by undoing the four screws at its edge holding it to the top of the instrument.
- (2) Detach the rear case-panel after detaching four screws, two of the screws hold the panel to the rear of the instrument and the remaining two are on the underside at the rear.
- (3) Detach the bottom case-panel by undoing the two screws at its front-panel edge holding it to the bottom of the instrument.

7.5 WORKING VOLTAGES

The voltages given in Table 1, for guidance when servicing the instrument, were obtained from a representative TF 1245, the voltmeter used was an Avometer Model 8, which has a resistance of 20,000 ohms/volt. The voltages were measured with 240 volts applied to the mains transformer, on the 190- to 260-volt range.

TABLE 1

All measurements except the transformer-secondary voltages were made with respect to the h t negative line.

H T Secondary (between tags on mains transformer)	110 V a c
L T Secondary (between tags on mains transformer)	27 V a c
H T Rectified (junction of MR1 and C1)	250 V d c
HT1 (pin 1, V1)	150 V d c
HT2 (pin 5, V2)	83 V d c
V3 cathode voltages (pins 3 and 8)	73 V d c

7.6 REPLACEMENT OF VALVES

The types of valves used in the instrument, their base connections, and some guidance as to suitable

alternatives if the types originally fitted are not readily available, are given in Table 2 on page 42.

The valves may normally be replaced without special selection. V1, V2 and V3 are immediately accessible on removing the top case-panel as described in Section 7.4 (1). Access to V4 is described in Section 7.6.1.

When replacing the voltmeter valves, V3 and V4, it is advisable to age new valves for about 100 hours at their normal working voltages before making any calibration adjustments.

7.6.1 REMOVAL OF Q AND δ Q METER INPUT DIODE V4

- (1) Remove the case panels as described in Section 7.4. At the rear of the tuning-capacitor-assembly casting are two plastic dust covers, one large one small, and a U-section metal bracket which supports the diode.
- (2) Remove the large plastic cover by undoing the four screws holding it to the casting.
- (3) Remove *carefully* the bracket after undoing the four screws holding it to the casting.
- (4) Unsolder the two diode heater wires.
- (5) Unsolder the cathode resistor from its feed-through capacitor. The diode is held in position by a U-section clamp plate. Under the cathode band is trapped a metal plate and a mica sheet which, together, form the by-pass capacitor C4. Special care should be taken to ensure that the mica is not damaged by removal of the valve.
- (6) Unscrew the two nuts and bolts which hold the diode-cathode band to the bracket. Make sure the spacers do not fall out and get lost.

The diode can then be withdrawn from its mounting assembly.

To reassemble the diode, reverse the order given above. When fitting the assembly to the casting, the following points must be observed:

- (a) The two contact fingers which protrude from the bracket must be clean and must locate in the grooves in the capacitor spindle. The correct grooves are those which lie *between* the first and second rotor vanes at either end of the set.
- (b) The diode anode pin must locate properly on the anode connector strip. Do not allow the end of the strip to jam against the side of the anode pin.
- (c) Ensure that the mica sheet is not shorted out.

TABLE 2

Any valve which becomes faulty should preferably be replaced by a valve of the type originally supplied in the instrument. If this is not possible the additional data given by the table may be used as a guide to suitable alternatives.

<i>Valve</i>	<i>Type</i>	<i>Base</i>	<i>British Commercial Equivalent</i>	<i>British Services Equivalent</i>	<i>U.S. Equivalent</i>
V1	Brimar OA2 Voltage Stabilizer	a	150C4 QS1207	CV1832	OA2
V2	Mullard 85A2 Voltage Stabilizer	a	QS83/3 M8098† 5651	CV449 CV4048	OG3
V3	Brimar 12AU7 Double Triode	b	ECC82 B329 6067† M8136†	CV491 CV4003	12 AU7
V4	Mullard EA52 Diode	c	—	CV5140	EA52 is available in U.S.A. from Marconi Instruments, New Jersey

† *High reliability type.*

a

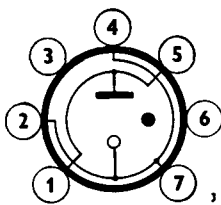

(B7G)

b

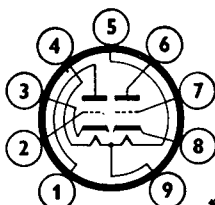

(B9A)

c

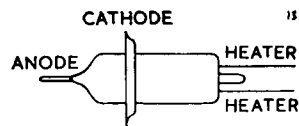

7.7 PRESET COMPONENTS

During the factory calibration of the instrument, certain of its performance characteristics are brought within close limits by means of preset components.

Following the replacement or ageing of certain fixed components, it may become necessary to repeat part of the calibration procedure by which the presets were adjusted.

7.7.1 INJECTION POTENTIOMETERS

The l.f. test circuit injection potentiometer, consisting of R27 and R26, is accurately adjusted during manufacture. Likewise the h.f. injection potentiometer, L2 and L1, is accurately preset to the required ratio of 25:1 by adjustment of L2. No attempt should be made by the user to readjust these components—see Section 7.1.

7.7.2 ADJUSTMENTS OF PRESETS

The circuit references of certain preset components are given in Table 3, together with their circuit function and the numbers of the sections describing their readjustment.

Preset Component	Adjustment Function	Section Describing Adjustment
RV1	Heater current	7.8.3
RV3)	δQ accuracy	7.8.5
RV5)		
RV9)		
RV6	Q accuracy	7.8.4
RV7)	Q MULTIPLIER accuracy	7.8.6
RV8)		

7.8 SCHEDULE OF TESTS

The following information is based on extracts from the internal Factory Test Schedule.

7.8.1 APPARATUS REQUIRED

- 750-volt Insulation Tester.
- Variable Mains Transformer, e.g. Variac.
- Voltmeter, true r.m.s. to measure at least 6.3 volts.
- Oscillator to provide 10 volts r.m.s. at 5 kc/s, e.g. Marconi type TF 1101, TF 195 (Series), TF 894A or TF 885 (Series).
- Valve Voltmeter, standardized, e.g. Marconi Type TF1300, TF1041 (Series) or TF428 (Series).
- High resistance d.c. voltmeter, standardized, e.g. Avometer Model 8.
- Oscillator, Marconi Type TF 1246.

- Oscillator, Marconi Type TF 1247.
- A.C. Millivoltmeter, standardized, to measure 20mV at 1 and 50 Mc/s.
- Capacitance Bridge, $\pm 0.25\%$, e.g. Marconi Type TF 1342.

7.8.2 INSULATION

(Apparatus required: Item a)

Measure the insulation resistance between chassis and each 'live' pin of the mains supply plug with the SUPPLY switch ON. The reading should normally be approximately 40 MΩ or above.

7.8.3 HEATER CURRENT

(Apparatus required: Items b and c)

The valve-heater supply stabilizer is set up by adjusting RV1 to give the correct voltage across the heater of V4.

- Monitor the voltage at the secondary of the isolating transformer, T3, with the r.m.s. voltmeter.
- With the TF 1245 mains transformer set to the appropriate range connect the Q Meter to the mains via the variable transformer. Set the input voltage to the centre of the range; see Section 7.2.
- Adjust RV1 to give a heater voltage of 6.3 volts.
- It may be necessary to add a resistor across the primary of T3, in order to increase the stabilizer current to ensure that V3 heater also has 6.3 volts across it.

7.8.4 Q RANGE ACCURACY

(Apparatus required: Items d and e)

- After allowing the instrument to warm up for 20 mins. short the HI and E terminals of the h.f. test circuit. (Link LKA need not be fitted.)
- Set the Q RANGE switch to 50 and adjust the Q SET ZERO control to bring the Q AND δQ meter pointer to zero.
- Remove the short and connect the oscillator across the HI and E terminals.
- Apply a signal of 1.0 volt r.m.s. at 5 kc/s, monitored by the standardized valve voltmeter.
- Adjust RV6 to give full-scale deflection on the Q AND δQ meter.
- Turn the Q RANGE switch to 150 and check that an input of 3.0 volts r.m.s. gives full-scale deflection within $\pm 2\%$.
- Turn the Q RANGE switch to 500 and check that an input of 10.0 volts r.m.s. again gives full-scale deflection within $\pm 2\%$.

If the error on the 150 or 500 ranges is greater than $\pm 2\%$, RV6 should be adjusted to give the best overall compromise accuracy

7.8.5 δQ RANGE ACCURACY

(Apparatus required Items d, e, and f)

Adjustment of RV3 and RV5 gives the correct backing - off voltage and meter sensitivity, respectively, for the δQ ranges. RV9 may need to be adjusted to centralize the Q ZERO control after adjustment of RV3, soften the vinyl cement on the slider with a solvent such as acetone

- (1) Connect the high resistance d.c. voltmeter across any one of the 1 k Ω resistors R6 to R15
- (2) Adjust RV3 to give a reading of 1.36 volts on the d.c. voltmeter
- (3) Set the Q RANGE switch to δQ
- (4) Connect the oscillator to the h.f. test circuit HI and E terminals, with the standardized valve voltmeter to monitor the oscillator output
- (5) Set the oscillator output to 5 volts r.m.s. at 5 kc/s
- (6) Adjust the δQ FINE and COARSE ZERO controls until the Q AND δQ meter pointer indicates '—25,' (i.e. left-hand zero)
- (7) Increase the oscillator output to 6 volts
- (8) Adjust RV5 until the Q AND δQ meter pointer indicates '+25' (i.e. full-scale right-hand deflection)

7.8.6 Q MULTIPLIER METER ACCURACY

(Apparatus required Items g, h, and i)

The sensitivity of the crystal voltmeter circuits used to monitor the injection input signals are set up by adjustment of RV7 and RV8

- (1) Connect the TF 1246 Oscillator to INPUT I. Set its frequency to 1 Mc/s
- (2) Connect the standardized a.c. millivoltmeter to the I f test circuit LO and E terminals
- (3) Adjust the oscillator output until the millivoltmeter reads 20 mV
- (4) Adjust RV8 to bring the Q MULTIPLIER meter pointer to the $\times 1$ mark

Similarly, for the h.f. test circuit —

- (1) Connect the TF 1247 Oscillator, set to about 50 Mc/s, to INPUT II

- (2) Connect the millivoltmeter to the h.f. test circuit LO and E terminals
- (3) Adjust the oscillator output until the millivoltmeter reads 20 mV
- (4) Adjust RV7 to bring the Q MULTIPLIER meter pointer to the $\times 1$ mark

If it is found that RV7 or RV8 have insufficient cover to enable the Q MULTIPLIER meter to be set up, the appropriate meter diodes MR3/MR4 or MR5/MR6 should be tested. Measured with an Avometer Model 8, their reverse resistance should not be less than 10 k Ω .

7.8.7 TUNING CAPACITOR CALIBRATION ACCURACY

(Apparatus required Item j)

Check the accuracy of the tuning-capacitor dial calibration as follows:—

- (1) For the I f test circuit, connect link LKA between the HI I and HI II terminals. Screw the LO terminal into its upper socket. Connect the capacitance bridge across the right-hand HI and E terminals. The calibration accuracy of the main dial should be within $\pm 1 \mu\mu\text{F} \pm 1\%$, that of the increment dial should be within $\pm 0.2 \mu\mu\text{F}$
- (2) For the h.f. test circuit, disconnect link LKA. Connect the capacitance bridge across the left-hand HI and E terminals. The calibration accuracy of the main dial should be within $\pm 0.5 \mu\mu\text{F} \pm 1\%$, that of the incremental dial should be within $\pm 0.1 \mu\mu\text{F}$

If the calibration accuracy is found to be outside the above limits a correction chart should be made or, if preferred, blank dials fitted and the capacitor recalibrated. In the event of gross inaccuracy or suspected mechanical derangement the user should not attempt to rectify the fault, the instruments should then be returned to the manufacturer for servicing—see Section 7.1

7.8.8 INDICATED Q ACCURACY

The accuracy of the Q factor indicated by the Q AND δQ meter may be checked by using the incremental capacity method,

$$Q = \frac{2C}{\delta C}$$

where C is the tuning capacitance for resonance, and δC is the change in C between the two half-power points, i.e. $0.707 \times \text{Peak Q Reading}$ (see Section 5.1.2)

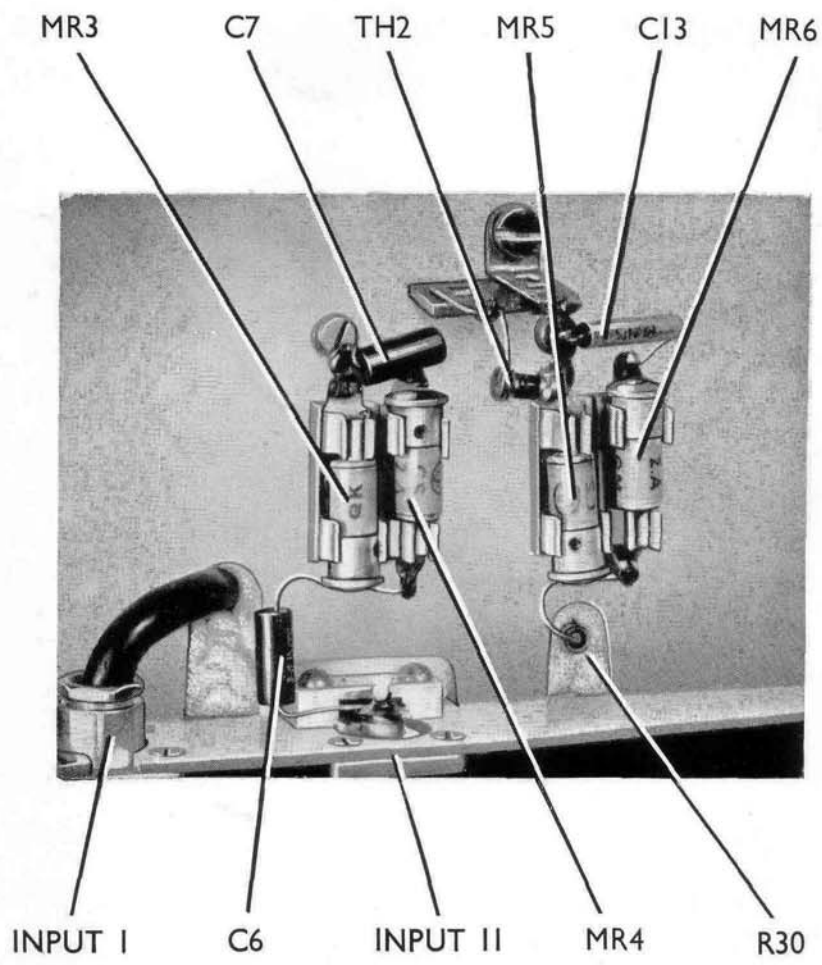

VIEW FROM TOP

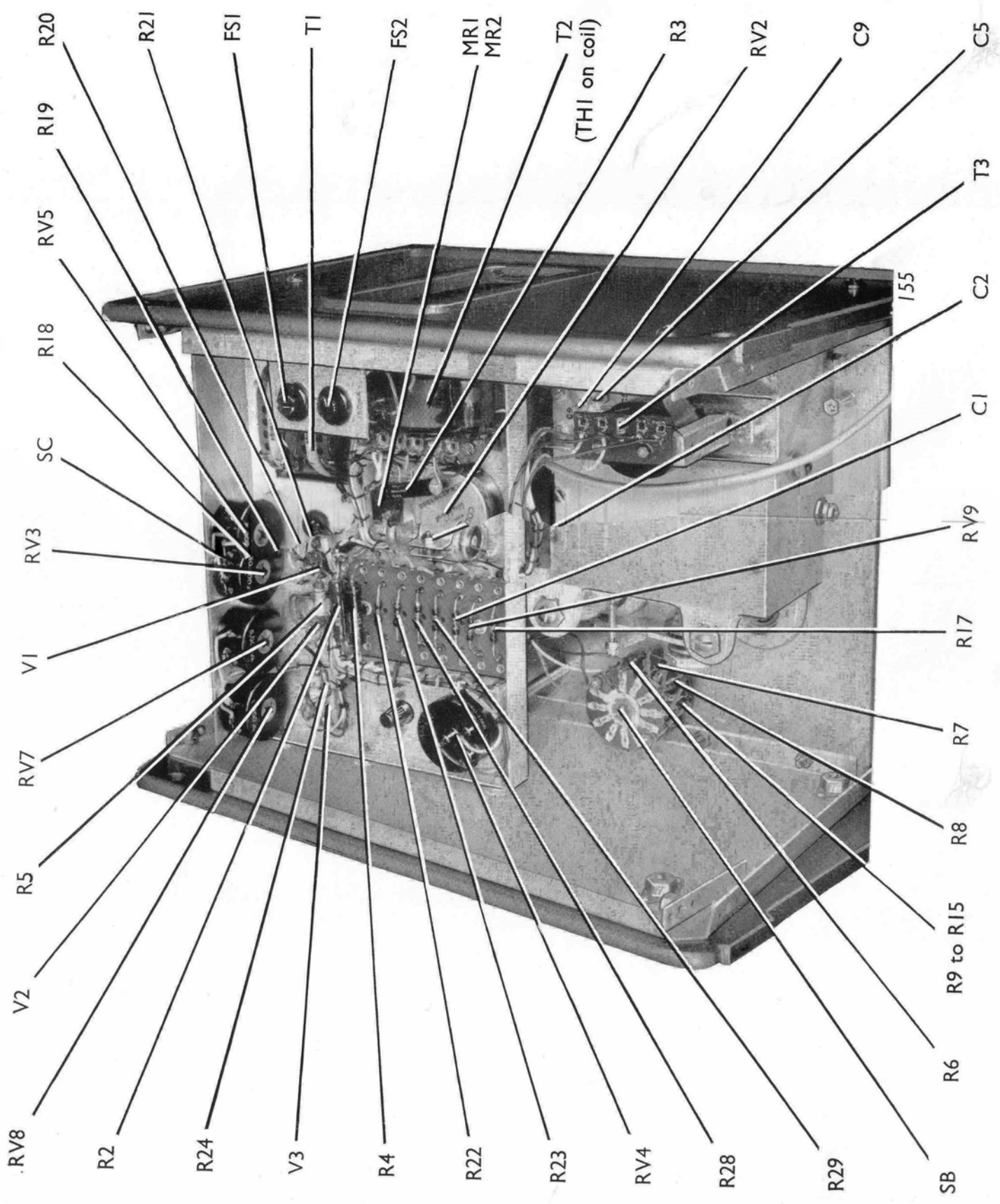

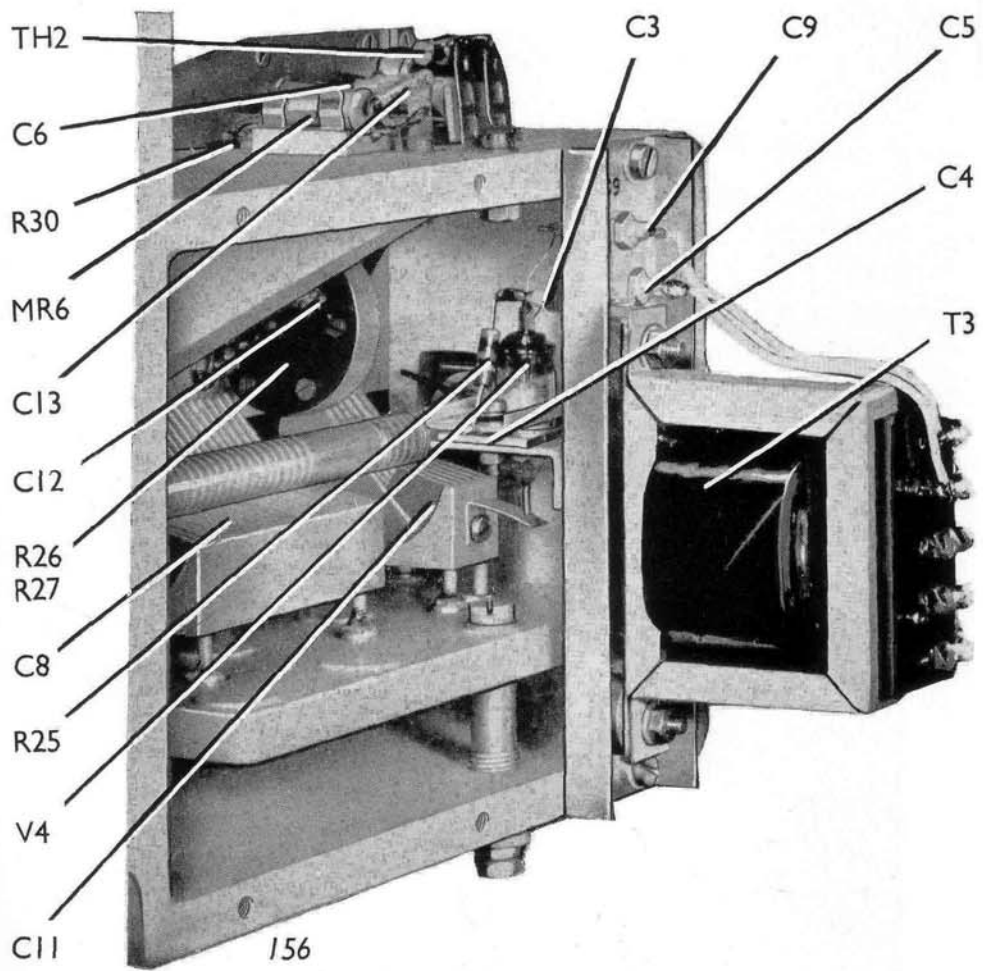

INTERIOR VIEW FROM REAR

9 SPARES ORDERING SCHEDULE

When ordering replacement parts, always quote the TYPE NUMBER and SERIAL NUMBER of the instrument, the QUANTITY required and the appropriate SOS ITEM NUMBER

For example, to order replacements for the 15-k Ω resistor, R5, and the 8- μ F capacitor, C2, quote as follows:—

Spares required for TF 1245, Serial No. 000000

1 off, SOS Item 4

1 off, SOS Item 43

It is important that the distinguishing code 'SOS' preceding each item number should not be omitted

<i>SOS Item No</i>	<i>Circuit Ref.</i>	<i>Description</i>	<i>Works Ref.</i>
RESISTORS			
1	R2	Wirewound, 4.7 k Ω \pm 10%, 10 W.	5-TM4943BA
2a	R3	Carbon, High Stability, 22 k Ω \pm 2%, 1 W.	27-TM5642
3a	R4	Carbon, High Stability, 5 k Ω \pm 5%, 1 W.	6-TM4943BA
4	R5	Composition, 15 k Ω \pm 10%, $\frac{1}{2}$ W.	PC66611/39
5	R6	Carbon, High Stability, 1 k Ω \pm 1%, $\frac{1}{4}$ W.	2-TM5643
6	R7	Carbon, High Stability, 1 k Ω \pm 1%, $\frac{1}{4}$ W.	2-TM5643
7	R8	Carbon, High Stability, 1 k Ω \pm 1%, $\frac{1}{4}$ W.	2-TM5643
8	R9	Carbon, High Stability, 1 k Ω \pm 1%, $\frac{1}{4}$ W.	2-TM5643
9	R10	Carbon, High Stability, 1 k Ω \pm 1%, $\frac{1}{4}$ W.	2-TM5643
10	R11	Carbon, High Stability, 1 k Ω \pm 1%, $\frac{1}{4}$ W.	2-TM5643
11	R12	Carbon, High Stability, 1 k Ω \pm 1%, $\frac{1}{4}$ W.	2-TM5643
12	R13	Carbon, High Stability, 1 k Ω \pm 1%, $\frac{1}{4}$ W.	2-TM5643
13	R14	Carbon, High Stability, 1 k Ω \pm 1%, $\frac{1}{4}$ W.	2-TM5643
14	R15	Carbon, High Stability, 1 k Ω \pm 1%, $\frac{1}{4}$ W.	2-TM5643
16	R17	Carbon, High Stability, 33 k Ω \pm 5%, $\frac{1}{4}$ W.	13-TM4943BA
17	R18	Carbon, High Stability, 4.7 k Ω \pm 5%, $\frac{1}{4}$ W.	2-TM5644
18	R19	Carbon, High Stability, 118 k Ω \pm 1%, $\frac{1}{4}$ W.	3-TM5644
19	R20	Carbon, High Stability, 28 k Ω \pm 1%, $\frac{1}{4}$ W.	4-TM5644
20	R21	Carbon, High Stability, 2 k Ω \pm 1%, $\frac{1}{4}$ W.	5-TM5644
21	R22	Carbon, High Stability, 330 k Ω \pm 5%, $\frac{1}{4}$ W.	7-TM4943BA
22	R23	Carbon, High Stability, 330 k Ω \pm 5%, $\frac{1}{4}$ W.	8-TM4943BA
23	R24	Carbon, High Stability, 100 M Ω , Welwyn H.11.	25-TM5642
24	R25	Composition, 100 Ω \pm 10%, $\frac{1}{4}$ W.	PC66609/7
25	{R26 R27}	{Special, 0.02 Ω . Special, 0.48 Ω }	1-TM5641

SECTION 9

<i>SOS Item No.</i>	<i>Circuit Ref.</i>	<i>Description</i>	<i>Works Ref.</i>
26	R28	Carbon, High Stability, 6.8 k Ω \pm 5%, $\frac{1}{4}$ W.	9-TM4943BA
27	R29	Carbon, High Stability, 6.8 k Ω \pm 5%, $\frac{1}{4}$ W.	10-TM4943BA
28	R30	Composition, 47 Ω \pm 10%, $\frac{1}{4}$ W.	66-TM5639
29	R32	Carbon, High Stability, 3.3 k Ω \pm 5%, $\frac{1}{4}$ W.	11-TM4943BA

THERMISTORS

30	TH1	Brimistor, Type CZ3, 1.5 k Ω \pm 20%, at 20°C.	6-TM5645
31	TH2	Brimistor, Type CZ3, 1.5 k Ω \pm 20%, at 20°C.	68-TM5639

POTENTIOMETERS AND KNOBS

32	RV1	Wirewound, 5 k Ω \pm 10%, 3 W, Linear.	28-TM5642
33	RV2	Wirewound, 500 Ω \pm 10%, 1 W, Linear.	29-TM5642
34	RV3	Wirewound, 30 k Ω \pm 10%, 3 W, Linear.	30-TM5642
35	RV4	Carbon, 1 M Ω \pm 20%, $1\frac{1}{2}$ W, Linear.	31-TM5642
36	RV5	Wirewound, 5 k Ω \pm 10%, 3 W, Linear.	28-TM5642
37	RV6	Wirewound, 5 k Ω \pm 10%, 3 W, Linear.	28-TM5642
38	RV7	Wirewound, 5 k Ω \pm 10%, 3 W, Linear.	28-TM5642
39	RV8	Wirewound, 5 k Ω \pm 10%, 3 W, Linear.	28-TM5642
39/1	RV9	Wirewound, 1 k Ω \pm 10%, $\frac{1}{2}$ W, Linear.	12-TM4943/CU
40		Knob for RV2.	TB23920/1
41		Knob for RV4.	TB17848/3

CAPACITORS

42	C1	Electrolytic, 8 μ F + 50% — 20%, 450 V d.c.	35-TM5642
43	C2	Electrolytic, 8 μ F + 50% — 20%, 450 V d.c.	35-TM5642
44	C3	Feed-through, 4700 μ μ F, 500 V d.c.	75-TM5639
45	C4	Mica, 20 μ μ F, Special.	16-TM5639
46	C5	Feed-through, 4700 μ μ F, 500 V d.c.	75-TM5639
47	C6	Paper, 0.001 μ F \pm 20%, 600 V d.c.	74-TM5639
48	C7	Paper, 0.001 μ F \pm 20%, 600 V d.c.	74-TM5639
49	C8	Variable, 10–400 μ μ F, Special.	7-TM5639
50	C9	Feed-through, 4700 μ μ F, 500 V d.c.	75-TM5639
51	C11	Variable, 7.5–110 μ μ F, Special.	8-TM5639
52	C12	Electrolytic, 32 μ F, 35 V d.c.	72-TM5639
53	C13	Electrolytic, 10 μ F, 6 V d.c.	73-TM5639

<i>SOS Item No.</i>	<i>Circuit Ref.</i>	<i>Description</i>	<i>Works Ref.</i>		
SEMI-CONDUCTORS					
54	MR1)	S.T.C. Type C2D, Selenium Rectifier.	13-TM5642		
55	MR2)				
56	MR3			B.T.H. Type CS2A, Silicon Diode.	43-TM5639
57	MR4			B.T.H. Type CS2A, Silicon Diode.	43-TM5639
58	MR5			B.T.H. Type CS2A, Silicon Diode.	43-TM5639
59	MR6	B.T.H. Type CS2A, Silicon Diode.	43-TM5639		
VALVES, VALVEHOLDERS AND RETAINERS					
60	V1	OA2, Voltage Stabilizer.	45-TF1245		
61		Holder for V1, B7G, with skirt.	11-TM5642		
62		Screening Can for V1.	PC17501/2		
63	V2	85A2, Voltage Stabilizer.	46-TF1245		
64		Holder for V2, B7G, with skirt.	11-TM5642		
65		Screening Can for V2.	PC17501/3		
66	V3	12AU7, Double Triode.	47-TF1245		
67		Holder for V3, B9A, with skirt.	12-TM5642		
68		Screening Can for V3.	PC17502/2		
69	V4	EA52, Diode.	82-TM5639		
70		Retainer for V4.	17-TM5639		
71		Mounting Bracket for V4.	18-TM5639		
72		Anode Contact Spring for V4.	13-TM5639		
SWITCHES AND KNOBS					
73	SA	Toggle, 2-pole, ON/OFF.	TB23903/2		
74	SB	Rotary, 2-pole, 10-position, 2-wafer.	TM5643		
75	SC	Rotary, 2-pole, 4-position, 2-wafer.	TM5644		
76		Knob for SB or SC.	TB17848/3		
TRANSFORMERS					
77	T1	Mains Transformer.	TM5149/33		
78	T2	L.T. Transductor.	TM5645		
79	T3	Heater Isolation Transformer.	TM4818/3		
METERS					
80	M1	Moving-Coil Panel Meter, 100 μ A f.s.d., 500 Ω .	TM3970/74		
81	M2	Moving-Coil Panel Meter, 100 μ A f.s.d., 500 Ω .	TM3970/75		

<i>SOS Item No.</i>	<i>Circuit Ref.</i>	<i>Description</i>	<i>Works Ref.</i>
PILOT LAMP AND HOLDER			
82	PLP1	Tubular, 6·3-volt, 0·15-amp, M.B.C.	36-TF1245
83		Holder for PLP1, M.B.C.	TB25073/2
FUSES AND HOLDERS			
84	FS1	1-amp. (or 2-amp.) Glass Cartridge.	51-TF1245
85		Holder for FS1.	TB24330/1
86	FS2	150-mA, Glass Cartridge.	52-TF1245
87		Holder for FS2.	TB24330/1
PLUGS AND CONNECTING LEADS			
88	PL1	Mains Plug, 3-pin, 5-amp.	1-TM2560/AU
89		Mains Lead, 3-core, 6 ft. long, including Item 88.	TM2560/AU
90		Coaxial Connecting Lead.	TM5725
91		BNC Plug, included in Item 90.	2-TM5725
92	LKA	Link, for connecting HI I and HI II terminals.	TB28343
MISCELLANEOUS			
93		Dial Blank, for main tuning capacitor.	TB28130
94		Knob, for main capacitor dial.	TB17848/11
95		Dial Blank, for incremental tuning capacitor.	TB28131
96		Knob, for incremental capacitor dial.	TB23920/21
97		Cursor, for tuning capacitor dials.	TB25273/1
98		Front Panel.	TD21824
99		Meter Panel.	TD21827
100		Case Top Panel.	27-TF1245
101		Case Back Panel.	TE27392
102		Case Bottom Panel.	TD27395/1
103		Screw, 4 BA Special, for attaching Items 100, 101 and 102.	TA4008/4
104		Case Side Panel (left- or right-hand)	TD27383A
105		Handle (left or right side panel).	TB27473
106		Screw, $\frac{1}{4}$ -in. B.S.F., Phillips-head, for attaching side panels.	33-TF1245
107		Clips (set of two), for mains lead stowage.	23-TF1245
108		Dust Cover, for tuning capacitor, located behind terminals.	40-TF1245
109		Terminal, large, for l.f. test circuit.	TB27500
110		Terminal, small, for h.f. test circuit.	TB27499
111		Hand Screw, 2 BA Special, for attaching inductor support platform.	TB24900/4
112		Inductor Support Platform.	TC28850

<i>SOS Item No.</i>	<i>Circuit Ref.</i>	<i>Description</i>	<i>Works Ref.</i>
113		Tie Bolt, for bonding oscillator to TF1245.	TB28691
114		2 BA Hexagonal Wrench.	55B-TF1245
115		Operating and Maintenance Handbook.	OM1245

OPTIONAL ACCESSORIES

116		1- to 40-kc/s Matching Transformer.	TM5728A
117		Series Loss Test Jig.	TJ230
118		Dielectric Loss Test Jig (Inch Calibration).	TJ155B/1
119		Dielectric Loss Test Jig (Metric Calibration).	TJ155C/1

INDUCTORS FOR L.F. TEST CIRCUIT, TM1438 (SERIES)

120		0.2 μ H Inductor.	TM1438A
121		1.0 μ H Inductor.	TM1438B
122		1.5 μ H Inductor.	TM1438P
123		2.5 μ H Inductor.	TM1438C
124		5.0 μ H Inductor.	TM1438D
125		10 μ H Inductor.	TM1438E
126		25 μ H Inductor.	TM1438F
127		50 μ H Inductor.	TM1438G
128		75 μ H Inductor.	TM1438R
129		100 μ H Inductor.	TM1438H
130		200 μ H Inductor.	TM1438Q
131		250 μ H Inductor.	TM1438I
132		500 μ H Inductor.	TM1438J
133		1.0 mH Inductor.	TM1438K
134		2.5 mH Inductor.	TM1438L
135		5.0 mH Inductor.	TM1438M
136		10 mH Inductor.	TM1438N
137		25 mH Inductor.	TM1438O
138		Set of 18 Inductors, Items 120 to 138, in hardwood case.	TM4520

INDUCTORS FOR H.F. TEST CIRCUIT, TM4947 (SERIES)

139		2.5 μ H Inductor.	TM4947/1
140		0.5 μ H Inductor.	TM4947/2
141		0.05 μ H Inductor.	TM4947/3



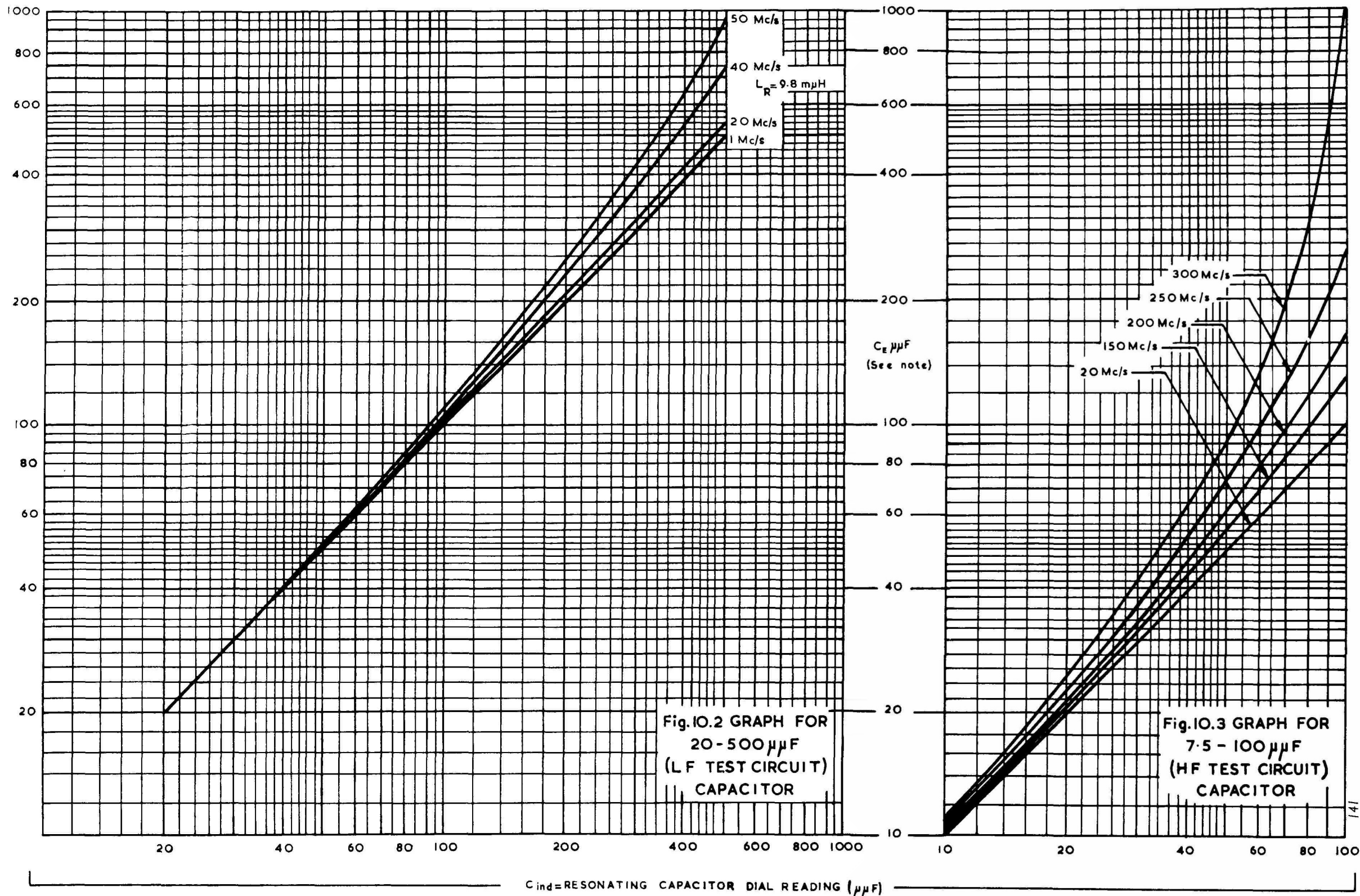

Fig. 10.2 GRAPH FOR
20-500 μμF
(L.F. TEST CIRCUIT)
CAPACITOR

Fig. 10.3 GRAPH FOR
7.5-100 μμF
(H.F. TEST CIRCUIT)
CAPACITOR

NOTE :
C_E = The effective value of resonating
capacitance at any frequency

$$= \frac{C_{ind}}{1 - \omega^2 L_R C_{ind}}$$

For the L.F. Test Circuit
L_R = 9.8 mμH between Inductance HI
and Capacitance E; and 2 mμH
between Capacitance HI and E.

For the H.F. Test Circuit
L_R = 2.8 mμH

INDICATED AGAINST EFFECTIVE
RESONATING CAPACITANCE

Figs. 10.2 and 10.3

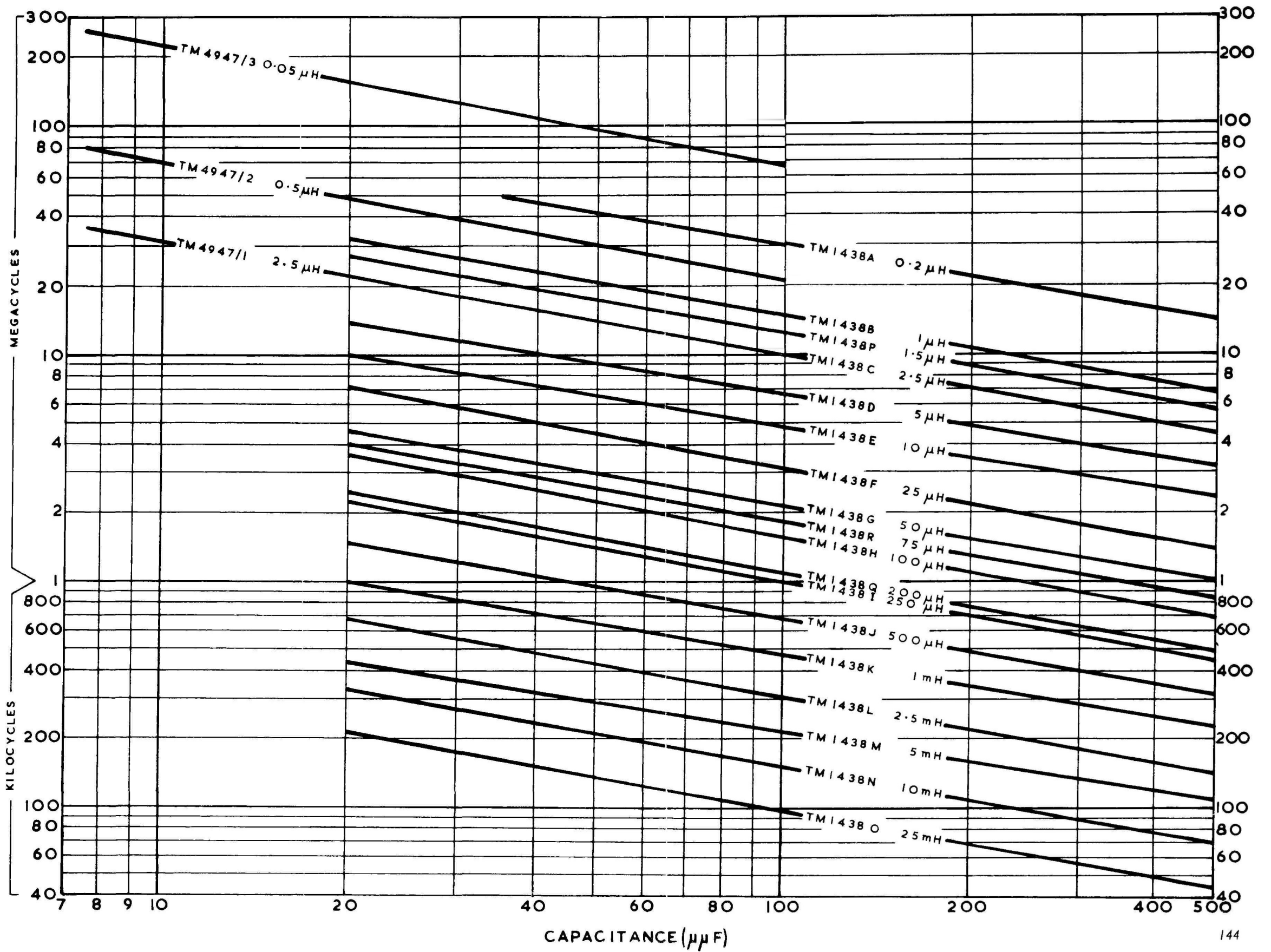

FREQUENCY AGAINST
 RESONATING CAPACITANCE
 FOR INDUCTORS, TYPE TM 1438 (SERIES) AND TM 4947 (SERIES).

Fig. 10.1

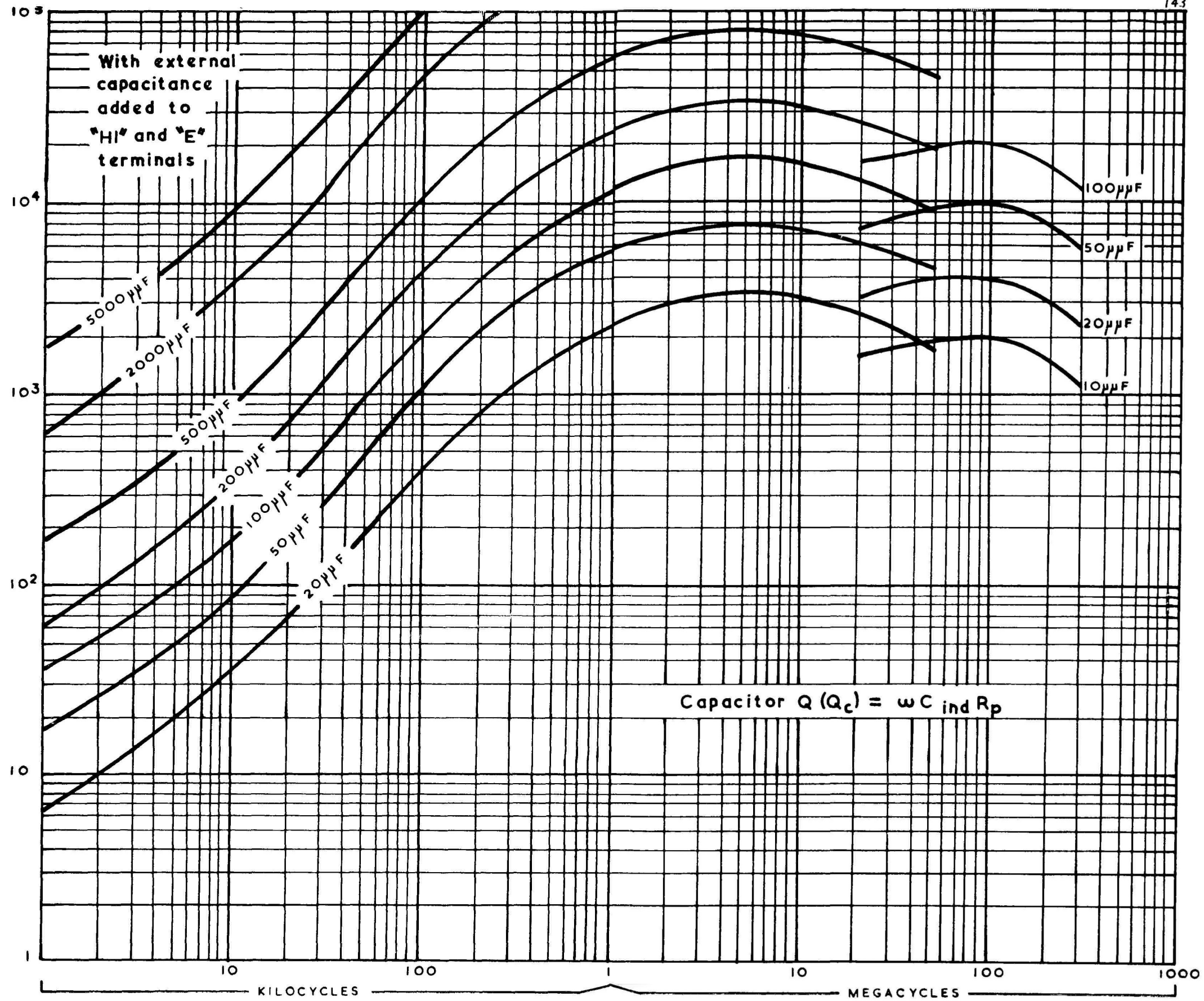

RESONATING CAPACITOR Q
AGAINST FREQUENCY

Fig. 10.4

CIRCUIT NOTES

* These components are selected during test as follows:

1. If necessary capacitor C14 is incorporated to level the response of the 1 kc/s—50 Mc/s test circuit at 50 Mc/s.
2. If necessary capacitor C15 is incorporated to increase the accuracy of readings at 200 Mc/s.
3. If necessary resistor R31 is incorporated across the primary of transformer T3, or in parallel with the heaters of valve V3, to adjust the heater voltage of V3 as required.

Resistors R19 and R20 may, if necessary for the calibration of meter M1, have resistors added in parallel with them.

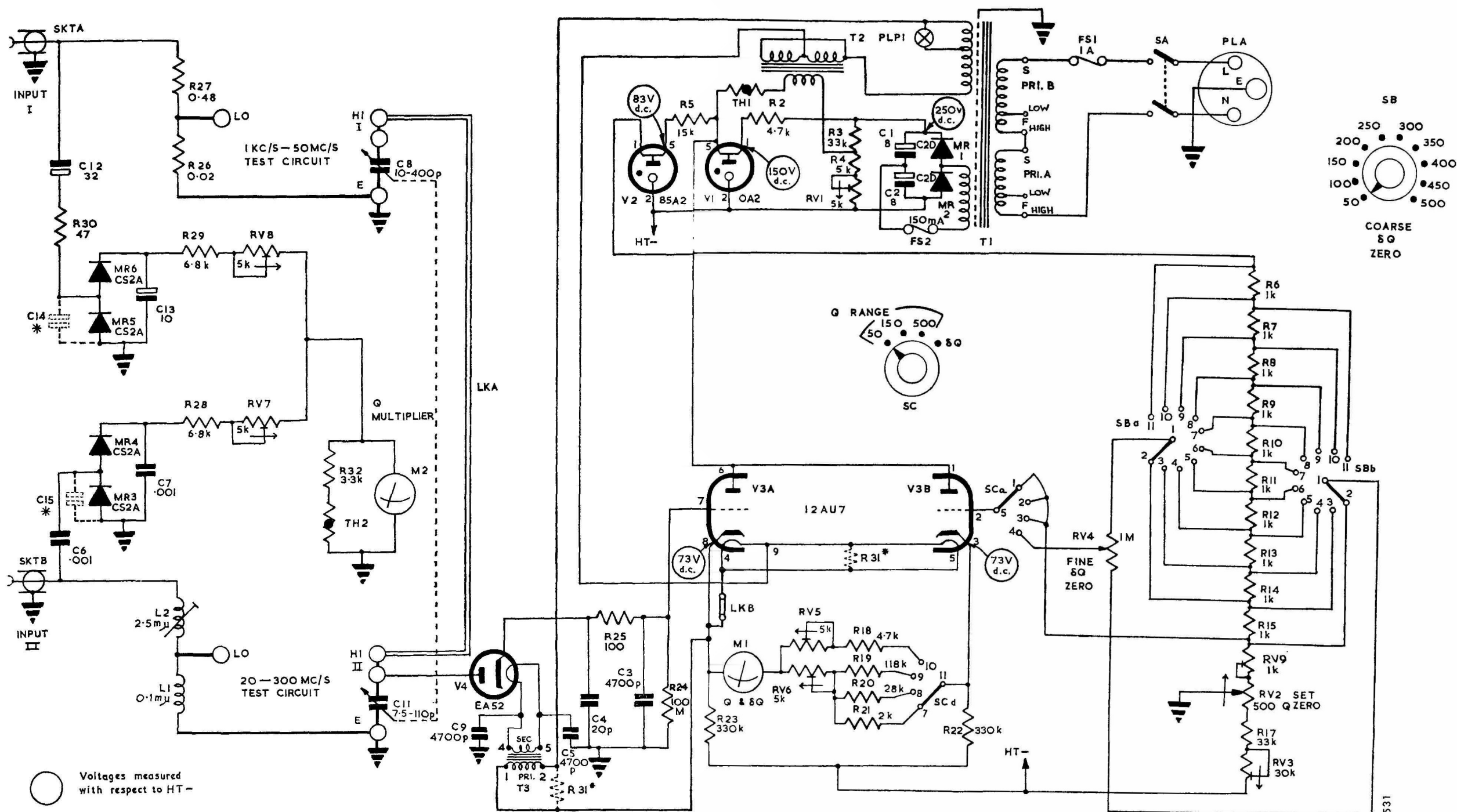

NOTES

1. COMPONENT VALUES

Resistors: No suffix=ohms, k=kilohms, M=megohms.
Capacitors: No suffix=microfarads, p=picofarads.

This Page Intentionally Blank

**MARCONI INSTRUMENTS LIMITED
ST. ALBANS, HERTS., ENGLAND**

SERVICE DIVISION

HEDLEY ROAD, ST. ALBANS, HERTS.

*Telephone: St. Albans 50731
(Ansafone)*

**HOME and EXPORT
SALES OFFICES**

LONGACRES, ST. ALBANS, HERTS.

*Telephone: St. Albans 59292
Telegrams: Measurtest, St. Albans
Telex: 23350*

U.S.A.

**MARCONI INSTRUMENTS DIVISION
OF ENGLISH ELECTRIC CORP.,
111 CEDAR LANE, ENGLEWOOD,
NEW JERSEY 07631**

Telephone: 201 567-0607

**BUNDESREPUBLIK
DEUTSCHLAND**

**MARCONI MESSTECHNIK GMBH,
8 MÜNCHEN-SOLLN,
WOLFRATSHAUSER STRASSE 243**

*Telefon: 79 78 50
Fernschreiber: 05 24642*

FRANCE

**MARCONI INSTRUMENTS,
SUCCURSALE DE FRANCE,
40 RUE DE L'AQUEDUC, PARIS Xe**

Téléphone: Paris 607 71-12 71-13

WORLD-WIDE REPRESENTATION