

TRANSMITTER-RECEIVER, RADIO, A40TECHNICAL HANDBOOK - FIELD AND BASE REPAIRSErrata

Note: This Page 0, Issue 3, supersedes Page 0, Issue 2, dated 15 Mar 62, and will be filed immediately in front of Page 1, Issue 1, dated 8 Jan 60. Para 1 to 5, Issue 2, are re-issued, Para 6 is a new instruction.

1. The following amendments will be made to the regulation.
2. Page 1,
 - (a) Title,

Delete: 'WIRELESS SET A40'

Insert: 'TRANSMITTER-RECEIVER, RADIO, A40'
 - (b) Para 1, line 1,

Delete: 'Wireless set'

Insert: 'Transmitter-receiver, radio, A40'
3. Page 6, Table 2, item 4,

Delete: 'SKTF-2 to 4'

Insert: 'SKTF-1 to 4'
4. Page 14,
 - (a) Para 43, after 'NORMAL',

Delete: 'and 25mV on WHISPER'
 - (b) Para 44(c), line 1, after '42(c)',

Delete: 'and (d)'
5. Page 1001, at foot of page, beneath Fig 4001,

Delete: 'Page 4001'

Insert: 'Page 1001'
6. Page 8, para 21,

Delete: 'all detail'

Insert: 'These voltages will be obtained from the Power supply set for bench testing manpack radio sets (Z4/6625-99-949-5448). The H.T. markings on the Control-monitor panel do not refer to similar markings on the A40 battery nor to references in para 8 Tels F462 Part 1.'

CONDITIONS OF RELEASE

(Applicable to copies supplied with War Office approval to Commonwealth and Foreign Governments)

1. This document contains classified UK information.
2. This information is disclosed only for official use by the recipient Government and (if so agreed by HM Government) such of its contractors, under seal of secrecy, as may be engaged on a defence project. Disclosure or release to any other Government, national of another country, any unauthorized person, the Press, or in any other way would be a breach of the conditions under which the document is issued.
3. This information will be safeguarded under rules designed to give the same standard of security as those maintained by HM Government in the UK.

~~WIRELESS SET A40~~

TRANSMITTER-RECEIVER, RADIO A40
TECHNICAL HANDBOOK - FIELD AND BASE REPAIRS

This EMER must be read in conjunction with Tels F 462 Part 2 which contains figures and tables to which reference is made

INTRODUCTION

1. The construction of the ^{TRANSMITTER RECEIVER RADIO A40}~~Wireless set A40~~ is such that field and base repairs will normally fall into two categories:-

- (a) Complete wireless sets
- (b) Sub-units returned as suspected faulty items from a more forward repair line.

2. This regulation will deal mainly with complete sets. Additional pages will be issued to cover the repair of sub-units as individual items at a later date.

DISMANTLING, REPAIR AND REPLACEMENT

(See Fig 2 of Tels F 462 Part 1 for a diagrammatic view of the assembly of set)

Plug-in units

3. To replace plug-in units:-

- (a) Remove the set from its case (four Allen-headed nuts and bolts)
- (b) Remove securing plate and polythene cover from units
- (c) Lever the unit gently from the base. (Ensure that no h.t. or l.t. voltages are on the unit).

4. The most usual mechanical fault in a plug-in unit is bent pins. Fig 4001 gives manufacturing details for a tool which can be used for replacing the pins individually or as a set.

Front panel components

5. To remove the front panel assembly:-
 - (a) Switch to channel 4.
 - (b) Remove the four No 6 BA screws securing trimmer shield to front panel.
 - (c) Slide the unit gently upwards and remove the aerial feed SKTD.
6. To replace the transformer unit, on-off switch wafer SB or headset socket (SKTU) refer to Fig 1 and Tels F 462 2001b, 2002, 2003 and proceed as follows. Unsolder R50 and the leads to the transformer unit from SB wafer (If SKTU only is to be changed it may be sufficient to release R50 and green fly lead).
7. To replace transformer unit or SKTU:-
 - (a) Remove the two units complete by releasing the four No 6 BA screws holding SKTU to the front panel.
 - (b) Remove the four wire retainers securing the transformer unit to the socket and separate sufficiently to unsolder the interconnections.
 - (c) Replace the faulty item.
8. To remove the switch wafer:-
 - (a) Proceed as in para 6.
 - (b) Release the two No 6 BA screws securing the switch wafer to the combined SA and SB 'click' plate.
 - (c) Remove and replace in reverse order (Fig 1 shows SB in OFF position).

Valve deck components (Tels F 462, Figs 2005, 2001)

9. Remove the four No 6 BA screws securing the trimmer assembly to the valve deck and pull the units apart.
10. Great care is necessary when replacing components on this unit because of the moulded polystyrene construction. Points to note are:-
 - (a) Components should be snipped out where possible using sharp cutters. This applies particularly where the individual valve sockets (single pins) are to be changed.
 - (b) Use heat shunts and/or wiring jigs when soldering.
 - (c) Do not disturb the layout of components or wiring (it is very easy to cause short-circuits).

Trimmer deck components (Tels F 462, Fig 2004)

11. To replace components:-

(a) Remove the clip of crystals.

(b) Remove the eight No 8 BA screws to separate the deck from the shield.

12. Coils and switch wafers can now be replaced by withdrawing the bakelite switch spindle. As in the valve deck care must be taken when using heat because of the polystyrene moulding.

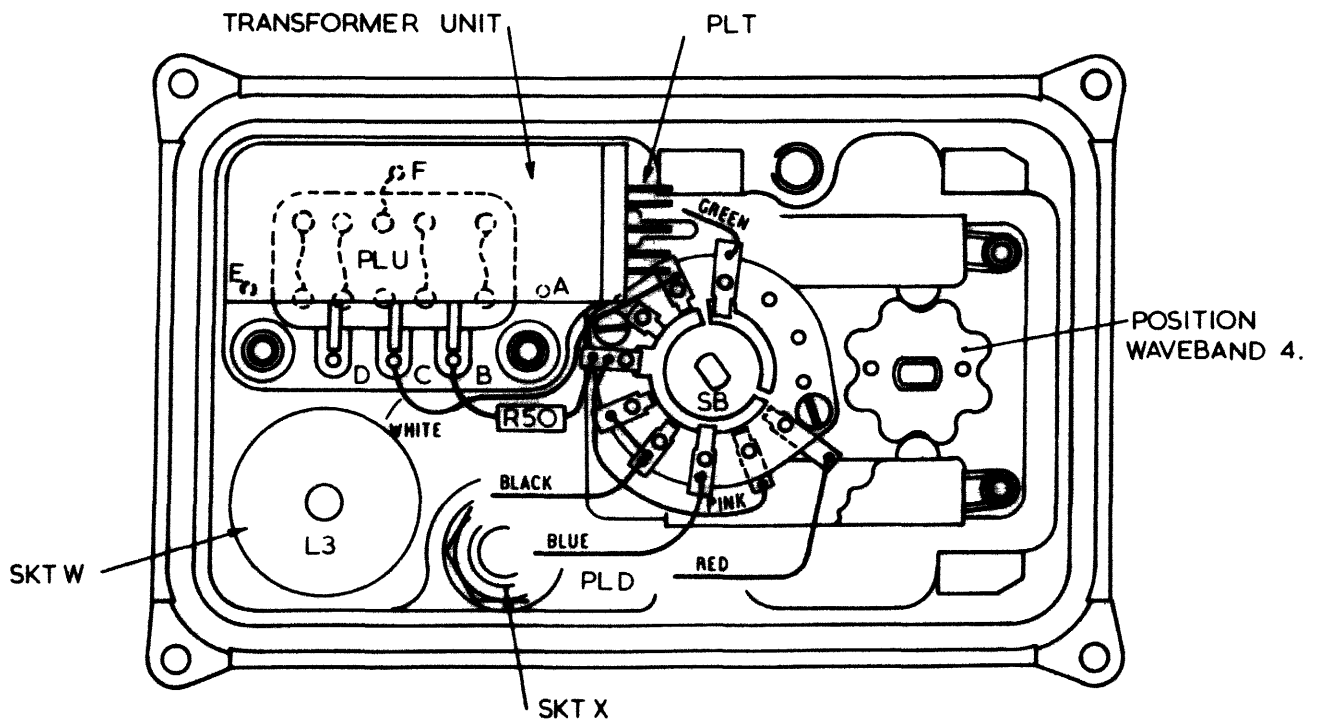

T F 464
1-1

Fig 1 - Front panel wiring

Preferred instrument	Suitable alternative
Signal generator No 18	Signal generator No 13
Signal generator No 12	Signal generator No 1, Mk 3 (for c.w. tests only)
Voltmeter, valve, No 3	Instrument, testing, electronic, multirange, No 1
Wattmeter, absorption, a.f., No 1	Meter, output power, No 3, Mk 1
Wattmeter, absorption, h.f., No 2	
Test set, deviation, f.m., No 2	
Signal generator, video frequency, No 1	Oscillator, b.f., No 5 or No 8
Frequency meter, r.f., portable, No 1 (to be developed)	Frequency meter, SCR 211
Multirange test meter, 1000Ω/V	Instrument, testing, Avometer, universal, 50-range
A.C. p.s.u. for manpack wireless sets (under development)	Power pack for W.S. 31 (modified) - see Tels F 364
Kits, testing, vehicle and manpack wireless sets (Tels M 152)	
Apparatus, seal testing (Tels M 631)	
Ovens, drying, telecommunications (Tels M 601)	

Table 1 - Test equipment schedule, field and base repairs

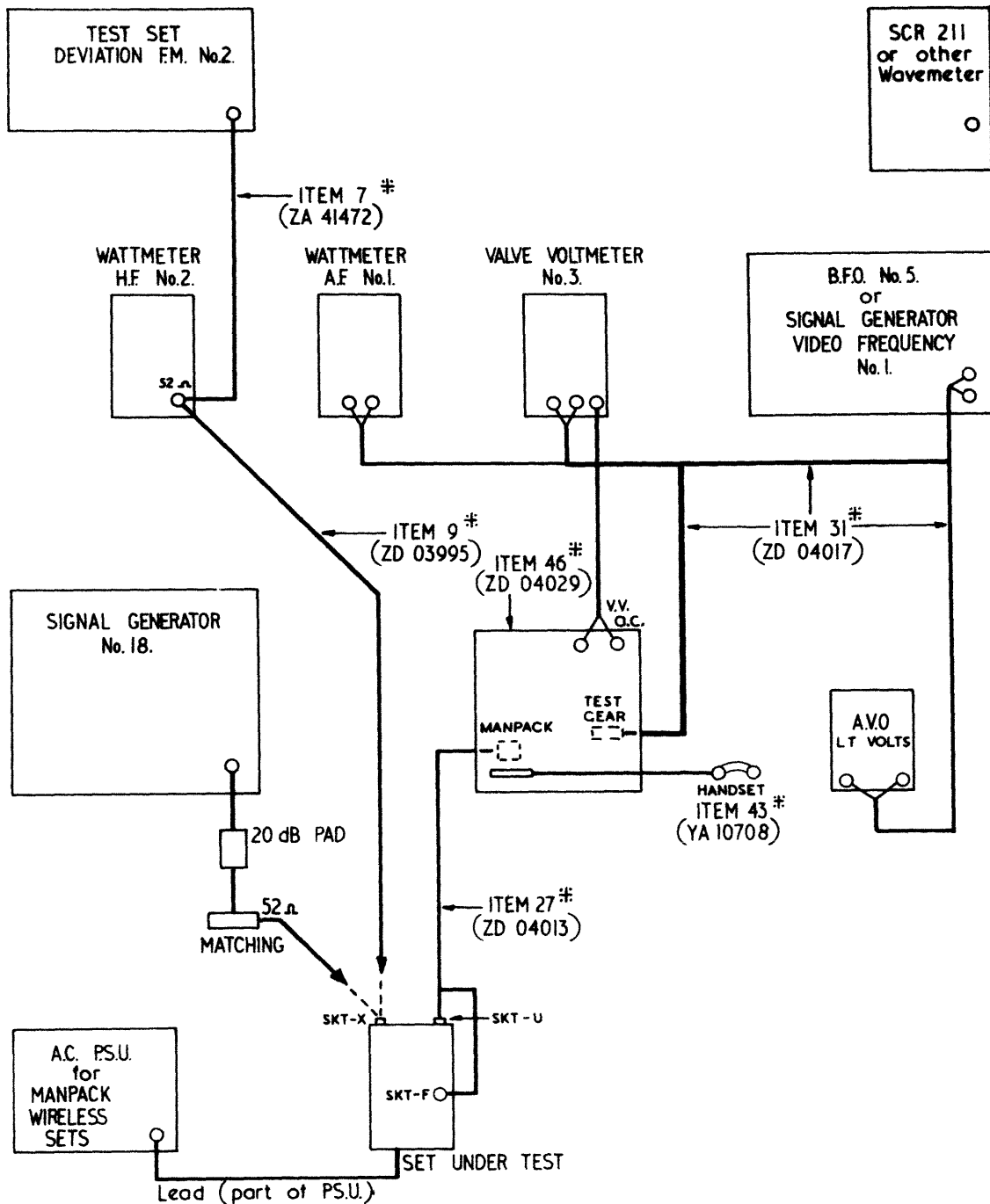

‡ FOR FULL DESIGNATION SEE TABLE 1001, TELS M 152

T F 464
1-2

Fig 2 - Test equipment layout using Kits, testing, vehicle and manpack wireless sets

Connector box SC or Fig 3 SC Position	A40 test point (Tels F 462 Fig 2001a and b)	Reading
MANPACK 1	TP1	A.F. discriminator output
MANPACK 2	SKTF - 3 to chassis	Limiter grid current
MANPACK 3	SKTF - 4 to chassis	Modulator bias (V2 grid current)
MANPACK 4	SKTF - 2 to 4	A.F.C. discriminator output
MANPACK 5	SKTF - 7 to chassis	A.F.C. drive (V12 grid current)
MANPACK 6	SKTF - 6 to chassis	P.A. screen volts (used to align p.a. on CPRC 26)
MANPACK 7	SKTF - 5 to chassis	H.T. (90V)

Table 2 - VALVE VOLTMETER switch connections (see Fig 3 or Tels M 152 Fig 2017)

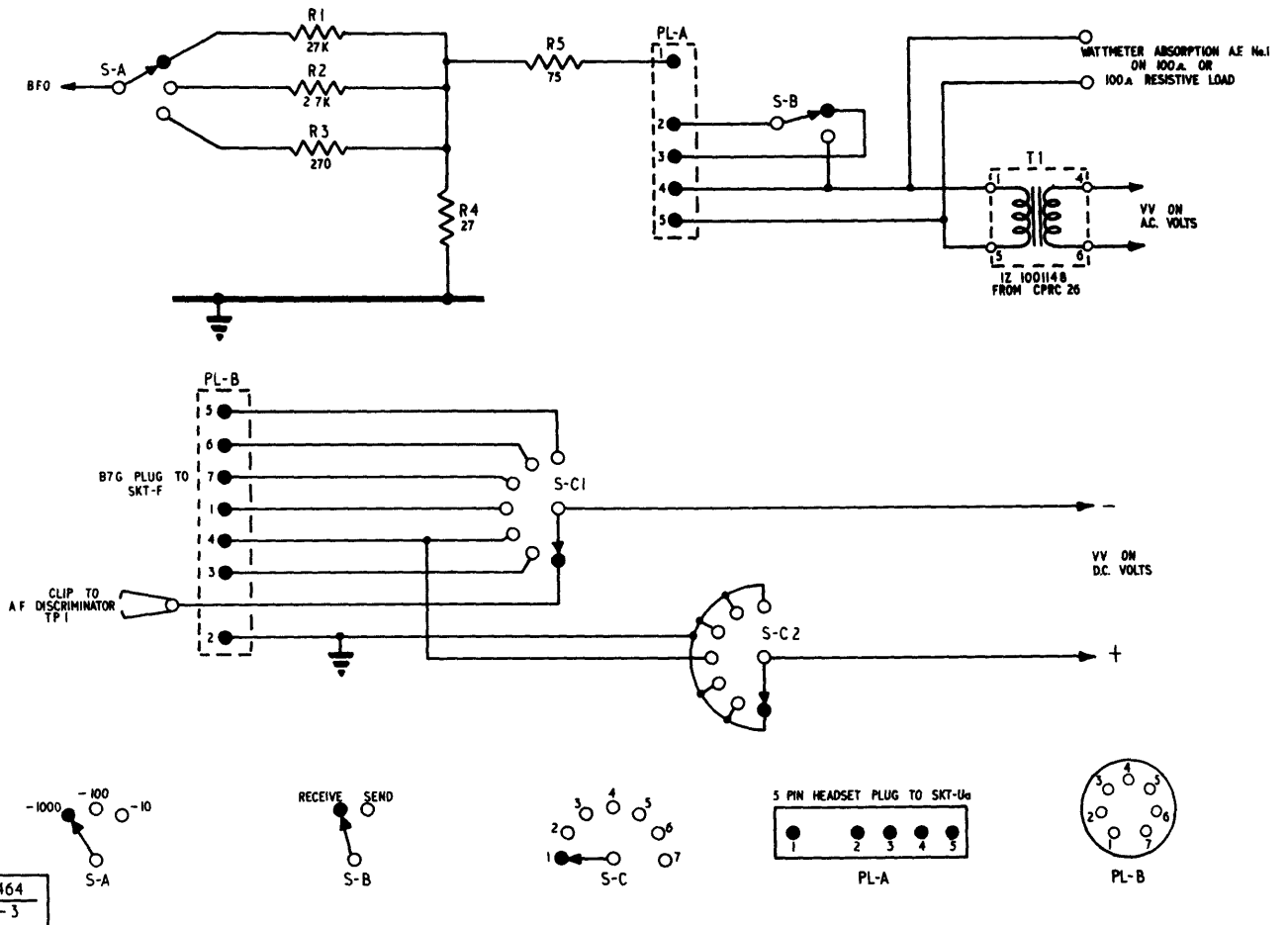

Fig 3 - Circuit diagram of interconnections in lieu of connector box

SPECIFICATION TESTS

13. These tests are divided into two categories class A and class B.

Class A tests

14. These tests are those necessary to ensure correct operation of the set and should be carried out in full on initial inspections and after extensive repairs or overhauls. It should not however be necessary to completely check the set after plug in unit changes. Suggested sections to be carried out after changes of these units are to be found in Table 4.

Class B tests

15. These tests need not be carried out after every overhaul but are included since they may assist in locating obscure faults.

Test conditions

16. Table 1 gives the list of preferred test equipment. Tests are described in the text assuming that Kits, testing, vehicle and manpack wireless sets are available. The main part of this kit is Connection boxes, vehicle and manpack wireless stations (ZD 04022), referred to in the text as the connector box. If this is not available Fig 3 gives an alternative test box which can be built up locally. This gives the correct input and output impedances and connections to the test socket. Table 2 relates the switch positions to A40 test points (See also Tels F 462 Table 2016).

A.F. impedances

17. The a.f. output shall be measured into a 100Ω resistive load. The modulation inputs quoted are the open circuit volts on an a.f. generator with an effective output impedance of 100Ω. (The MP 'Z' switch on the connector box caters for this).

Signal generator output

18. Where an input voltage to the set is quoted this is the open circuit voltage at the terminating unit.

Control switch

19. This shall be at NORMAL unless otherwise stated.

Supply voltages

20. 'Normal' volts shall be

PLV pin 3	1.25V
PLV pin 4	45V
PLV pin 2	90V
PLV pin 1	-2.5V

'Low' volts shall be

PLV pin 3	1.05V
PLV pin 4	34V
PLV pin 2	68V
PLV pin 1	-2.5V

21. These will normally be obtained from the bench power pack for manpack sets. If this is not available the power pack described in Tels F 364 modified by the addition of a 2kΩ resistor in series with a 5kΩ potentiometer connected between the H.T.2 terminal and H.T.- (Fig 1002 of Tels F 364 refers). If the voltage at H.T.1 is set to +90V then the slider of the 5kΩ potentiometer can be set to give +45V.

GENERAL TESTS

Power consumption

22.

	Volts	1.25V	45V	90V
Receive	Max Drain	600mA	15.5mA	3.5mA
Send	Max Drain	975mA	10mA	37mA

Channel alignment

23. Before commencing specification tests the alignment of the channel frequencies should be checked as follows:-

- (a) Connect the set to the test gear as in Fig 2 using the connector box.
- (b) Set SYSTEM SWITCH at MANPACK R and VALVE VOLTMETER to position 2 (limiter grid).
- (c) Switch set to Channel 1.
- (d) Adjust R.F. channel 1 trimmer for maximum limiter grid current on the v.v. The correct setting is the first response obtained commencing from a fully anticlockwise position. (If necessary inject a signal at channel frequency).
- (e) Adjust power supplies to the set under test to low volts condition and connect Wattmeter, absorption, h.f. No 2 to SKTX.
- (f) Switch VALVE VOLTMETER to position 4 (a.f.c. discriminator output) and SYSTEM SWITCH to MANPACK S.
- (g) Adjust M.O. channel 1 trimmer for zero $\pm 0.1V$ d.c. output on the v.v. The correct setting is the first response obtained commencing from a fully anticlockwise position.
- (h) Readjust power supplies to normal volts.
- (j) With the Wattmeter, h.f. No 2 connected to the remote aerial socket SKTX adjust P.A. trimmer for maximum power output.
- (k) Repeat the procedure in sub para (c) to (j) on channels 2 to 6.

RECEIVER TESTS

Selectivity

Specification

24. Total bandwidth: at -6dB 65 to 85kc/s
at -60dB not greater than 250kc/s
Centre frequency: 4.3Mc/s \pm 5kc/s

Method

25. (a) Connect Signal generator No 18 via 20dB attenuator pad and 52 Ω matching and termination unit to SKTX (remote aerial socket of the wireless set).
- (b) Connect the test equipment to the set via the connector box as in Fig 2.
- (c) Switch VALVE VOLTMETER on test box to position 2 (limiter grid volts).
- (d) Inject 20 μ V (200 μ V on sig gen) c.w. at highest channel frequency (normally channel 6).
- (e) Adjust the signal generator frequency until the i.f. output from the set is 4.3Mc/s \pm 500c/s as measured on the frequency meter loosely coupled to the limiter grid. (A convenient point is the +ve v.v. terminal).
- (f) Reduce input to 2 μ V (20 μ V on sig gen) and note the limiter grid current with this input.
- (g) Increase the signal generator output by 6dB (ie 4 μ V into set).
- (h) Adjust the frequency of the signal generator above and below the frequency at (d) above to give the same limiter grid current as in (f). Measure the intermediate frequencies obtained at these points.
- (j) (i) The difference between the two frequencies in (h) shall be between 65 and 85kc/s.
- (ii) The mean of the two frequencies shall be 4.3Mc/s \pm 5kc/s.
- (k) Increase the signal generator output by 60dB (ie to give set input of 2mV) and repeat (h).
- (l) The difference between the two frequencies shall not exceed 250kc/s.

Receiver frequency error

Specification

26. \pm 7kc/s of nominal channel frequency.

Method

27. (a) Inject a $10\mu\text{V}$ c.w. signal into the set with connections as for selectivity checks.
- (b) Switch set to channel 1.
- (c) Switch VALVE VOLTMETER switch to position 1 (a.f. discriminator output).
- (d) Adjust the signal generator to give zero reading on valve voltmeter.
- (e) Measure the signal generator frequency. This shall be within $\pm 7\text{kc/s}$ of the nominal frequency for channel 1 (Tels F 462 Table 2014).
- (f) Repeat for all channels.

28. An alternative method is to loosely couple the frequency meter, of SCR211, into the set and adjust for zero a.f. discriminator output as above. It is necessary to use the third harmonic of the highest calibrated range of the SCR211 but normally there is sufficient output for this test at the A40 frequencies.

Sensitivity

Specification

29. (a) Normal volts: $2\mu\text{V} \pm 15\text{kc/s}$ deviation at 1kc/s to give ratio $\frac{\text{Signal} + \text{Noise}}{\text{Noise}}$ of at least 20dB
- (b) Low volts: $4\mu\text{V} \pm 15\text{kc/s}$ deviation at 1kc/s to give ratio $\frac{\text{Signal} + \text{Noise}}{\text{Noise}}$ of at least 20dB

Method

30. (a) Connect the test equipment via the connector box as for previous checks (Fig 2) but disconnect the wander lead to T.P.1 (a.f. discriminator output).
- (b) Set HANDSETS switch on the connector box to SIG NOISE. The set output is then connected across 100Ω and stepped up by a transformer to give an a.c. voltage of measurable amplitude.
- (c) Connect the a.c. probe of the valve voltmeter to the V.V. A.C. terminals on the back of the connector box and set the v.v. to the 5V a.c. range.
- *(d) Inject, from the signal generator, a set input signal of $2\mu\text{V}$ channel 1 r.f. deviated $\pm 15\text{kc/s}$ at 1kc/s modulation frequency.
- *(e) Adjust the signal generator frequency to give maximum a.c. voltage on the v.v. Note this reading.
- (f) Switch modulation off and again note the reading.

- (g) The ratio of the readings in (e) to (f) shall exceed 10:1 (ie 20dB).
- (h) Repeat on channels 2-6 at normal volts.
- (j) Repeat on all channels at low volts but with a set input of $4\mu\text{V}$.

*Note: An alternative is to tune the signal generator on c.w. for maximum quieting, ie minimum reading on valve voltmeter.

Limiting characteristic

Specification

31. Not greater than 3dB change in output for change in input from $5\mu\text{V}$ to 1mV.

Method

- 32. (a) Connect the test equipment as in Fig 2 and switch HANDSETS to OFF.
- (b) Switch set to any convenient channel.
- (c) With input to the set of $5\mu\text{V}$ modulated 15kc/s deviation, note the a.f. output.
- (d) Gradually increase the input to 1mV, noting the a.f. output. The a.f. output shall not vary by more than 3dB from the reading at (c).

A.F. power output

Specification

33. NORMAL: Not less than 3mW into 100Ω for 1mV input deviated $\pm 15\text{kc/s}$ at 1kc/s.
WHISPER: -15dB $\pm 3\text{dB}$ of NORMAL

Method

- 34. (a) Inject a signal of 1mV modulated by 1kc/s to $\pm 15\text{kc/s}$ deviation as in para 32(d). Set VALVE VOLTMETER switch to WANDER. Note the a.f. wattmeter reading. This shall not be less than 3mW.
- (b) Switch the set to WHISPER. The output shall fall by 15dB $\pm 3\text{dB}$ of the reading obtained in (a).

TRANSMITTER TESTS

R.F. power output

Specification

35. Normal volts: Not less than 275mW
Low volts: Not less than 100mW

Method

36. (a) Connect the equipment to the connector box as in Fig 2.
- (b) Connect the remote aerial socket to the Wattmeter, absorption, h.f., No 2 using the coaxial connector ZA 03995 which has a take off point for the deviation meter.
- (c) With the set on send the r.f. output on all channels shall be at least 275mW.
- (d) Adjust power supply to give low volts input. Check that the r.f. output on the highest and lowest frequency channels is at least 100mW.
- (e) Return supply volts to normal.
- (f) On any one channel check with the condition indicator that there is r.f. output at the rod aerial socket SKTW.
- (g) If the rod aerial loading coil L3 has been changed or is suspect check that, with a dummy load of 18pF in series with 50Ω connected between SKTW and chassis, a voltage of at least 3V is developed across the 50Ω resistor.

A.F.C. operation

Specification

37. An error of ±250kc/s to be corrected to within 7kc/s of original frequency by a.f.c.

Method

38. (a) Connect the equipment to the connector box as in Fig 2.
- (b) Set VALVE VOLTMETER switch to read a.f.c. discriminator output (position 4) and SYSTEM switch to MANPACK S.
- (c) Adjust the appropriate M.O. channel trimmer for zero a.f.c. output.
- (d) Couple the frequency meter to measure either the resultant intermediate frequency at pin 7 of the test socket or the output frequency at SKTW.
- (e) Short circuit the a.f.c. discriminator (pins 1 and 7).
If using signal frequency the 45V supply may be switched off.
- (f) Adjust frequency meter to 250kc/s above the frequency noted in (d).
- (g) Increase frequency by unscrewing M.O. trimmer until a beat is obtained with the frequency meter.
- (h) Remove the short circuit from the a.f.c. output, or switch on 45V.

- (j) Readjust the frequency meter for zero beat and note the frequency. This shall be within 7kc/s of the reading obtained in (d).
- (k) Repeat (e) to (j) for a decrease in frequency of 250kc/s.
- (l) Repeat for all channels.

Neutralising

Specification

39. Frequency shift with aerial short circuited to be less than 40kc/s.

Method

- 40. (a) Connect the condition indicator or, if available, the dummy load of 18pF and 50Ω across the rod aerial socket SKTW.
- (b) Loosely couple the frequency meter to measure the sender frequency.
- (c) Render a.f.c. inoperative by short-circuiting a.f.c. socket pins 1 and 7 or by switching off the 45V h.t.
- (d) Check the send frequency.
- (e) Insert a shorting plug into SKTX and check the sender frequency again.
- (f) The difference between frequencies in (d) and (e) shall not exceed 40kc/s.

Modulation sensitivity

Specification

41. NORMAL: 250mV to give deviation of 5 to 11kc/s.

WHISPER: 25mV to give deviation of 5 to 11kc/s.

Method

- 42. (a) Connect up as in Fig 2 and switch to any convenient channel. Set SYSTEM switch on the connector box to MANPACK S.
- (b) Set B.F.O. switch to WANDER and adjust the b.f.o. output to give 25V at 1kc/s (check, using the valve voltmeter a.c. probe if necessary).
- (c) With set control at NORMAL switch B.F.O. switch to $\dot{\div}100$ (reset b.f.o. to 25V if necessary) check that the deviation for this input lies between 5 and 11kc/s.
- (d) With set control at WHISPER and B.F.O. switch to $\dot{\div}1000$ check that deviation is within limits 5 to 11kc/s

Sidetone

Specification

43. 1mW minimum into 100 Ω with input of 250mV on NORMAL and 25mV on WHISPER

Method

44. (a) Connect as for modulation sensitivity tests (para 42).
- (b) Switch HANDSETS switch OFF and VALVE VOLTMETER switch to WANDER.
- (c) Check that with inputs as in para 42(c) and (d) the a.f. output into 100 Ω is not less than 1mW.

Modulation frequency characteristic (B test)

Specification

45. Deviation, obtained with an input of 250mV at 1kc/s with set at NORMAL, to be maintained with inputs of 150 to 350mV over frequency range 400c/s to 3kc/s.

Method

46. (a) Connect up as for modulation sensitivity tests (para 42) and set SYSTEM switch on connector box to MANPACK S.
- (b) With input of 250mV at 1kc/s ($25V \div 100$) and set control at NORMAL, check the deviation.
- (c) Swing the b.f.o. frequency from 400c/s to 3kc/s and adjust the b.f.o. voltage to maintain the deviation obtained in (b). The input required should always lie between 150mV and 350mV.

Frequency error

Specification

47. Nominal channel frequency ± 9 kc/s.

Method

48. (a) Loosely couple the output to the frequency meter.
- (b) Connect the set to the test equipment and set the SYSTEM switch on the connector box to MANPACK S.
- (c) Referring to Table 2014 (Tels F 462) check that each channel is within 9kc/s of the nominal frequency for the appropriate model (A or B).

SEAL TESTING

Specification

49. Initial pressure	10 lb/sq. in.
Pressure after 15 hours	6.3 lb/sq. in.
Time constant	35 hours
Leakage rate	20 cc/hr

Method

50. (a) Raise the internal pressure to 10 lb/sq. in.
- (b) After a suitable period check the fall in pressure. 6.3 lb/sq. in. after 15 hours is quoted but for alternative pressures at 35 hour rate see Tels M 631.
- (c) The set shall be dried using the Oven, drying, tels (Tels M 601) and a new desiccator fitted.

FAULT-FINDING AND REPAIR

51. The construction of the set does not facilitate fault diagnosis by the normal method; eg signal tracing stage-by-stage is very difficult, entailing the injection of a signal into a plug-in socket.
52. A large number of faults will be repairable by the replacement of plug-in unit stages (but note para 54). Table 3 gives a list of symptoms by which the faulty unit can be traced. This can often be achieved by using only the condition indicator (for r.f. output) and a headset. If, however, the set is connected to analytical test equipment and the test socket outputs are metered (as in Fig 2 or Fig 3 set-up) more precise diagnosis can be made.
53. The repair of a wireless set by plug-in unit substitution can be carried out by using a Functional tester No 2 (details in Tels F 463 when published). The tests using this instrument will normally consist of ensuring that the R.F., M.O. and P.A. trimmers are correctly adjusted (para 23 details the procedure). Where the sub-unit is replaced in workshops it is recommended that part of the specification tests to the set be carried out as listed in Table 4.
54. Plug-in units aligned in one wireless set are not normally directly interchangeable with those in other sets and generally further alignment will be required. Complete interchangeability can only be obtained with sub-units which have been aligned on specially designed jigs. These jigs will be described and separately specified in a later issue of additional pages to this regulation.
55. Sub-units are most likely to suffer from valve failure and Table 5 gives the test data when using the Tester, valve, Avo, No 3. Tests can also be made using the Functional test set No 2 or Canadian test set CTS3. (see Tels F 543). Following a valve check wiring and components should be inspected as in Figs 2007, 2015, in Tels F 462.

Receive condition	Send condition	Possible faulty unit
Dead	R.F. output but no sidetone	A.F. amplifier
Dead	Correct	Limiter or a.f. discriminator
Full noise level but no signals	Correct	R.F. amplifier
Full noise level but no signals	R.F. output but no sidetone	Crystal oscillator or mixer
Low noise level and weak or no signals	Correct	I.F. amplifiers 1 to 4 depending on noise level
Correct	No r.f. output or sidetone	M.O. valve or coil
Correct	No r.f. output but sidetone present	P.A. valve
Correct	R.F. output but no sidetone	A.F.C. driver or a.f.c. discriminator

Table 3 - Test for finding faulty unit

56. Points to note when working on plug-in units are:-

- (a) Snip wires where possible when changing components.
- (b) When replacing valves cut the leads first using the faulty valves as a sample and refit using the same layout.
- (c) When fitting a new CV 2254 in the mixer unit disconnect the metalising from pin 3 of the valve, to avoid shorting the oscillator output.
- (d) Do not attempt to replace coil bobbins, they are fixed to the chassis by Araldite.

Unit replaced	Specification tests	Relevant para
R.F. amplifier mixer	Sensitivity A.F. power output Transmitter frequency error	29 - 30 33 - 34 47 - 48
Crystal oscillator,	Sensitivity A.F. power output Transmitter frequency error Receiver frequency error	29 - 30 33 - 34 47 - 48 26 - 27
I.F. amplifiers	Sensitivity Selectivity A.F. power output	29 - 30 24 - 25 33 - 34
Limiter	Sensitivity A.F. power output	29 - 30 33 - 34
A.F. unit	A.F. power output	33 - 34
Modulator	R.F. power output Modulation sensitivity Transmitter frequency error	35 - 36 41 - 42 47 - 48
A.F.C. driver	Sensitivity A.F.C. operation Transmitter frequency error	29 - 30 37 - 33 47 - 48
M.O., P.A. valves	R.F. power output Transmitter frequency error	35 - 36 47 - 48

Table 4 - Specification tests after unit replacement

Valve or unit	Tester, valve, Avo, No 3 data							Valve being checked
	Selector switch	Vf	Grid V	Anode V	Screen V	App. Ia	App. mA/V	
M.O., P.A.	524332600	1.4	-25	200	150	19.5	1.8	CV 2240
I.F.	042603000	1.4	0	50	0	1.2	0.6	CV 2254
Limiter	042603000	1.4	0	50	0	1.2	0.6	CV 2254
A.F.	564430200	1.4	-2.5	50	50	3.0	0.6	CV 2238
Modulator	464300200	1.4	0	50	0	1.6	1.0	CV 2237
R.F.	004326500	1.4	0	50	50	4.0	1.4	CV 2237
Mixer	246003600	1.4	0	50	50	1.2	No reading	CV 2254
Crystal Osc.	534302600	1.4	0	50	90	3.0	0.2	CV 2237
A.F.C. driver	300406200	1.4	0	50	0	1.3	0.2	CV 2237

Table 5 - Test data for units using Tester, valve, Avo, No 3

Note: The next page is Page 1001

Note: These Pages 19-28, Issue 1 are to be filed immediately after Page 18, Issue 1, dated 8 Jan 60.

They contain additional information. Delete 'Note: The next page is Page 1001' at bottom of Page 18.

SPECIFICATION TESTS, TEST RIG, ELECTRONIC EQUIPMENT, TEST CONTROLLER METHOD

General

57. The tests described in this regulation use the Test Rig, Electronic Equipment, Test Controller No 1 or No 2. The operating instructions and technical description of this equipment are given in Tels M 382.

58. The tests detailed in this regulation are those that are essential to prove the serviceability of an equipment and shall be carried out each time an equipment is inspected or repaired.

59. No attempt should be made to reconcile this regulation with previous issues as it has been considerably amended in the light of experience and the use of modern instrumentation.

60. Fig 1002 shows the layout of the controls, sockets etc on the Test Controller. Reference to these items in the text is made by using the abbreviation for the relevant unit followed by the code number of the required control etc, eg CTC14 indicates Control Test Conditions unit, control code number 14.

61. The Test Controller shall be fitted with an Interface Larkspur (IF(L)) in the Interface, equipment under test position.

62. The following connectors (part of Cable Assembly Set, issued with the t.r.e.) are required to carry out the operations detailed in this regulation, they are referred to in the text by their item number, ie Connect CTC20 to SKTX using item 7.

- a. Item 7 Cable assy (6625-99-621-8729)
- b. Item 12 Cable assy (6625-99-621-8734)
- c. Item 23 Cable assy (6625-99-621-8745)
- d. Item 26 Cable assy (6625-99-621-8748)

Note: This connector detail is extracted from EMER Tels M 382, the same item numbers being retained to provide consistent cross-referencing.

Test conditions

63. The supply voltages for the radio set shall be as follows:

- a. NORMAL voltages shall be:
 - PLV pin 3 - 1.25V
 - PLV pin 4 - 45V
 - PLV pin 2 - 90V
 - PLV pin 1 - -2.5V
- b. LOW voltages shall be:
 - PLV pin 3 - 1.05V
 - PLV pin 4 - 34V
 - PLV pin 2 - 68V
 - PLV pin 1 - -2.5V

64. These voltages will be obtained from the Power supply set for bench testing manpack radio sets (Z4/6625-99-949-5448). The HT markings on the control-monitor panel do not refer to similar markings on the A40 battery, nor to references in Tels F 462 Part 1 para 8.

65. The standard a.f. load resistance shall be 100Ω, unless otherwise stated.

66. The modulation inputs quoted in this regulation are the open circuit volts from a 300Ω a.f. generator terminated to match into a 100Ω impedance (see Tels M 382).

67. The Test Rig Electronic (t.r.e.) will be fitted with one of two signal generators. They are the Signal generator CT562 or the Schlumberger FSD120S. On equipments fitted with the Signal generator CT562 care must be taken to ensure that the 6db attenuator (part of the s.g. CES) is fitted to the output socket of the s.g.

68. The s.g. shall be set to the nominal test frequency. No attempt shall be made to tune the s.g. to the radio set. All levels are quoted as attenuator setting in db with the s.g. output level maintained at 1V.

69. All r.f. and a.f. power measurements shall be made directly on the digital voltmeter in the t.r.e. All powers will be quoted in the text of this regulation as voltages with the corresponding power in brackets, ie r.f. power 4V (16W), a.f. power 700mV (10mW).

70. The law for r.f. power measurements is:

$$W = E^2 \quad \text{Where } E \text{ is the d.v.m. reading}$$

71. The law for a.f. power measurements is:

$$W = \frac{E^2}{R} \quad \text{Where } E \text{ is the d.v.m. reading and} \\ R \text{ is the a.f. load resistance}$$

72. The control switch on the radio set shall be at NORMAL unless otherwise stated.

73. Set t.r.e. controls for all tests unless otherwise stated:

CS6	Depressed (supply on for operation of t.r.e. circuitry and relays only)
CTC26	Int
IF(L)7	A40

General tests

Power consumption

74.

	Volts	1.25V	45V	90V
Receive	(Max drain)	600mA	15.5mA	3.5mA
Send	(Max drain)	975mA	10mA	37mA

Alignment of channel frequencies

75. Before commencing specification tests the alignment of the channel frequencies should be checked as follows:

- a. Connect IF(L)15 to SKTF using item 26, wander lead to TP1.
- b. Depress CTC6 and IF(L)8. Switch SB on radio set to NORMAL. Set d.v.m. to a suitable range (usually 18V range).
- c. Switch radio set to channel 1 and adjust RF channel 1 trimmer for a maximum reading on the d.v.m. The correct setting is the first response obtained starting from a fully anti-clockwise position. Note: If necessary inject a signal at channel frequency. To do this, connect CTC20 to SKTX using item 7. Set CTC1 to RX CW, depress CTC6 and IF(L)8. Set the s.g. to channel frequency (Tels F 462 Part 2 table 2014) attenuator approximately 96dB.
- d. Adjust the power supplies to the radio set to LOW volts. Connect CTC20 to SKTX using item 7. Set CTC1 to CW TX, depress CTC6 and IF(L)13.
- e. Adjust MO channel 1 trimmer for zero $\pm 0.1V$ on the d.v.m. The correct response is the first response obtained commencing from a fully anti-clockwise position.
- f. Re-adjust power supplies to NORMAL volts. Depress CTC7 and adjust PA trimmer channel 1 for max on the d.v.m. (18V range).
- g. Repeat c. to f. for channels 2-6.

Receiver tests

Selectivity

76. Specification:

Bandwidth at -6dB: 65 to 89kHz
at -60dB: not greater than 250kHz

Method:

- a. Connect CTC20 to SKTX using item 7; connect IF(L)16 to SKTU using item 23 and connect IF(L)15 to SKTF using item 26.
- b. Set t.r.e. controls:

CS1	Depressed	CTC6	Depressed
CTC1	RX CW	IF(L)8	Depressed
CTC2	QUIETING		
- c. Set s.g. to channel 6 frequency (Tels F 462 Part 2 Table 2014), attenuator level 114dB.
- d. Switch radio set to channel 6 and note the reading on the d.v.m. (1).

e. Increase the s.g. level by 6dB (108dB). Adjust the s.g. frequency below (f1) and above (f2) that of c. and note the frequencies at which the d.v.m. reads (1). The difference between f1 and f2 shall be between 65-85kHz and symmetry within ±5kHz.

f. Increase s.g. level to 60dB (48dB) and repeat e. The difference between f1 and f2 shall not exceed 250kHz.

Receiver frequency error

77. Specification: ±7kHz of nominal channel frequency.

Method:

a. Connect radio set to t.r.e. as detailed in para 76.a.; wander lead to TP1.

b. Set t.r.e. controls:

CS1	Depressed	CTC6	Depressed
CTC1	RX CW	IF(L)12	Depressed

c. Set s.g. to channel 1 frequency (Tels F 462 Part 2, Table 2014), attenuator 100dB. Switch radio set to channel 1.

d. Adjust s.g. frequency until the d.v.m. reads zero.

e. Note s.g. frequency. It shall be within ±7kHz of the nominal frequency for channel 1.

f. Repeat c. to e. for channel 2 to 6.

Sensitivity

78. Specification

Normal volts: 2µV (114dB), 15kHz deviation at 1000Hz to give ratio $\frac{\text{signal} + \text{noise}}{\text{noise}}$ of at least 20dB.

Low volts: 4µV (108dB), 15kHz deviation at 1000Hz to give ratio $\frac{\text{signal} + \text{noise}}{\text{noise}}$ of at least 20dB.

Method

a. Connect IF(L)16 to SKTU using item 23.

b. Connect CTC20 to SKTX using item 7.

c. Set t.r.e. controls:

CTC1	RX FM	CTC14	SIGNAL ON
CTC2	S + N:N	CTC15	10 (20dB)
CTC7	Depressed	CTC26	INT
		A.F. gen	1000Hz, *150mV

*(Note: 150mV is 15kHz deviation of the s.g.)

- d. Set s.g. frequency to channel 1 (Tels F 462 Part 2, Table 2014), attenuator 114dB.
- e. Set power supply volts to normal (para 63). Switch radio set to NORMAL and channel 1. Note the reading on the d.v.m.
- f. Set CTC14 to MOD OFF, the d.v.m. reading shall be less than that in e.
- g. Repeat d. to f. on channels 2 to 6.
- h. Set power supply volts to low (para 63). Set s.g. attenuator to 108dB and repeat d. to g.

Limiting characteristic

79. Specification

Not greater than 3dB change of output for change in input from 5 μ V (106dB) to 1mV (60dB).

Method

- a. Connect radio set to t.r.e. as detailed in para 78.a. and b.
- b. Set t.r.e. controls as in para 78.c.
- c. Switch set to any convenient channel. Set s.g. to the same channel.
- d. With input to the radio set of 106dB, deviated 15kHz, modulated at 1000Hz, note the reading on the d.v.m.
- e. Gradually increase the s.g. output to 60dB, noting the a.f. output. The a.f. output shall not vary by more than 3dB from the reading in d.

A.F. power output

80. Specification

NORMAL: Not less than 3mW (0.55V) output into 100 Ω for 1mV (60dB) input deviated 15kHz at 1000Hz.

WHISPER: -15dB \pm 3dB of NORMAL

Method

- a. Connect the radio set to the t.r.e. as detailed in para 78.a.
- b. Set t.r.e. controls:

CS1	Depressed	CTC7	Depressed
CTC1	RX FM	CTC26	INT
CTC2	AF LOAD 100	D.V.M.	18V range
		A.F. gen	1000Hz, 150mV

- c. Switch radio set and set s.g. frequency to any convenient channel. Switch radio set to NORMAL.
- d. Set s.g. attenuator to 60dB and note the reading on the d.v.m. It shall be not less than 0.55V (3mW).
- e. Switch the set to WHISPER. The reading on the d.v.m. shall be between 60 and 125mV.

Transmitter tests

R.F. power output

81. Specification

Normal volts: Not less than 275mW

Low volts: Not less than 100mW

Method

- a. Connect the radio set to the t.r.e. as detailed in para 78.a.
- b. Set the t.r.e. controls:

CS1	Depressed	CTC7	Depressed
CTC1	CW	CTC14	• SIGNAL
CTC2	AF LOAD 100	D.V.M.	18V range (This is important)
- c. Set supply voltages to normal (para 63).
- d. Switch the radio set to channel 1 and NORMAL.
- e. Depress CTC11 and note the reading on the d.v.m. It should be at least 0.52V (275mW).
- f. Repeat e. for channels 2 to 6. The d.v.m. reading shall be at least 0.52V (275mW) for all channels.
- g. Set supply voltages to low (para 63) and repeat d. to f., the d.v.m. should read at least 0.32V (100mW) for all channels.
- h. Return supply volts to normal.
- j. On any one channel check with the condition indicator that there is r.f. output at the rod aerial socket SKTW.
- k. If the rod aerial loading coil L3 has been changed or is suspect check that, with a dummy load of 18pF in series with a 50Ω resistor connected between SKTW and chassis, a voltage of at least 3V is developed across the 50Ω resistor. To do this using the t.r.e. carry out l. to m.
- l. Connections to and controls set on the t.r.e. as in a. and b. Connect the Hewlett packard probe (11096) to CTC16-17 and to the junction of the 50Ω resistor and the capacitor of the dummy load. Depress CTC3.

- m. Depress CTC11, the d.v.m. should read at least 3V.

AFC operation

82. Specification

An error of $\pm 250\text{kHz}$ is to be corrected to within $\pm 7\text{kHz}$ of original frequency by a.f.c.

Method

- a. Connect the radio set to the t.r.e. as detailed in para 78.a.

- b. Set t.r.e. controls:

CS1	Depressed	CTC12	RF
CTC1	TX CW		

- c. Switch radio set to channel 1 and note the frequency display on the counter.

- d. Switch off 45V. Increase frequency by unscrewing MO trimmer until the frequency displayed on the counter is that of (c. +250kHz).

- e. Switch on 45V. The frequency displayed on the counter should be within $\pm 7\text{kHz}$ of that in c.

- f. Repeat c. to e. for a decrease in frequency of 250kHz (screw in MO trimmer until the counter displays (c. -250kHz)).

- g. Repeat c. to f. for channels 2 to 6.

Neutralizing

83. Specification

With aerial short circuited the frequency shift to be less than 40kHz.

Method

- a. Connect CTC21 to SKTW and chassis using item 12.

- b. Connect the condition indicator of a dummy load of 18pF and 50 Ω across the rod aerial socket SKTW.

- c. Set the t.r.e. controls:

CS1	Depressed	CTC12	ACCESS
CTC1	TX CW		

- d. Switch off 45V. Switch set to any convenient channel and note the frequency displayed on the counter.

- e. Insert a shorting plug into SKTX and note the frequency displayed on the counter.

- f. The difference between frequencies in d. and e. shall not exceed 40kHz.

Modulation sensitivity

84. Specification

NORMAL: 250mV to give a deviation of 5 to 11kHz.

WHISPER: 25mV to give a deviation of 5 to 11kHz.

Method

a. Connect the radio set to the t.r.e. as detailed in para 78.a.

b. Set the t.r.e. controls:

CS1	Depressed	CTC13	AF
CTC1	MOD S.T.	CTC14	SIGNAL
CTC2	AF LOAD 100	A.F. gen	1000Hz, 750mV
CTC7	Depressed		

c. Switch radio set to any convenient channel. Depress CTC11 and tune the deviation meter.

d. The deviation meter shall read between 5 and 11kHz. The demodulated a.f. from the modulation meter can be viewed on the c.r.o.

e. With set control at WHISPER, set a.f. gen to 1000Hz, 75mV. Depress CTC11, the deviation meter should read between 5 and 11kHz.

Sidetone

85. Specification: 1 mW minimum into 100Ω with input of 250mV on NORMAL.

Method

a. Connect the radio set to the t.r.e. as detailed in para 78.a.

b. Set the t.r.e. controls:

CS1	Depressed	CTC13	AF
CTC1	MOD S.T.	A.F. gen	1000Hz, 750mV
CTC2	AF LOAD 100	D.V.M.	18V range
CTC7	Depressed		

c. Switch set to NORMAL and channel 1. Depress CTC11.

d. The reading on the d.v.m. should be not less than 0.32V.

Frequency error

86. Specification: Nominal channel frequency $\pm 9\text{kHz}$.

Method

a. Connect radio set to t.r.e. as detailed in para 78.a.

b. Set t.r.e. controls:

CS1	Depressed	CTC12	RF
CTC1	CW		

c. Switch radio set to channel 1. Depress CTC11 and note the frequency displayed on the counter.

d. Repeat c. on channels 2 to 6.

e. Referring to Table 2014 (Tels F 462 Part 2) check that each channel is within 9kHz of the nominal frequency for the appropriate model (A or B).

Modulation frequency characteristic (B test)

87. Specification: Deviation obtained with input of 250mV at 1000Hz with set at NORMAL, to be maintained with inputs of 150 to 350mV over frequency range 400Hz to 3kHz.

Method

a. Connect up and set t.r.e. controls as for modulation sensitivity tests para 84.

b. With an a.f. input of 750mV at 1000Hz and set control at NORMAL, check the deviation.

c. Adjust the a.f. generator frequency from 400Hz to 3kHz, maintaining the a.f. gen. output to maintain the deviation obtained in b. The input required should always lie between 150mV (a.f. gen 450mV) and 350mV (a.f. gen 1.5V).

Table 5 - Specification tests after unit replacement

Unit replaced	Specification test	Relevant para
R.F. amplifier mixer	Sensitivity A.F. power output Transmitter frequency error	78 80 86
Crystal oscillator	Sensitivity A.F. power output Transmitter frequency error Receiver frequency error	78 80 86 77
I.F. amplifiers	Sensitivity Selectivity A.F. power output	78 76 80
Limiter	Sensitivity A.F. power output	78 80
A.F. unit	A.F. power output	80
Modulator	R.F. power output Modulation sensitivity Transmitter frequency error	81 84 86
A.F.C. driver	Sensitivity A.F.C. operation Transmitter frequency error	78 82 86
MO, PA valves	R.F. power output Transmitter frequency error	81 86

Note: The next page is page 1001

Note: This Page 1002, Issue 1 is to be fitted immediately after Page 1001, Issue 1 dated 8 Jan 60. The information is additional. Delete 'END' from bottom of Page 1001.

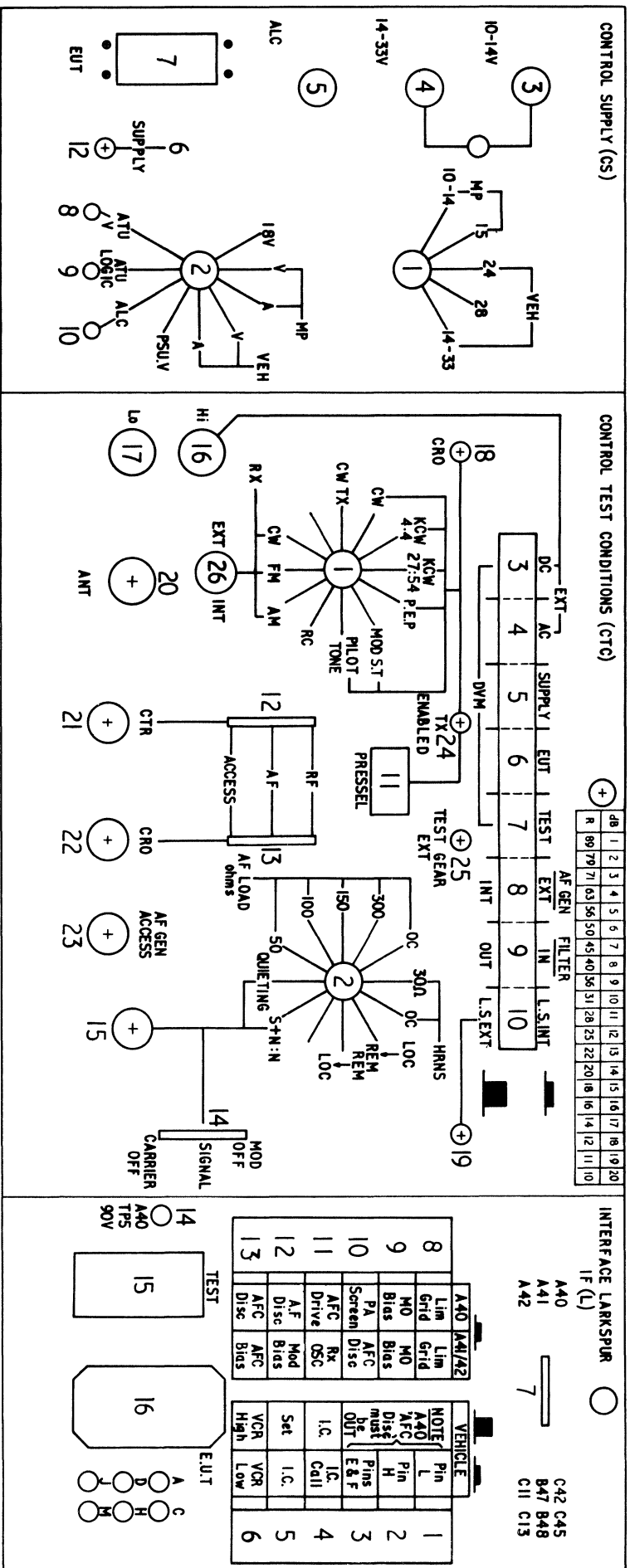

4052/1

Fig 4002 - Front panel layout, Test Controller, fitted with Interface Larkspur

END/8b/4052/Pels

END

Issue 1, Apr 74 (14M)

RESTRICTED

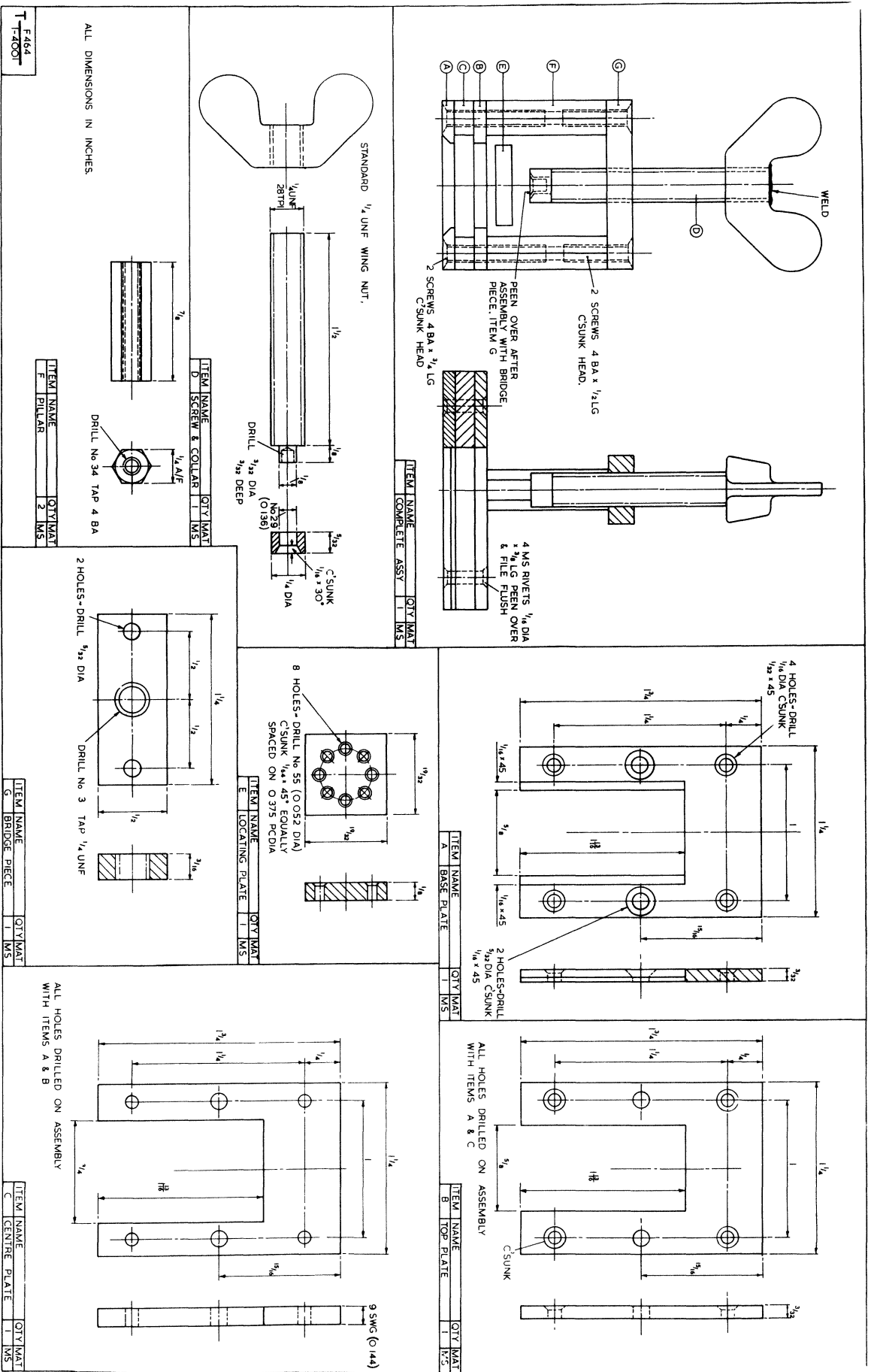

Fig 4001 - Manufacturing details of pin replacement tool