

**RESTRICTED**

The information given in this document is not to be communicated, either directly or indirectly, to the Press or to any person not authorized to receive it.

**RECEPTION SET**  
**R.206 Mk. I**

*Working Instructions*

**ZA 20101**

**The War Office,**  
**Whitehall**  
*October 1945.*

# ERRATA

## **Fig. 2—PLAN VIEW**

*In the Power Supply Unit :—*

*For V1B read V2A*

*For V7A read V1A*

*For V7B read V1B*

# Reception Set R. 206 Mk. I.

## CONTENTS

### CHAPTER I—GENERAL DESCRIPTION

<i>Section</i>	<i>Page</i>
1 Introduction	3
2 Frequency range	3
3 Power supply and consumption	3
4 Power Supply Unit No. 15 controls and connections	3
5 Reception Set R.206 Mk. I controls and connections	4
6 Aerial and earth systems	5
7 Spare valves	6
8 Weights and dimensions	6

### CHAPTER II—OPERATION

9 Preliminary	6
10 Connecting up the power supply	6
11 Operating the receiver	7
12 The reception of weak and jammed signals	8
13 Resetting	10

### CHAPTER III—ROUTINE MAINTENANCE

14 General	11
15 Batteries	11
16 WARNING	11

### TABLE OF TESTS

FOR DAILY MAINTENANCE OF RECEPTION SET R.206 MK. I.	12
--	----

### DIAGRAMS :

- Fig. 1—Reception Set R. 206 Mk. I and Power Supply Unit No. 15—Front View
- Fig. 2—Reception Set R.206 Mk.I and Power Supply Unit No. 15—Plan view.
- Fig. 3—Taking and Resetting from a Vernier Reading
- Fig. 4—Examples of Vernier Readings
- Fig. 5—Reception Set, R.206, Mk. I, R.F. Unit
- Fig. 6—R.F. Turret
- Fig. 7—Power Supply Unit No. 15
- Fig. 8—Reception Set, R.206, Mk. I. IF/AF Unit

### APPENDIX A—LIST OF MAIN COMPONENTS.



# RECEPTION SET R.206 Mk.I

## *General Description and Working Instructions*

### CHAPTER I. GENERAL DESCRIPTION

#### 1. Introduction

The Reception Set R.206 is a high performance superheterodyne receiver capable of high resetting accuracy. The power supply unit is separate from the receiver and contains a small moving coil loudspeaker. Adaptors, Frequency Range, No. 1, may be used with the set to extend the frequency range below the normal frequency range of the set.

#### 2. Frequency range

The frequency range of 30-0.55 Mc/s is covered in six sub-ranges :—

- Range 1—30 -20 Mc/s
- Range 2—20 -10 Mc/s
- Range 3—10.1- 4.8 Mc/s
- Range 4— 4.8- 2.2 Mc/s
- Range 5— 2.2- 1.1 Mc/s
- Range 6— 1.1- 0.55 Mc/s

Adaptors, Frequency Range No. 1 when used in conjunction with the set gives a further frequency range of 600-50 Kc/s in three sub-ranges :—

- Range 7—600-260 Kc/s
- Range 8—260-115 Kc/s
- Range 9—115- 50 Kc/s

#### 3. Power supply and consumption

Power for the Power Supply Unit No. 15 may be A.C. of 110-240 V., 40-60 c/s, or D.C. from a 12 V. source.

When working on A.C. the consumption is 70 watts, and on D.C. 60 watts. These are approximate figures only.

#### 4. Power Supply Unit No. 15 controls and connections

On the front panel (Fig. 1) are :—

POWER ON/OFF switch.

L.S. ON/OFF switch.

A.C./D.C. switch which is placed according to the type of supply being utilised.

POWER OUTPUT plug from which power is supplied to the receiver.

5 amp. fuse, in use when on D.C. supply only.

Two 250 m.A. cartridge type fuses are mounted below the 5 amp. fuse, one in each rectifier anode circuit.

The H.T. voltage for the oscillator is stabilised by means of a neon stabiliser (V2A) which is visible through a window on the front panel. This panel also carries a loudspeaker

On the rear panel (Fig. 2) :—

A.C. INPUT plug.

D.C. INPUT plug, marked + and —.

A.F.R. NO. 1 plug for supplying power to the Adaptor, Frequency Range No. 1 when this is used.

### 5. Reception Set R.206 Mk. I controls and connections

All controls and connecting points are located on the front panel (Fig. 1). These are :—

Main tuning control knob. This has a two-speed drive, the greatest reduction being brought into operation by means of a locking screw. The control is free from backlash.

RANGE CONTROL. To change the range it is necessary to pull the spring loaded knob outwards, rotate the handle through two complete turns either way, and then allow the knob to re-engage. The range in operation is shown in the window marked RANGE by a luminous figure which should be read in conjunction with the ranges shown on tuning drum.

OSC. VERN., control knob which gives a very fine tuning control and will be found very useful for following slight transmitter or receiver drift.

AE. TRIMMER control knob for fine tuning of the aerial circuit.

L.F. GAIN control knob.

H.F. GAIN control knob. This control is inoperative when the A.V.C. system is in use.

BANDWIDTH KC/S three-way switch which selects an I.F. bandwidth of 0.7, 2.5 or 8 Kc/s.

A.V.C. switch. This is a four-way switch and has the following positions when rotated clockwise :—

CW ON —B.F.O. on, A.V.C. on.

OFF —B.F.O. on, A.V.C. off.

RT OFF —B.F.O. off, A.V.C. off.

ON —B.F.O. off, A.V.C. on.

B.F.O. control knob which controls the B.F.O. pitch.

FILTER IN/OUT switch. This controls a 900 c/s filter in the A.F. amplifier—useful when receiving CW.

LIMITER IN/OUT switch by which transient interference may be reduced.

There are the following connecting points :—

POWER INPUT plug for connection to the Power Supply Unit No. 15.

MUTING plug, whereby the receiver is muted either from an associated sender or from its remote control unit. In the latter case a small portion of the sender signal is fed through the receiver so that it can be heard on the speaker or phones.

L.S. 10Ω jack	}	Mounted behind a common cover plate.
PHONES 150Ω jack		
LINE 600Ω jack		

LAMP two point socket giving a 12 V. supply for an operator's lamp.

AERIAL AND EARTH panel. This is a triangular plate situated at the top right hand corner of the front panel. Two of these plates are provided, one fitted with a co-axial socket and the other with three terminals to which aerial and earth connections are made. The former which will normally be fitted in position when the receiver is issued, will be required whenever co-axial cable is used between the receiver and the aerial, or when the frequency range adaptor is in use. By unfastening three screws the plate may be removed, and the other plate plugged in its place. This second plate is the one shown fitted in Fig. 1.

Whichever aerial and earth panel is not in use is stored on the top cover of the power transformer in the power supply unit.

### 6. Aerial and earth systems

It is recommended that the Reception Set R.206 should be used with a suitably designed rhombic aerial (*See* S.R.D.E. Pamphlet No. 374A). This aerial should be fed to the set, via a Transformer, Aerial No. 1 80/800Ω (ZA 13745), Co-axial cable Uni-radio No. 1 or No. 2 being used from the unbalanced side of the transformer to the set terminals.

Failing this a dipole should be used, provided that the frequency coverage required is small, say about 10% either way from the selected midband frequency.

The dipole should be accurately cut for this midband frequency and fed to the set using co-axial cable Uni-radio No. 1 or No. 2, or similar cable having the same characteristic impedance (approx. 80Ω).

The set will work satisfactorily with an inverted L or Wyndham aerial, but the very high performance of which the set is capable must not be expected with these aeriels. The lead-in should be connected to the left hand dipole terminal, and the other dipole terminal linked to the earth terminal. (Fig. 1).

On no account should the Reception Set R.206 be used with a rod aerial unless a proper matching unit is used with it.

The earth system should be as good as possible having low impedance.

### 7. Spare valves

Spare valves are housed in a box which is supported on the underside of the top panel of the receiver case.

### 8. Weights and dimensions

- (1) Power Supply Unit No. 15.

Overall dimensions :—7 in. wide  $\times$  12 $\frac{1}{2}$  in. high  $\times$  14 $\frac{1}{2}$  in. deep

Weight :—43 lbs.

- (2) Reception Set R.206.

Overall dimensions :—25 in. wide  $\times$  13 in. high  $\times$  13 $\frac{1}{2}$  in. deep.

Weight :—100 lbs.

## CHAPTER II. OPERATION

### 9. Preliminary

- (1) See that the three valves and the vibrator of the Power Supply Unit No. 15 and the eleven valves of the Reception Set R.206 are in place correctly as in Fig. 2, and that all valve caps are firmly in position.
- (2) See that correct aerial and earth panel is plugged into the front panel and secured with the screws and then make aerial and earth connection.
- (3) Switch on the loudspeaker or plug in phones.
- (4) Set the POWER ON/OFF switch on the power supply unit to OFF.
- (5) See that the three fuses of the power supply unit are in order.

### 10. Connecting up the power supply

- (1) Connect the POWER OUTPUT plug of the power supply unit to the POWER INPUT plug of the Reception Set R.206, by firmly pushing home the two six point sockets provided.

Power for the Adaptors, Frequency Range No. 1 is taken off the four point plug on the rear panel of the supply unit marked A.F.R. No. 1.

- (2) *A.C. mains operation.*

(a) Set the A.C./D.C. switch to A.C.

(b) Take the power supply unit from its case by first undoing the holding screws at the rear of the case. Remove the power transformer cover (see Fig. 2) by unscrewing the two fixing screws and adjust the primary tapings of the transformer to the voltage of the A.C. supply. Re-screw the cover into position and replace the power supply unit in its case and tighten holding screws.

(c) Connect the two point mains socket to the plug on the rear pane of the supply unit marked A.C.

(d) Remove the vibrator and reinsert it in its holder upside down.



(3) *D.C. operation.*

- (a) Set the A.C./D.C. switch to D.C.
- (b) See that the power transformer cover (Fig. 2) is firmly in place as in (2) (b) above.
- (c) Connect the four point battery socket to the plug on the rear panel of the supply unit marked D.C. INPUT. It is essential that the upper pair of sockets be negative and the lower pair positive as marked on the power supply unit case. If the wrong connections are made the fuse situated on the front panel will blow when set is switched on.
- (d) If necessary insert the vibrator in its holder.

**NOTE: When D.C. Operation is no longer required or when changing to A.C. remove the vibrator and insert it in its holder upside down.**

### 11. Operating the receiver

(1) *For RT and MCW Reception.*

- (a) To light the operator's lamp and warm up the set put the POWER ON/OFF switch to ON. The tuning dial lamp should now light, and after about 30 seconds the neon valve in the power supply unit should strike. Do not continue to operate if the neon lamp fails to light, since this valve is necessary to stabilise the local oscillator of the receiver.
- (b) Set the :—
  - L.F. GAIN to 3.
  - LIMITER switch to OUT.
  - FILTER switch to OUT.
  - BANDWIDTH KC/S switch to 8.
  - A.V.C. switch to RT ON.
- (c) Select the desired frequency band with the RANGE CONTROL.
- (d) On ranges 1 and 2 vary the AE TRIMMER to give maximum output on general noise level. Then do not re-adjust.
- (e) Search for the desired signal by rotating the main tuning control knob.
- (f) On ranges 3 to 6 use the AE TRIMMER control to give maximum signal output.
- (g) Adjust the L.F. GAIN control to give a satisfactory volume level.
- (h) When receiving weak telephony or MCW signals, and when local interference is present, an improvement in reception may be obtained as outlined in Section 12 below.
- (i) The OSC VERN should be used for following slight transmitter or receiver drift, especially on the higher frequency ranges.

(2) *For CW Reception.*

- (a) Switch on the power as in (1) (a) above.
- (b) Set the :—
  - L.F. GAIN to 3.
  - LIMITER switch to OUT.

FILTER switch to OUT.

BANDWIDTH KC/S switch to 2.5.

B.F.O. control knob to zero.

A.V.C. switch to CW OFF.

- (c) Select the desired frequency band with the RANGE CONTROL.
- (d) On ranges 1 and 2 use the AE TRIMMER to obtain the maximum output on general noise level. Then do not re-adjust.
- (e) Search for the desired signal by rotating the main tuning control knob, if necessary using the slow motion drive.
- (f) When this has been found adjust for zero beat note with the slow motion tuning control or OSC. VERN. control. This ensures that the required signal is in the centre of the I.F. passband being used.
- (g) Obtain the required beat note by adjustment of the B.F.O. control.
- (h) On ranges 3 to 6 use the AE TRIMMER control to give the maximum signal output.
- (i) Adjust the L.F. GAIN and H.F. GAIN controls to give best reception and satisfactory volume level.
- (j) If the signal is weak or local interference present an improvement may be obtained as outlined in Section 12 below.
- (k) If either the transmitter or receiver drift, as shown by change of beat note, use the OSC. VERN. control to bring the beat note to the same pitch as was originally chosen. The B.F.O. control should be used when it is desired to alter the beat note.

## 12. Reception of weak and jammed signals

### (1) *General.*

By careful manipulation of the controls it should be possible to read both weak and jammed signals. The general methods to be used are outlined below, but it is pointed out that experience alone will enable the operator to obtain the best results.

### (2) *For RT and MCW signals.*

The following devices are available for giving improvement of reception of RT or MCW. Optimum reception can only be obtained by trying combinations of these devices.

- (a) Use the 2.5 Kc/s bandwidth.
- (b) Put the A.V.C. switch to RT OFF so that the H.F. GAIN control is brought into operation for the manual control of signal strength.
- (c) Put the LIMITER switch to IN.
- (d) For MCW, switching in the L.F. FILTER may help if the note is about 900 c/s.

(3) *For CW signals.*

## (a) Normal procedure.

Experiment with combinations of the following until the best reception of the signal is obtained.

- (i) Use the 0.7 Kc/s bandwidth.
- (ii) Put the LIMITER switch to IN.
- (iii) Use of the L.F. filter may lead to considerable "cleaning-up" of a received CW signal. This filter should only be used in addition to the 0.7 Kc/s bandwidth. To use the L.F. filter adjust the beat note to about 900 c/s with the B.F.O. control and put the FILTER switch to IN. Slight re-adjustment of the B.F.O. control should then be carried out to obtain the loudest signal possible. The peak frequency of the L.F. filter is sharp and easily detectable.

## (b) Searching for a weak or jammed CW signal.

If a CW signal is known to be present in a small frequency band of say 10 Kc/s, searching may be carried out with both the L.F. filter (see (a) (iii) above), and the 0.7 Kc/s bandwidth in the circuit. For this the OSC. VERN. control should be used, and when the signal has been found, careful re-adjustment of the controls should be carried out to obtain the best reception. In the case of jammed signals, separation may be carried out as described in (c) below.

## (c) Eliminating an unwanted signal jamming the wanted one.

If the wanted signal is being jammed by another transmitter different in frequency by as little as 400 c/s, considerable improvement in reception of the wanted signal can be achieved by use of the L.F. filter in conjunction with the 0.7 Kc/s bandwidth. The following method, which depends for its operation on the fact that the L.F. filter has a sharper cut-off on the low frequency side of the peak frequency than on the high side, should be adopted :—

- (i) Tune to a strong CW signal with the L.F. filter and the 0.7 Kc/s bandwidth switched into circuit. Re-adjust the B.F.O. control to obtain the strongest output.
- (ii) Re-tune to the wanted signal. It will be noticed that the jamming signal gives a beat note either on the high or the low frequency side of the wanted one.
- (iii) If the beat note of the jamming signal is on the low frequency side, the wanted signal should be tuned, using the OSC. VERN. control, to give a beat note corresponding to the peak frequency of the L.F. filter.
- (iv) If, however, it is on the high frequency side, then the OSC. VERN. control should be rotated so that the beat note of the wanted signal goes through zero beat and then back to the peak frequency of the L.F. filter. In this way, the jamming signal will be found to be giving a beat of lower frequency than that of the wanted one, and maximum elimination of the jamming signal will have been achieved, as in (iii) above.

### 13. Resetting

(1) *General.*

Once the Reception Set R.206 has been tuned into a signal it will always be possible to return to that frequency with a high degree of discrimination if a vernier reading is taken at the time.

(2) *Resetting apparatus.*

The tuning drum is divided into sections shown by numbers on the extreme right of the rotating frequency indicator. One complete turn of the main tuning dial turns the drum through one division.

The main tuning control scale is divided into a hundred divisions, numbered in an anti-clockwise direction (see Fig. 3).

Just above the main tuning control is the tuning vernier. This has ten divisions which correspond to nine divisions on the main tuning control scale. This vernier enables each division on the main tuning dial scale to be accurately set in tenths.

Thus each division on the tuning drum can be accurately set at any of 1000 intermediate positions.

You are shown how to take and reset a vernier reading in Fig. 3.

## CHAPTER III. ROUTINE MAINTENANCE

### 14. General

- (a) Keep the front panel securing bolts screwed home and the set dry and free from dust and dirt.
- (b) Examine all connectors for fraying especially where they enter plugs or sockets.
- (c) See that all plugs and sockets are clean and that they are pushed fully home.
- (d) Do not disturb the cloth dust cover of the loudspeaker and see that no metallic particles such as iron filings fall near the loudspeaker.
- (e) See that all vibrator and valve spares are correct.
- (f) Check that all switches work freely and correctly.

### 15. Batteries

- (a) Test the battery with the set switched on. If the voltage reading is below 11.5, change and re-charge at once.
- (b) See that topping up is carried out when necessary, according to the instructions in the lid of the battery.
- (c) Examine the terminals and if necessary, clean them and smear lightly with vaseline.

### 16. WARNING

If the set does not work when switched on, for one minute, *switch off immediately*.

Check through Sections 9-11 of Chapter II, and make any necessary corrections. Switch on the set again. *Switch off immediately* if the set still does not work.

If everything is correct *do not switch on again* but report the defect *immediately*.

---

**TABLE OF TESTS FOR DAILY MAINTENANCE OF RECEPTION SET R.206 MK. I.**

Part of Set Tested (1)	Test No. (2)	Test (3)	What should happen (4)	What should not happen (5)	What is likely to be wrong (6)	What to do about it. (7)
Power Supply Unit on D.C.	1	Connect up for 12v. battery working, insert vibrator in socket and put POWER switch to ON.	(1) Vibrator should be heard to start and tuning drum on receiver should light up.	(a) Vibrator: heard to start. Tuning drum does not light up.  (b) Vibrator is not heard to start. Tuning drum does not light up.	(i) 6-pt. connector between supply unit and receiver not fitted.  (ii) Bulb is burnt out.	Plug in firmly.  Replace bulb.
					(i) Lead from battery not plugged in.  (ii) Battery flat	Plug in firmly.  Fit charged battery and recharge flat one.
				(c) Vibrator is not heard to start. Tuning drum lights up.	(i) 5-amp fuse on front panel of supply unit burnt out.  (ii) Vibrator faulty	Re-wire fuse and check polarity of D.C. input plug before switching on again. If fuse blows again report.  Replace with spare.
			(2) After about 30 secs. the neon valve of the supply unit strikes.	The neon valve does not strike	(i) Cartridge type fuses not fitted.	Fit these fuses.

**TABLE OF TESTS FOR DAILY MAINTENANCE OF RECEPTION SET R.206 MK. I—(continued)**

Part of Set Tested (1)	Test No. (2)	Test (3)	What should happen (4)	What should not happen (5)	What is likely to be wrong (6)	What to do about it. (7)
Power Supply unit on D.C. (continued)	1				(ii) Valve at fault.	Replace valve.
					(iii) Cartridge type fuses blown and V1A and V1B need replacing.	Replace the valves and fuses.
					(iv) Internal disconnection of heaters V1A and B. Heaters not alight.	Replace V1A and V1B.
					(v) Internal fault in supply unit.	Report.
Power supply unit on A.C.	2	Connect up for A.C. working, remove vibrator and insert upside down in socket. Put POWER switch to ON.	(1) Tuning drum on receiver lights up.	Tuning drum does not light up.	(i) 6-pt. connector supply unit to receiver not fitted.	Plug in firmly.
					(ii) Lead from mains not plugged in.	Plug in firmly.
					(iii) Mains not switched on.	Switch on.

**TABLE OF TESTS FOR DAILY MAINTENANCE OF RECEPTION SET R.206 MK. I—(continued)**

Part of Set Tested (1)	Test No. (2)	Test (3)	What should happen (4)	What should not happen (5)	What is likely to be wrong (6)	What to do about it. (7)
Power supply unit on A.C.— (continued)	2		(2) After about 30 secs. the neon valve of supply unit strikes.	The neon valve does not strike.	(iv) Bulb burnt out  (See D.C. section above.)	Replace bulb.
Receiver RT reception	3	Tune to a strong RT station on each waveband in turn.	Station heard on phones and speaker	(a) Set dead	(i) One or more valves faulty.	Lift valve caps and see if filaments are lit. Replace any valves which are not lit.  Replace valves in following order, leaving the new valves in position and trying the set after each replacement:— V6A, V4A, V2C, V2B, V1B, V3A, V2A, V1A, V2D, V5A, V2E. When the receiver operates again replace all the original valves one by one, testing the receiver each time, and rejecting valves which render the receiver inoperative.



**TABLE OF TESTS FOR DAILY MAINTENANCE OF RECEPTION SET R-206 MK. I—(continued)**

Part of Set Tested (1)	Test No. (2)	Test (3)	What should happen (4)	What should not happen (5)	What is likely to be wrong (6)	What to do about it. (7)
Receiver RT reception.— (continued)	3			(b) Reception on speaker only.  (c) Reception on phones only.	(i) Faulty phones lead.  (ii) Faulty phones	Repair phone lead.  Fit new phones.
Receiver AE TRIMMER control	4	Adjust RANGE CONTROL handle to any range and, rotate AE TRIMMER knob.	General noise level of output should vary.	Output noise level constant.	(i) AE TRIMMER control knob not rotating spindle.  (ii) Internal fault.	Tighten screws on driving sleeve behind front panel.  Report. Receiver may still be used with reduced efficiency.
Receiver L.F. GAIN control.	5	While tuned in to an RT signal rotate L.F. GAIN rotation.	Volume should vary according to direction of rotation.	Volume does not vary.	(i) L.F. GAIN control knob not rotating spindle.  (ii) Internal fault.	Tighten grub screw.  Report. It may still be possible to use the receiver without using this control.

**TABLE OF TESTS FOR DAILY MAINTENANCE OF RECEPTION SET R.206 MK. I—(continued)**

Part of Set Tested (1)	Test No. (2)	Test (3)	What should happen (4)	What should not happen (5)	What is likely to be wrong (6)	What to do about it. (7)
Receiver H.F. GAIN control	6	While tuned in to an RT signal put A.V.C. switch to RT OFF and rotate HF GAIN control.	Volume should vary according to direction of rotation.	Volume does not vary	(i) H.F. GAIN control knob not rotating spindle. (ii) Internal fault.	Tighten grub screw.  Report. Receiver may still be used (especially with the A.V.C. system in use).
Receiver BAND-WIDTH K/CS. Switch.	7	While tuned in to a strong RT station set BAND-WIDTH K/CS switch from 8 to 2.5 and then to 0.7	Signals remain at almost constant strength with high notes progressively disappearing.	Signals still heard but only faintly with switch on certain positions	Crystal filter defective.	Report. Receiver may still be used with BANDWIDTH K/CS switch in the remaining positions.
Receiver LIMITER Switch.	8	While tuned to a strong RT signal put LIMITER switch to IN.	Output decreases and becomes distorted.	No alteration in output.	Limiter defective.	Report. Receiver may still be used.
Receiver A.V.C. switch.	9	Tune to strong unfading RT signal with A.V.C. switch at RT OFF and with H.T GAIN control at maximum. Then switch to RT ON.	Output should be loud and distorted and then quickly reduced to normal and undistorted.	Output unchanged	(i) Valves V.2.D. and V.5.A. faulty. (ii) A.V.C. switch defective.	Replace these valves.  Report. Set may still be used without A.V.C.

**TABLE OF TESTS FOR DAILY MAINTENANCE OF RECEPTION SET R.206 MK. I—continued**

Part of Set Tested (1)	Test No. (2)	Test (3)	What should happen (4)	What should not happen (5)	What is likely to be wrong (6)	What to do about it. (7)
Receiver CW reception	10	Tune to a CW signal and rotate B.F.O. control.	Whistle is heard varying in pitch as control is moved.	(a) No whistle heard.	(i) Valve V.2.E. faulty	Replace the valve.
				(b) Whistle does not vary.	(ii) Internal fault.	Report, receiver may be used for RT reception.
Receiver FILTER switch	11	Tune to a CW signal and put FILTER switch to IN. Rotate B.F.O. control.	Max. output with beat note of about 900 c/s.	(a) Set goes dead (b) No peak frequency.	(i) B.F.O. knob not rotating its spindle. (ii) Internal fault.	Tighten grub screws.  Report. Receiver may be used for RT reception.
				Filter disconnected Filter defective.	Report. Receiver may still be used without the L.F. filter.	

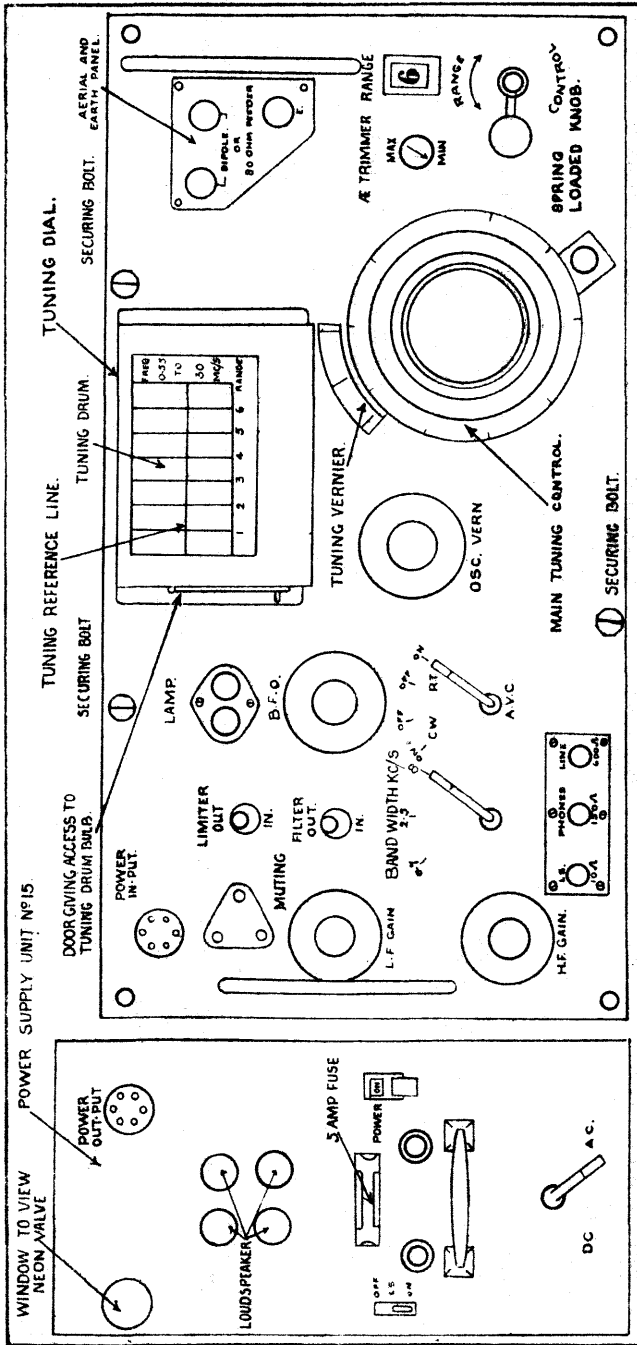

FIG. 1.—RECEPTION SET R.206 MK. I. AND  
 POWER SUPPLY UNIT NO. 15.—FRONT VIEW.

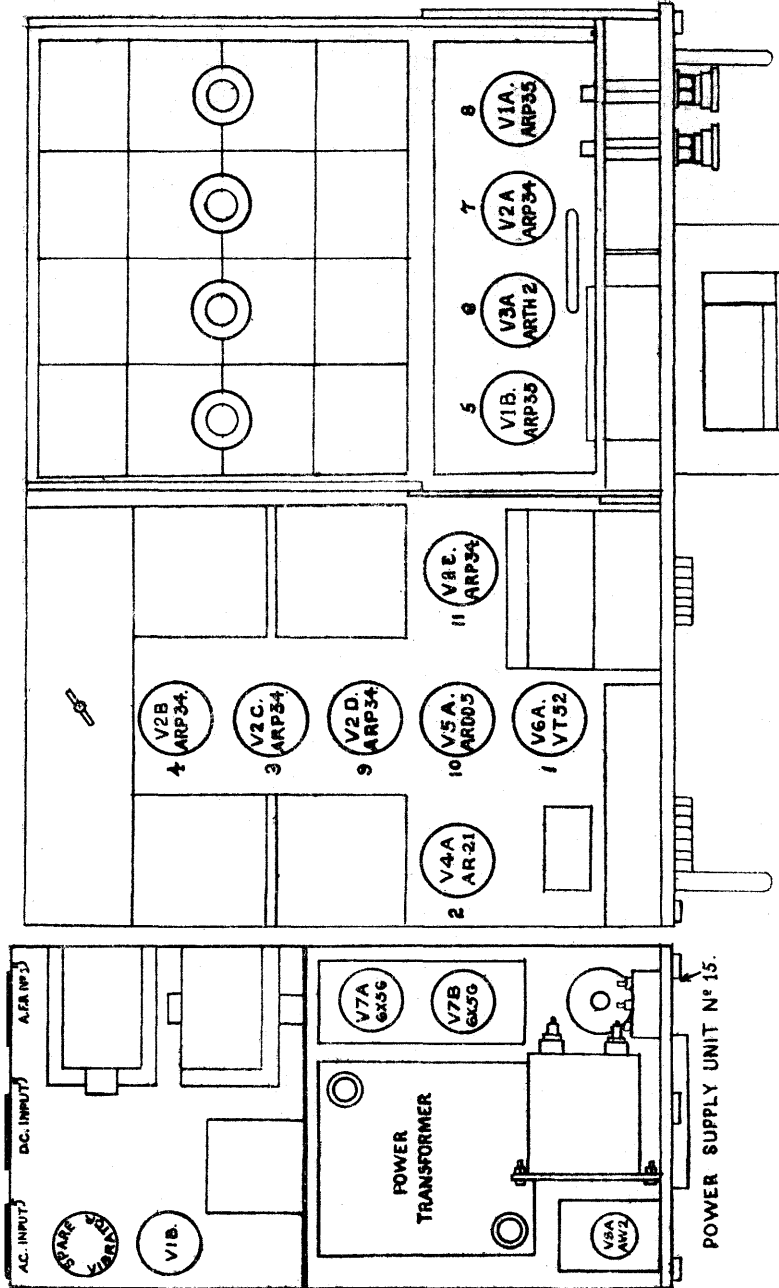

FIG. 2.—PLAN VIEW.  
RECEPTION SET R-206 MK.I and POWER SUPPLY UNIT NO. 15.

## TAKING A VERNIER READING

Set OSC. VERN. control to zero. Using main tuning control, tune accurately to the required signal, using the zero beat method if on CW.

(A) Note which range is in use, this is shown by the figure in the window marked "RANGE"—in this case 1.

(B) On the TUNING DRUM RESETTNG SCALE, note which division the TUNING REFERENCE LINE cuts—here 5.

(C) Note the number of the MAIN TUNING DIAL DIVISION which comes opposite the "O" mark of the TUNING VERNIER. The main tuning dial is marked in an anti-clockwise direction so COUNT FROM RIGHT TO LEFT.

The reading in this case is 32.  
(D) Look along the TUNING VERNIER from RIGHT to LEFT, until you find the mark which is in line with a mark on the main tuning dial—in this case 4.  
Write these four readings down in the form.

1/5/32/4.

You will now be able to return accurately to this setting of the controls whenever you wish as outlined in RESETTNG FROM A VERNIER READING across.

Fig. 3—Taking and resetting from a vernier reading.

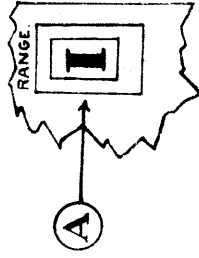
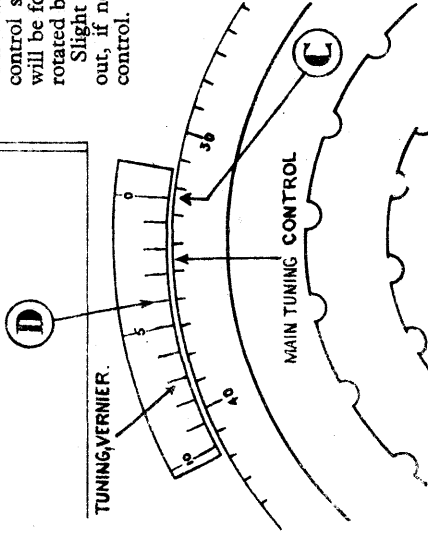
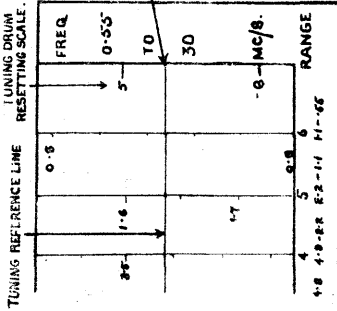

## RESETTNG FROM A VERNIER READING

For example : 1/5/32/4

Set OSC. VERN. control to zero.

(A) Turn the range control to Range 1.

(B) Turn the main tuning dial until number 5 on the TUNING DRUM RESETTNG SCALE coincides with the TUNING REFERENCE LINE.

(C) Rotate the main tuning control CLOCKWISE until mark 32 on the main tuning dial comes opposite the "O" mark on the TUNING VERNIER.

(D) Find mark 4 on the TUNING VERNIER and carefully rotate the MAIN TUNING CONTROL clockwise with the slow motion drive until the mark is directly in line with the first mark of the main tuning control scale to approach it. This position will be found while the main tuning control is rotated between marks 32 and 33.

Slight re-adjustment may now be carried out, if necessary, by using the OSC. VERN. control.

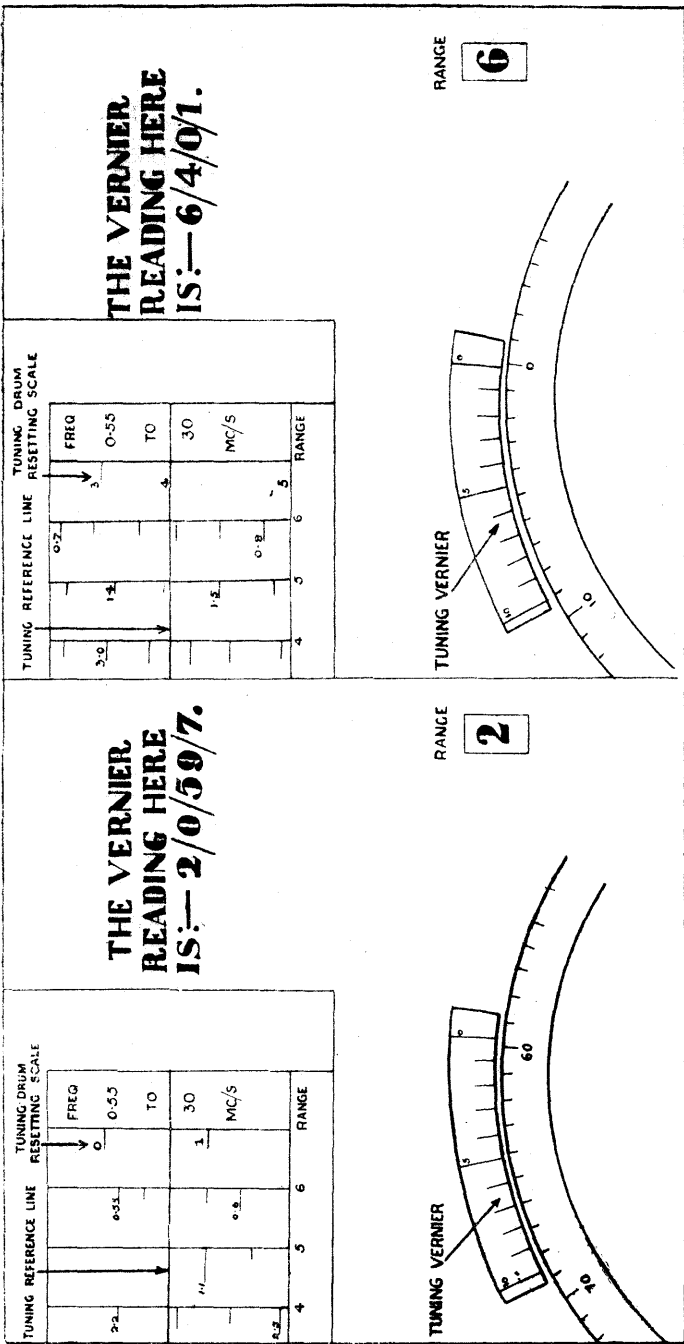

FIG. 4.—EXAMPLES OF VERNIER READINGS





**APPENDIX A.**  
**LIST OF MAIN COMPONENTS.**

**Reception Set R.206 MK. I.**

<i>Component.</i>	<i>Symbol.</i>	<i>Value.</i>	
Condensers.	C1A-D	Gang variable	
	C2A	10 pF	
	C3A-D	10 pF	
	C4A-N	25 pF	
	C5A-L	50 pF	
	C6A	0.5 pF	
	C7A-C	140 pF	
	C8A	150 pF	
	C9A	3000 pF	
	C10A	2580 pF	
	C11A	1150 pF	
	C12A	610 pF	
	C13A	360 pF	
	C14A-B	200 pF	
	C15A-T	0.01 uF	
	C16A	50 pF	
	C17A-C	50 pF	
	C18A	350 pF	
	C19A-E	400 pF	
	C20A	425 pF	
	C21A-S	0.1 uF	
	C22A	20 pF	
	C23A-B	100 pF	
	C24A	500 pF	
	C25A	0.1 uF	
	C26A-B	1000 pF	
	C27A	0.01 uF	
	C28A-B	0.02 uF	
	C29A	10 pF	
	C30A-B	25 uF	
	C31A	100 pF	
	C32A	50 pF	
	C33A-E	0.05 uF	
	Resistors	R1A-D	5K ohms
		R2A-M	1K ohms
R3A-E		500 ohms	
R4A-B		300 ohms	
R5A-D		400 ohms	
R6A-F		0.25 Megohms	
R7A		100 ohms	
R8A-B		75K ohms	
R9A		4K ohms	
R10A-B		30K ohms	
R11A-F		50K ohms	
R12A-B		30K ohms	
R13A-D		100K ohms	
R14A-D		10K ohms	
R15A-B		0.5 Megohms	
R16A		20K ohms	
R17A		200K ohms	
R18A		1 Megohm	
R19A		10K ohms	
R21A		1 Megohm	
R22A		2K ohms	
R23A		30 ohms wire wound on 1000 ohms.	

*APPENDIX A—continued*

**Power Supply Unit No. 15.**

<i>Component.</i>	<i>Symbol.</i>	<i>Value.</i>
<b>Condensers</b>	C1A	1000 uF
	C2A-C	4 uF
	C3A-D	2 uF
	C4A-C	1 uF
	C5A-D	0.5 uF
	C6A-D	0.1 uF
	C7A	.01 uF
	C8A-D	.01 uF
	C9A-E	.01 uF
<b>Resistors</b>	R1A-B	28,000 ohms.
<b>Valves</b>	V1A-B	6X5G
	V2A	AW2
<b>Vibrators</b>	VB1A	Vibrators No. 5.





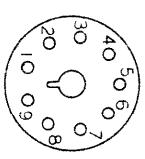
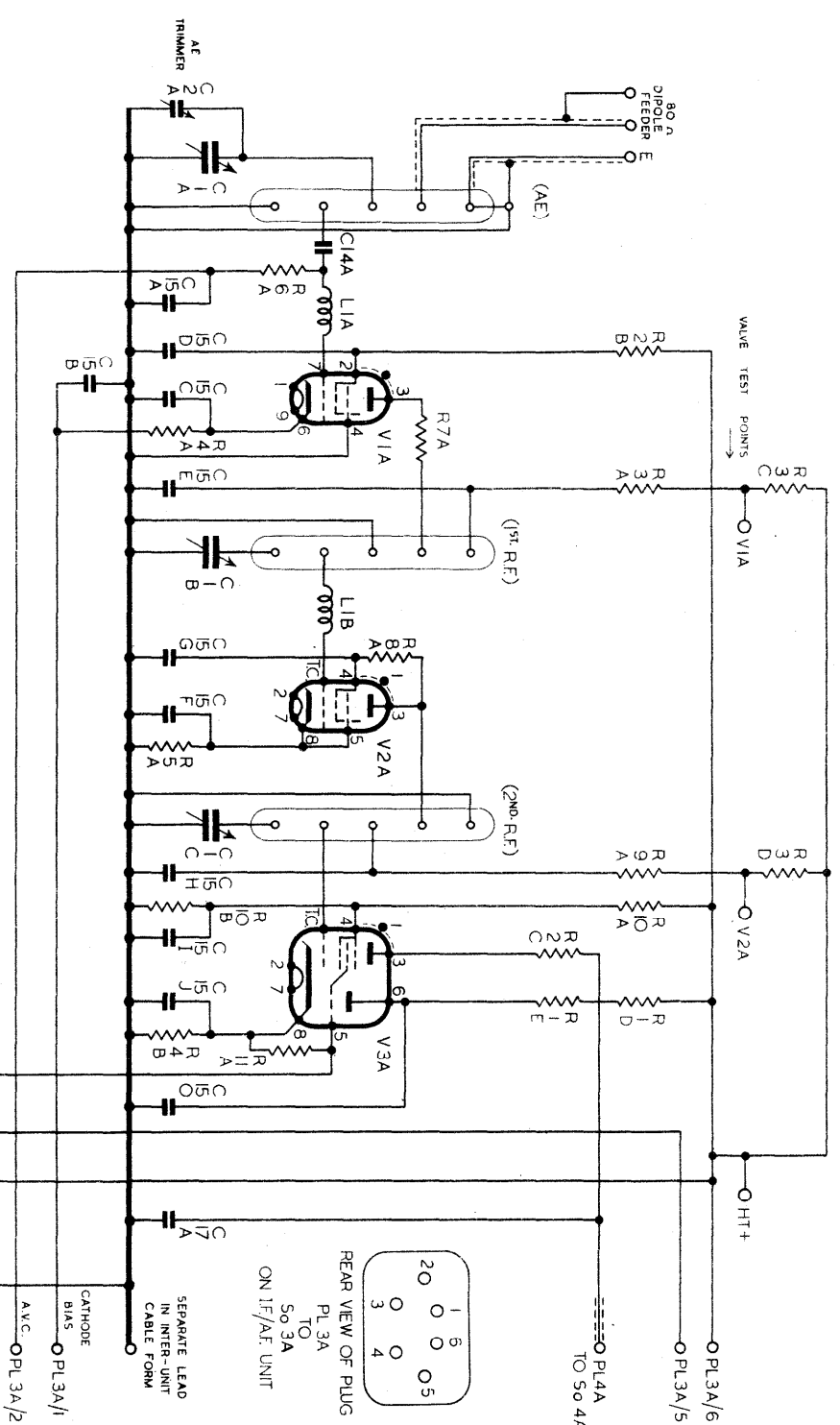

V1 - APP 35  
PINS 5 AND 8 ARE  
CONNECTED TO THE  
INTERNAL SCREENING  
THE SPIGOT EARTHS  
THE EXTERNAL SCREENING

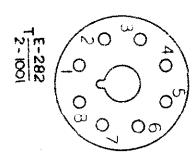

V2 - APP 34  
V3 - ARTH 2  
V1A B  
APP 35

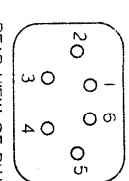
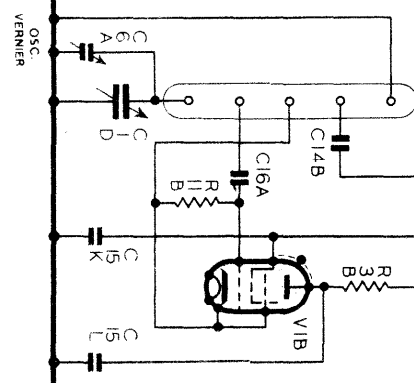
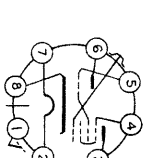
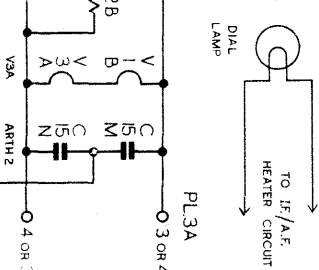
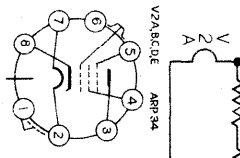

REAR VIEW OF PLUG  
PL 3A  
TO  
50 3A  
ON I/F/A/F UNIT

F4391 F. & C. Ltd. FIG. 5. RECEPTION SET R206. MK. I R.F. UNIT. MEIOW-BU4



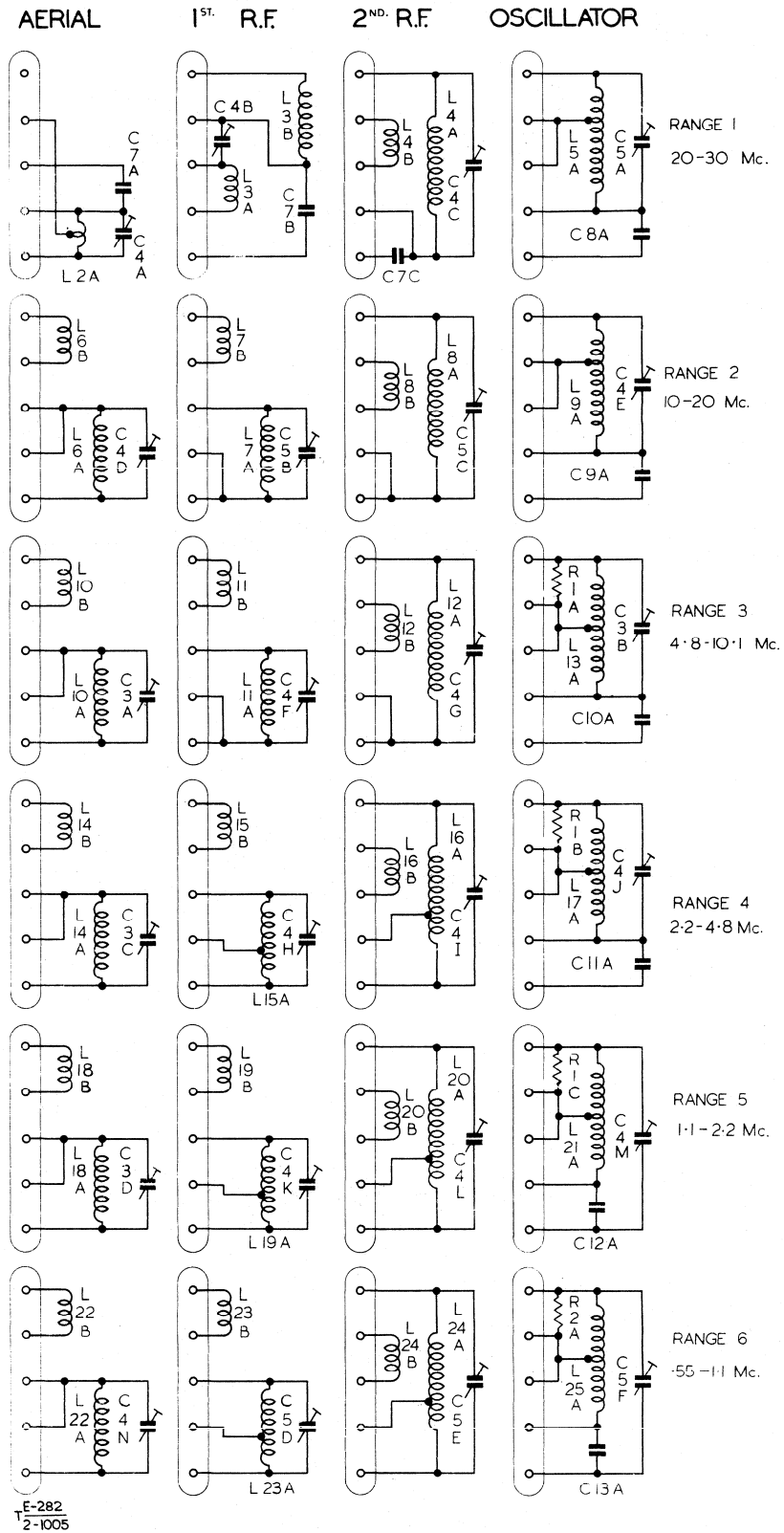

FIG. 6 R.F. TURRET.





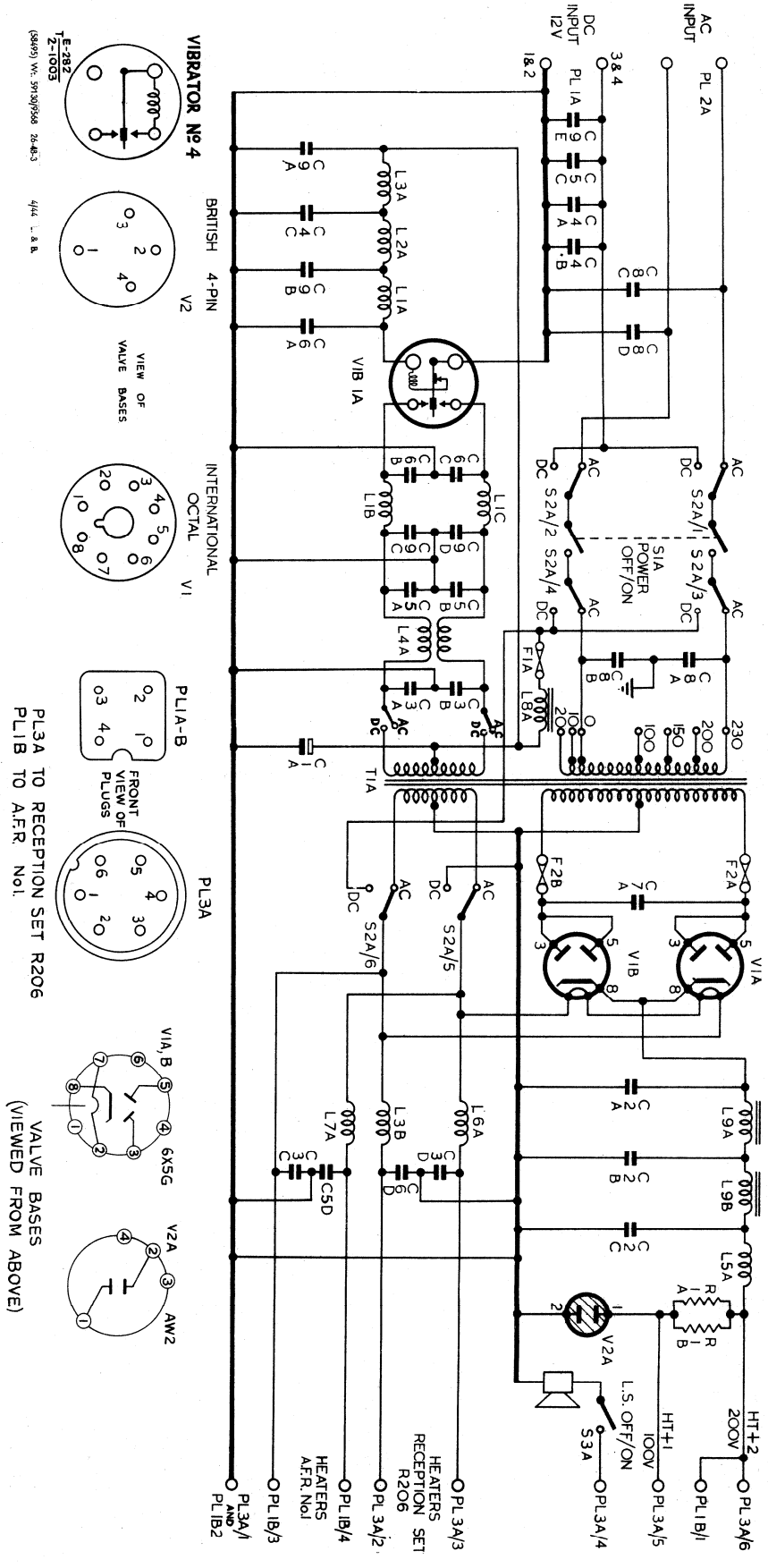
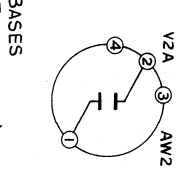
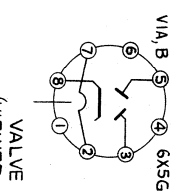
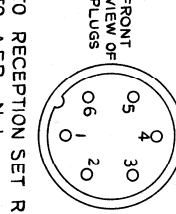
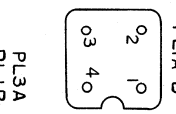
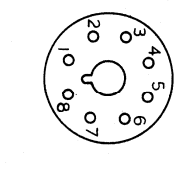
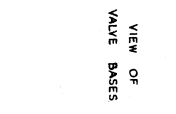
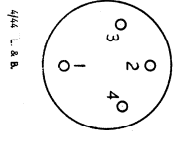
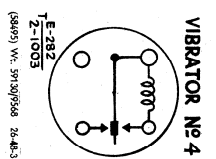

FIG. 7. POWER SUPPLY UNIT No. 15.

MEIOW-BU/2  
 F4371 W4-49989 1300 Z/45 Gp. 959 Foah & Cox Ltd.



PL3A TO RECEPTION SET R206  
 PL1B TO AFR No1.



