

# The VMARS Archive

VMARS is a not-for-profit organisation specialising in all types of vintage communications electronics. We maintain an archive of documentation to help our members understand, research, repair and enjoy their vintage radio equipment. Access by non-members is extended as a gesture of goodwill, but not as a right.

Rare documents are frequently provided free of charge by VMARS members, and all scanning and document processing is carried out on a voluntary basis. Accordingly, we do not expect others to profit from the hard work of volunteers, who give their time freely without charge.

**This is a gentle reminder that the document attached to this notice is provided to you for your personal use only. This edition remains copyright of VMARS, and while you may sell or give your copy to someone else, this right does not extend to making further copies of this information, either to give or sell to others. This includes a prohibition on placing it on websites, or printing it for sale at rallies, boot fairs or similar public events. If our goodwill is abused, then withdrawal of public access to our archive will be the result.**

Please refer anyone else wanting a copy back to VMARS – either to our website at <http://www.vmars.org.uk/> or by email to the Archivist at [archivist@vmarsmanuals.co.uk](mailto:archivist@vmarsmanuals.co.uk). If you want to know more about our copyright, please see the FAQ below.

## FAQ on copyright of VMARS documents

- Q** How can you copyright a document that is already in the public domain?
- A.** *Plainly the original copyright of the content has expired, or we have obtained permission to copy them. What we copyright is our own edition of the document.*
- Q.** Surely your “own edition” is identical to the original document, so cannot be copyrighted?
- A.** *Our editions are **not** identical to the original document. You will find that full advantage has been taken of electronic publishing facilities, so pages are cleaned up where possible (rendering them better than originals in some cases!), and large diagrams are prepared for both on-screen viewing and for easy printing at A4 format.*
- Q.** Why do you not just give your manuals away, as so many do via the internet these days?
- A.** *We do make all our manuals available free of charge (in soft copy) to VMARS members. These members have already covered the costs of running the archive via their subscriptions. The only time members are charged for copies is when they request them on paper, in which case charges are restricted to the cost of paper, ink and postage.*

*The VMARS archive is not a “shoe-string” operation. Money is spent on computing facilities to make copies available, and on shipping original documents securely (usually costing several pounds per shipment) to carry out the scanning. As members have already contributed to these costs, it is only reasonable that non-members should do likewise – and thus a very moderate charge is levied for copies provided to non-members. With typical commercial photocopying charges starting at 5 pence per A4 side, it will be evident that paying 4 pence for our equivalent on paper is excellent value (amounts current at Spring 2004). We also think “you get what you pay for” – we invite you to make the comparison and draw your own conclusions!*

*Despite the above, we will be making copies of essential technical information (circuit diagram, parts list, layout) freely available to all via our website from late 2004 onwards. This will be done to try and encourage and enable the maintenance of our remaining stock of vintage electronic equipment.*

## ***Guidance on using this electronic document***

### **Acrobat Reader version**

You need to view this document with Acrobat Reader **version 5.0** or later. It is possible that the document might open with an earlier version of the Acrobat Reader (thus allowing you to get this far!), but is also likely that some pages will not be shown correctly. You can upgrade your Acrobat Reader by direct download from the internet at <http://www.adobe.com/products/acrobat/readermain.html> or going to <http://www.adobe.com/> and navigating from there.

### **Printing the document on A4 paper**

You should note first that virtually all original documents are in double-sided format, i.e. printed on both sides of the paper. Accordingly, our copies are similarly double-sided., and the best results are obtained if the document is printed double-sided. You can print out on one side only, but you will find that you get a number of blank sheets (which can just be removed and reused), and where margins vary in width between left-hand and right-hand pages, there is a danger of the text disappearing into the binding of your printed copy.

This document is of fairly simple format in that it can be made to print out using an A4 format printer (this is the common paper size available in UK and Europe, which measures 29.7cm by 21.0cm). By "simple" I mean that there are no large diagrams on fold out sheets, which will require multiple A4 pages to print out at full size.

Original document sizes do vary a lot – from the small manuals, which approximate to A5 size (21.0 x 14.8 cm) up to the now obsolete foolscap size (21.6 x 33.0 cm). US documents tend to use their "letter" size paper (21.6 x 27.9 cm). All these sizes can be printed on A4 paper by simply getting Acrobat to shrink or enlarge the pages as necessary. This is done as follows:

1. Select "File – Print" or click on the printer icon. This will bring up the print dialog box.
2. Select the correct printer if necessary.
3. Select the pages you want to print – even if you want to print all of the document, you will probably not want to print this notice and help page, so start the printing at page 3.
4. In the "Page Handling" area, next to "Page Scaling", select "Fit to paper". The press "OK"

### **Printing the document on an US Letter format printer**

Since A4 and US Letter sizes are similar, it is expected that this document should print satisfactorily on the latter format paper. This has not been tested however, and is not guaranteed. Follow the steps as for A4 printing, and make doubly sure that "Fit to paper" is selected (step 4).

### **Any other problems?**

Please get in touch with me at [archivist@vmarsmanuals.co.uk](mailto:archivist@vmarsmanuals.co.uk).

Richard Hankins, VMARS Archivist, Summer 2004

**RESTRICTED**

Army Code No  
11562  
(Revised 1977)

**RESTRICTED**

The information given in this document is not to be communicated, either directly or indirectly to the press or to any person not authorized to receive it

# **USER HANDBOOK FOR WIRELESS SET CI2**

(INCORPORATES AMENDMENT No 1)

---

**WARNING**

The voltages employed in this equipment are sufficiently high to endanger human life. Every reasonable precaution has been observed in design to safeguard operating personnel. The power **MUST** be switched off before changing valves or making internal adjustments. In case of electric shock see inside this book

---

**Published under the authority of:-  
SIGNAL OFFICER IN CHIEF (ARMY)  
Ministry of Defence  
S.W.1**

**Prepared by  
QUALITY ASSURANCE DIRECTORATE (WEAPONS)  
WOOLWICH LONDON  
S.E.18 6ST**

**RESTRICTED**

## AMENDMENT RECORD

AL number	Date of incorporation	Signature	AL number	Date of incorporation	Signature
1	201.01.77	A. X. Bonetti	31		
2			32		
3			33		
4			34		
5			35		
6			36		
7			37		
8			38		
9			39		
10			40		
11			41		
12			42		
13			43		
14			44		
15			45		
16			46		
17			47		
18			48		
19			49		
20			50		
21			51		
22			52		
23			53		
24			54		
25			55		
26			56		
27			57		
28			58		
29			59		
30			60		

## FIRST AID IN CASE OF ELECTRIC SHOCK

### EXHALED AIR METHOD

1. SWITCH OFF. If this is not possible, PROTECT YOURSELF with dry insulating material and pull the victim clear of the conductor. DON'T TOUCH THE VICTIM WITH YOUR BARE HANDS until he is clear of the conductor, but DON'T WASTE TIME.

2.(a) Lay the patient on his back. Quickly loosen waist band and clothing round neck. If his mouth is open, sweep a finger through his mouth to clear obstruction and remove loose dentures.

(b) Lift the head and tilt the head backwards by putting one hand underneath the neck and the other on the crown of the head.

See fig. 1



fig. 1



fig. 2

(c) Hold the head tilted as far back as possible and lift up the jaw firmly, closing the lips. This keeps the victim's airway clear by straightening the breathing passage. See fig. 2

(d) Take a deep breath. Open your mouth as wide as you can. Seal your lips on the victim's cheeks around his nose. Blow air into his nose until you see the chest rise (inspiration).

See fig. 3



fig. 3



fig. 4

(e) Remove your mouth to let him breath out, his chest will fall (expiration).

See fig. 4

(f) Take another deep breath and blow again as soon as he has exhaled, and continue inflations 10 - 15 times a minute. (This is a little slower than the normal rate of 18).

The movement of the victim's chest provides visual confirmation of the success of your efforts.

3. If you fail with the nasal route, try the mouth as follows :-

Lift the jaw and hold his mouth open slightly as you blow, keeping the head tilted well back with the other hand.

Seal your lips around his opened mouth and press your cheek against his nostrils to stop air leakage, and blow until you see the chest rise.

Continue as described in (e) and (f) above until normal breathing returns or medical assistance becomes available.

NOTE DO NOT GIVE LIQUIDS UNTIL VICTIM IS CONSCIOUS

If after 5 or 6 effective inflations of the patient's lungs there is:-

- (i) no improvement in the colour of the face and lips
- (ii) no constriction of the dilated pupils
- (iii) no pulse to be felt in the neck or elsewhere, this means that the heart is not beating:

Carry out External Cardiac Massage

## EXTERNAL CARDIAC MASSAGE

1. (a) Lay the victim on his back on the ground or on some other firm surface.  
(b) Place the heel of one hand, with the other on top of it, on the lower part of the sternum (breast bone) in the mid line of the chest, see note 1. below.

(c) Apply firm pressure vertically downwards aided by the weight of the body, about 60 times a minute.

(d) At the end of each pressure stroke, the hands are to be lifted slightly to allow full recoil of the victim's chest.

(e) Sufficient pressure should be used to depress the sternum an inch or so towards the vertebral column (spine).



2. Artificial respiration must continue simultaneously with external cardiac massage at the rate of about 5 compressions of the heart to one inflation of the lungs.
3. Massage should continue until the victim's pulse is clearly felt and the colour returns to normal, or until medical assistance arrives.

### Notes:

1. Do not attempt cardiac massage if there is obvious damage to the victim's chest wall.
2. There is a real danger of damage to internal organs by the improper use of external cardiac massage.
3. Particular care must be taken with infants and small children, with whom much less pressure is required to depress the sternum than in the case of adults. In these cases the fingers should be used in preference to the palms of the hands.

## SYNOPSIS

The W.S. C12 is basically similar to the W.S. 19 but does not include a 'B' set. It has the same weight and dimensions but a wider frequency range - 1.6 to 10.0 Mc/s - and the working range is approximately equivalent to that of the W.S. 19HP (W.S. 19 and Amplifier R.F. No.2) although the battery drain is considerably lower.

It has an improved 'Flick Frequency' system which provides instantaneous switching from one flick frequency to the other by means of a single control. It may be used with any standard control harness to provide the 'A' set and 'I.C.' facilities, or alternatively can be used without a control harness for ground/truck station roles.

# ILLUSTRATIONS

	<b>Page</b>
Frontispiece ... ..	(viii)
Fig. 1 C12 Output Connectors ... ..	3
Fig. 2 P.S.U. Controls, etc. ... ..	4
Fig. 3 A.T.U. Controls, etc. ... ..	5
Fig. 4 Wireless Set Controls, etc. ... ..	7
Fig. 5 Connections, etc. ... ..	8
Fig. 6 C.W. Keying Unit ... ..	14
Fig. 7 Unit Servicing Log ... ..	16
Fig. 8 Netting Circuit - Block Schematic ... ..	22
Fig. 9 Aerial Circuit ... ..	23
Fig. 10 Aerial Circuit ... ..	24
Fig. 11 Receiver Block Schematic ... ..	25
Fig. 12 Sender ... ..	27
Fig. 13 Heater Circuits ... ..	29 and 43
Fig. 14 Bracket Securing screws ... ..	33

## ASSOCIATED PUBLICATIONS

### Complete Equipment Schedules

Wireless Set C12 (Ground Station Kit) .....	CES 44696
" " " (Basic Kit) .....	CES 45771

### User Handbooks

Wireless Control Harness Type 'A' .....	Army Code No 11374
" " " Type 'B' .....	Army Code No 11195

### Electrical and Mechanical Engineering Regulations

Wireless Set No C12 .....	EMER Tels H140-149
Wireless Control Harness Type 'A' .....	EMER Tels L770-779
" " " Type 'B' .....	EMER Tels L780-789



# CONTENTS

CHAPTER 1	GENERAL DESCRIPTION	Page
1.	Purpose and Facilities ... ..	i
2.	Frequency Range ... ..	2
3.	Aerials ... ..	"
4.	Range of Working ... ..	"
5.	Power Supply and Consumption ... ..	"
6.	General Construction ... ..	3
7.	Weights and Dimensions ... ..	"
8.	Special Connectors ... ..	"
9.	Controls, etc:- Power Supply Unit ... ..	4
10.	"    "    Aerial Tuning Unit ... ..	5
11.	"    "    Wireless Set C12 ... ..	6
<b>CHAPTER 2 OPERATING INSTRUCTIONS</b>		
12.	Preparation ... ..	9
13.	Setting the Flick Switch ... ..	10
14.	Tuning Procedure ... ..	"
15.	Netting Procedure (Voice) ... ..	12
16.	C.W. Operation ... ..	14
17.	Frequency Changing ... ..	15
<b>CHAPTER 3 USER SERVICING AND ADJUSTMENT</b>		
18.	Introduction ... ..	17
19.	Operator's Servicing	
	(1) Suggested Daily Tasks ... ..	17
	(2) Functional Test ... ..	18
20.	User Mechanic's, Servicing (R. Signals Radio Mechanic)	
	(1) Technical Description ... ..	22
	(2) Suggested Monthly Tasks ... ..	31
	(3) Functional Test and Fault Location Procedure	33
<b>APPENDICES</b>		
<b>A</b>	Valves, Relays, etc - Set Unit ... ..	44
<b>B</b>	"    "    " - P.S.U. and A.T.U. ... ..	45
<b>C</b>	Power Supply and Control Circuits ... ..	46
<b>D</b>	Send/Receive Switching ... ..	48
<b>E</b>	Calibration Log ... ..	49

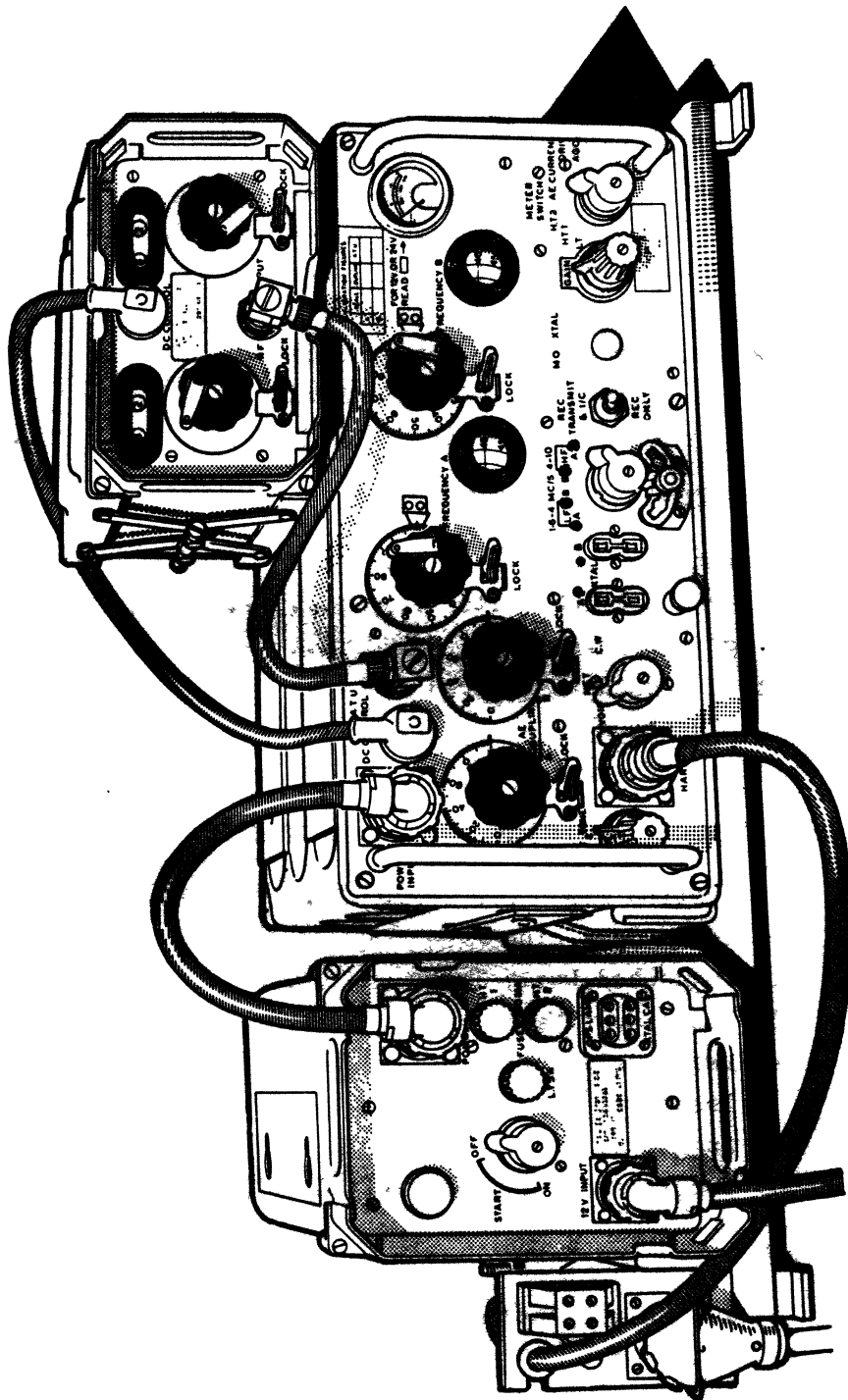

## GENERAL DESCRIPTION

### 1. PURPOSE AND FACILITIES

The W.S. C12 has been provided to fulfil the role of the W.S. 19 HP (W.S. 19 and Amplifier R.F. No.2) in those armoured Fighting Vehicles which cannot accommodate the additional bulk of the Amplifier R.F. No.2. Alternatively the set can be used for general purposes such as a Ground/Truck station etc.

It consists of a VOICE (A.M.)/C.W. Sender/Receiver operating in the high frequency band and an intercom amplifier, and can be connected to any standard control harness to provide the 'A' set and 'I.C.' facilities. The set can be used without a control harness to provide the 'A' set facility and for this purpose a special connector is provided for connecting the operator's headset directly to the 'A' set circuits.

Except for the fact that it has no 'B' set the W.S. C12 is basically similar to the W.S. 19 and is interchangeable with it in most installations. It has, however, a much better overall performance and the sender power compares with that of the W.S. 19 and W.S. 19 HP as follows:-

	W.S. C12	W.S. 19	W.S. 19 HP
VOICE .....	5 Watts	1 Watt	10 Watts
C.W. ....	8 Watts	5 Watts	20 Watts

The set may be pre-tuned to any two alternative frequencies and switched instantaneously from one to the other, as required, without any re-tuning. To provide this facility all tuning controls are duplicated, aerial tuning included, and a single change-over switch is used to transfer the tuning from one set of controls to the other.

Both sender and receiver are tuned by the same controls, and are therefore tuned automatically to the same frequency. The tuning dials are calibrated directly in frequency, and both these and the tuning controls are provided with numbered scales which enable them to be re-set accurately to any previously logged frequency. 'Netting' facilities are incorporated and provision is made for the use of Calibrators Crystal No.10.

The set is equipped for crystal control using external crystals of a frequency 460 kc/s higher than the working frequency. THIS FACILITY IS NOT REQUIRED BY THE ARMY; THE SWITCH HAS THEREFORE BEEN LOCKED IN THE M.O. POSITION AND THE OPERATING KNOB REMOVED.

## 2. FREQUENCY RANGE

The overall frequency range is 1.6 - 10.0 Mc/s and is covered in two bands, 1.6 to 4.0 Mc/s and 4.0 to 10.0 Mc/s. The tuning range of the Aerial Tuning Unit is limited, however, by the length of the aerial used and this is discussed in the following section.

## 3. AERIALS

The set is primarily designed for working into rod aerials but the frequency range of the aerial tuning circuits will depend on the overall length of aerial used, including the length of wire connecting the A.T.U. to the aerial base.

The normal tuning ranges are as follows:-

8 ft. rod or 'V' rod .....	2.0 - 10.0 Mc/s
12 ft. rod .....	1.9 - 10.0 Mc/s
32 ft. vertical .....	1.6 - 6.5 Mc/s

## 4. RANGE OF WORKING

There will be considerable variation in the practical working range depending on frequency, type and length of aerial, nature of intervening country and the amount of radio interference.

The ranges given below have been obtained from the results of trials held to compare the range performance of the W.S. C12 with that of the W.S. 19 HP. These ranges are for VOICE operation and the limited night ranges are due to the heavier interference experienced at night.

	W.S. C12	W.S. 19 HP
Day: Hilly country	15-25 miles	10-15 miles
Open and forested country.	20-40 miles	15-25 miles
Night: All types of country	6-12 miles	5-8 miles

## 5. POWER SUPPLY AND CONSUMPTION

Separate power supply units are available for either 12 V or 24 V operation, and the current consumption is as follows:-

	12 V	24 V
Receiver - Sender and IC Amp OFF	4.6 Amps	2.8 Amps
Receiver - Sender and IC Amp ON	6.9 "	5.0 "
Send - Voice	15.0 "	9.0 "
Send - CW	11.5 "	7.3 "

Sockets on the P.S.U. provide power supplies for a Calibrator Crystal No.10 and also for an operator's lamp.

**6. GENERAL CONSTRUCTION**

The complete equipment is divided into three main parts - the set unit, the power supply unit and the aerial tuning unit. The set and power supply units are housed in modified 19 Set cases and may be mounted on the standard 19 set carrier. The aerial tuning unit is housed in a metal case and a separate mounting frame is provided. This enables it to be mounted in a number of alternative positions on top of the Set Unit, or elsewhere in the vehicle within the limits of the 5 ft. connectors provided.

The cases of all three units are fitted with waterproofing gaskets and all sockets, controls, fixing screws etc., on the front panels are sealed. The tuning controls for flick frequency 'A' are coloured 'Blue' and for flick frequency 'B' 'Red'. All tuning controls are provided with suitable locking devices.

**7. WEIGHTS AND DIMENSIONS**

	Height	Width	Depth	Weight
Set Unit	8 $\frac{1}{4}$ "	17 $\frac{1}{2}$ "	12 $\frac{1}{2}$ "	37 lbs
Power Supply Unit	8 $\frac{1}{2}$ "	6 $\frac{1}{4}$ "	12"	22 lbs
Aerial Tuning Unit	5"	8 $\frac{1}{4}$ "	12"	9 lbs

**8. SPECIAL CONNECTORS**

The HARNESS socket on the wireless set is of the type used with the Control Harness A or B, and will not accept the connectors used with the standard 19 set control harness. In order to use the set with the 19 set type of harness an adaptor (Adaptors, Connectors, 12 pt. No. 1) is provided as shown below.

When the 19 set type of headgear is available the drop lead (Connectors 5 pt. No. 38) may be used to connect the headset direct to the A set without a control harness. (I.C. facilities are not available with this arrangement).

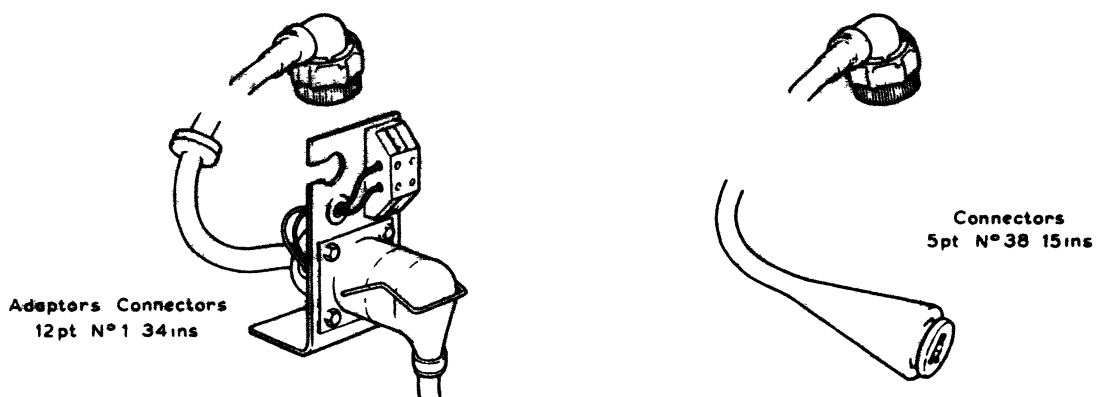

Fig 1

C12 Output Connectors

9. CONTROLS, ETC. - POWER SUPPLY UNIT

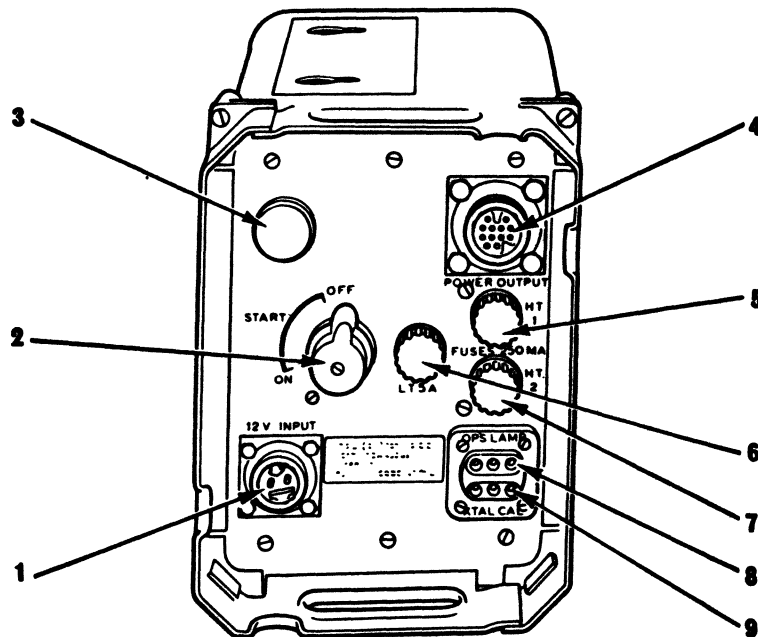

Fig. 2

Location Ref.	Control	Remarks
1	BATTERY INPUT PLUG	For battery connector.
2	ON/OFF SWITCH	Main power switch. The life of the vibrator is lengthened if it is always started at a reduced voltage and the START position is provided for this reason. The speed of starting is such that a deliberate pause in this position is unnecessary.
3	PILOT LAMP	Indicates that the set is switched on.
4	POWER OUTPUT SOCKET	For connecting power supplies to the Set Unit.
5	H.T.1 FUSE	250 mA. fuse for receiver, I.C. Amplifier and sender 250 V. H.T. Circuits.
6	L.T. FUSE	Vibrator fuse - 5A for 12V units, 3A for 24V.
7	H.T.2 FUSE	250 mA. fuse for sender 400V. circuits.
8	OPR'S LAMP SOCKET	
9	XTAL CAL. SOCKET	Power supply for Calibrators Crystal No.10.

10. CONTROLS, ETC. - AERIAL TUNING UNIT

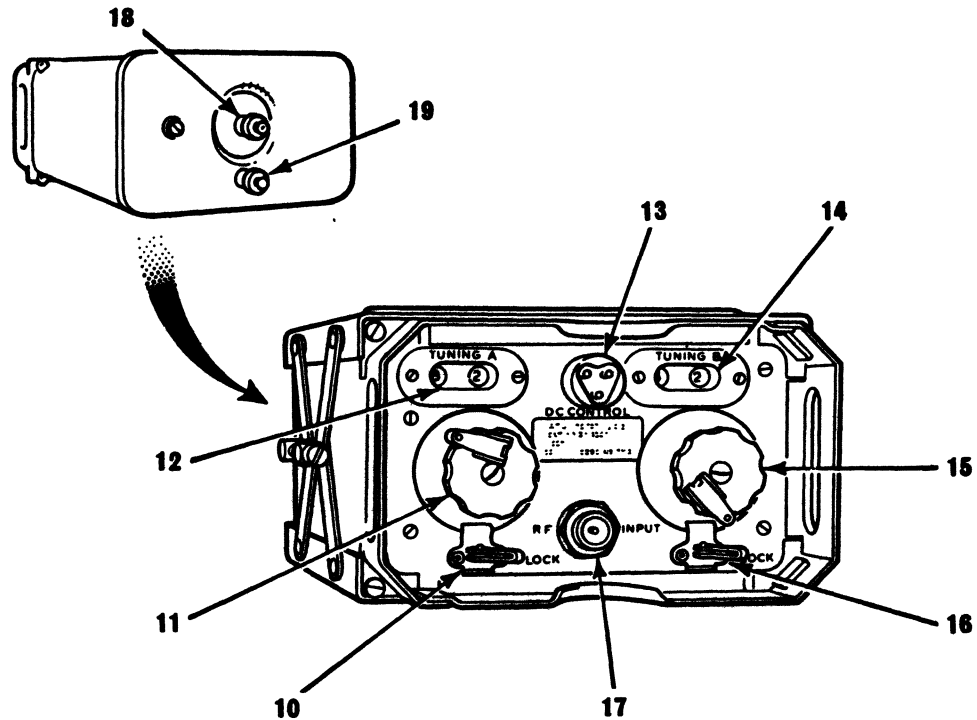

Fig. 3

Location Ref.	Control	Remarks
10	CONTROL LOCK	
11	AERIAL TUNING CONTROL - 'A'	Tunes Aerial circuit for Frequency 'A' - Coloured Blue.
12	TUNING 'A' INDICATOR	Indicates setting of AERIAL TUNING CONTROL 'A' - Coloured Blue.
13	D.C. CONTROL PLUG	Connects with D.C. CON. PLUG (23) on Set Unit.
14	TUNING 'B' INDICATOR	Indicates setting of AERIAL TUNING CONTROL 'B' - Coloured Red.
15	AERIAL TUNING CONTROL - 'B'	Tunes aerial circuit for Frequency 'B' - Coloured Red.
16	CONTROL LOCK	
17	R.F. INPUT PLUG	Connects with R.F. PLUG (24) on Set Unit.
18	AERIAL TERMINAL	
19	EARTH TERMINAL	

11. CONTROLS, ETC. - WIRELESS SET C12

Location Ref.	Control	Remarks
20	POWER INPUT PLUG	For connecting power supplies from P.S.U.
21	AERIAL COUPLING CONTROL - 'A'	Controls the coupling between the set unit and aerial circuit on Freq. 'A'. Coloured Blue.
22	CONTROL LOCK	
23	D.C. CONTROL PLUG	Carries operating current for A.T.U. relays and rectified aerial current for set meter.
24	R.F. PLUG	Connects with R.F. INPUT plug on A.T.U.
25	AERIAL COUPLING CONTROL - 'B'	Controls coupling between set unit and aerial circuit on Freq. 'B'. Coloured Red.
26	CONTROL LOCK	
27	FREQUENCY 'A' TUNING CONTROL	Main tuning control for Freq. 'A'. Coloured Blue.
28	CONTROL LOCK	
29	FREQUENCY 'A' TUNING DIAL	Indicator dial for Freq. 'A' tuning control. Calibrated in Mc/s; provided with logging scale.
30	FREQUENCY 'B' TUNING CONTROL	Main tuning control for Frequency 'B' - Coloured Red.
31	CONTROL LOCK	
32	FREQUENCY 'B' TUNING DIAL	Indicator dial for Freq. 'B' Tuning Control. Calibrated in Mc/s; provided with logging scale.
33	METER	See METER SWITCH (34).
34	METER SWITCH	Switches METER (33) to indicate as follows:- L.T. - Checks battery voltage. Meter may be slightly inaccurate, but true 12V. reading is marked on set panel. H.T.1 - Checks vibrator H.T. output. H.T.2 - Checks rotary transformer H.T. output. A.E. CURRENT - DRIVE - Checks sender at input to final stage. A.G.C.- Checks action of A.G.C. circuit on Voice and of GAIN control on C.W.
35	GAIN CONTROL	Receiver volume control.
36	M.O./XTAL SWITCH	As crystal control is not required this switch has been set to "M.O." and the knob removed.
37	STAND-BY SWITCH	For switching off the sender and I.C. amplifier valves when not required.



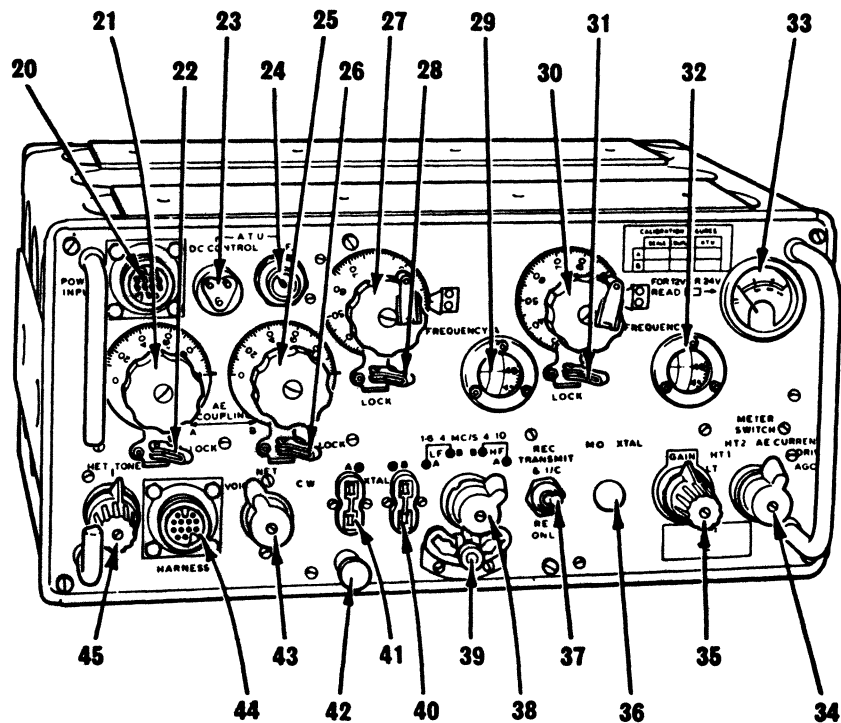

Fig. 4

Location Ref.	Control	Remarks
38	FLICK SWITCH	Combined wave-band switch and Flick Selector switch. (Either the 1.6-4.0 Mc/s band or the 4.0-10.0 Mc/s band may be selected in conjunction with either 'A' or 'B' tuning controls). Used for instantaneous frequency changing.
39	FLICK STOP	Used to restrict the movements of the FLICK SWITCH (38) according to the wavebands of the flick frequencies.
40	XTAL. SOCKET 'B'	For use on crystal control, but not required in the Army version - see M.O./XTAL SWITCH (36)
41	XTAL. SOCKET 'A'	
42	EARTH TERMINAL	For bonding Set Unit to Set Carrier.
43	SYSTEM SWITCH	Switches set for VOICE, NET or C.W. operation.
44	HARNES SOCKET	For connecting microphone, headphone and D.C. control circuits to control harness or head-gear assembly etc. as required.
45	HET. TONE CONTROL	Adjusts pitch of C.W. beat note.



# OPERATING INSTRUCTIONS

## 12. PREPARATION

### (1) Connecting Up

Switch off the ON/OFF switch (2) and connect up the equipment as shown in Fig.5.

### (2) Checking Aerial

The frequency range of the set is dependant upon the aerial used, as shown below.

Check from this that the allotted frequencies are within the frequency range quoted for the aerial to be used.

AERIAL	A. T. U. TUNING RANGE
8 ft. rod	2.0 - 10.0 Mc/s
12 ft. rod	1.9 - 10.0 Mc/s
32 ft. vertical	1.6 - 6.5 Mc/s

### (3) Checking Power Supplies

- (a) Switch the SYSTEM switch (43) to VOICE.
- (b) Switch the STAND-BY switch (37) to Rec, Transmit and IC (UP).
- (c) Switch the control harness - if used - to the correct position for operating the C 12 ("A" set position).
- (d) Switch on the power supply by turning the ON/OFF switch (2) through the START position to the ON position.
- (e) Check that the PILOT lamp (3) lights and that the H.T.1. vibrator in the P.S.U. is heard to start.
- (f) Switch the METER switch (34) to each of the three positions given below and check that the corresponding indication is obtained on the meter.

SWITCH POSITION	METER READING	REMARKS
LT	12 V	If no reading check L.T. fuse. A meter reading of 10.5 V or less indicates a discharged battery.
H. T. 1.	230-270V.	If no reading check H. T. 1. fuse.
With microphone pressel switch pressed:-		
H. T. 2.	370-430V.	If no reading check H. T. 2. fuse.

**13. SETTING THE FLICK SWITCH**

- (1) Press the FLICK STOP (39) and set the FLICK SWITCH (38) to the required 'A' frequency position:-

**EXTREME LEFT**  
if the 'A' frequency is from 1.6 to 4.0 Mc/s.

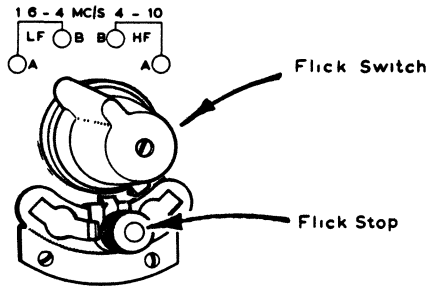

**EXTREME RIGHT**  
if the 'A' frequency is from 4.0 to 10.0 Mc/s.

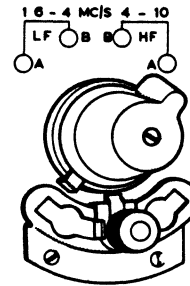

- (2) Press the Flick STOP (39) and set it as follows:-

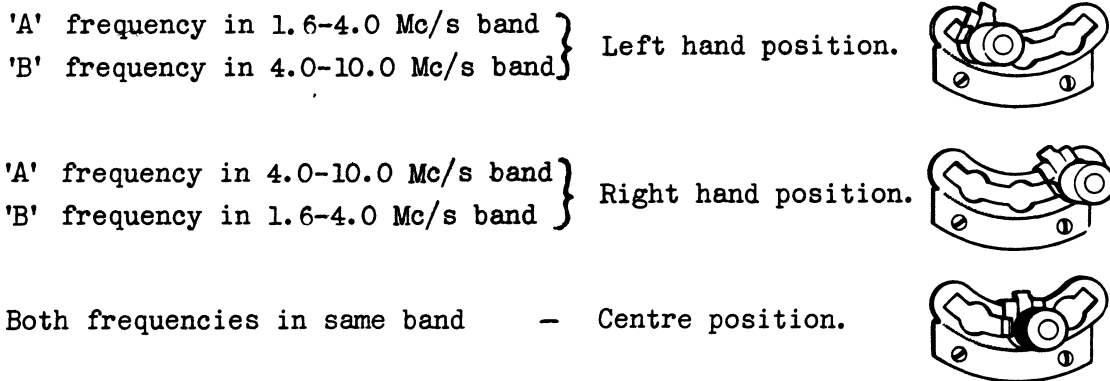

- (3) Check that when the switch is turned in either direction it stops at the correct 'A' or 'B' frequency position.

**14. TUNING PROCEDURE :**

Note:- The following procedure is the same for both frequency 'A' and frequency 'B', but it must be remembered that the BLUE controls must be used when FLICK SWITCH (38) is set for frequency 'A' and the RED controls for frequency 'B'.

- (1) Set the following controls to the positions stated:-  
 SYSTEM SWITCH (43) - VOICE  
 FLICK SWITCH (38) - 'A' or 'B'  
 STAND-BY SWITCH (37) - Rec. Transmit and I.C. (UP)  
 AERIAL COUPLING CONTROL (21 or 25) - 100  
 GAIN CONTROL (35) - Fully clockwise  
 METER SWITCH (34) - AE. CURRENT

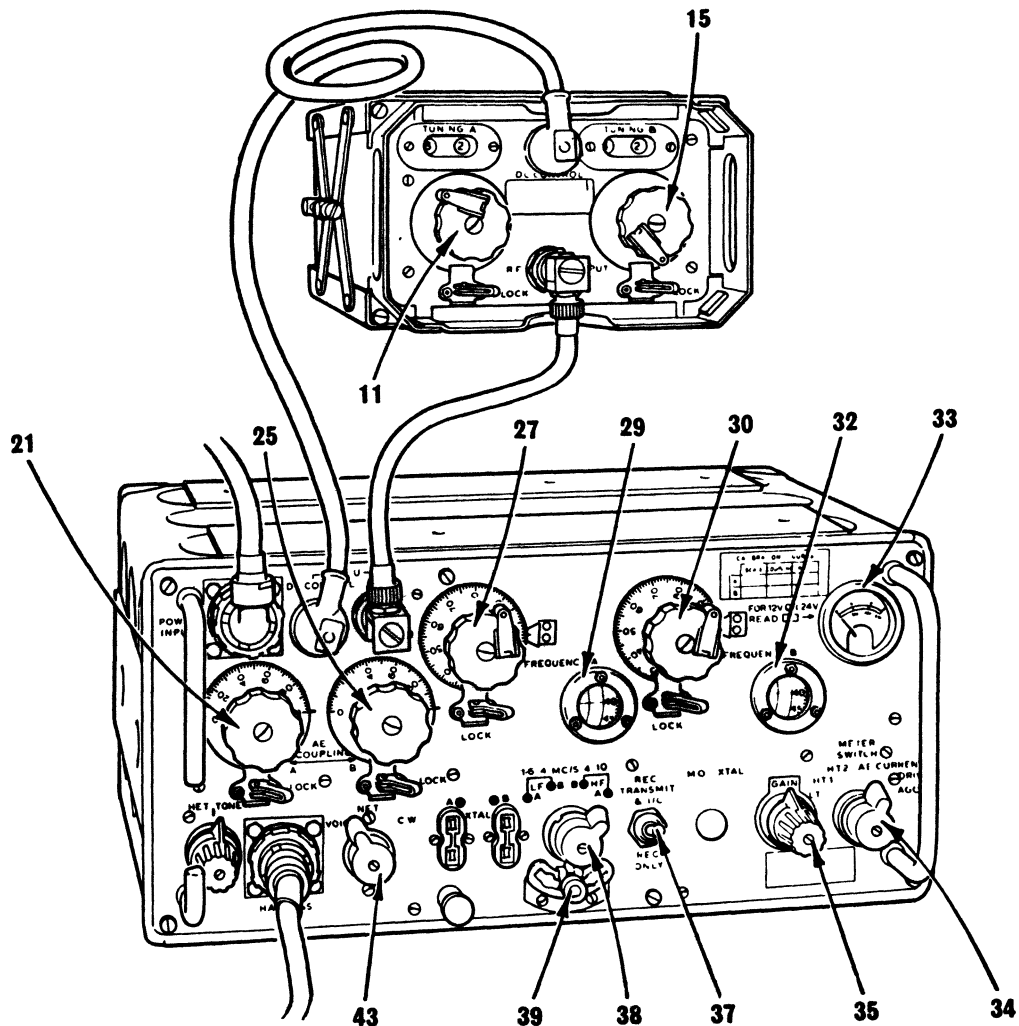

- (2) Unlock the AERIAL TUNING control (11 or 15) and set it as follows:-
 

For frequencies in the L.F. band ....	82
" " " " H.F. band ....	50
- (3) Unlock the FREQUENCY control (27 or 30) and set it to the required frequency as indicated on the FREQUENCY DIAL (29 or 32). Lock the control.
- (4) Press the microphone pressel switch and observe whether any indication of aerial current is obtained on METER (33). If there is an indication adjust the AERIAL TUNING control for maximum reading. If there is no indication rotate the control anti-clockwise until the first indication (see note below) is obtained and then adjust for maximum.

If maximum indication is obtained with the AERIAL TUNING control fully clockwise (this will not occur in the H.F. band) proceed as in para. 6. Otherwise proceed as in para. 5.

THERE MAY BE FALSE TUNING POINTS, WHICH MAY SOMETIMES GIVE HIGHER INDICATIONS OF AERIAL CURRENT, BUT IN FOLLOWING THE ABOVE INSTRUCTIONS THE FIRST TUNING POINT TO BE ENCOUNTERED IS THE CORRECT ONE TO USE.

**(5) Aerial Tuning Control Setting Below 82**

- (a) Turn the AERIAL COUPLING control (21 or 25) slightly clockwise until the meter reading begins to fall.
- (b) Re-adjust the AERIAL TUNING control (11 or 15) for maximum meter reading and note whether there is a slight increase over the reading obtained in para. (4).
- (c) (i) If there is an increase continue repeating the adjustments given in paras. (a) and (b) until no further increase can be obtained. Lock the controls.  
(ii) If there is no increase return the AERIAL COUPLING control (21 or 25) to 100 and re-adjust the AERIAL TUNING control (11 or 15) for maximum current. Lock the controls.

**(6) Aerial Tuning Control Setting At 82**

- (a) Adjust the AERIAL COUPLING control (21 or 25) to obtain maximum aerial current indication on the meter and note the meter reading.
- (b) Rotate the AERIAL COUPLING control (21 or 25) clockwise until a slight reduction in aerial current indication is obtained.
- (c) Re-adjust the AERIAL TUNING control (11 or 15) for maximum reading and note whether there is a slight increase over the reading obtained in para. (a).
- (d) (i) If there is an increase continue repeating the adjustments given in paras. (b) and (c) until no further increase can be obtained. Lock the controls.  
(ii) If there is no increase re-set the AERIAL TUNING control (11 or 15) to 82 and re-adjust the AERIAL COUPLING control (21 or 25) for maximum aerial current. Lock the controls.

**15. NETTING PROCEDURE (VOICE)**

- (1) Tune the set as described in Sec. 14.
- (2) Adjust the GAIN control (35) for a comfortable listening level.
- (3) Rotate the FREQUENCY control (27 or 30) slightly in either direction until the control station's tuning call is heard.

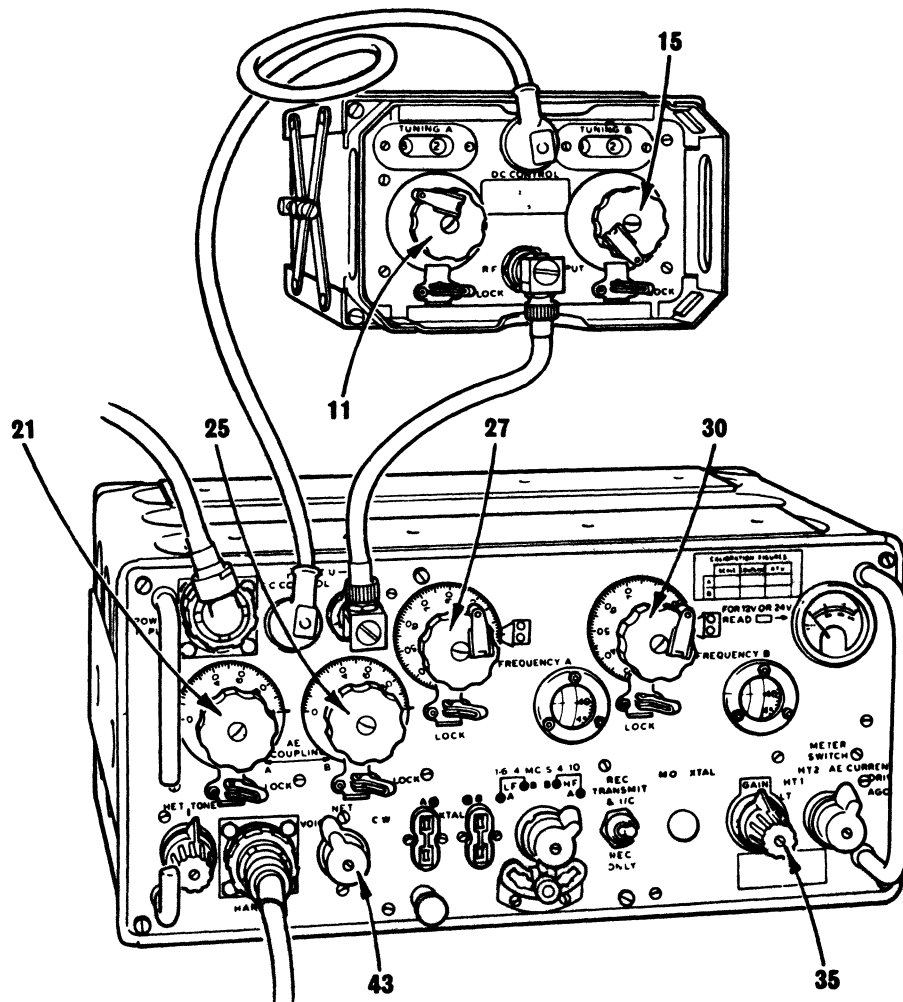

(4) At the commencement of the netting call:-

- (a) Switch the SYSTEM switch (43) to NET.
- (b) Carefully adjust the FREQUENCY control (27 or 30) for zero beat. Lock the control.
- (c) Switch the SYSTEM switch (43) to VOICE.

(5) At the end of the netting call:-

- (a) Un-lock the AERIAL TUNING control (11 or 15).
- (b) Press the microphone pressel switch and carefully re-adjust the AERIAL TUNING control (11 or 15) for maximum reading on the meter. Lock the control.

## 16. C.W. OPERATION

### (1) Preparation

- (a) Prepare and tune the set as described in sections 12, 13 and 14 (Tuning procedure must always be carried out on VOICE).
- (b) Remove the microphone and headgear assembly and in its place connect the snatch-plug from the key assembly.
- (c) Plug the microphone and headgear assembly into the socket on the key assembly (or into the spare drop-lead, where available).

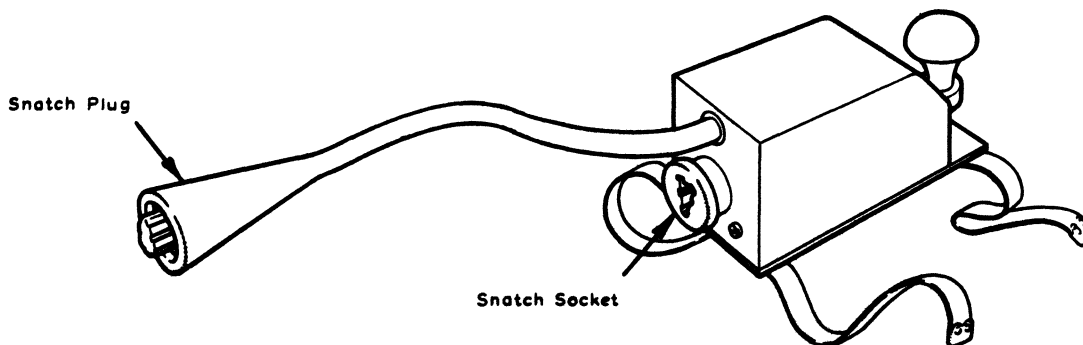

Fig 6

CW Keying Unit

### (2) Netting Procedure

- (a) Switch the SYSTEM switch (43) to C.W.
- (b) Turn the HET.TONE control (45) to the central position.
- (c) Rotate the FREQUENCY control (27 or 30) slightly in either direction until the control station's tuning call is heard.
- (d) Adjust the GAIN control (35) to obtain a satisfactory signal in the headphones. (A very strong C.W. signal may swamp the receiver and result in only a weak note being heard. In this case the GAIN control must be turned down).
- (e) At the commencement of the netting call:-
  - (i) Switch the SYSTEM switch (43) to NET.
  - (ii) Carefully adjust the FREQUENCY control (27 or 30) for zero beat. Lock the control.
  - (iii) Switch the SYSTEM switch (43) to C.W.
  - (iv) Adjust the HET. TONE control (45) to obtain a note of a convenient pitch.



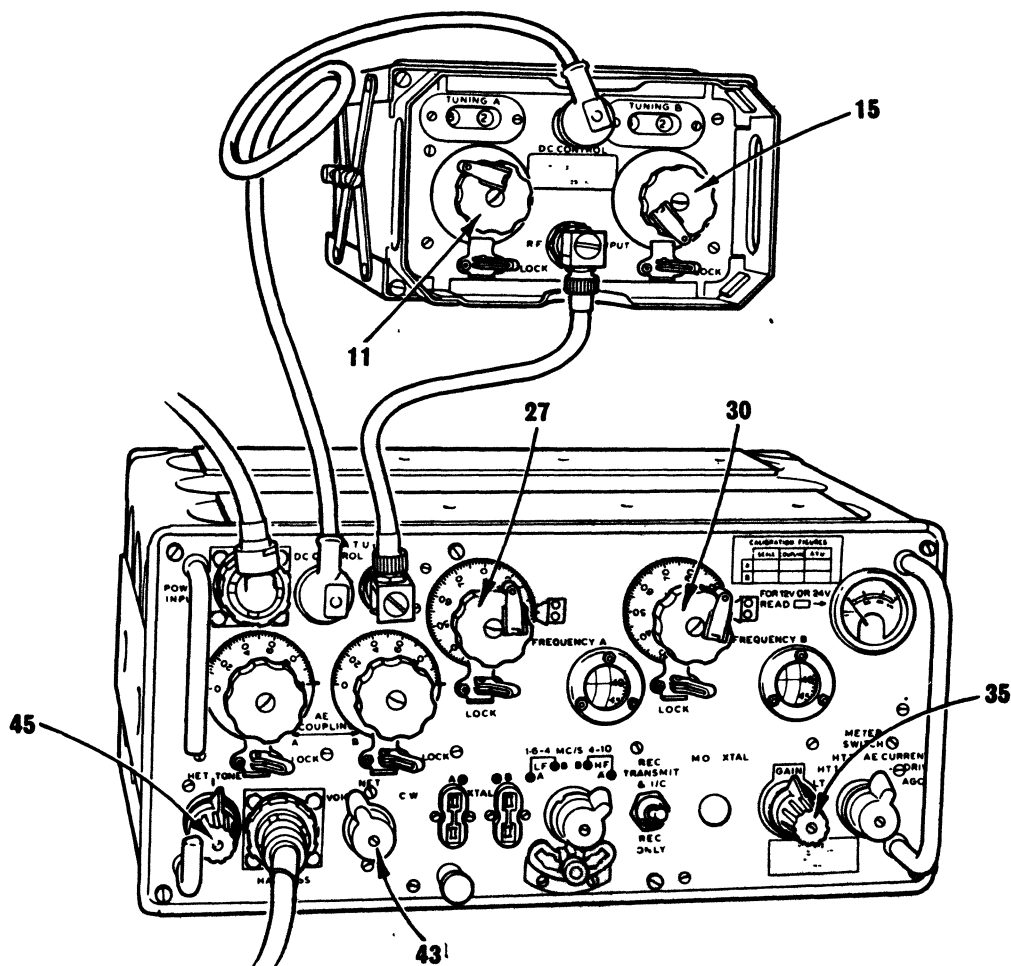

(f) At the end of the netting call:-

- (i) Un-lock the AERIAL TUNING control (11 or 15).
- (ii) Press the morse key.
- (iii) Carefully re-adjust the AERIAL TUNING control (11 or 15) for maximum reading on the meter. Lock the control.

Note:- On C.W. the set is automatically switched to send when the key is down and returns to receive when it is up.

## 17. FREQUENCY CHANGING

When the set has been tuned and netted on both frequency A and frequency B in accordance with the foregoing instructions it is ready for operation on either frequency without further re-tuning. To change frequency it is only necessary to turn the flick switch as far as it will go in the required direction.



## USER SERVICING AND ADJUSTMENT

### 18. INTRODUCTION

No equipment or installation can be expected to work properly unless it is kept in first class condition by regular servicing, conscientiously carried out. This servicing is the responsibility of the N.C.O. or man who is in direct charge of the equipment and responsible for its operation, NOT of workshop or repair staffs, though workshop personnel may be called upon to carry out certain servicing tasks.

To guide the N.C.O. or man responsible for servicing, and to ensure that it is done, it has been laid down that Signal equipment will be serviced on the task system, and that the completion of each task will be recorded on A.F. B2661-Unit Servicing Log.

This log is reproduced on the opposite page. Completion of servicing tasks will be recorded by initialling in the space provided on the front of the form; all minor repairs and replacements will be recorded on the reverse. The form lasts 24 weeks, and replacements should be obtained on indent in the normal way. Current and completed forms should be kept in the pocket in the back cover of this handbook.

The servicing tasks to be carried out daily weekly and monthly for the equipment or installation are listed in the following sections, which show the full servicing required for an equipment in continuous use. In conditions where this does not apply, the frequency with which each task is carried out will be detailed by the Commander concerned.

### 19. OPERATOR'S SERVICING

#### (1) Suggested Daily Tasks

- (a) Check over all external connections and see that plugs and sockets are clean, locking rings tightly screwed up and cables not frayed or badly worn.
- (b) Check that all joints in the rod aerial and the aerial base are clean and tight. Check also the lead from the A.T.U. to the aerial base and, where accessible, the aerial base pigtail to see that all connections are sound.

- (c) Check that the front panel securing screws holding the equipment in its case are tight. (This applies to the screw in each corner of the front panel of the A.T.U. and the P.S.U. - outside the guard - and also to the six screws in the front panel of the wireless set).
- (d) Thoroughly clean all controls and exposed surfaces of the wireless set, A.T.U. and P.S.U. and ensure that all control knobs are tight.
- (e) Inspect all headgear assemblies and morse keys, etc., and clean where necessary. Ensure that all cords are sound and that plugs and sockets are clean and fit properly.
- (f) Check that all four dial lamps are working and report if there are any that do not light.

## (2) Functional Tests

The following routine functional tests should be applied at regular intervals to verify that the equipment is in working order. If any test gives an unsatisfactory result the matter should be reported.

### (a) Check Battery Supply

Switch on the P.S.U. and check that the Pilot Lamp lights and that the vibrator can be heard to start.

*If Neither Operate:*

*-Check all connections from the battery to the Battery Input plug of the P.S.U.*

*If Vibrator Does Not Start:*

*-Replace L.T. fuse (5 A.). If the replacement fuse blows, report.*

*If Pilot Lamp Does Not Light:*

*-Replace bulb.*

### (b) Check L.T. Reading

Switch the Stand-By switch to 'Rec. Trans. and I.C.', the System switch to Voice and the Meter switch to L.T. Check that, after allowing for any meter error recorded on the front panel, the voltage is greater than 10.5 V.

*If There Is No Reading:*

*-Check that the locking rings on the Power connector between the P.S.U. and the set unit are screwed up tightly.*

*If The Voltage Is Low:*

- Remove the plug from the Harness socket on the set unit and check that a relay in the P.S.U. is heard to release and the L.T. reading is REDUCED slightly. If either or both of these results are not obtained, report.
- Check as far as possible that all battery supply connections are clean and tight.
- Charge or replace battery.

(c) Check H.T.1 Reading

Switch the Meter switch to H.T.1 and note the voltage. This reading is dependant on the L.T. voltage but should be within approximately 20 volts (one meter scale division) of the following figures:-

True L.T.	H.T.1 Reading.
10.5 V. ....from	220V.
11.0 V. .... "	230V.
11.5 V. .... "	240V.
12.0 V. .... "	250V.
12.5 V. .... "	260V.

*If There Is No Reading:*

- Replace H.T.1 fuse (250 mA.). If the replacement fuse blows, report.

(d) Check Operation of Rotary Transformer

Switch the System switch to C.W. and check that the rotary transformer in the P.S.U. is heard to start.

- If it does not start, report.

(e) Check Operation Of Microphone Pressel Switch

Switch the System switch to Voice and the control harness (where used) to the 'A' set position. Press the microphone pressel switch and check that the rotary transformer in the P.S.U. is heard to start.

*If It Does Not Start:*

- Try a different headset.
- Check that the snatch plug and all harness connectors are properly connected.

(f) Check H.T.2 Reading

Press the microphone pressel switch, switch the Meter Switch to H.T.2 and note the voltage. This reading is dependant on the L.T. voltage but should be within approximately 20 volts (one meter scale division) of the following figures:-

True L.T.	H.T.2 Reading.
10.5 V. ....from	350
11.0 V. .... "	365
11.5 V. .... "	380
12.0 V. .... "	400
12.5 V. .... "	415

*If There Is No Reading:*

*-Replace H.T.2 fuse (250 mA.). If the replacement fuse blows, report.*

(g) Check Sender Drive

Switch the System switch to Voice, the Meter switch to Drive and the Flick switch to 'A - 1.6/4.0 Mc/s.' Press the microphone pressel switch and check that the set meter indicates at least 100 V. (five small scale divisions). Repeat the same test in the remaining three positions of the flick switch.

(h) Check Chassis Connection from A.T.U. to Set Unit

Switch the Meter switch to Ae. Current and check that there is no meter reading until the microphone pressel switch is pressed.

*If There Is:*

*-Switch the Meter switch to any other position and check that the coaxial connector is properly plugged in at both ends.*

(i) Check Aerial Current

Check that the sender can be tuned up on frequency 'A' and 'B' as described in Chapter 2, Sec. 14, and that normal aerial current indication can be obtained. Check also that all dial lights work.

*If A.T.U. Dial Lights Do Not Light:*

*-Check that the 3-point connector is properly plugged in at both ends.*

*If Aerial Current Cannot be obtained:*

- Check that the Coaxial connector is properly connected.
- Check all aerial and earth connections.

(j) Check Modulation

Press the microphone pressel switch and speak or whistle into the microphone. Check that this produces a slight fluctuation in the meter reading and that side-tone can be heard in the headphones.

*If No Fluctuation or No Side-Tone:*

- Try a different headset.

(k) Check Receiver, B.F.O. and Gain Control

Switch the Meter switch to A.G.C. and the System switch to Net. Check that the set meter indicates about 6V. when the Gain control is fully clockwise and that this indication is reduced to about 4V. as the Gain control is turned right down. Check also that the normal C.W. note can be obtained when signals are tuned in.

(l) Check A.G.C. Action

Switch the System switch to Voice and adjust the tuning to a point at which no signals are received. Check that under these conditions the set meter indicates about 8 V., and that a dip in meter reading is obtained when a signal is tuned in. (The dip will be small for a weak signal but should be quite considerable for a strong one).

(m) Check Het. Tone Control

Switch the System Switch to C.W. and check that the C.W. note obtained when a station is tuned in can be varied by means of the Het. Tone control.

(n) Check I.C. Facilities

Switch all control units to I.C. and check all headsets for speaking and listening, and for speech and buzzer from driver.

(o) Check 'A Set Un-attended' Lamp

Switch all control units to B (or 38/88) and check that the 'A set unattended' lamp lights

*Lamp Does Not Light*

- Replace bulb. If this fails to cure the fault, report.

## 20. USER MECHANIC'S SERVICING (R. SIGNALS RADIO MECHANIC)

### (1) Technical Description

#### (a) Introduction

The Wireless Set C12 is a combined sender and receiver which is tuned automatically to the same frequency on both send and receive. The receiver is a super-heterodyne with an intermediate frequency of 460 kc/s produced, in the customary manner, by tuning the local oscillator to a frequency 460 kc/s higher than that of the incoming signal.

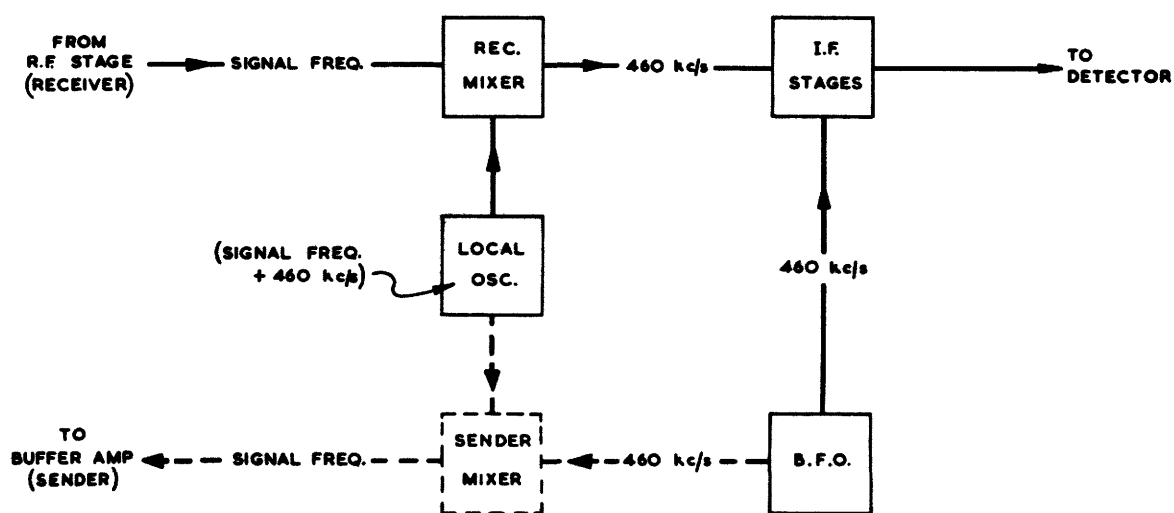

Fig. 8

Block Schematic :- Netting Circuit

To ensure that this tuning is correct the set is provided with 'netting' facilities which, as shown in Fig. 8, consist of an oscillator (the B.F.O.) operating at the intermediate frequency of 460 kc/s and coupled to the I.F. stages of the receiver. A beat note is obtained between the B.F.O. and the intermediate frequency signal and when the receiver is tuned accurately for zero beat the local oscillator frequency will be equal to the incoming signal frequency + 460 kc/s.

The sender frequency is obtained by mixing a portion of the output from the two oscillators in the sender mixer stage and selecting the resulting difference frequency which, when the receiver is accurately 'netted', must always be equal to the incoming signal frequency.



The flick frequency facility is provided by duplicating the ganged condensers, the Aerial Coupling Condenser and the Aerial Tuning Inductance so that when the flick switch is operated the tuning is transferred to the alternative set of controls. In the wireless set the same set of tuning coils is used in both cases.

(b) Aerial Coupling Circuit

This circuit is common to both sender and receiver and is identical to that used on Wireless Sets 22 and 62.

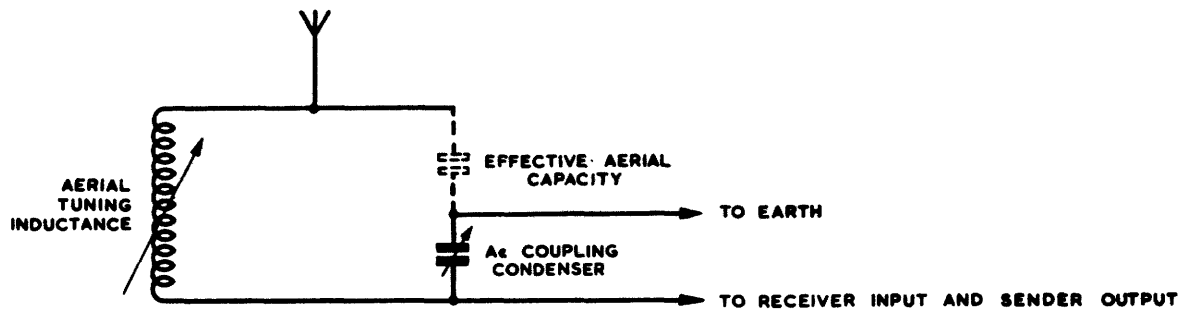

Fig. 9

Block Schematic :- Aerial Circuit

As shown in Fig. 9 above, it consists of the Aerial Coupling Condenser and the effective capacity of the aerial itself in series, tuned by the Aerial Tuning Inductance. The A.T.I. is located in the Aerial Tuning Unit and is the main aerial tuning control; the Aerial Coupling Condenser, located in the set itself, also affects the tuning but its main purpose is to vary the coupling between the wireless set and the aerial circuit. As may be seen in Fig. 9 the earth connection is a tapping point in the circuit which depends for its electrical position in the circuit on the ratio of effective aerial capacity to Aerial Coupling Condenser capacity. When the two are equal the effect of a centre-tapped coil is obtained; if one is three times greater than the other the effect is that of a coil tap a quarter way along, etc. The correct loading for the transmitter Power Amplifier stage - corresponding to maximum aerial current - is only obtained at one setting of the Aerial Coupling Condenser.

On receive the matching conditions are not necessarily the same and incoming signals are invariably strongest when the Aerial Coupling Control is set to 100 (i.e. minimum capacity) but this setting must never be used if it is not correct for the sender as it may result in weak and distorted transmission.

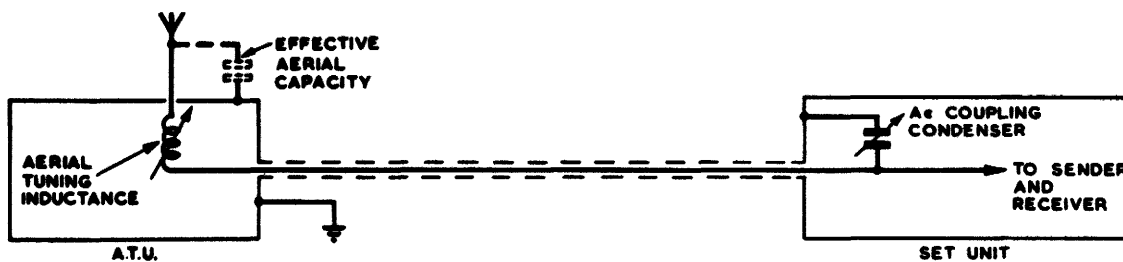

Fig 10

Aerial Circuit

In Fig.10 the aerial circuit has been re-drawn to include the co-axial connecting cable between the set and the Aerial Tuning Unit. The internal capacity of the cable is added to that of the Aerial Coupling Condenser, and its length will therefore have a direct effect on the condenser settings required for maximum aerial current; it may also influence the maximum current obtainable. For this reason it has been laid down that the length must not exceed 5 feet.

### (c) Receiver Circuits

The basic arrangement of the receiver is as shown in Fig. 11 which also shows the valves employed.

- (i) R.F. Amplifier. This is conventional tuned anode amplifier with A.G.C., and it employs a variable-mu pentode CV131 (EF92).

It is capacity-coupled to the R.F. grid of the mixer stage and the anode circuit is tuned by section 2 of the ganged condensers - A or B - counting from the front panel. The aerial circuit is not disconnected on send and so the full R.F. voltage from the P.A. stage of the sender is applied to the grid, but the resulting flow of current is limited to a safe value by the grid leak employed.

- (ii) Frequency-Changer. A triode-heptode CV2128 (ECH81) is employed in which the triode section acts as the receiver local oscillator and also, indirectly, as sender master oscillator. The heptode section, of course, acts as receiver mixer. To prevent frequency drift with variations of battery voltage the oscillator H.T. voltage and the heater current are stabilised by means of a neon - CV287 (QS150/15) and a barretter - CV2293 (UD143) respectively. The oscillator tuning condenser is section 4 of the ganged condensers - A or B - counting from the front panel.

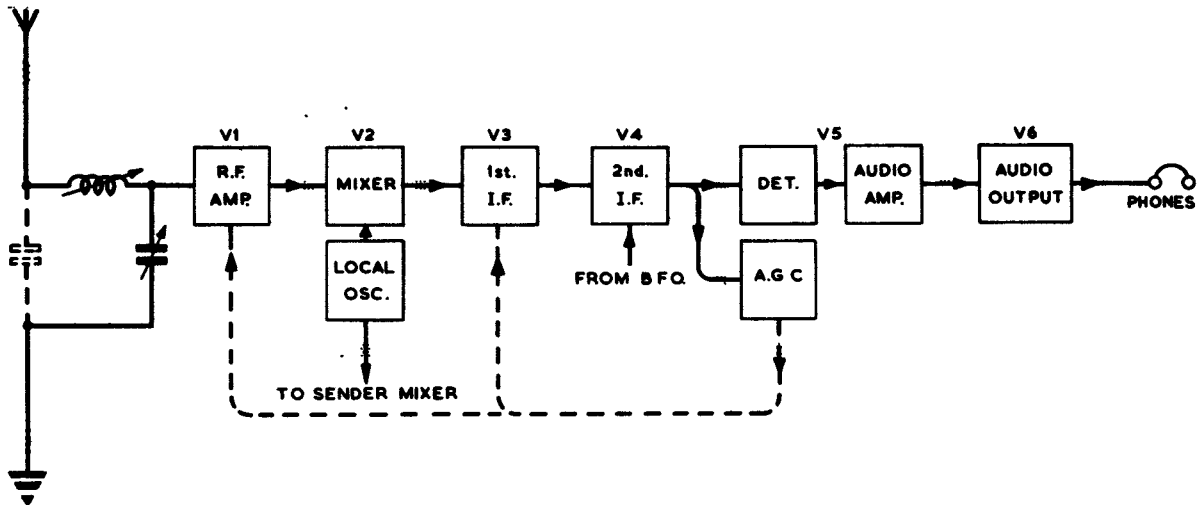

Fig 11

Receiver Block

- (iii) **I.F. Amplifiers.** There are two stages of I.F. amplification, tuned to 460 kc/s and employing variable-mu pentodes CV131 (EF92). A.G.C. is applied only to the first stage.

A portion of the output from the B.F.O. is permanently coupled to the second stage for netting and for C.W. reception, and in order to vary the note on C.W. the B.F.O. frequency may be adjusted by means of the HET. TONE control. (This control is disconnected for netting to ensure that the frequency is exactly 460 kc/s). On Voice operation the B.F.O. is inoperative so long as the set is switched to receive.

- (iv) **Detector A.G.C. and Audio Amplifier.** These three functions are performed by the double-diode triode CV452 (DH77). One diode is used to provide the A.G.C. voltage for the R.F. and 1st I.F. stages; a small delay voltage is applied to this diode to prevent the A.G.C. action from reducing the gain when very weak signals are received. The second diode is used as the detector, the output of which, subject to the setting of the Gain control, is amplified in the triode section. A noise limiter circuit employing a crystal rectifier is incorporated in the triode stage to reduce any sudden surges or pulses of interference which exceed the prevailing signal level.

On C.W. and NET, however, these arrangements are modified. The A.G.C. diode is disconnected and the GAIN control is switched from the detector output circuit to the A.G.C. line, where it is used to control the R.F. and 1st I.F. stages manually and acts, therefore, as an R.F. gain control. Some such arrangement is necessary for good C.W. reception but there

is the disadvantage that, since there is no A.G.C., the set can easily be overloaded (resulting in weak and distorted signals) if the gain control is turned up too high on a strong station, whereas a weak signal can easily be lost if the GAIN control is not turned up sufficiently.

When switched to A.G.C. the set meter indicates the anode current of the A.G.C. controlled valves (R.F. and 1st I.F.). On Voice operation this current depends on the A.G.C. voltage, and is therefore an indication of signal strength, but on C.W. and NET it depends solely on the setting of the GAIN control.

- (v) Audio Output. The audio amplifier is capacity-coupled to the audio output stage which employs a CV136 (FL91). Nominally the output transformer is designed for a 100 ohm load, but in practice this will vary according to the number of headsets actually switched on to the A set. Changes of volume or intelligibility when other headsets are switched in or out have been greatly reduced by the use of negative feed-back in this stage.

#### (d) Sender Circuits

The basic arrangement of the sender is shown in the block diagram in Fig.12, which also shows the valves employed.

- (i) Sender Oscillators and Mixer. As explained in the Introduction the sender drive frequency is obtained by mixing a portion of the output from the receiver local oscillator (operating at signal frequency + 460 kc/s) with a portion of the output from the B.F.O. (operating at 460 kc/s) and selecting the difference frequency, which when the set has been correctly netted must always be equal to the signal frequency. This selection is made by a tuned circuit in the anode of the sender mixer; the tuning condenser is section 3 of the ganged condensers - A or B - counting from the front panel.

A triode-heptode CV2128 (ECH81) is employed, the triode section as B.F.O. and the heptode section as sender mixer.

- (ii) Buffer-Amplifier. The output from the sender mixer is capacity-coupled to the input grid of the buffer-amplifier, which employs two CV 138 (EF91) pentodes. On the 4.0 - 10.0 Mc/s band both valves are connected in parallel, but on the 1.6 - 4.0 Mc/s band a single valve is found to be adequate and so the anode of V9 is disconnected.

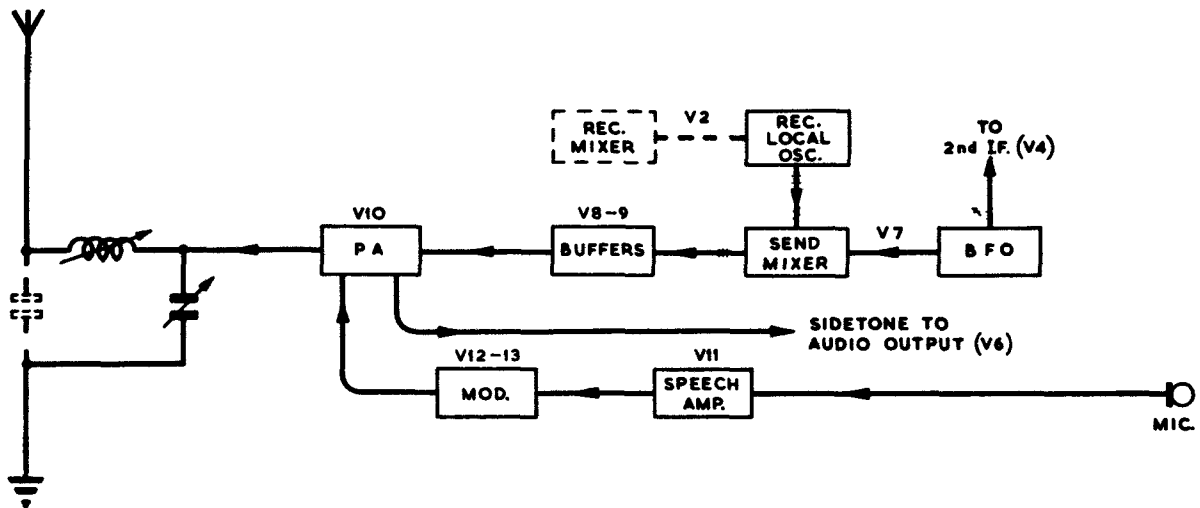

Fig 12

Sender Block

The anode circuit is tuned to resonance by section 1 of the ganged condensers - A or B - (counting from the front panel) and is capacity-coupled to the power amplifier stage.

- (iii) **Power Amplifier.** This stage employs a CV 428 pentode (5B/251M) and supplies the R.F. power to the aerial circuit. On voice operation the H.T. supply is taken through the secondary winding of the modulation transformer, which thus provides anode and screen modulation. No independent tuned circuit is provided for this stage and the aerial tuning circuit is used directly as the anode load.

The valve is operated in Class C, and so the drive from the buffer-amplifier causes a flow of grid current. With the METER switch in the DRIVE position this current is indicated on the set meter.

- (iv) **Modulation.** The microphone circuit is transformer-coupled to a push-pull amplifier stage employing a twin-triode CV492 (12AX7). This is resistance-capacity coupled to a push-pull output stage employing two CV428 (5B/251M) pentodes, and these in turn are transformer coupled to the H.T. supply to the power amplifier stage, thus providing anode and screen modulation. Sidetone is obtained from a cathode resistor in the P.A. stage, which is capacity-coupled to the receiver audio output stage.

No modulation is required on C.W. and NET, of course, and under these conditions the H.T. supply to the modulator stages is switched off.

### (e) Aerial Tuning Unit

Separate Aerial Tuning Inductances are used for A and B frequencies, and they are selected automatically by means of relays controlled from the FLICK SWITCH as explained in para. (f) below.

The lead to the aerial terminal passes through a 'current transformer' which collects a tiny fraction of the aerial current and rectifies it. The resulting D.C. is proportional to the aerial current and is fed back to the wireless set via pin 1 of the 3-point connector, and it is this current which is indicated on the set meter when switched to AE. CURRENT.

The remaining two wires in the 3 point connector are used to operate the two changeover relays and also the pilot lamps which illuminate the A and B tuning indicators. Pin 2 carries the current for the relay which is energised when switched to B frequency (RED), and Pin 3 is used for the relay which is energised when switched to A frequency (BLUE). The common earth return for all three circuits is via the braiding of the co-axial connector.

### (f) Flick Switching

The Flick Switch combines the functions of wave-band switch and frequency-change switch and also switches the Frequency Dial and A.T.U. pilot lamps according to the flick frequency in use.

Within the wireless set it operates directly for all switching other than the changeover from A to B Aerial Coupling control, which is done by a relay operated from the Flick Switch.

In the Aerial Tuning Unit two further relays are operated in the appropriate position of the Flick Switch; one transfers the co-axial input connection and the other transfers the output connection (aerial terminal) to the required Aerial Tuning Inductance. An auxiliary contact on each relay earths the coil not in use.

### (g) Send-Receive Switching

(i) Voice Operation. The operation of the microphone pressel switch energises the 'send/receive' relay and this switches the set from receive to send as follows:-

It disconnects the HET. TONE control and operates a relay in the P.S.U. which starts the 400 V H.T. generator.

It removes the 250 V H.T. supply from the R.F. and I.F. stages of the receiver and connects it to the sender mixer, buffer/amplifier and B.F.O. stages of the sender. It connects the 400 V H.T. supply to the modulator and P.A. stages.

- (ii) C.W. Operation. On C.W. the 400 V start relay is operated directly by the system switch, and so the H.T. generator runs the whole time. The key replaces the microphone pressel switch and operates the send-receive relay in the normal manner, which means that the set is switched to receive each time the key is released and can therefore be used for break-in working.

(h) Heater Circuit

Two separate circuits are used, one for the valves required on receive and the other for those which are only required on send or for I.C. The sender and I.C. valves may be switched off when not required by means of the STAND-BY switch.

The actual circuits are as in Fig. 13, and it will be seen that in most cases the removal or failure of one heater will cause an increase in the current flowing through the remainder. It is therefore advisable to switch off before changing any valve.

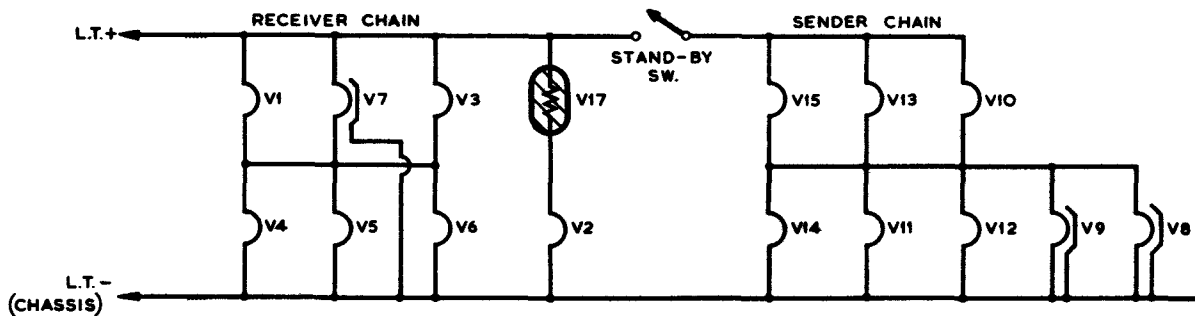

Fig 13 Heater Circuits

(i) I.C. Amplifier

The I.C. microphone circuit is transformer-coupled to a two-stage amplifier employing one CV131 (EF92) pentode resistance-capacity coupled to a CV136 (EL91) output pentode. The anode circuit of the output valve is transformer-coupled to the I.C. headphones circuit and negative feed-back is employed to reduce the effect of load variations when headphones are switched in and out of circuit.

## (j) Power Supply Unit

Separate versions of this unit are manufactured for 12 V. or 24 V. operation but the two types are basically similar. Five main outputs are provided as follows:-

- H.T. supply for sender (400V.)
- H.T. supply for receiver (250V.)
- L.T. supply for receiver (12 V.)
- L.T. supply for sender and I.C. (12 V.)
- Grid bias supply for sender (2V.)

The 250V. (H.T.1.) supply is obtained by using a vibrator and a step-up transformer to convert the battery supply to alternating current at approximately half the required voltage, and then rectifying this in a voltage-doubler circuit employing two CV493 (6X4) rectifiers.

In the START position of the ON/OFF switch a resistance is included in the L.T. supply to the vibrator to limit the initial surge of current when it is first switched on. If this precaution were not taken the life of the vibrator would be materially reduced, but on the other hand the speed of starting is such that no deliberate pause in the START position is necessary.

For the 400 V. (H.T.2) supply a rotary transformer is used.. When the pressel switch is pressed the send/receive relay in the wireless set operates a 'starter' relay in the supply unit which starts the rotary transformer, except on C.W. where the starter relay is operated by a contact on the system switch.

Both the vibrator unit and the rotary transformer unit are fitted with suppressors in the input and output circuits to prevent radio interference, and in both instances the fuse is connected in the final smoothed and filtered output lead.

In the 24 V. version of the supply unit a different vibrator pack and rotary transformer are used and voltage-dropping resistances are included where necessary in the 12 volt circuits. The wireless set therefore continues to operate as from a 12 volt P.S.U. and the set meter still indicates 12 V. when switched to LT.



## **(2) Suggested Monthly Tasks**

### **(a) Accessories**

- (i) Connectors.** Inspect all connectors used with the wireless equipment (and control harness where applicable). Look for any sign of damage or excessive wear and tear, tighten any loose clips or locking rings, etc., and clean any dirty or corroded plugs and sockets.
- (ii) Headgear and Key Assemblies.** Check thoroughly for any signs of damage and see that all leads are sound and contacts clean.
- (iii) Aerial Base.** Open up and inspect pigtail. Ensure that connections are sound and replace pigtail if there are signs of excessive wear.

### **(b) Aerial Tuning Unit**

- (i) Aerial Tuning Inductance.** Carefully clean the rod, wheel and wire using a soft dry and clean cloth. Clean the rotary contacts at the end of the coil with Servisol. Rotate the coil to the stop at either end and ensure that the wheel is then resting on the end turn of the coil. Check also that the tuning indicator registers '82' at one end and '0' at the other end.
- (ii) Relay Contacts.** Clean the contacts of both relays and check the action by operating them manually.
- (iii) Dial Lights.** Check that these are tightly screwed in and replace any which are excessively discoloured.
- (iv) D.C. Control Plug.** Check that the pins are clean and undamaged and that the connector fits tightly.
- (v) R.F. Input Plug.** Examine for any signs of damage or corrosion.
- (vi) Check the action of the tuning controls and locks.** Where necessary tighten grub screws etc. and lubricate control shafts with Oil OM-13, but apply this sparingly and clean off any surplus with a dry rag.

(c) Power Supply Unit

- (i) **Rotary Transformer Brushes.** Remove each brush in turn and carefully clean with a dry rag; report any sign of excessive pitting or burning. Replace all sound brushes exactly as they were withdrawn, but fit a new brush if the old one is worn down to less than 1/8 inch.
- (ii) **Relays.** Clean the contacts of both relays and check the action by operating them manually.
- (iii) **Valves.** Check that both valves are firmly seated and securely held by the retainers.
- (iv) **Vibrator.** Make sure that this is plugged right in.
- (v) **On/Off Switch.** Inspect the fixed contacts and the moving rollers and report any signs of burning or pitting.
- (vi) **Fuses.** Check that these are of the correct rating.
- (vii) **Plugs and Sockets.** Lightly grease the coarse outer threads of the Battery Input plug and the Power Output socket and see that all plugs and sockets are undamaged.
- (viii) **Components and Wiring.** Inspect all components and wiring (particularly below the chassis) and report any signs of over-heating, burning or other damage. Clean out all dust, etc., but be careful not to move any components or wire into a position in which there may be a short circuit.

(d) Wireless Set

- (i) **Slow Motion Drives.** Lubricate where required with Oil OM-13, but do not apply more than is necessary and clean off any surplus with a dry rag.
- (ii) **Relays.** Clean the contacts of both relays and check the action by operating them manually (access to the contacts of the Aerial Coupling control change-over relay is through the hole in the end of the chassis).
- (iii) **Control Shafts.** Lightly lubricate where necessary, using Oil OM-13, but do not apply more than is necessary and clean off any surplus with a dry rag.
- (iv) **Valves.** Ensure that all retaining cans are in position but do not remove the valves without reason. Check that the sender P.A. and Modulator valves are securely held by the retainers and that the top cap connections are tight.

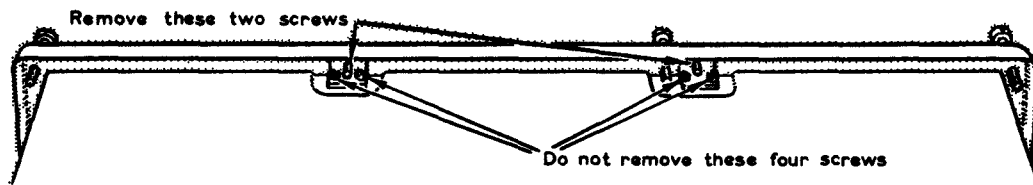

Fig 14

- (v) **Dial Lights.** Check that these are tightly screwed in and replace any that are excessively discoloured.
- (vi) **Components and Wiring.** Remove the bottom cover from the chassis, taking care not to remove the fixing screws from the two brackets illustrated in Fig. 14. Inspect all components and wiring, particularly below the chassis, but be very careful not to disturb any wires or components as this may upset the calibration or impair the performance. Report any signs of overheating, burning or other damage. Replace the bottom cover and clean off any dirt or dust from the top of the chassis.
- (vii) **Plugs and Sockets.** Lightly grease the coarse outer threads of the Power Input plug and the Harness socket and see that all plugs and sockets are clean and undamaged.

### (3) Functional Test and Fault Location Procedure

This procedure has been arranged in the same sequence as that given for the Operator in Sec.19(2), but the scope has been broadened to include the extra work which the R. Signals mechanic is equipped to perform.

**WARNING: THE POWER MUST BE SWITCHED OFF BEFORE CHANGING VALVES OR MAKING INTERNAL ADJUSTMENTS.**

#### (a) Check Battery Supply

Switch on and check that both vibrator and pilot lamp are working.

##### *Neither Operate:*

- Check the D.C. supply at the Battery Input plug and trace back to the fault with the Avometer.
- Check On/Off switch.

##### *Vibrator Does Not Start:*

- Check L.T. fuse.
- Try replacement vibrator.

(b) Check L.T. Supply to the Set Unit

Switch the Stand-By switch to Rec. Trans. & I.C., the System switch to Voice and the Meter switch to L.T. Note the voltage. This, after allowing for any meter error recorded on the front panel, should be greater than 10.5 V.

**No Meter Indication:**

- Remove Connectors 12 pt No.85 and check for continuity through leads G and D.
- Check for L.T. across pins G and D of the P.S.U. Power Output socket.

(c) Check Voltage Control Relay

Remove the plug from the Harness socket of the set unit; check that the voltage control relay in the P.S.U. is heard to release and that the L.T. voltage decreases slightly (but see note).

**Voltage Control Relay Does Not Release:**

- Remove the plug from the Harness socket of the set, earth socket K, and check whether this operates the relay.

**Relay Operates:**

- Check for continuity from pin K to pin G of the plug (When Control Harness A or B is in use this continuity is provided by the contacts of the voltage control relay in the harness. In other cases it is provided by a permanent connection in the W.S. C12 connector).
- Where the installation is not equipped with Control Harness A or B check also for continuity from pin G to the metal housing of the plug.

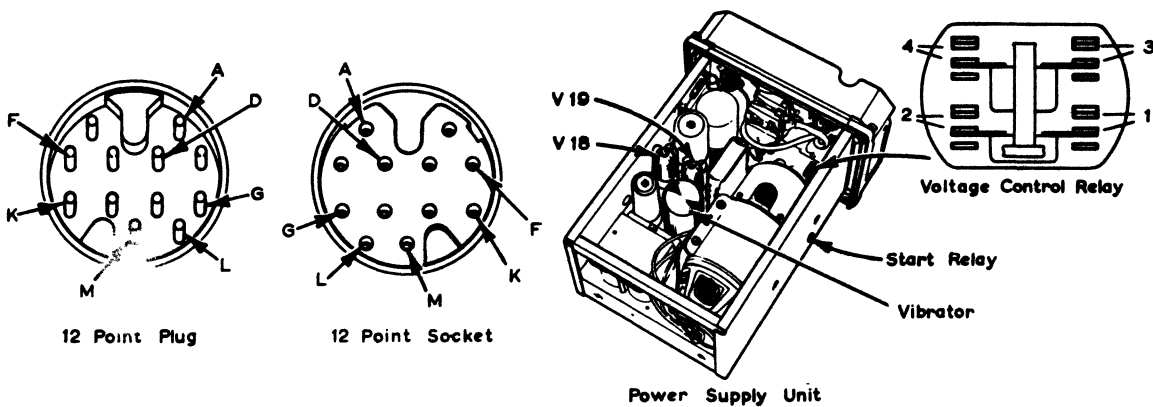

**Relay does not operate:**

- Remove Connectors 12 pt No.85 and check continuity through lead K.
- Earth socket K of the P.S.U. Power Output socket.
- Check action of relay manually.

**Relay Operates But Voltage Does Not Fall:**

- Clean contacts.

Note. When using Control Harness A or B the Voltage Control Relay will not be affected by removing or inserting the Harness plug unless the battery voltage is below 12.75 V. Therefore the battery must not be on float charge when this test is carried out.

**(d) Check H.T.1 Supply**

Replace the Harness plug, switch the Meter switch to H.T.1 and note the voltage. If the true L.T. voltage is 12 V. the H.T.1 voltage should be between 230 and 270 volts, but otherwise it will vary by about 20 volts (just over one division of the meter scale) for every one volt change in L.T. (two meter scale divisions).

**No H.T.1 Indication:**

- Check H.T.1 fuse.
- Remove Connectors 12 pt No.85 and check continuity through lead F.
- Check for H.T.1 voltage at socket F of the P.S.U. Power Output socket.

**H.T.1 Indication Low:**

- Replace P.S.U. rectifier valves (V18 and V19) in turn.
- Replace vibrator.

**(e) Check Operation of Rotary Transformer**

Switch the System switch to C.W. and check that the rotary transformer starts.

**Rotary Transformer Does Not Start:**

- Move System switch from C.W. to Net once or twice and check whether Start relay in P.S.U. can be heard to operate.

**Start Relay Does Not Operate:**

- Check continuity of leads A L and M in Connectors 12 pt. No. 85.
- Check for continuity at Power Input plug on set unit:
  - pin M to pin L ..... (Checks Stand-By switch)
  - pin A to chassis ... (Checks System switch)

- Check for the following at the P.S.U. Power Output socket:  
     socket M to chassis ..... L.T. voltage  
     socket L to socket A .... continuity through Start relay coil.
- Check Start relay manually.

**Start Relay Operates:**

- Clean contacts of Start relay.
- Check L.T. brushes of rotary transformer.

**(f) Check Operation of Microphone Pressel Switch**

Switch the System switch to Voice and the control harness (where used) to the 'A' set position. Press the microphone pressel switch and check that the rotary transformer starts.

**Rotary Transformer Does Not Start:**

- Press microphone pressel switch and check whether Send/Receive relay can be heard to operate.

**Send/Receive relay operates:**

- Clean contact 1 of Send/Receive relay.

**Send/Receive relay does not operate:**

- Remove plug from Harness socket (set unit) and earth socket D.

**Relay now operates:**

- Press microphone pressel and check continuity from D to G of the plug.

**Relay still does not operate:**

- Check continuity through lead H of Connectors 12 pt. No: 85.
- Check continuity between H and L of P.S.U. Power Output socket.

**(g) Check H.T.2 Supply**

Switch the Meter switch to H.T.2, press the microphone pressel switch and note the H.T.2 voltage. If the true L.T. voltage is 12V. the H.T.2 voltage should be between 370V. and 430V. but otherwise it will vary by about 33V. for every one volt change of L.T.

**No H.T.2 Voltage:**

- Check H.T.2 fuse.
- Check continuity of lead B of Connectors 12 pt. No. 85.
- Check for H.T.2 at socket B of P.S.U. Power Output socket:
- Examine H.T. brushes on rotary transformer.

**H.T.2 Voltage low:**

- Examine all brushes, especially L.T. brushes.

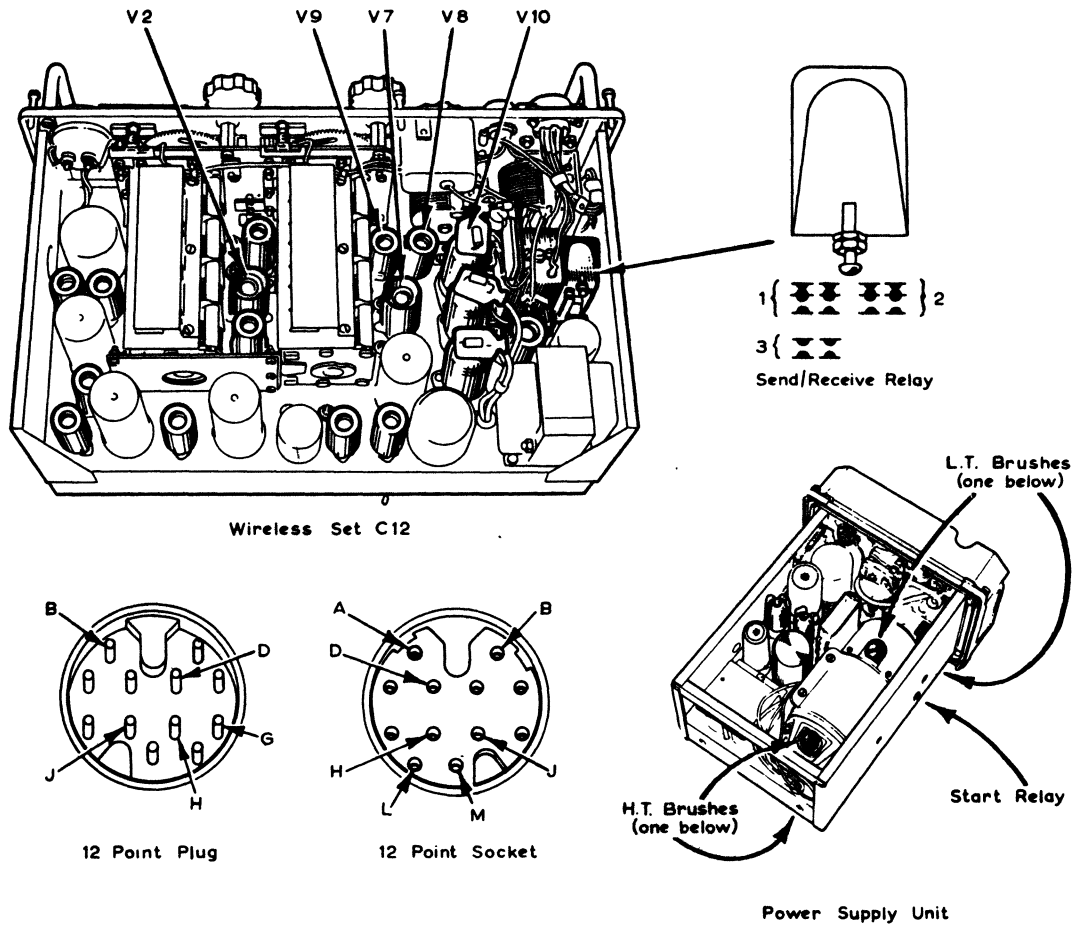

(h) Check Sender Drive

Switch the Meter switch to Drive and the Flick switch to 'A-1.6/4.0 Mc/s'. Press the microphone pressel switch and check that the set meter indicates at least 100 V. (2.5 V. on the upper scale). Repeat the same test on the remaining three positions of the Flick switch.

**No Drive or Low Drive:**

- Check valve heaters as in para. (s).
- Clean contact 2 of Send/Receive relay.
- Check continuity through lead J of Connectors 12 pt No.85.
- Check the following valves in turn by substitution:  
*V<sub>2</sub>, V<sub>7</sub>, V<sub>8</sub>, V<sub>9</sub> and V<sub>10</sub>. (If drive is correct in the 4.0/10.0 Mc/s positions but fails in the 1.6/4.0 Mc/s positions V<sub>8</sub> should be suspected).*

(i) Check Sender Alignment

With the Flick switch in either of the 1.6/4.0 Mc/s positions tune the Frequency control through the entire frequency range and check that the set meter indication does not fall below 100 V. at any setting. Repeat the test in either of the 4.0/10.0 Mc/s positions.

*If the set fails to meet this requirement it should be returned to workshops for re-alignment.*

(j) Check Earth Return from A.T.U. to Set Unit

Switch the Meter switch to Ae. Current and check that there is no indication on the set meter.

**Meter Indication Obtained:**

*-Switch the Meter switch to any other position and check Co-axial connector for continuity through the outer braiding.*

(k) Check Aerial Current

Switch the Meter switch to Ae. Current, the Flick switch to either of the 'A' positions and tune the transmitter. Check that normal aerial current indication is obtained on the set meter and that both the 'A' dial lamps light (one in the set and one in the A.T.U.). Switch to either of the 'B' positions and repeat the same checks.

**No Dial Lamps Working:**

*-Check for L.T. at the D.C. Control plug of the set unit ('A' freqs - pin 3; 'B' freqs - pin 2).  
-Check dial lamps and holders in set unit.*

**Dial Lamps Working In Set But Not In A.T.U:**

*-Check 3 point connector for continuity.  
-Check dial lamps and holders in A.T.U.*

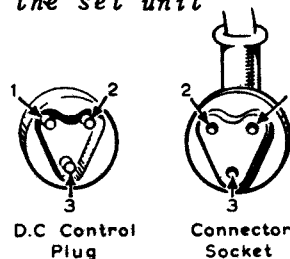

**All Dial Lamps Working But No Aerial Current:**

*-Check 3 point connector for continuity through lead 1.  
-Check coaxial connector for continuity.  
-With set switched on, and all connectors in position, check for insulation between A.T.U. Aerial and Earth terminals.  
If short-circuited disconnect aerial and re-check. If still short-circuited withdraw A.T.U. and check operation of relays.  
-Check top cap connector of V10.  
-Clean contact 3 of Send/Receive relay.  
-Check A.T.I. connections and clean wheel, shaft and end contact.  
-Change V10.*



**Aerial Coupling Control 'B' Not Operating:**

- Check operation of Aerial Coupling change-over relay (RLD) and clean contacts.

**(1) Check Sender Modulation**

With the transmitter tuned up press the microphone pressel switch and speak or whistle into the microphone. The indicated aerial current should fluctuate slightly and side-tone should be heard.

**No Fluctuation:**

- Remove connector from Harness Socket of set, press microphone pressel switch and check for continuity between sockets A and B of connector. There should be about 50 ohms resistance and slight clicks should be heard in the microphone. If not check through harness connections and headgear assembly.
- Check valves V11, V12 and V13 in turn by substitution.

**Fluctuation But No Side Tone:**

- Remove connector from Harness socket of set and check continuity between pins G and M of connector. There should be up to 100 ohms resistance depending on the number of headsets and clicks should be heard in each headset. If not check through harness connections and headgear assembly.
- Change V6.

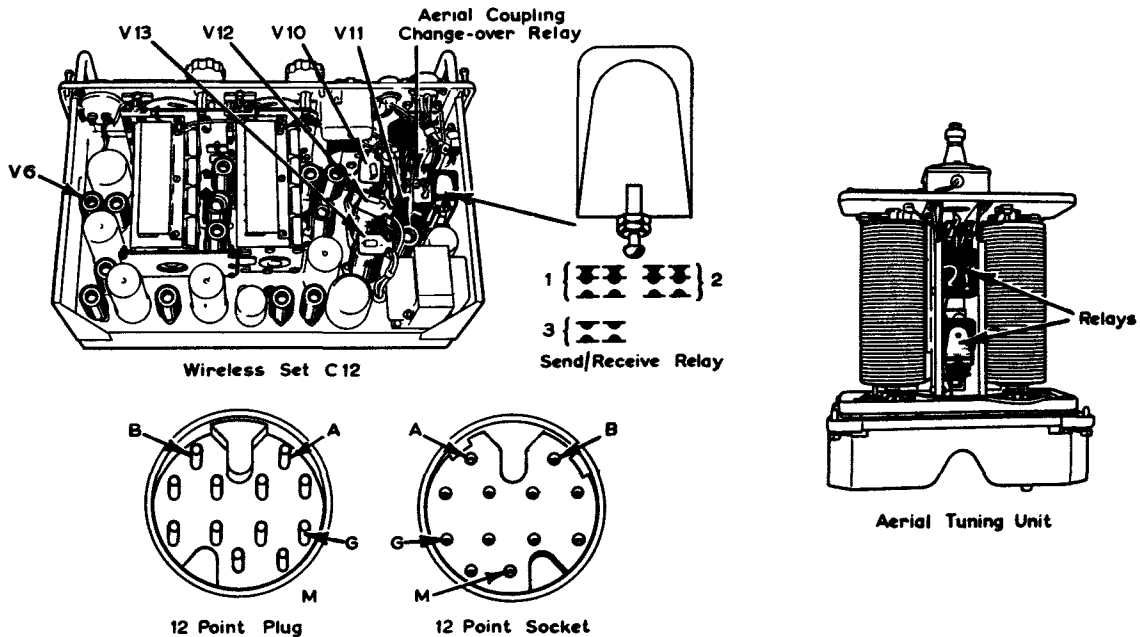

(m) Check Receiver B.F.O. and R.F. Gain Control

Switch the Meter switch to A.G.C. and check the meter readings with the Gain control fully clockwise and fully anti-clockwise. They should be about 6 V. and 1 V. respectively. Check also that the normal C.W. note can be obtained when signals are tuned in.

**No Meter Indication (or Abnormal Indication):**

- Clean contact 2 of Send/Receive relay.
- Change  $V_1$  and  $V_3$ .

**Correct Meter Indication but No Signal:**

- Change  $V_2$ ,  $V_4$ , and  $V_5$ .

(n) Check A.G.C. Action

Switch the System switch to Voice and check that, with no signal tuned in, the meter indicates about 8V. Check also that this indication is reduced in proportion to the strength of any station tuned in.

**Meter Does Not Dip On Signal:**

- Change  $V_5$ .

(o) Check B.F.O./I.F. Alignment

Switch the System switch to Net and tune the set to zero beat on any strong station. Switch to Voice and check that it is not possible to improve the tuning by means of the Frequency control.

*If any improvement can be obtained the set is out of alignment and the fact should be reported.*

(p) Check Het. Tone Control

With the set tuned for zero beat as in para. (o) switch to C.W. and check that a satisfactory variation in the beat note can be obtained by means of the Het. Tone control. Check also that the beat note is again reduced to zero when the pointer of this control is approximately central.

**Het. Tone Control Inoperative:**

- Clean contact 1 of Send/Receive relay.

**Het. Tone control appreciably off centre for zero beat:**

- Re-tune the set on Net and repeat the check. If the error is still present, report.

(q) Check I.C. Facilities

Switch all control units to I.C. and check all headsets for speaking and listening and for speech and buzzer from driver.

*I.C. Not Operating:*

- Remove the plug from the Harness socket of the set unit, press any microphone pressel switch, and check the microphone circuit for continuity between pins B and C of the plug. The resistance measured should be about 50 ohms and faint clicks should be heard in the microphone.
- Check the headphone circuit between pins G and J of the plug. The resistance in this case will be up to 100 ohms depending on the number of headsets, but faint clicks should be heard in each headset.
- Change V14 and V15.

*Driver's Speech and/or Buzzer Inoperative:*

- Check wiring from 2-point terminal strip on Adaptors Connector 12 point No. 1 to driver's junction box.

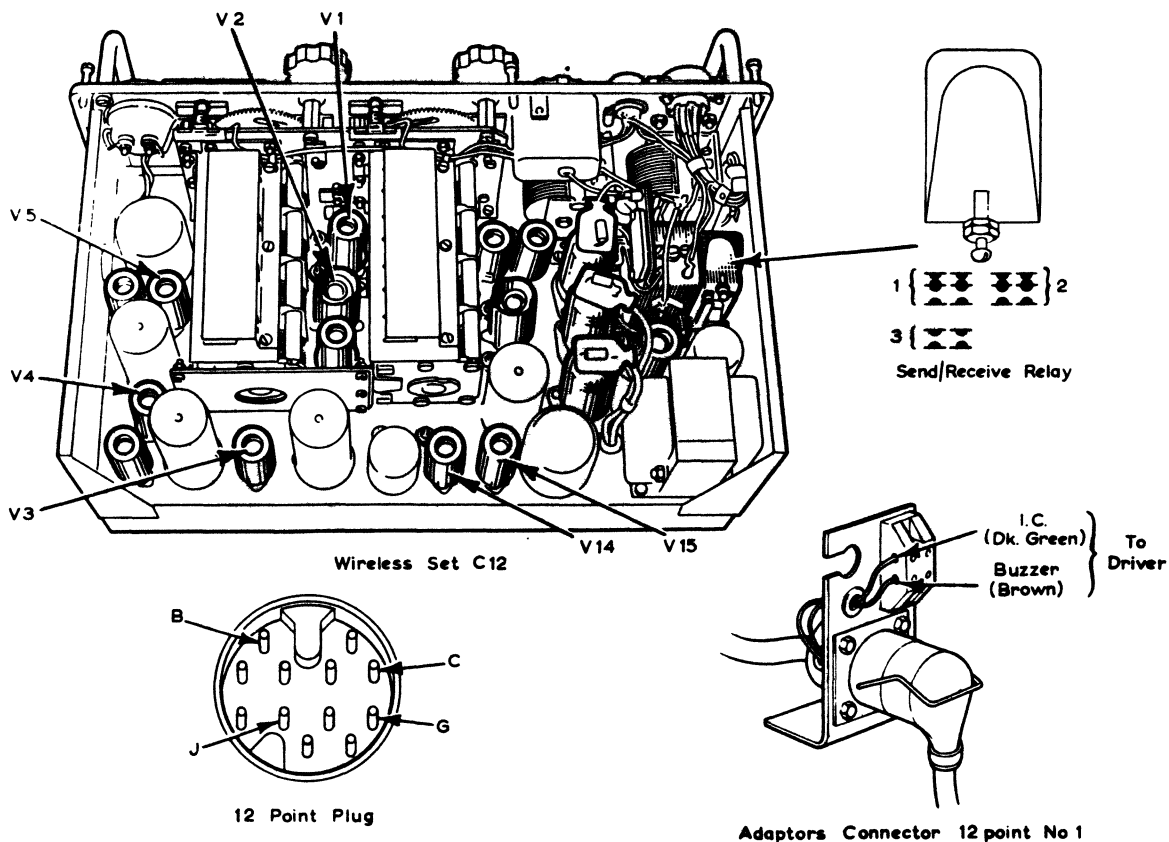

(r) Check 'A Set Un-attended' Lamp (19 set harness only)

Switch all control units to 'B' (or 38/88) and check that the 'A set un-attended' lamp lights.

*Lamp Not Lighting:*

*-Remove plug from HARNESS socket and check that 12V. is present at pin F. If it is the fault is either in the bulb or the 19 set harness.*

(s) Check Valve Heater Circuits

This check need be made only when a fault occurs which is attributable to valve failure; in this event, before any valve is changed, all valves should be examined to verify that the heaters are working.

To do this the chassis must be withdrawn far enough to permit each valve to be inspected whilst the set is switched on (the P.S.U. will have to be withdrawn a little way to allow this). There will be nothing visible in V16 or V17, but in all other valves the glow from the heater should be detectable somewhere in the glass envelope, if not through the pip at the top. Occasionally it may be seen reflected from the inside of the valve can, and an additional check is to feel whether the envelope is warm to the touch.

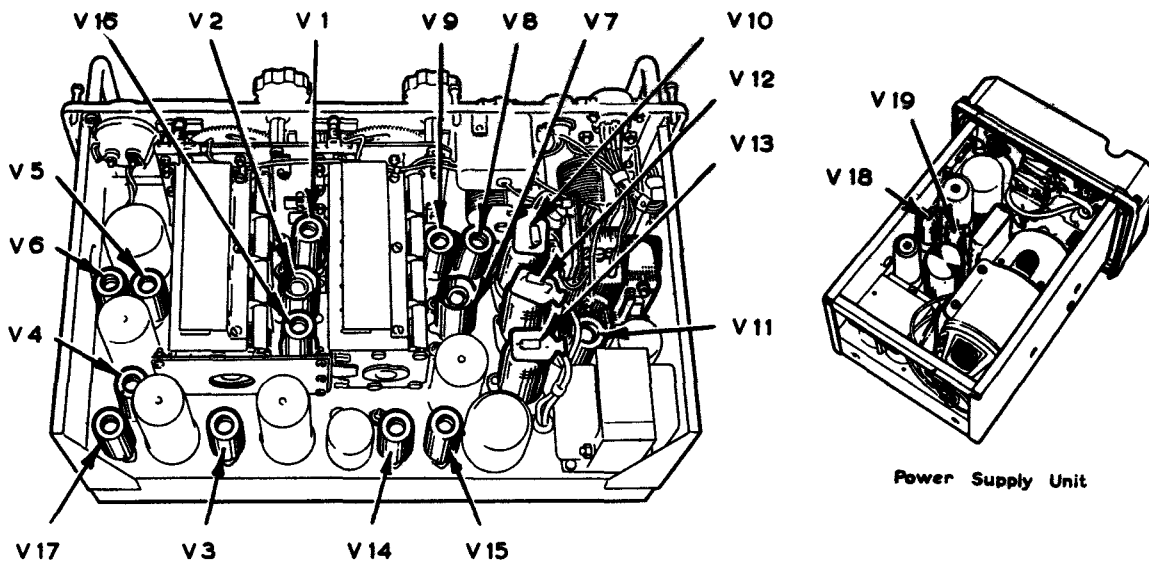

Wireless Set C12

Power Supply Unit

It must be remembered, however, that there are two distinct heater circuits, as given in Fig. 13. The 'Receiver' circuit includes all valves required for receiving, although some of them are also used for sending. All other valves are in the 'Sender' circuit, which is only in operation when the Stand-By switch is at Rec. Trans. & I.C. The supply to this circuit is via socket C of the P.S.U. Power Output Socket; if the entire circuit appears to be out of action check for L.T. at this point and also check continuity through lead C of Connectors 12 pt No.85.

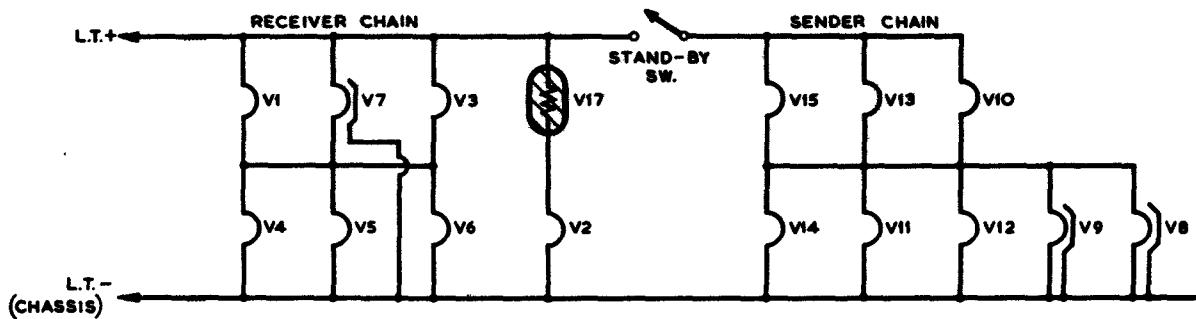
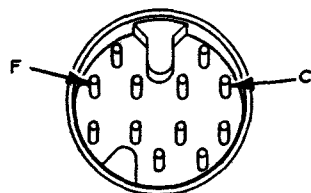

Fig 13

Heater Circuits

In the case of V7 (Receiver circuit) and V8-9 (Sender circuit) the cathode of the valve is connected direct to chassis, and an internal short circuit from cathode to heater can thus affect the whole heater circuit, depending on which end of the heater is affected. If it is found that some valves are not glowing whilst others are glowing too brightly either V7 or V8-9 should be checked by substitution to begin with. If this fails to clear the fault reference to Fig. 13 will simplify further investigation.



12 Point Plug

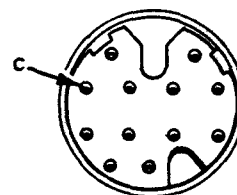

12 Point Socket

APPENDIX A

Valves, Relays, etc:- Set Unit

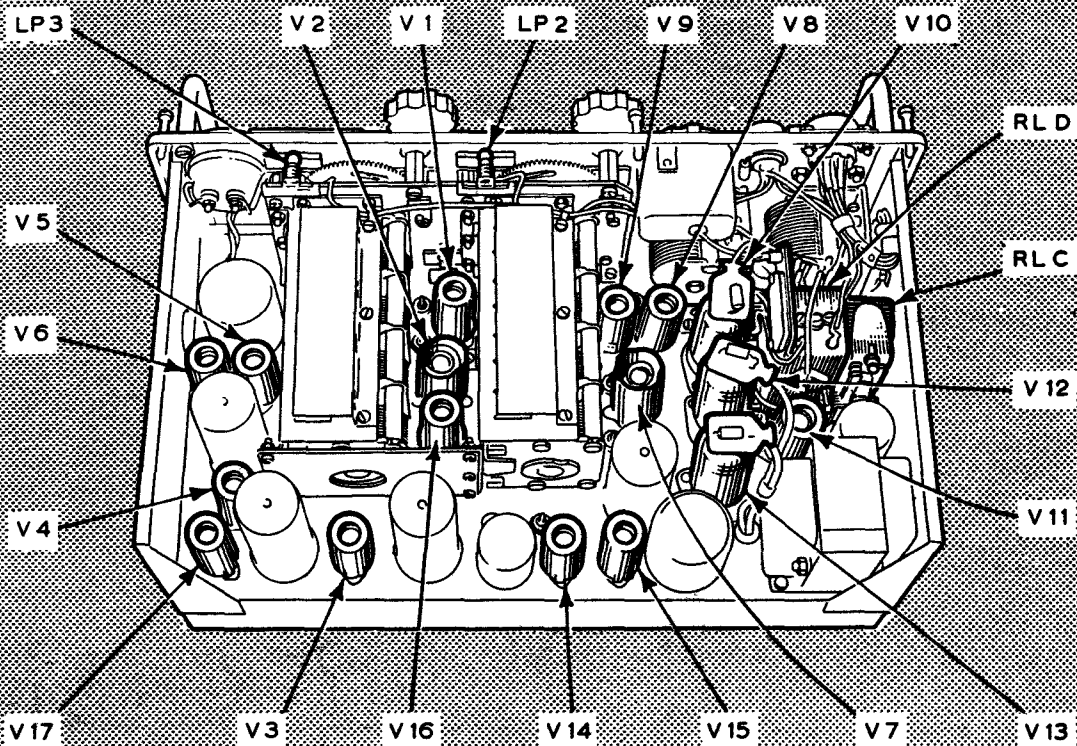

SET UNIT

Circuit Ref.	Catalogue No.	Function
V1	CV 131	Receiver R.F. Amplifier.
V2	CV 2128	" Frequency Changer.
V3	CV 131	" 1st I.F. Amplifier.
V4	CV 131	" 2nd I.F. Amplifier.
V5	CV 452	" Detector, A.G.C. and Audio Amplifier.
V6	CV 136	" Audio Output & Sender Side-tone Amp.
V7	CV 2128	Sender Frequency Changer.
V8	CV 138	" Buffer/Amplifier - All Frequencies.
V9	CV 138	" " " - 1.6/4.0 Mc/s only.
V10	CV 428	" Power Amplifier.
V11	CV 492	" Speech Amplifier.
V12	CV 428	" Modulators.
V13	CV 428)	
V14	CV 131	I.C. Amplifier - 1st Stage.
V15	CV 136	" " - 2nd Stage.
V16	CV 287	Voltage Regulator for V.2.
V17	CV 2293	Barretter for V2 Heater Supply.
RLC		Send/Receive Relay.
RLD		Aerial Coupling Condenser Change-over Relay.
LP2	X951902	Dial Lamp - Frequency 'A'.
LP3	X951902	" " - Frequency 'B'.

Valves, Relays, etc:- P.S.U. and A.T.U.

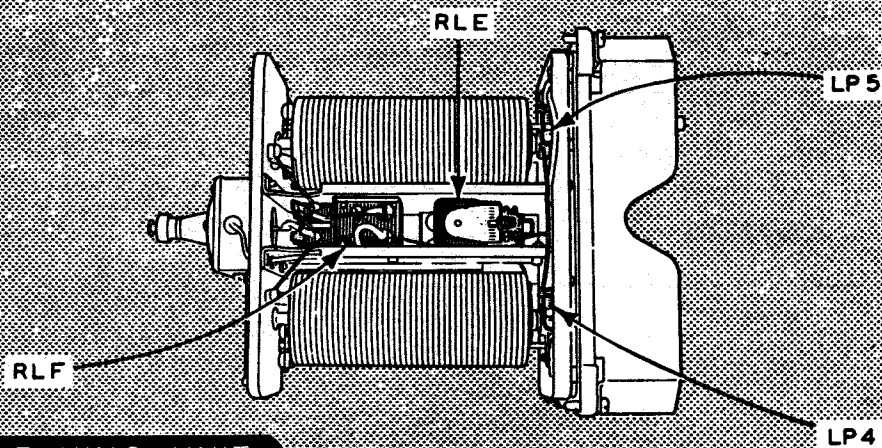

**AERIAL TUNING UNIT**

Circuit Ref.	Catalogue No.	Function
RLE		Change-over Relay energised on Freq. 'B'.
RLF		" " " " " " Freq. 'A'.
LP4	X951902	Dial Lamp - Freq. 'A'.
LP5	X951902	" " - Freq. 'B'.

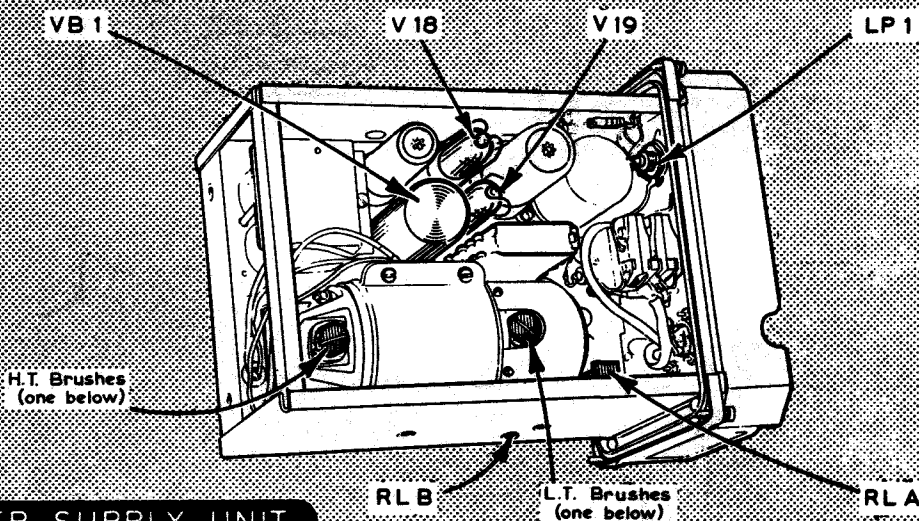

**POWER SUPPLY UNIT**

Circuit Ref.	Catalogue No.	Function
V18	CV 493 )	Rectifier Valves-H. T. 1.
V19	CV 493 )	
VB1	ZA 45420 or ZA 45421	H. T. 1 Vibrator (12 V.). " " (24 V.).
RLA		Voltage Control Relay.
RLB		H. T. 2 Start Relay.
LP1	X951219	Pilot Lamp.

APPENDIX C

Power Supply and Control Circuits.

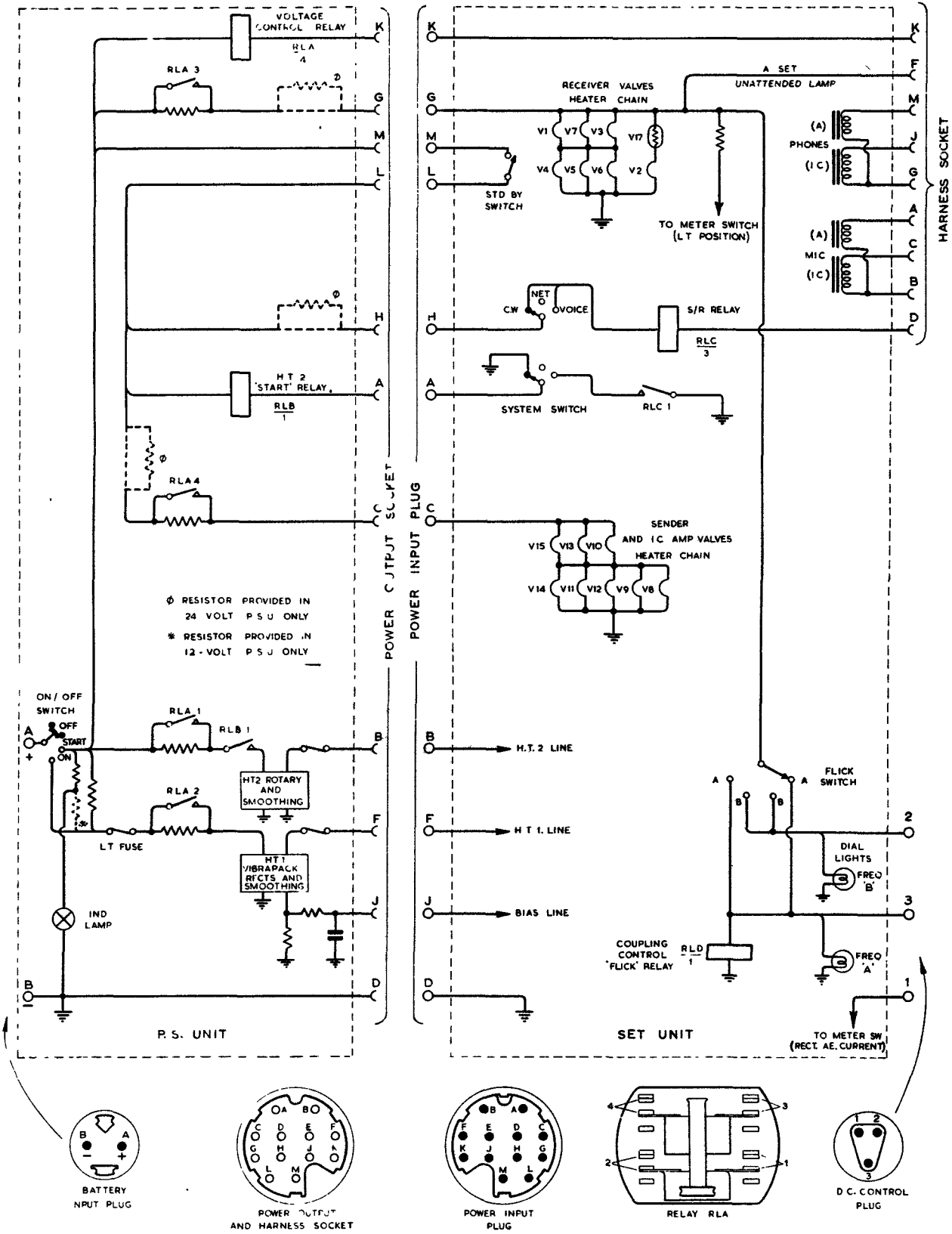



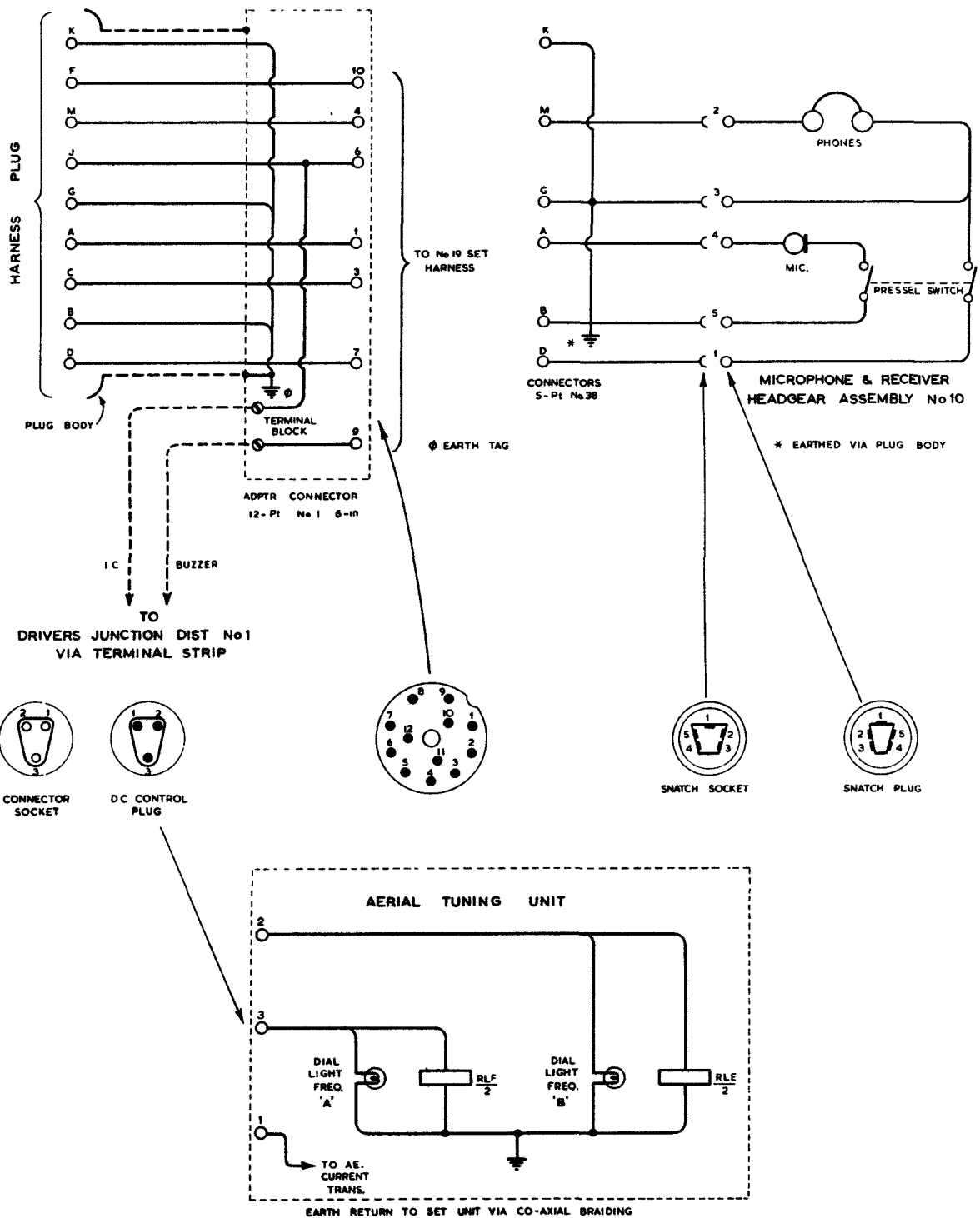







# IDEAS SUGGESTIONS DEFECTS

**YOU are the user of this equipment – can it be improved?**

If you have any good suggestions about this or ANY Signals equipment, The Ministry of Defence Army Department are interested.

## ***Ideas and Suggestions***

If you can suggest:

- (a) an improvement in design or shape,***
- (b) a better method of installation, operating, or servicing,***
- (c) other equipments which might do the job better,***

the procedure is quite simple – pass it to your OC or Adjutant for transmission to the local Chief Signal Officer.

It will remain YOUR idea.

See the Signal Equipment Performance Report (AF B63), details for completion of which are found on the cover of the pad.

## ***Defects***

If there is something wrong with the equipment AS IT STANDS, other than a fair wear and tear fault, it is a defect.

Again, don't keep it to yourself, pass it to your OC. The procedure for him to follow is given in EMER Management N200. (AFG 3660 is the form to use).

