

RESTRICTED

The Information given in this document
is not to be communicated either directly
or indirectly, to the press or to any person
not authorized to receive it

**USER HANDBOOK
FOR
CHARGING SETS 60 - W, 12 - V,
PEDAL DRIVEN, NO.2. Mk.1.**

1953

Provisional Edition

*Prepared and Printed by
Ministry of Supply Inspectorate of Electrical and Mechanical Equipment
Aquila', Golf Road Bromley Kent
(Nearest Station Chislehurst)*

IMPROVEMENT OF SIGNAL EQUIPMENT

Do you think YOU can improve ANY Signals Equipment?

Can you suggest:

- (a) An improvement in design or shape?
- (b) A better method of installation, operating or maintenance including the tools you use?
- (c) Other equipments which might do the job better?

The War Office is interested in your ideas. Apply to your Troop Commander for details of the method whereby suggestions may be passed by YOU to the War Office.

War Office Memorandum to C.S.Os, reference 42540 (Signals 3(c)) dated 30th March 1948 refers.

Suggestions from Other Arms of the Service will be welcomed but should be passed to the nearest Chief Signal Officer.

RESTRICTED

USER HANDBOOK
FOR
CHARGING SETS 60 - W, 12 - V,
PEDAL DRIVEN, NO.2. Mk.1.

CONTENTS

	Page
GENERAL DESCRIPTION	2 - 6
ERECTION	7 - 11
METHOD OF CONNECTING	12
OPERATION	13
DISMANTLING	14, 15
MAINTENANCE	16

GENERAL DESCRIPTION

1. PURPOSE. The Charging Set, Pedal Driven, 60 Watt, No.2, is a lightweight portable (Man Pack) charging set designed for charging one 12 Volt or two series connected 6 Volt portable secondary batteries at an average rate of 3.5 Amps.

Suppressors are fitted and the set may be used to charge batteries connected to a working wireless set, i.e. float charge, without undue interference.

The set may be erected for either Pedal or Hand operation as shown in figs. 1 and 2.

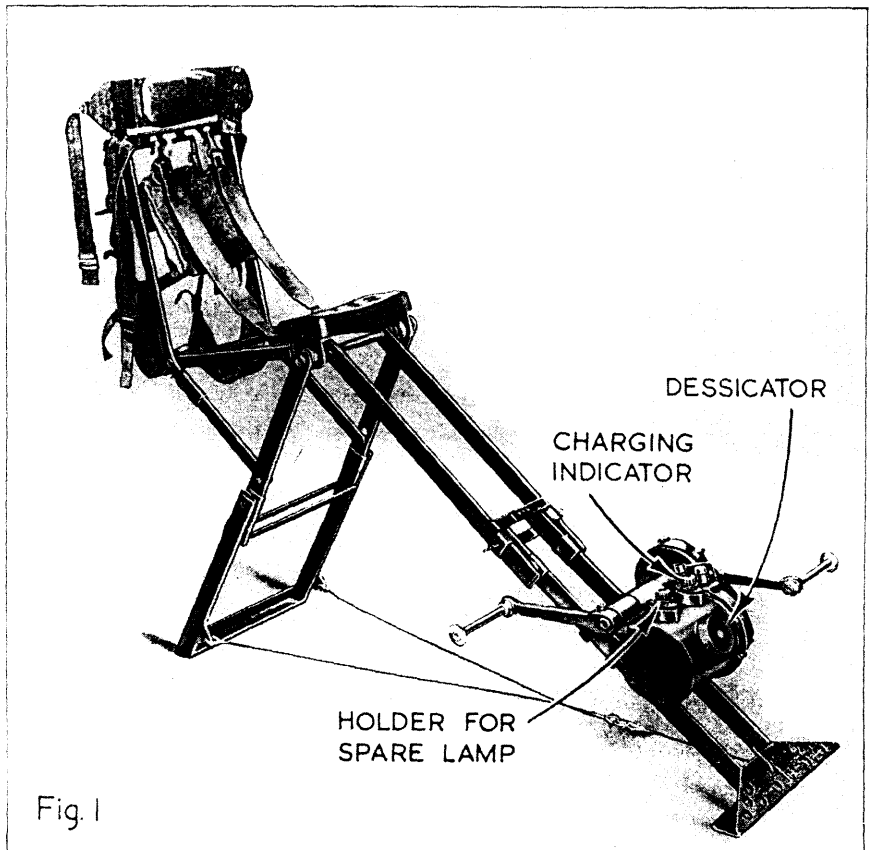

2. CARRIAGE. The complete set forms a man pack load complete with carrying harness, weighs approximately 31 lbs. and is carried as shown in figs. 3 and 4.

The harness is strapped to the body by means of the BREAST and WAIST straps which are fitted with quick release buckles. In an emergency is anticipated the waist strap should not be fastened, the load may then be removed quickly by pulling on the quick release tab of the breast strap.

The set consists of two frameworks, the generator frame on which the generator is mounted, and the seat frame to which the carrying harness is permanently attached.

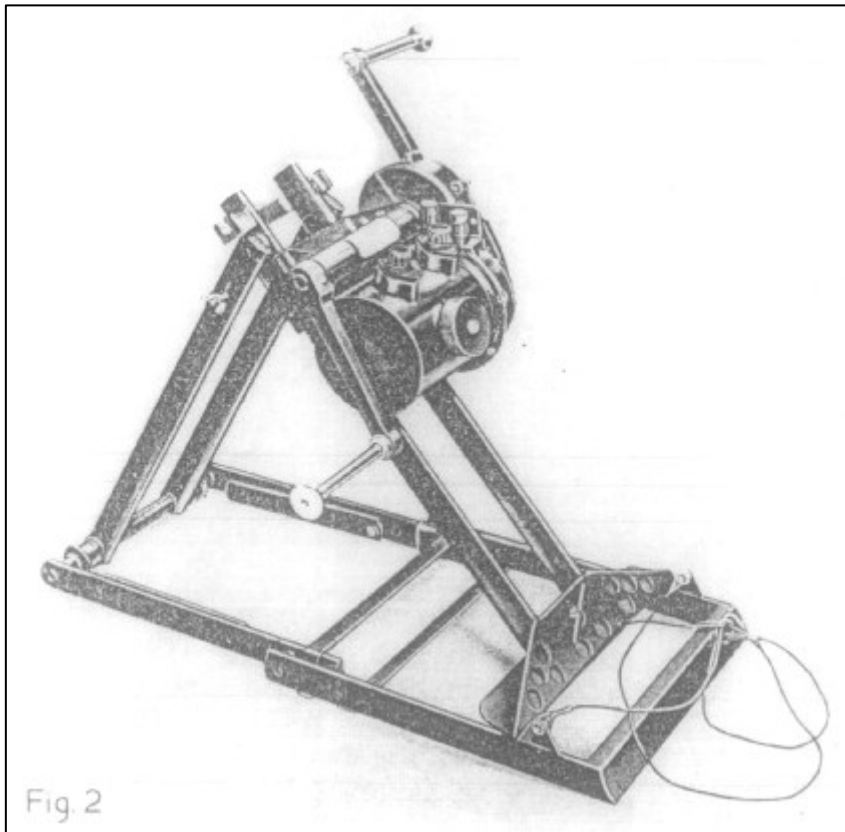

GENERAL DESCRIPTION

3. PERFORMANCE. The charging current is approximately 3.5 Amps. at the normal pedalling speed of 60 r.p.m., and increases with speed to 5 Amps. at 66 r.p.m.

4. CHARGING INDICATOR. A lamp indicator fitted to the generator case and visible to the operator, lights when the charging current reaches approximately 2.5 Amps. and becomes brighter for increasing values of charging current. The lamp is of the standard 2.5 Volt torch bulb type, an immediate spare is carried in a holder fitted to the generator case.



GENERAL DESCRIPTION

The charging set will function without the indicator lamp but a check should be kept on speed since without a charging indicator it is difficult to determine whether useful work is being done.

5. CUT OUT. An automatic cut out prevents the battery discharging through the generator when the output voltage is less than that of the battery.

6. DESSICATOR. The generator is tropically sealed and fitted with a dessicator to keep the interior dry.

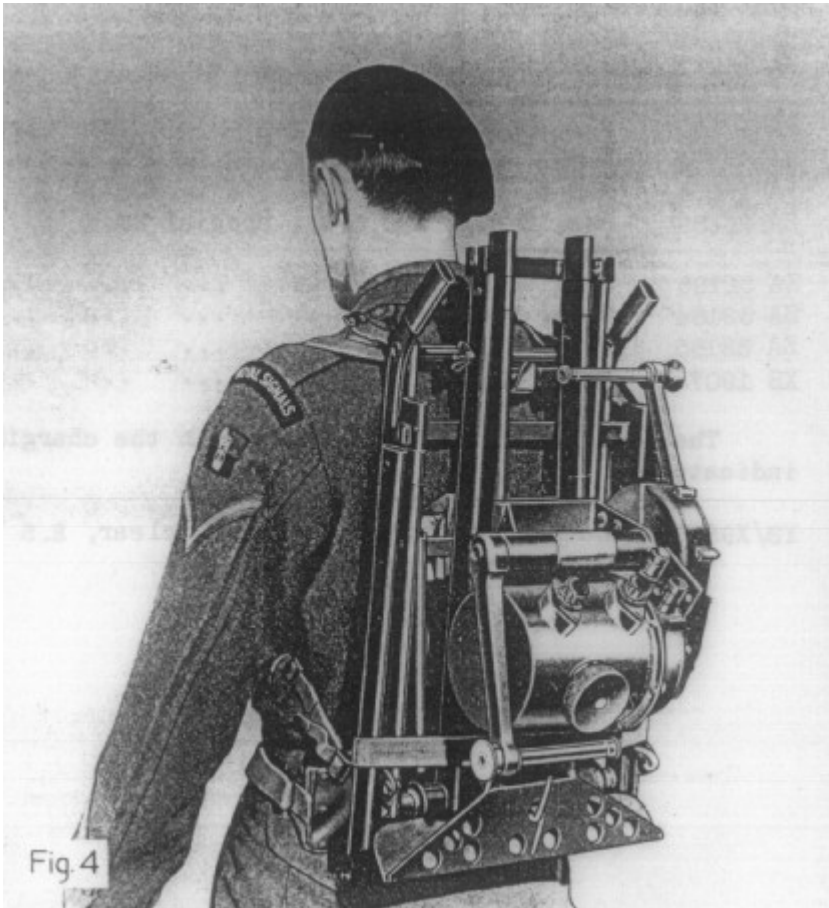

GENERAL DESCRIPTION

7. CONNECTORS. Connectors are provided for the connection of batteries with or without fitted sockets and for connecting two 6 Volt batteries together.

To assist identification at night the positive leads are longer than the negative and the positive generator terminal, raised higher than the negative, has a raised + on its upper face.

The connectors and tools, listed below, are carried in a Satchels Signals, No.7, strapped to the seat frame.

FA 16771	Screwdrivers, electricians, 3 in	1
	Spanners,					
FA 17190	B.A. Open jaw, D.E. 4-5	1
FA 17233	B.S.W. Open jaw, D.E. 1/8 in x 3/16 in					1
FA 17234	B.S.W. Open jaw, D.E. 1/4 in x 5/16 in					1
ZA 26289	Box, 2 B.A. x O.B.A., special No.1					1
	Connectors,					
ZA 32186	Single, No.157	1
ZA 32184	Twin, No.317	1
ZA 32185	Twin, No.318	1
XB 19075	Twin, 6 ft.	1

The designation of the lamp used in the charging indicator is:

Y3/X951129	Lamps, filament, Vac, MESC, clear, 2.5 V, 0.75 W.
------------	---

ERECTION

Place the pack load on the ground, generator uppermost. Unfasten the securing strap and separate the two frames.

To erect, for either Pedal or Hand Operation, proceed as follows.

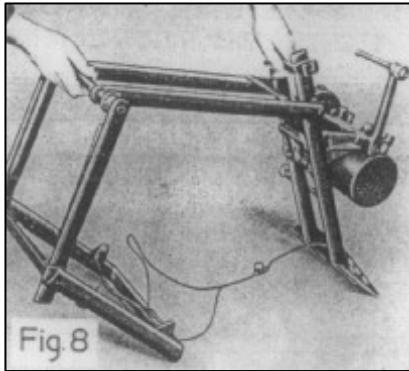
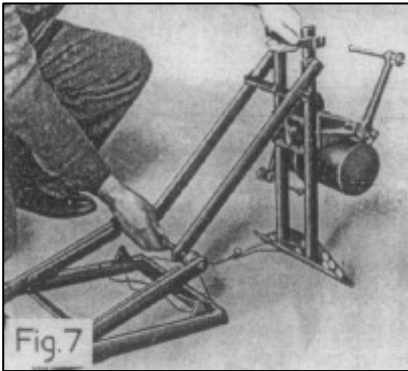
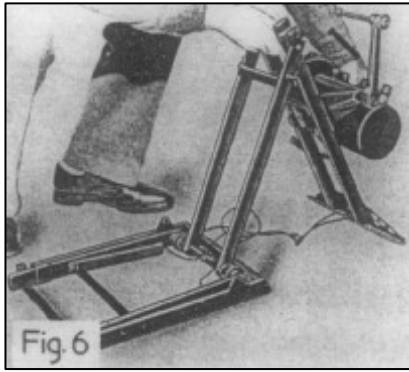
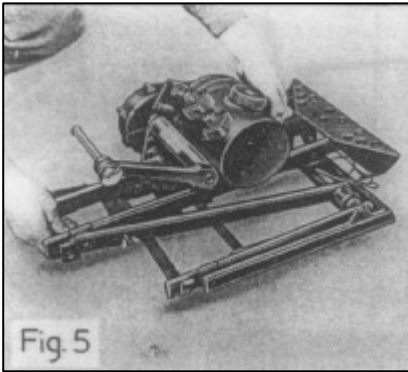

OPEN THE GENERATOR FRAME AS IN FIGS. 5-8.

FOR PEDAL GENERATOR CONTINUE OVERLEAF.
FOR HAND GENERATOR TURN TO PAGE 11.

ERECTION - PEDAL

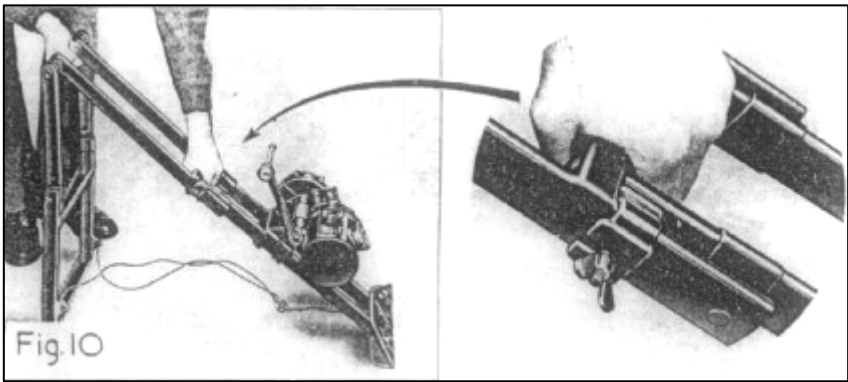
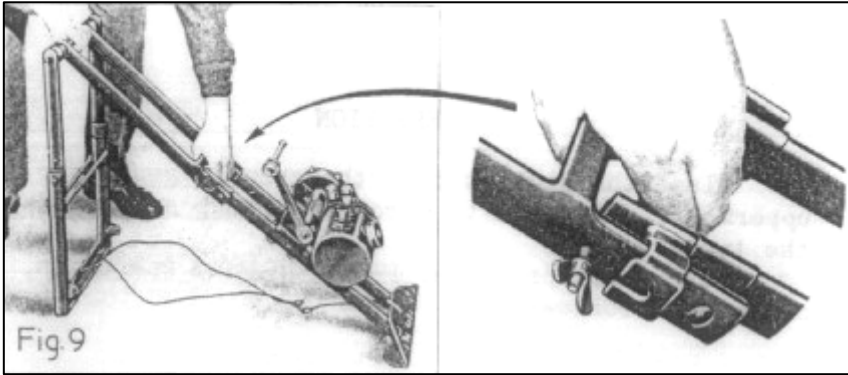

LOCK THE FRONT SECTIONS AS IN FIGS. 9 and 10.
TIGHTEN THE BUTTERFLY NUTS.

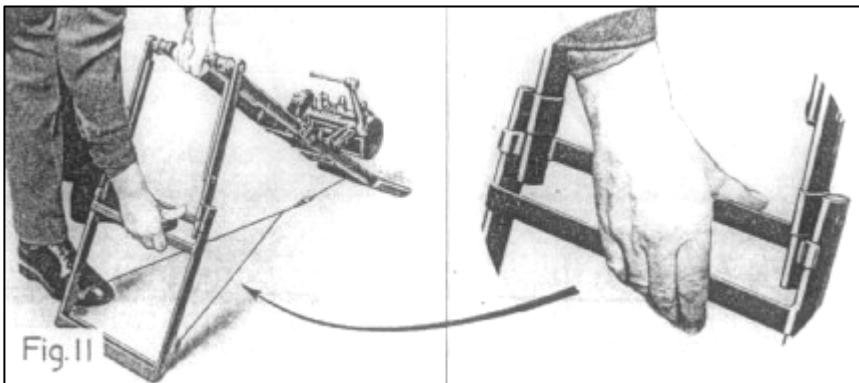

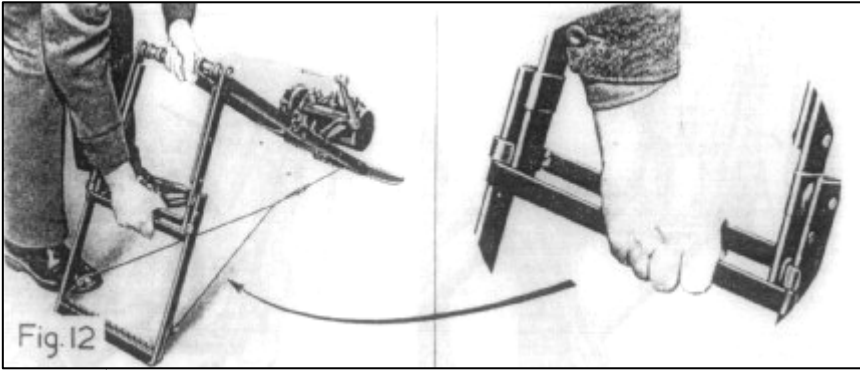

LOCK THE REAR SECTIONS AS IN FIGS. 11 and 12.

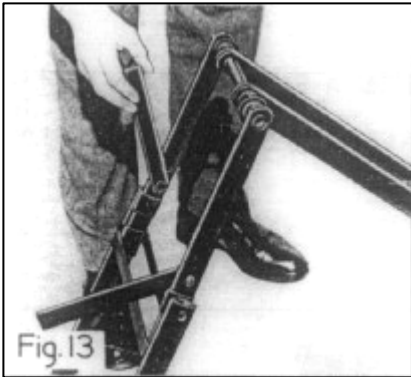

TURN THE SEAT FRAME SUPPORTS OUTWARDS

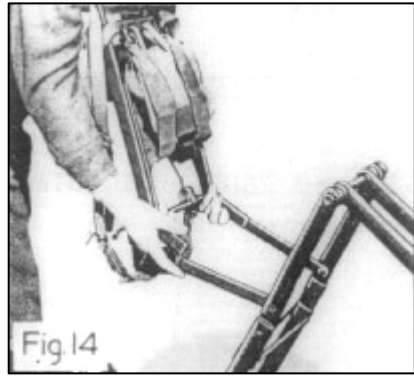

FIT THE SEAT FRAME

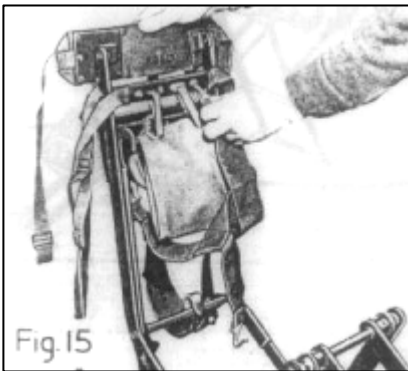

UNHOOK THE SEAT STRAPS

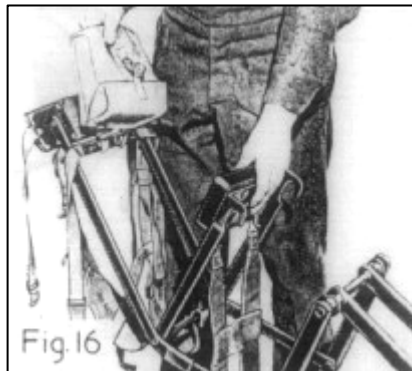

OPEN THE SEAT FRAME

ERECTION - PEDAL

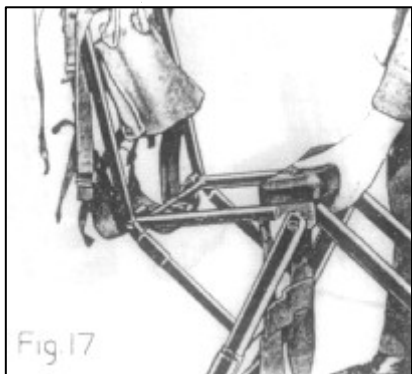

HOOK THE SEAT FRAME TO
GENERATOR FRAME

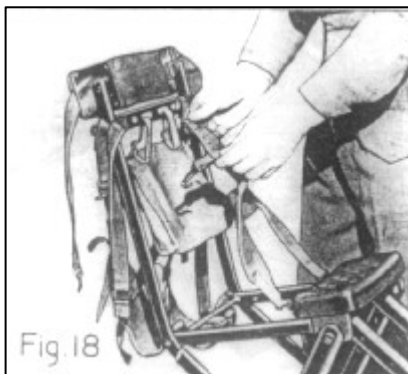

RE-HOOK THE SEAT STRAPS

TURN THE WAIST PAD OVER TO FORM A BACK REST

PUSH THE PEDAL BARS OUTWARDS

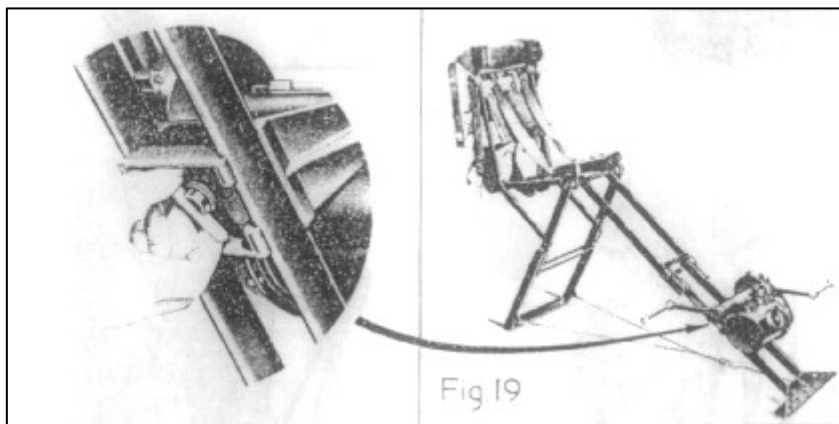

LOOSEN THE GENERATOR WING BOLT AS SHOWN IN FIG. 19,
MOVE THE GENERATOR TO A SUITABLE POSITION.
TIGHTEN WING BOLT.

ERECTION - HAND

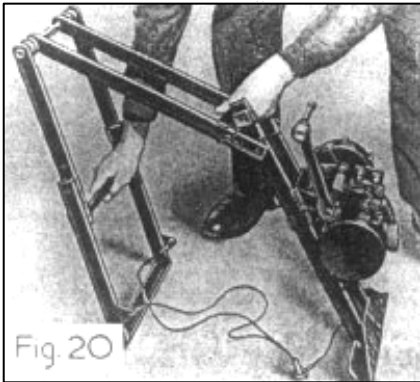

LOCK THE REAR SECTION

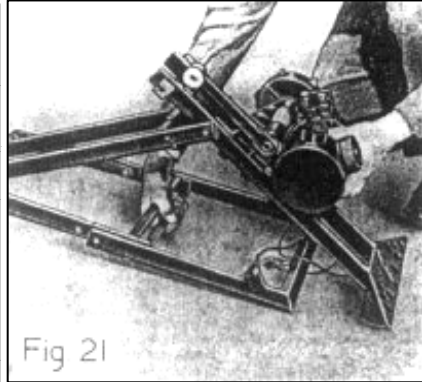

PLACE THE REAR SECTION ON GROUND TO FORM A BASE

LIFT THE FOOT OF THE GENERATOR FRAME ON TO THE BASE AND FIRMLY ENGAGE THE SLOTS IN THE FOOT WITH THE BASE LUGS AS SHOWN IN FIG. 22.

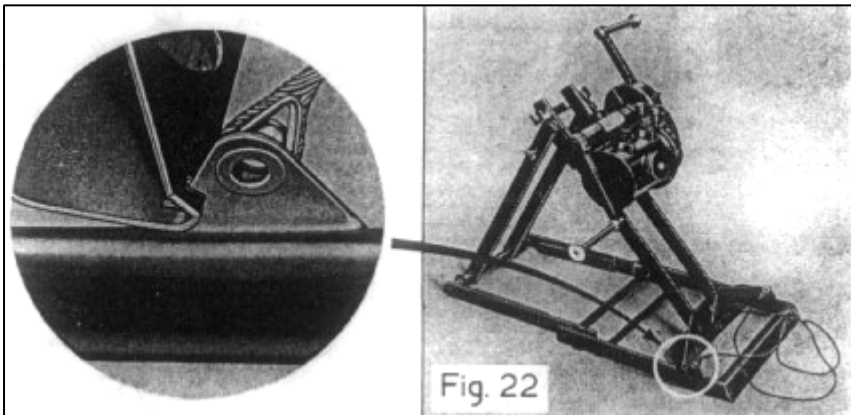

PUSH THE PEDAL BARS OUTWARDS.
LOOSEN THE GENERATOR WING BOLT AND RAISE THE GENERATOR TO THE TOP OF THE FRAME.
TIGHTEN WING BOLT.

METHODS OF CONNECTING

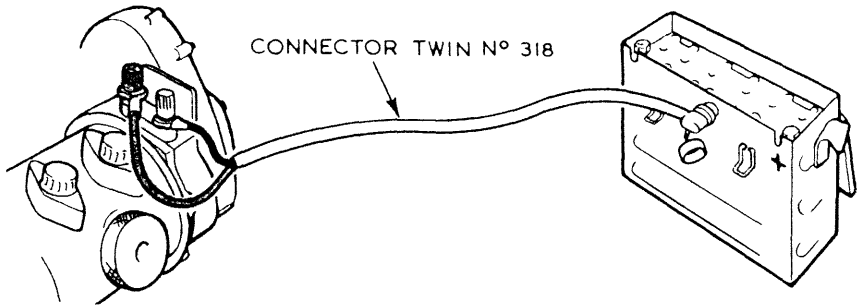

FIG. 23. CHARGING 12V BATTERY

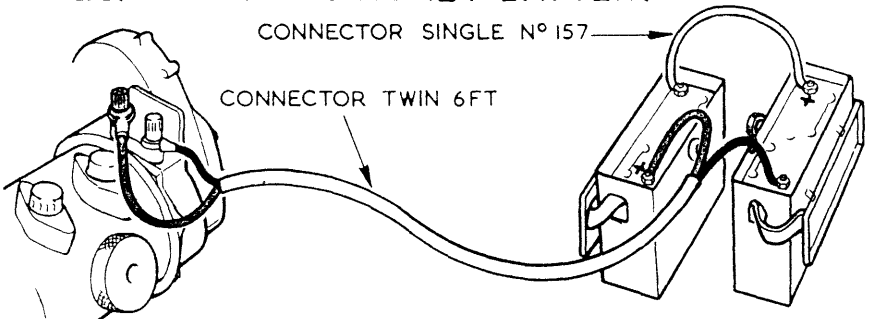

FIG. 24 CHARGING TWO 6V BATTERIES.

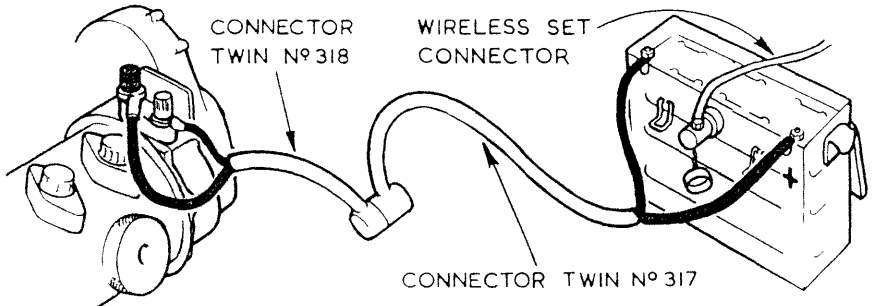

FIG 25. FLOAT CHARGING 12V BATTERY

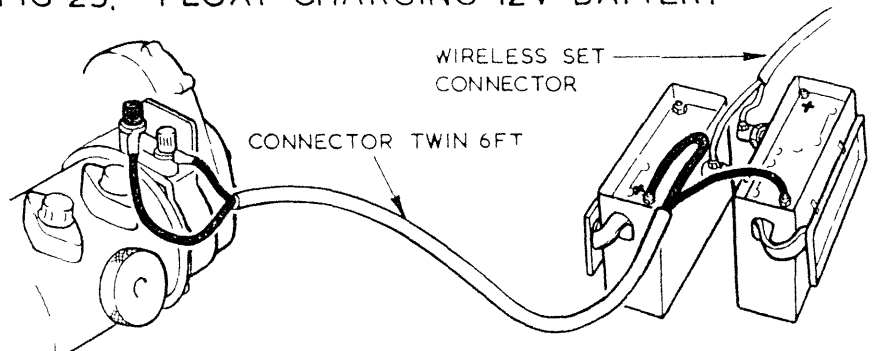

FIG 26 FLOAT CHARGING TWO 6V BATTERIES

OPERATING INSTRUCTIONS

1. Connect the lugs at one end of the appropriate twin connector (see figs.23-26) to the generator terminals, the longer (RED) lead to the positive and the shorter (BLACK) lead to the negative.

2. Connect the batteries as shown in the figure illustrating the required arrangement.

Note.1. When connecting direct to the battery terminals the positive (RED) lead must be connected to the battery positive terminal and the negative (BLACK) lead to the negative terminal as shown in figs.24, 25 and 26, which also show the correct location of the positive terminal on 12 Volt and 6 Volt batteries.

Note 2. When connecting two 6 Volt batteries for float charging as shown in fig.26 it is possible to connect the two wireless set battery plugs incorrectly, so that the charging generator is short circuited. To check this, turn the pedals, slowly at first, and increase the speed until the lamp lights. If it lights in a succession of bright flashes accompanied by jerky movements of the pedals, change over the two wireless set battery plugs to the opposite batteries.

3. Turn the generator pedals at 60 r.p.m. at which speed the charging current is approximately 3.5 Amps. the charging indicator lamp, which is lit by the charging current, should light, fluctuating with the movement of the pedals. The indicator lamp begins to glow when the charging current is approximately 2 Amps.

If the indicator lamp does not light, check the battery connection by verifying that whilst pedalling fast, with the battery disconnected, a sudden braking action is felt when the battery connection is re-made.

Should the battery connection be found in order, replace the indicator lamp with the spare.

DISMANTLING

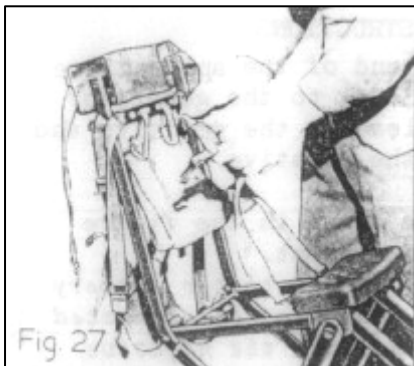

Fig. 27
TURN THE BACK REST OVER
AND UNHOOK SEAT STRAPS



Fig. 28
UNHOOK AND CLOSE THE SEAT
FRAME

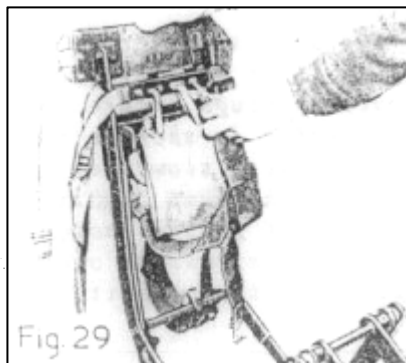

Fig. 29
HOOK THE SEAT STRAPS OVER
SACHELS SIGNALS NO. 7.

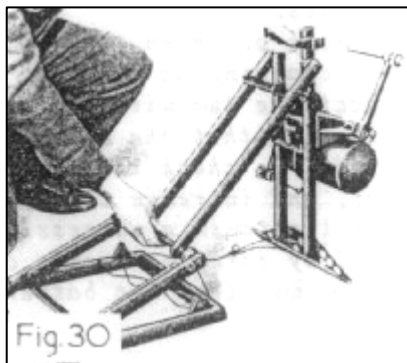

Fig. 30

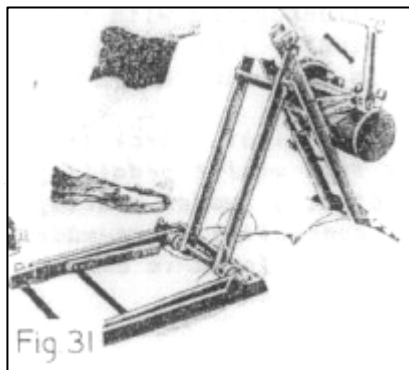

Fig. 31

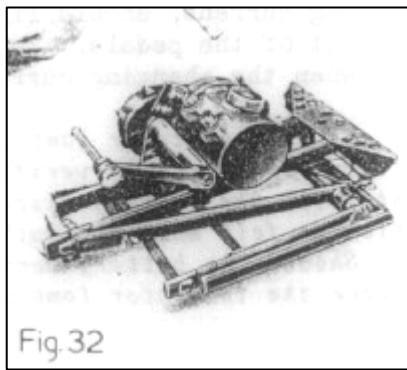

Fig. 32

SEPARATE THE FRAMES AND FOLD THE GENERATOR FRAME AS IN
FIGS. 30-32.

DISMANTLING

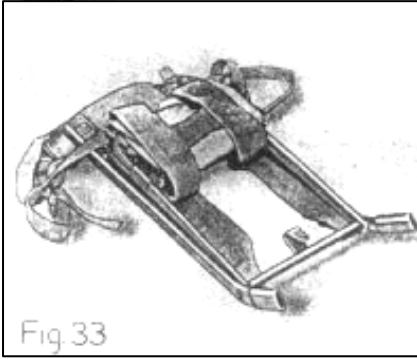

Fig 33

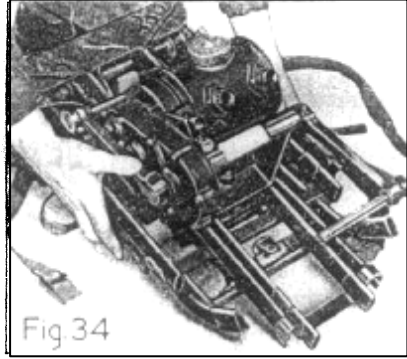

Fig 34

PLACE THE SEAT FRAME ON
THE GROUND

HOOK THE GENERATOR FRAME
ON TO THE SEAT FRAME

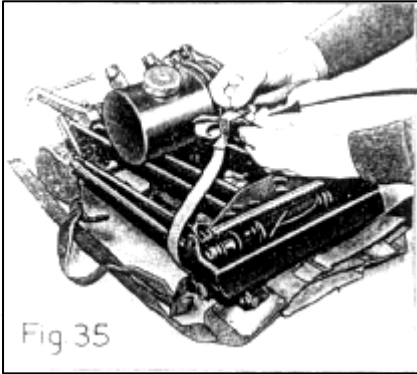
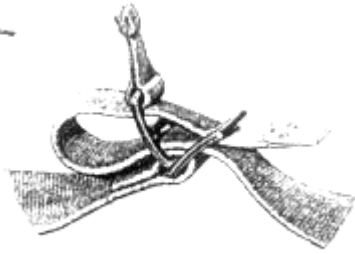

Fig 35



FASTEN THE SECURING STRAP

RESTRICTED

MAINTENANCE.

1. Tighten all nuts and bolts.
2. Keep the apparatus, especially the terminals and plugs and sockets of all connectors, clean.
3. Examine leads for wear. Ensure that the positive lead can be clearly identified.
4. Report when the dessicator indicator is PINK in colour.

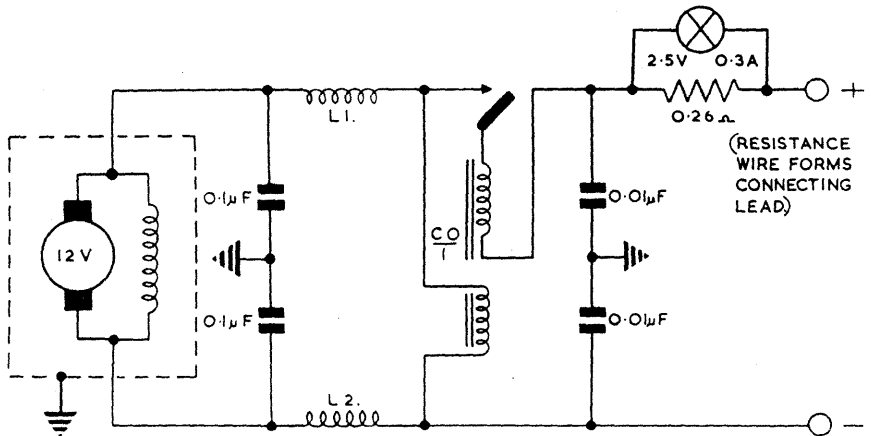

CIRCUIT DIAGRAM

RESTRICTED

The Information given in this document is not to be communicated, either directly or indirectly, to the press or to any person not authorized to receive it.