

# The VMARS Archive

VMARS is a not-for-profit organisation specialising in all types of vintage communications electronics. We maintain an archive of documentation to help our members understand, research, repair and enjoy their vintage radio equipment. Access by non-members is extended as a gesture of goodwill, but not as a right.

Rare documents are frequently provided free of charge by VMARS members, and all scanning and document processing is carried out on a voluntary basis. Accordingly, we do not expect others to profit from the hard work of volunteers, who give their time freely without charge.

**This is a gentle reminder that the document attached to this notice is provided to you for your personal use only. This edition remains copyright of VMARS, and while you may sell or give your copy to someone else, this right does not extend to making further copies of this information, either to give or sell to others. This includes a prohibition on placing it on websites, or printing it for sale at rallies, boot fairs or similar public events. If our goodwill is abused, then withdrawal of public access to our archive will be the result.**

Please refer anyone else wanting a copy back to VMARS – either to our website at <http://www.vmars.org.uk/> or by email to the Archivist at [archivist@vmarsmanuals.co.uk](mailto:archivist@vmarsmanuals.co.uk). If you want to know more about our copyright, please see the FAQ below.

## FAQ on copyright of VMARS documents

- Q** How can you copyright a document that is already in the public domain?
- A.** *Plainly the original copyright of the content has expired, or we have obtained permission to copy them. What we copyright is our own edition of the document.*
- Q.** Surely your “own edition” is identical to the original document, so cannot be copyrighted?
- A.** *Our editions are **not** identical to the original document. You will find that full advantage has been taken of electronic publishing facilities, so pages are cleaned up where possible (rendering them better than originals in some cases!), and large diagrams are prepared for both on-screen viewing and for easy printing at A4 format.*
- Q.** Why do you not just give your manuals away, as so many do via the internet these days?
- A.** *We do make all our manuals available free of charge (in soft copy) to VMARS members. These members have already covered the costs of running the archive via their subscriptions. The only time members are charged for copies is when they request them on paper, in which case charges are restricted to the cost of paper, ink and postage.*

*The VMARS archive is not a “shoe-string” operation. Money is spent on computing facilities to make copies available, and on shipping original documents securely (usually costing several pounds per shipment) to carry out the scanning. As members have already contributed to these costs, it is only reasonable that non-members should do likewise – and thus a very moderate charge is levied for copies provided to non-members. With typical commercial photocopying charges starting at 5 pence per A4 side, it will be evident that paying 4 pence for our equivalent on paper is excellent value (amounts current at Spring 2004). We also think “you get what you pay for” – we invite you to make the comparison and draw your own conclusions!*

*Despite the above, we will be making copies of essential technical information (circuit diagram, parts list, layout) freely available to all via our website from late 2004 onwards. This will be done to try and encourage and enable the maintenance of our remaining stock of vintage electronic equipment.*

## ***Guidance on using this electronic document***

### **Acrobat Reader version**

You need to view this document with Acrobat Reader **version 5.0** or later. It is possible that the document might open with an earlier version of the Acrobat Reader (thus allowing you to get this far!), but is also likely that some pages will not be shown correctly. You can upgrade your Acrobat Reader by direct download from the internet at <http://www.adobe.com/products/acrobat/readermain.html> or going to <http://www.adobe.com/> and navigating from there.

### **Printing the document on A4 paper**

You should note first that virtually all original documents are in double-sided format, i.e. printed on both sides of the paper. Accordingly, our copies are similarly double-sided., and the best results are obtained if the document is printed double-sided. You can print out on one side only, but you will find that you get a number of blank sheets (which can just be removed and reused), and where margins vary in width between left-hand and right-hand pages, there is a danger of the text disappearing into the binding of your printed copy.

This document is of fairly simple format in that it can be made to print out using an A4 format printer (this is the common paper size available in UK and Europe, which measures 29.7cm by 21.0cm). By "simple" I mean that there are no large diagrams on fold out sheets, which will require multiple A4 pages to print out at full size.

Original document sizes do vary a lot – from the small manuals, which approximate to A5 size (21.0 x 14.8 cm) up to the now obsolete foolscap size (21.6 x 33.0 cm). US documents tend to use their "letter" size paper (21.6 x 27.9 cm). All these sizes can be printed on A4 paper by simply getting Acrobat to shrink or enlarge the pages as necessary. This is done as follows:

1. Select "File – Print" or click on the printer icon. This will bring up the print dialog box.
2. Select the correct printer if necessary.
3. Select the pages you want to print – even if you want to print all of the document, you will probably not want to print this notice and help page, so start the printing at page 3.
4. In the "Page Handling" area, next to "Page Scaling", select "Fit to paper". The press "OK"

### **Printing the document on an US Letter format printer**

Since A4 and US Letter sizes are similar, it is expected that this document should print satisfactorily on the latter format paper. This has not been tested however, and is not guaranteed. Follow the steps as for A4 printing, and make doubly sure that "Fit to paper" is selected (step 4).

### **Any other problems?**

Please get in touch with me at [archivist@vmarsmanuals.co.uk](mailto:archivist@vmarsmanuals.co.uk).

Richard Hankins, VMARS Archivist, Summer 2004

RECEPTION SET R 106TECHNICAL HANDBOOK - MODIFICATION INSTRUCTION

Note: This EMER has been redesignated from Tels CY 707/1 (U.K.) and it supersedes Issue 1, dated 8 Oct 45.

SUMMARY

1. Damage is caused in transit to the 50-100kc/s band type J coil set, due to the poor type fixing of these coils. This instruction covers the strengthening of the coil assemblies.

Time required to perform modification: 2 man-hours.

2. Item affected:

50-100kc/s band type J coil set.

3. Action required by R.E.M.E. personnel concerned at the request of the unit holding the equipment. Priority 'B'.

4. Stores required:

<u>Description</u>	<u>No. off per equipment</u>
0.375 in. Keramot or ebonite rod	1 in.
No. 16 S.W.G. Copper wire, tinned	8 in.

Stores will be obtained locally under authority T/W/ZU/4.

DETAIL

5. Select the 50-100kc/s band type J coil set of all Reception sets R 106 and, looking at the front panel of this coil set (trimmers uppermost), remove the 1st., 2nd. and 3rd. coil assemblies, starting at the left-hand coil. If these three coil assemblies are mounted as shown in Fig. 1, they will be modified as follows:-

(a) If turning facilities are not available:-

- (i) Cut and shape three pieces of 16 S.W.G. tinned copper wire as shown in Fig. 3(a) and (b).
- (ii) Fit and solder this shaped wire as shown in Fig. 2.

(b) If the turning facilities are available:-

- (i) Turn and drill three Keramot or ebonite plugs as shown in Fig. 4.
- (ii) Insert the plugs in the open end of coil former, cut and shape a piece of 16 S.W.G. copper wire and fit and solder as shown in Fig. 4.

For all accounting purposes the number of this modification is T/W/ZU/4.

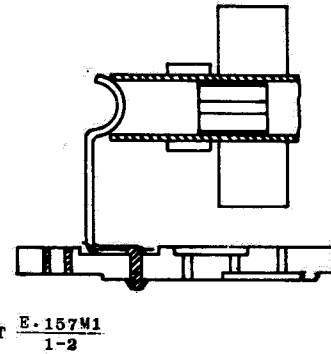
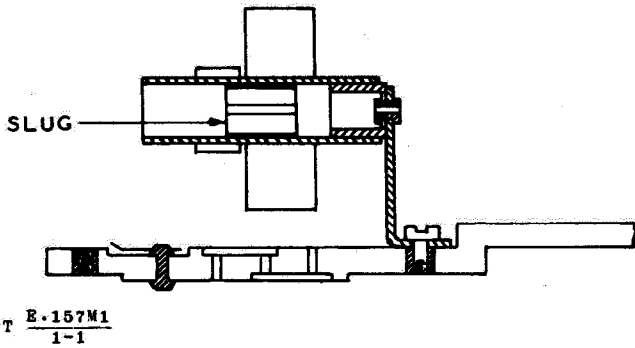

Fig. 1 - Original mounting of 1st., 2nd. and 3rd. coil assemblies

Fig. 2 - Fitting of shaped wire

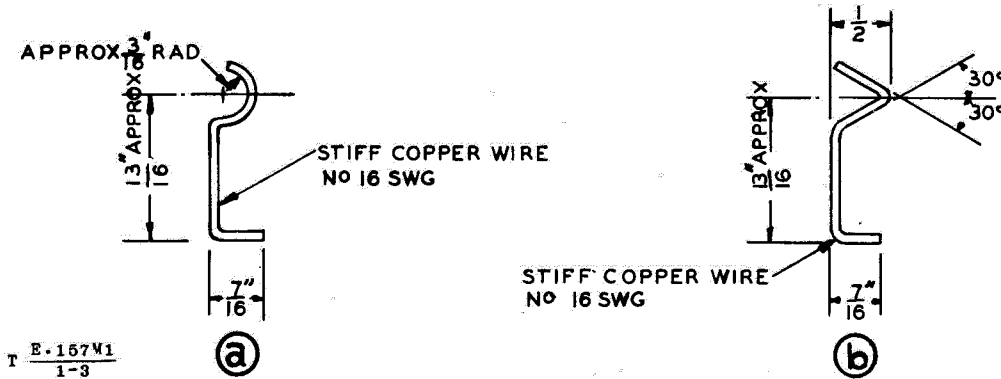

Fig. 3 - Methods of shaping wire

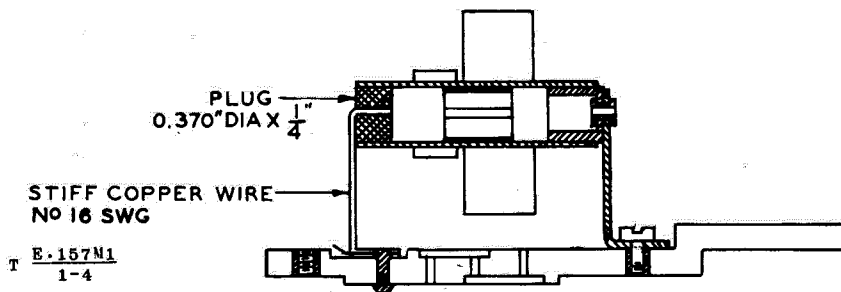

Fig. 4 - Details of plugs

END