

The information given in this document is not to be communicated, either directly or indirectly, to the Press or to any person not authorized to receive it.

CONDITIONS OF RELEASE

(Applicable to copies supplied with Ministry of Defence approval to Commonwealth and Foreign Governments)

1. This document contains classified UK information.
2. This information is disclosed only for official use by the recipient Government and (if so agreed by HM Government) such of its contractors, under seal of secrecy, as may be engaged on a defence project. Disclosure or release to any other Government, national of another country, any unauthorized person, the Press, or in any other way would be a breach of the conditions under which the document is issued.
3. This information is to be safeguarded under rules designed to give the same standard of security as those maintained by HM Government in the UK.

STATION, RADIO, A14

TECHNICAL HANDBOOK - TECHNICAL DESCRIPTION

CONTENTS

	<u>Para</u>
INTRODUCTION	
Role and purpose of equipment ... ..	1
Main parameters ... ..	3
Testing and repair facilities ... ..	11
TRANSMITTER-RECEIVER A14	
BRIEF TECHNICAL DESCRIPTION	
Principals of operation ... ..	15
Receive ... ..	16
Calibrate ... ..	25
Transmit low power ... ..	26
Transmit high power ... ..	39
Construction ... ..	42
Panel and chassis assembly ... ..	43
Amplifier radio frequency ... ..	44
Controls ... ..	45
Metering ... ..	46
Crystals ... ..	49
DETAILED TECHNICAL DESCRIPTION	

CONTENTS (contd)

	<u>Para</u>
Common circuits	
Common crystal oscillator and buffer amplifier	54
Common free tune oscillator	55
Audio amplifier	58
500kHz oscillator	65
Limiter and discriminator	71
Send/Receive relay RLA	77
Transmitter circuits	80
Transmitter <b>mixer</b>	82
Wideband amplifier	85
Driver	87
Power amplifier	89
Modulator and pre-amplifier with a.m.c.	91
Receiver circuits	
R.F. amplifier	104
Receiver mixer and 500kHz filter	107
I.F. amplifier	110
A.G.C. detector and amplifier	114
Limiter and discriminator	118
A.M. detector and noise limiter	119
Amplifier r.f.	123
Band switching	135
Tuner radio frequency	136

CONTROL RADIO SET REMOTE

BRIEF TECHNICAL DESCRIPTION

General	142
---------	-----

DETAILED TECHNICAL DESCRIPTION

Receive	147
Transmit	149
Intercommunication	157
From remote to local	159
From local to remote	161
Sidetone	162

HAND GENERATOR

BRIEF TECHNICAL DESCRIPTION

	165
--	-----

D.C. BATTERY CHARGER 12/24V

BRIEF TECHNICAL DESCRIPTION

	174
--	-----

Fig

LIST OF FIGURES

	<u>Page</u>
1 Receive, simplified block diagram	4
2 Simplified block diagram; transmit low power	6
3 Simplified block diagram; transmit high power	7
4 Panel and chassis assembly	8
5 Amplifier r.f.	9
6 Front panel controls	11
7 Control radio set, remote	22

LIST OF FIGURES (contd)

<u>Fig</u>		<u>Page</u>
8	Interconnecting box ... ..	22
9	Interconnection of the TRA14 and the remote control units ...	23
10	Hand generator, general view ... ..	26
11	D.C. battery charger, general view ... ..	28

LIST OF TABLES

<u>Table</u>		<u>Page</u>
1	Front panel controls ... ..	10
2	Meter M1 ... ..	12
3	Meter M2 ... ..	13
4	RLA functions ... ..	16
5	Tuner r.f. band switch positions ... ..	21

INTRODUCTION

Role and purpose of equipment

1. The SRA14 is a fully transistorised lightweight manpack h.f. radio set.
2. It is primarily intended for use in net communications by airborne and amphibious forces where circumstances preclude the use of v.h.f. equipment.

Main parameters

3. The station operates in the frequency band 2-8MHz either on one of 18 spot crystal frequencies, or by free tuning.
4. There is a choice of amplitude modulation, phase modulation or c.w. operation.
5. The equipment comprises two main units, a basic low power transmitter/receiver and an r.f. amplifier, housed in individual compartments of the same case. The maximum transmitter power output which occurs in p.m. and c.w. is 2 watts on low power and 22 watts on high power.
6. A tuner, radio frequency is provided which allows the station to be used with one of the following antennae:-
  - a. 8 ft rod.
  - b. 27 ft end fed wire.

In addition a dipole antenna system and a 1/4 wavelength end fed antenna are provided. These connect direct to the r.f. amplifier output socket.

7. Power for the station is supplied by four 12V rechargeable nickel cadmium batteries housed in a compartment in the set case.
8. These batteries can be charged by either:-

- a. A hand generator, supplied with the station.
- b. A transistorised battery charger which can be operated from a 12V or 24V d.c. source.

The batteries can be charged in situ by either method or after removal by the latter.

- 9. A morse key, telephone handset and headset are supplied with the station.
- 10. Provision is made for remote operation from a distance up to 1/4 mile.

Testing and repair facilities

- 11. Unit repairs are to be confined to the exchange of CES items.
- 12. Field repairs are normally confined to the fault diagnosis and replacement of faulty modules in the transmitter/receiver. The tuner radio frequency, amplifier r.f. and remote control units are to be repaired by component replacement.
- 13. The specification testing and fault diagnosis to a module can be carried out using the normal range of test equipment held in field workshops and the test kit radio SRA14. Details of this test kit are given in EMER Tels M 330.
- 14. Workshops which are designated to carry out repairs to modules will be provided with special test units to allow these modules to be repaired and tested.

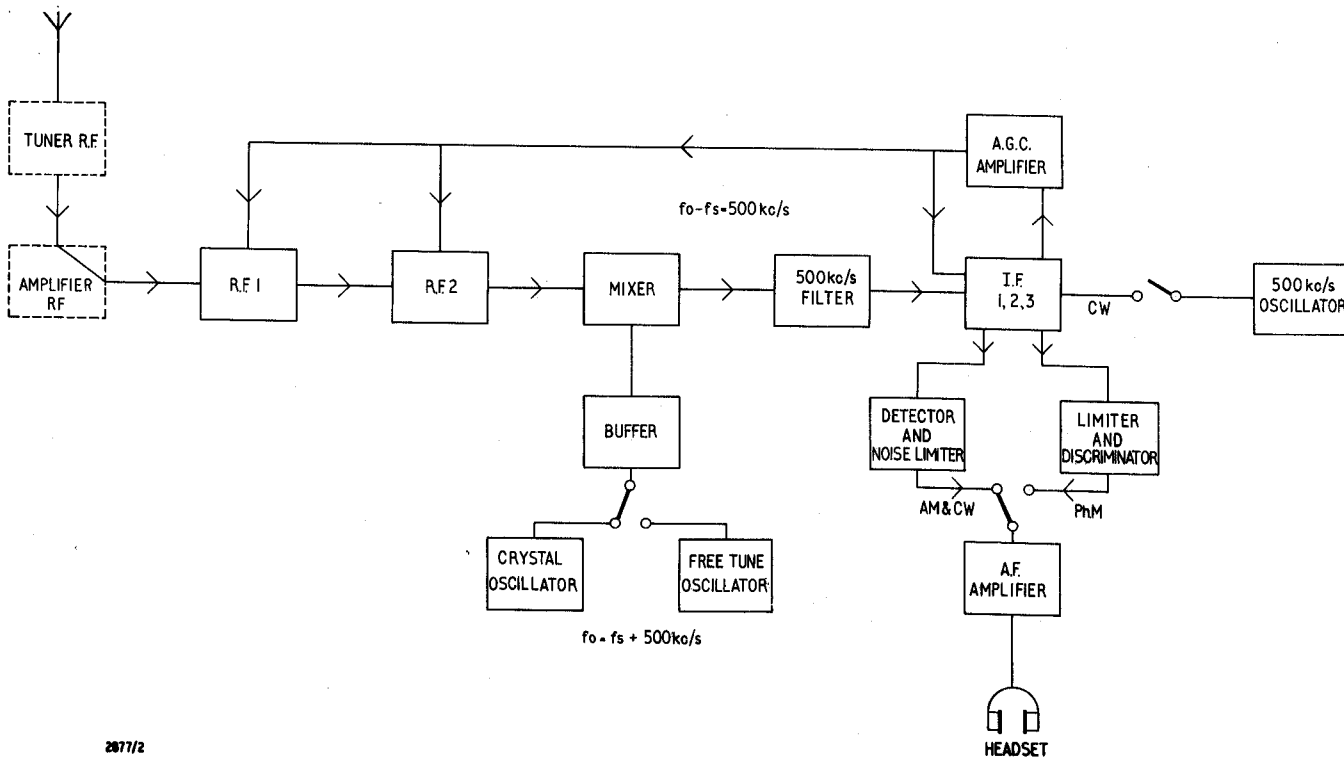

Fig 1 - Receive, simplified block diagram

TRANSMITTER-RECEIVER A14

BRIEF TECHNICAL DESCRIPTION

Principles of operation

15. The block diagrams illustrate the stages in use on the main modes of operation. The complete TRA14 block diagram is given in EMER Tels F 162 Pt 2 Fig 2501.

Receive  
(Fig 1)

16. The received signal is coupled via the tuner r.f. (bypassing the amplifier r.f.) to the first of two tuned r.f. stages. The output from the second r.f. stage is fed into the receiver mixer.

17. There is a choice of two local oscillators, the first, which is crystal controlled, gives a selection of 18 spot frequencies, and the second allows free tuning over the band 2-8MHz. The local oscillator always operates 500kHz above the signal frequency.

18. The signal and local oscillator frequencies are fed to the mixer. The 500kHz bandpass filter in the output circuit selects the required 500kHz difference frequency.

19. This filter determines the selectivity of the receiver making the overall bandwidth  $\pm 3$ kHz minimum at -6dB and  $\pm 10$ kHz maximum at -65dB.

20. There are three transformer coupled i.f. amplifiers whose final output is fed to a detector and noise limiter, a limiter and discriminator, and delayed a.g.c. detector and amplifier.

21. The rectified a.g.c. amplifier output is applied to both r.f. amplifiers and to the first two i.f. amplifiers.

22. On a.m. the detector output is fed via a noise limiter to the audio amplifier.

23. On c.w. the output of a 500kHz oscillator acting as a b.f.o., is fed into the last i.f. stage, and the a.f. beat-note produced in the detector is passed via the noise limiter to the audio amplifier.

24. On p.m. the i.f. output is fed via a limiter to a conventional Foster-Seeley discriminator, and thence to the audio amplifier.

Calibrate

25. With the system switch set to TRF, both the crystal oscillator and free tune oscillator are brought into operation. The tuning dial is set to the signal frequency corresponding to the selected crystal frequency, ie crystal frequency minus 500kHz, and the resultant beat note is fed via the buffer amplifier to the audio stage. The tuning control is varied until zero beat is obtained. This enables the tuning dial to be checked against one of the 18 crystal frequencies.

Transmit low power  
(Fig 2)

26. The output of either the crystal oscillator or the free tune oscillator, as selected, is fed via the buffer to the mixer where it is mixed with the output of the 500kHz oscillator.

27. The output of the 500kHz oscillator is kept stable by an a.f.c. loop utilising the receiver discriminator and the phase modulator reactor.
28. The difference frequency of the two oscillators is selected by the tuned circuit in the mixer output and fed to a single stage wideband amplifier.
29. The output of the wideband amplifier passes to a single stage tuned driver which in turn feeds the p.a. stage.
30. The power amplifier consists of a matched pair of transistors connected in parallel and operating in class C.
31. The tuned tank circuit is connected in the collector circuit of the p.a. transistors.
32. The output from the tank circuit is coupled to the tuner r.f., if in use, via the HP/LP switch in the amplifier r.f.
33. On a.m. operation the output from the microphone amplifier is fed to the push-pull modulator. The gain of the microphone amplifier is controlled by a feed-back loop.

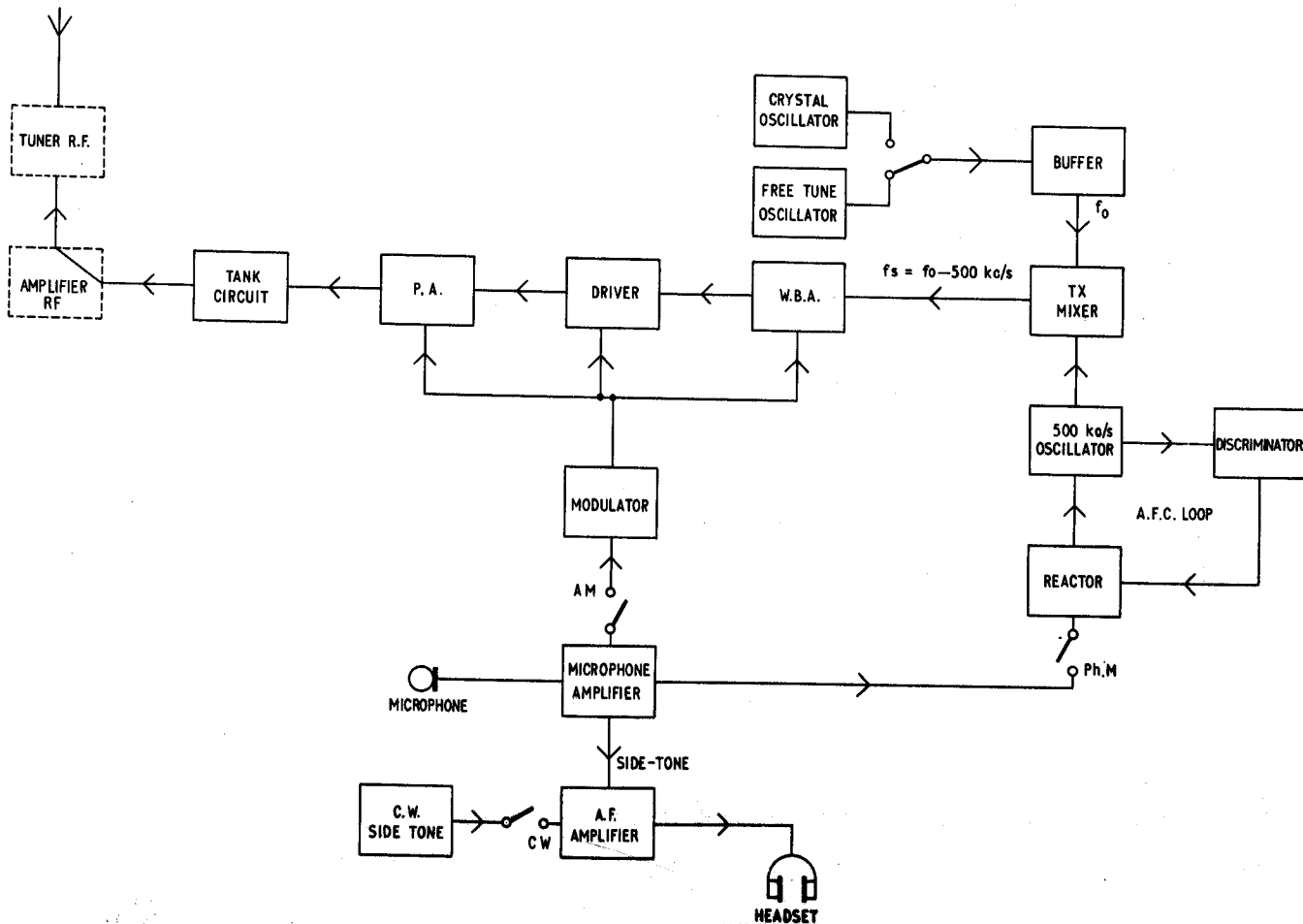
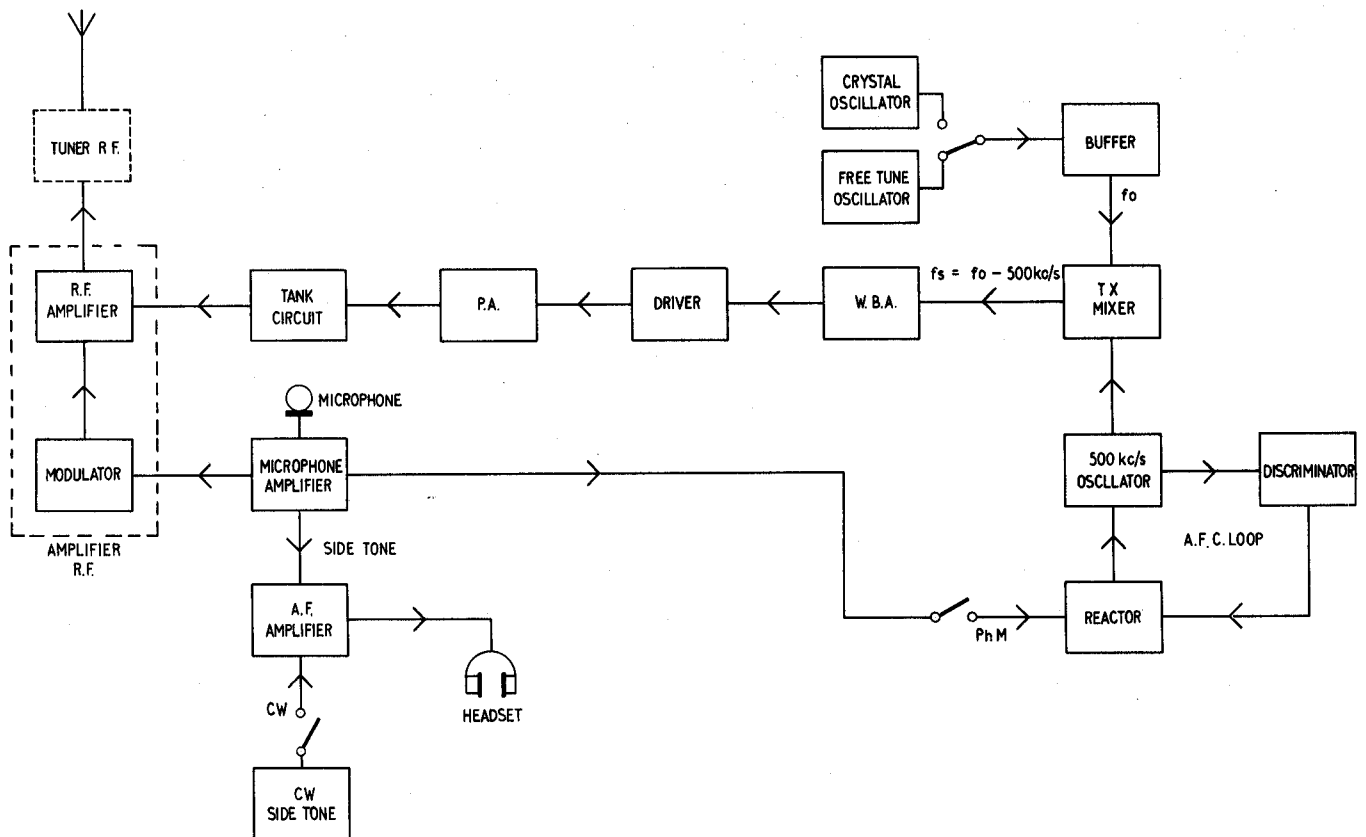

Fig 2 - Simplifier block diagram; transmit low power

34. The output of the modulator is impressed on the common 12V supply to the wideband amplifier, the PA driver and the PA stage.
35. On p.m. operation the output from the microphone amplifier is applied to a reactor circuit which controls the frequency of the 500kHz oscillator. The deviation is limited to a maximum of 1.5 radians.
36. Simulated sidetone is provided on both amplitude and phase modulation by feeding part of the microphone amplifier output direct to the audio amplifier stage.
37. On c.w., keying is carried out by switching the 12V supply to most of the transmitter stages by means of the send/receive relay.
38. A sidetone oscillator is switched into circuit on c.w. and the keyed output of the oscillator is fed into the operator's headset via the audio amplifier.

Transmit High Power  
(Fig 3)

39. On h.p. the output from the p.a. tank circuit is fed to a single stage power amplifier instead of direct to the tuner r.f. or antenna.



2877/5

Fig 3 - Simplified block diagram; transmit high power

40. On a.m. the output from the microphone amplifier is fed to a push-pull modulator, in the Amplifier r.f. unit, which is then used to modulate the p.a. of the amplifier r.f.

41. On p.m. the method of modulation is unchanged from that used in the low power mode.

#### Construction

42. The transmitter-receiver A14 consists of two main units (the amplifier radio frequency and the panel and chassis assembly) housed in a single diecast alloy case. The whole is fully sealed and conforms to DEF 133 L3 and can be used in any part of the world.

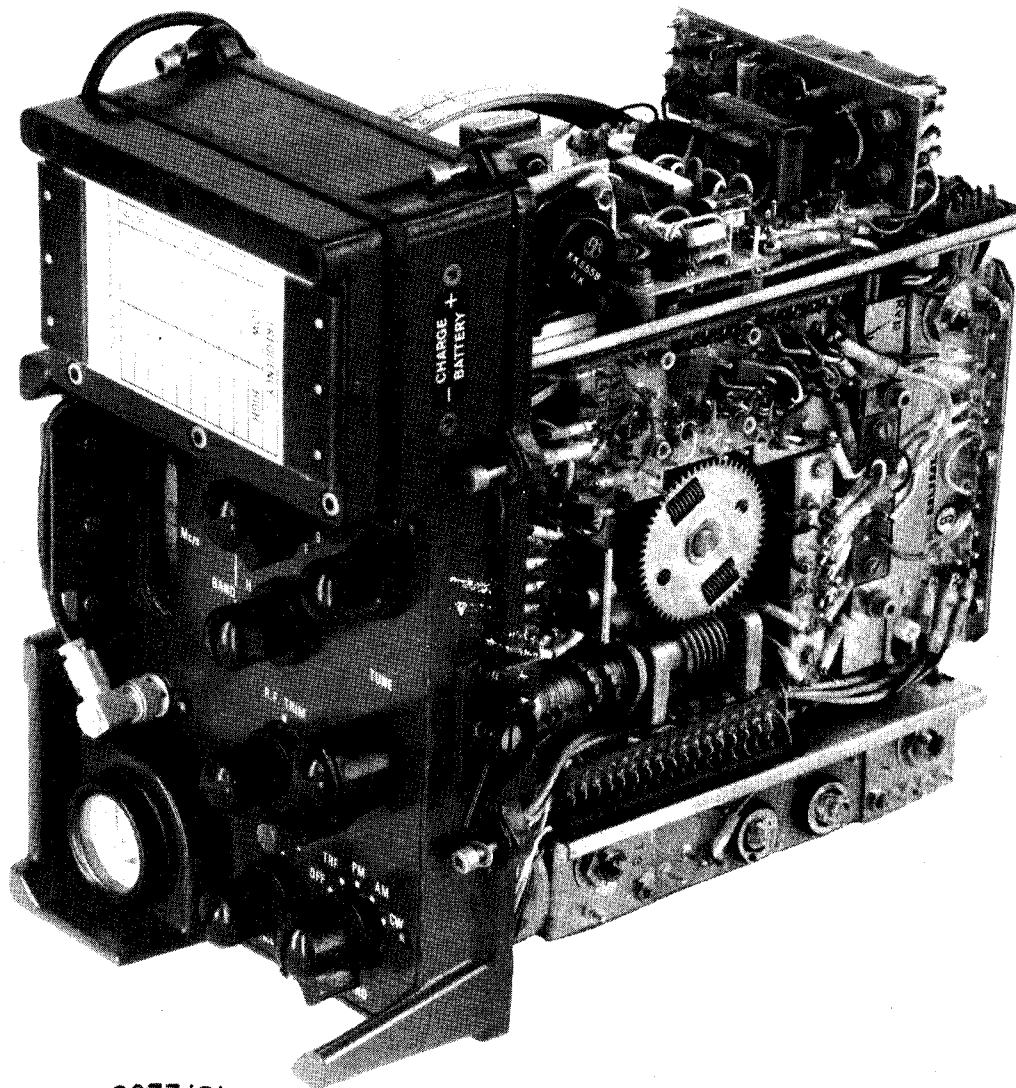

2877/21

Fig 4 - Panel and chassis assembly



Panel and chassis assembly  
(Fig 4)

43. This is the basic transmitter-receiver section of the TRA14 and is a self contained transmitter and receiver with the exception of power supplies. It consists of a number of removable sub-assemblies attached to a central frame which is secured to the rear of the light alloy casting forming the front panel. The complete assembly is retained by socket headed screws and is sealed in the case by means of a gasket.

Amplifier radio frequency  
(Fig 5)

44. This is of conventional construction and replacement of components is facilitated by removal of screws which enables the unit to be extended to the limits of the cable-forms; this provides access to all components in the amplifier.

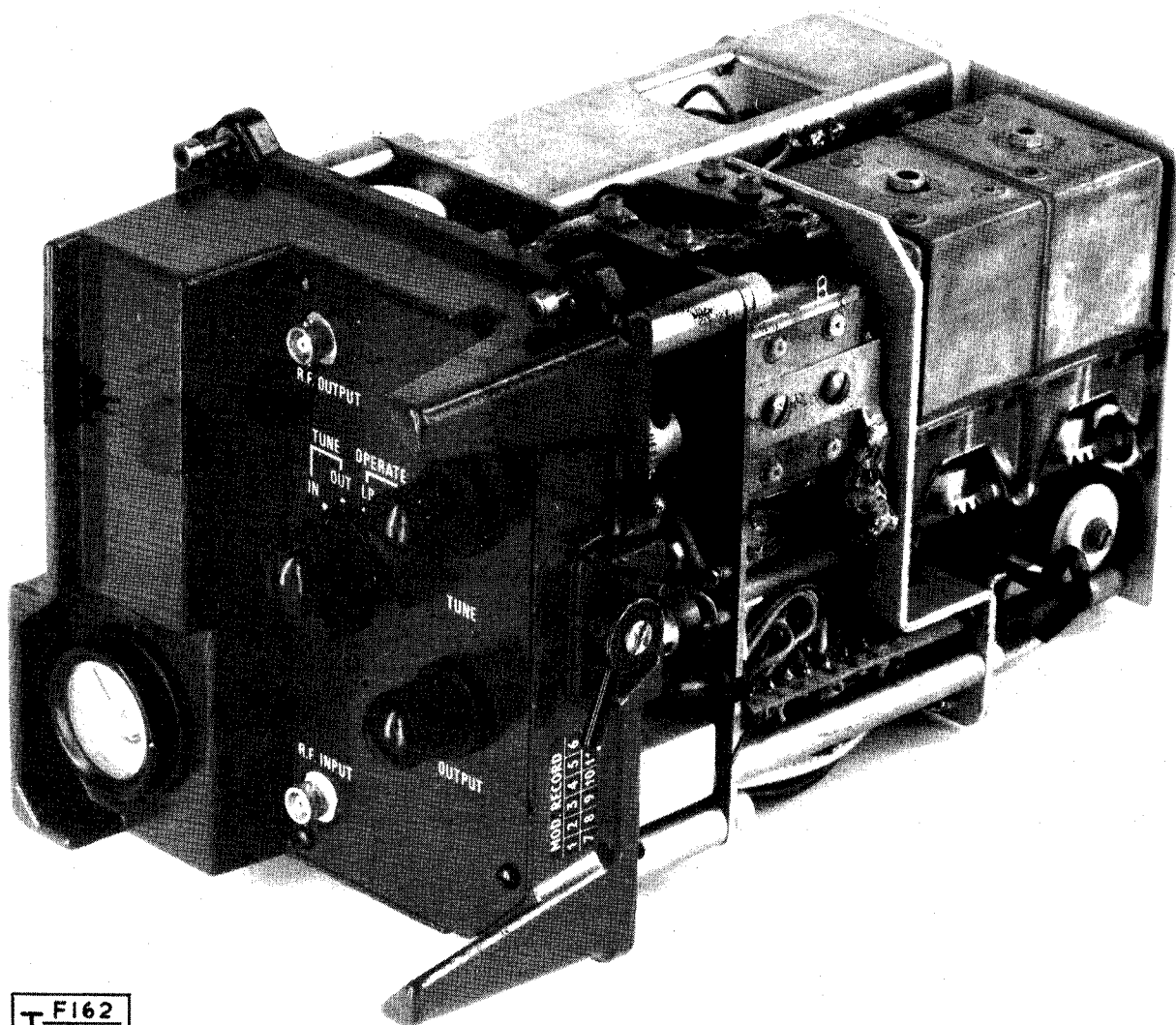

T F162  
1-2 2877/22

Fig 5 - Amplifier r.f.

Controls  
 (Fig 6)

45. The front panel controls are shown in Fig 6 and details are given in Table 1.

Table 1 - Front panel controls

Item	Function
System switch SB	<p>TRF - Used when aligning the transmitter and receiver tuned circuits to the selected crystal frequency.</p> <p>PM - Used when tuning the Tuner r.f. for correct indication on meter M1 in preparation for operation on PM, AM or CW. Also used when voice communication is required with phase modulation of the transmitter carrier. In this position the discriminator is connected to the receiver a.f. amplifier and the output from the microphone amplifier is applied to the reactor in the transmitter circuit.</p> <p>AM - Used when voice communication is required with amplitude modulation of the carrier. In this position the a.m. detector is connected in the receiver circuit and the output from the microphone amplifier is fed to the modulator in the transmitter circuit.</p> <p>CW - Used for c.w. operation and netting. Also gives an indication of battery voltage on the meter M1.</p>
CW TONE	This is the b.f.o. control for use on c.w. When netting to a control station on free tune the pointer of this control should be set to the white spot.
RF TRIM	This is used for final tuning of the p.a. tank circuit, when initially setting up the transmitter.
TUNE	This is a slow motion drive controlling the ganged capacitor in the transmitter and receiver tuned circuits.
Tune Control Lock	This locks the TUNE control firmly in position when tuning is completed.
GAIN	This control sets the receiver audio output level.
BAND	This control selects either the low (L) (2-4MHz) or high (H) (4-8MHz) section of the frequency band covered by the set.
CHANNEL	This switch selects the required crystal frequency (1-9), on either the low or high band, or free tuning (F). At (T) both oscillators are switched off. This facility is only used during internal alignment.

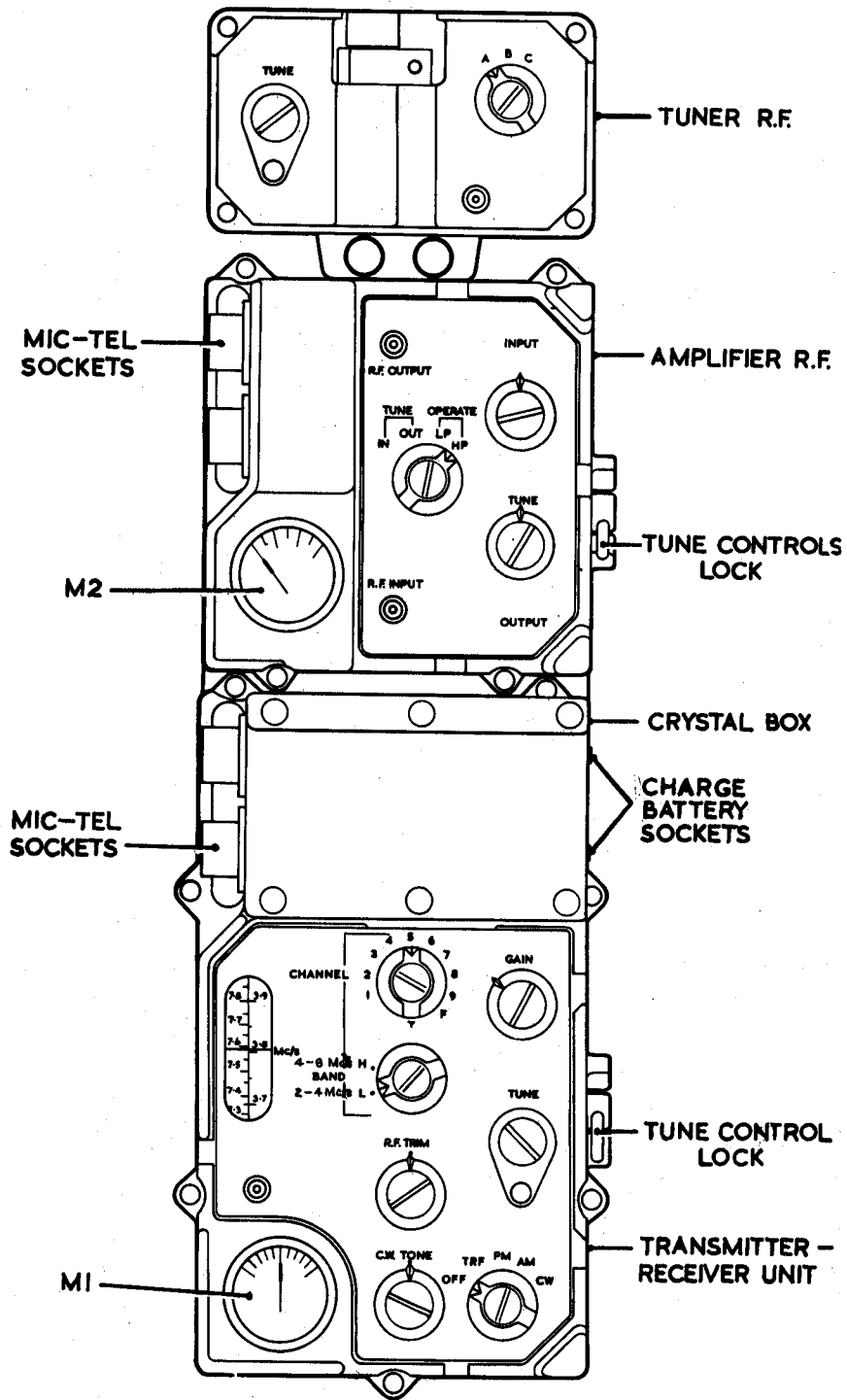

2677/36

Fig 6 - Front panel controls

Table 1 - (cont)

Item	Function
Amplifier r.f. system switch SWB	TUNE-IN - this terminates the amplifier with a $76\Omega$ load and connects the meter M2 across the input circuit.
	TUNE-OUT - terminates the amplifier with a $76\Omega$ load and connects the meter M2 across the output circuit.
	OPERATE-LP - connects the input from the panel and chassis assembly direct to the RF OUTPUT socket.
	OPERATE-HP - connects the input from the panel and chassis assembly to the amplifier input and the amplifier output to the RF OUTPUT socket.
INPUT	Tunes the input circuit of the amplifier r.f. to the incoming signal from the basic transmitter.
OUTPUT	Tunes the output circuit of the amplifier r.f. to the outgoing signal and matches the output circuit of the amplifier to the tuner r.f. or the antenna.

Metering

46. A small 100-0-100 microammeter, M1, fitted to the front panel of the panel and chassis assembly gives tuning indication and shows the state of the batteries. Built in beta light fluorescence enables the meter to be seen in the dark.

47. A second (0-300) microammeter, M2, is fitted to the amplifier r.f. to provide tuning indications for the amplifier circuits.

48. The functions of the two meters in each position of the system switches are given in Tables 2 and 3.

Table 2 - Meter M1

System switch position	Meter function
OFF	Meter is out of circuit and the needle remains at centre zero.
TRF	The meter shows a positive deflection, ie to the right of centre zero, when the tuned circuits are exactly aligned during the tuning procedure.
PM	The meter is biased to the left so that it reads slightly more than $-100\mu\text{A}$ . This allows the full scale deflection of the meter to be used to register antenna current when the tuner r.f. is being tuned. The PM position must always be used for tuning the transmitter irrespective of the method of transmission finally selected.

Table 2 - (cont)

System switch position	Meter function
AM	The meter is biased as in the FM position to indicate antenna current while transmitting on AM.
CW	The meter reads battery voltage, a green sector on the scale indicates the range of voltages acceptable for operating the set.

Table 3 - Meter M2

System switch position	Meter function
TUNE - IN	The meter indicates the amplitude of the r.f. input from the panel and chassis assembly.
TUNE - OUT	The meter indicates the (reduced) r.f. output of the amplifier r.f. to the dummy load.
OPERATE - LP	The meter is not in circuit.
OPERATE - HP	The meter indicates transmitter high power output to the antenna.

Crystals

49. Eighteen crystal controlled channels are available, nine on the low band and nine on the high band. The set is designed so that each channel is common to both transmitter and receiver. On receive the signal frequency is subtracted from the crystal oscillator frequency to give the 500kHz intermediate frequency, whilst on transmit a frequency stabilised 500kHz oscillator is mixed with the crystal oscillator to give the required signal frequency.

50. Style K crystals are used for the high band and style D crystals for the low band. They are fitted into sockets in the crystal compartment located at the top of the front panel.

51. The crystal sockets are made accessible by removing the screws securing the compartment cover, the channel numbering is shown inside the cover.

52. The crystal frequency required may be found from the following formula:-

$$\text{crystal frequency} = \text{signal frequency} + 500\text{kHz}$$

DETAILED TECHNICAL DESCRIPTION  
(Fig 2502 and 2503)

Common circuits

54. The circuits which serve both the transmitter and the receiver are the common oscillators, crystal or free tune, the audio amplifier, the 500kHz oscillator, the limiter and discriminator, and the send/receive relay RIA.

Common crystal oscillator and buffer amplifier

55. These circuits are both on the same module being part of module K.

56. A single transistor VT28 is connected as an emitter coupled Colpitts type oscillator. The oscillator output is developed across the emitter load resistor R127 and fed via an impedance masking resistor R120 to the base of the buffer amplifier, VT16.

57. The buffer amplifier is a conventional emitter follower circuit, the output of which is switched either to the receiver or to the transmitter mixer circuits.

Common free tune oscillator

58. This circuit forms part of module L.

59. When free tuning is required the supply voltage to the crystal oscillator is switched off and that of the common free tune oscillator is switched on. The same buffer amplifier is utilised.

60. The oscillator is a two stage feed back oscillator, a tapping on the tuned circuit C88 and L10 (or L11) being connected across the base of VT18 and earth. Part of the output developed across R67 is fed back to the base of VT18 to maintain oscillations. C88 is part of the main tuning gang capacitor.

61. In order to check the calibration of the free tune oscillator, it is arranged that with the system switch at TRF both the crystal and free tune oscillators are switched on. The crystal frequency corresponding to the channel frequency at which the calibration check is to be made is selected by the channel switch and the free tune oscillator is then tuned to this channel frequency. Both oscillations will then be at channel frequency plus 500kHz.

62. The outputs of the two oscillators mix in the buffer amplifier VT16 and the beat note produced is fed to the audio stage.

63. Tuning is continued until zero beat is obtained and a maximum reading is given on meter M1.

64. The calibration error, if any, can then be obtained by checking the actual reading of the tuning dial with the desired frequency, ie actual crystal frequency minus 500kHz.

Audio amplifier

65. This circuit forms part of module C.

66. The audio amplifier is a conventional two stage resistor capacitor coupled amplifier with the audio output transformer in the collector of VT21. Overall negative feedback is obtained from the secondary of the a.f. transformer and is fed back to the base of VT20 via R125.
67. On receive, the output from either the detector or the discriminator (as selected by the system switch) is fed via the gain control RV6 and C98 to the base of the first stage VT20. This stage receives its power supplies via the send/receive relay on receive, and is disconnected on send.
68. On c.w. transmit, the output from the sidetone oscillator VT19 is fed via C94 to the base of VT21, the second stage of the amplifier, to provide a keying tone in the headset.
69. On a.m. and p.m. transmit, part of the output of the microphone amplifier is coupled to the base of VT21 as sidetone.
70. At the TRF position of the system switch the audio difference frequency produced in VT16 by the beating of the crystal and free-tune oscillators is coupled to the base of VT21, via R61 and C115 and enables the free-tune oscillator to be tuned to zero-beat with the crystal oscillator.

500kHz oscillator

71. This circuit forms part of module G.
72. The oscillator is of the Hartley type, the tuned circuit being the primary of T21 in parallel with C124 and the two variable capacitor diodes ZD8 and ZD9.
73. When used as a b.f.o. on receive the bias on the variable capacitor diodes and in turn their effective capacity, is varied by a d.c. potential obtained via R111 from the c.w. tone control RV8. This varies the frequency of oscillation. With the control set at the centre zero position for netting purposes, a nominal oscillator frequency of 500kHz is obtained. The output is taken from a tapping of T21 and fed to the base of VT6 (i.f.3) via a C41/C159.
74. On transmit this same output is coupled via C50 to the base of VT8, the a.f.c. amplifier, and thence to the discriminator. The d.c. output of the discriminator is applied to the junction of ZD8 and ZD9 (RLA-2 operated) to maintain the oscillator frequency at 500kHz. This nominal 500kHz is mixed with the crystal frequency to produce the required signal frequency.
75. On phase modulation the microphone amplifier output at the collector of VT12 is taken via a pre-emphasis network and RV11 to the variable capacity diodes ZD8 and ZD9 and used to frequency modulate the 500kHz oscillator.
76. This modulated 500kHz frequency is added to that of the common oscillator (crystal or free-tune) in the transmitter mixer (para 83) and produces a phase modulation of the sum frequencies.

Limiter and discriminator

77. This circuit forms part of module D.

78. On receive, an output from the last i.f. stage (i.f.3), is fed via C145 to the base of VT9. A limiting network C53, MR2 and MR3 in conjunction with amplifier VT9 ensures that the a.m. content of the signal is removed.

79. The collector load of VT9 is a conventional Foster-Seeley discriminator. In the FM position of the system switch the output is fed via a de-emphasis circuit and the audio gain-control RV6 to the a.f. amplifier.

Send/Receive relay RIA

80. This relay is mounted on module K.

81. RIA is a four section changeover relay which is energised on transmit. The functions of the contacts are given in Table 4. Brackets in column 1 contain grid references on Fig 2503.

Table 4 - RIA functions

Relay section	Receive function	Transmit function
RIA/1 (V5)	Connects the 12V supply to the receiver r.f. and i.f. stages, the b.f.o. variable bias-control circuit and the first stage of the audio amplifier.	Connects the 12V supply to the transmitter r.f. stages, the a.f.c. amplifier, the microphone amplifier, the 500kHz oscillator, the discriminator, the c.w. side-tone oscillator and the modulator as selected by the system switch.
RIA/2 (Q4)	Connects the b.f.o. variable bias-control circuit to the reactor diodes ZD8 and ZD9 of the 500kHz oscillator.	Connects the discriminator d.c. output plus a standing bias to the reactor diodes for a.f.c. operation.
RIA/3 (P7)	Connects the input circuit of the transmitter mixer to earth.	Connects the input circuit of the transmitter mixer to the output of the common oscillator.
RIA/4 (A2)	Connects the antenna socket SKTA to the receiver r.f. amplifier.	Connects the antenna socket to the p.a. tank circuit and the antenna metering circuit.

### Transmitter circuits

#### Transmitter mixer

82. This circuit forms part of module M.

83. The output from the 500kHz oscillator is transformer coupled to the bases of VT25 and VT26 which are arranged in push-pull for balanced mixing. The output from the common oscillator is fed to the centre tap of the transformer. The difference frequency component is selected by either T19 or T20, tuned by C116, which is part of the main gang capacitor.



84. On the low frequency band the output from the mixer is transformer coupled to wideband amplifier via an additional winding of T19. On the high band, however, the output is capacity coupled from the tuned secondary of T20 via C117. When not in use the low band secondary tuned winding of T19 is shorted to earth.

Wideband amplifier

85. This circuit forms part of module C.

86. The wideband amplifier VT24 is a conventional untuned transistor amplifier. The collector load transformer T18 is shunted by a 1k $\Omega$  resistor R97 to ensure a flat response over the required frequency range. The supply voltage comes via the modulator circuit.

Driver

87. This circuit forms part of module M.

88. The output from the wideband amplifier is transformer coupled to the base of VT23 the p.a. driver. The amplified output is transformer coupled to the bases of the p.a. transistors on both high and low bands, via either T16 or T17, tuned by C108, which is part of the main tuning capacitor.

Power amplifier

89. This circuit forms module B.

90. The Class C power amplifier stage consists of a matched pair of transistors, VT29 and VT30, connected in parallel. It has a tuned transformer as the common collector load. An additional winding is coupled to the antenna socket. Tuning is by C64, a section of the main tuning capacitor.

Modulator and pre-amplifier with a.m.c.

91. This circuit forms part of module C.

92. The input from the microphone is fed via the preset level control RV4, and C74 to the base of the pre-amplifier transistor VT14.

93. The collector output of VT14 is transformer coupled to the push-pull amplifiers VT12 and VT13. A portion of this output is also fed via the preset level control RV9, and C115, to the audio amplifier as sidetone.

94. In order to obtain a degree of automatic modulation control, a portion of VT13 collector output is rectified by MR8 and fed back to the base of VT15.

95. The collector of VT15 is connected to the emitter of VT14 via the capacitor C75 which acts as the emitter decoupler of VT14.

96. With MR8 non-conducting, VT15 is fully conducting and C75 is virtually earthed thus providing optimum decoupling of VT14 emitter. VT14 operates at full gain.

97. As the modulation signal increases a portion is applied via the a.m.c. preset level control RV5 to the rectifier MR8 and a negative voltage proportional to the audio signal is fed as bias to the base of VT15.
98. This negative voltage reduces the emitter/collector current and so reduces the decoupling effect of C75, this in turn causes the gain of VT14 to fall. Hence the level of modulation is maintained constant.
99. The output of VT12 and VT13 is transformer coupled by T12 to the power transistors VT10 and VT11 in the modulator.
100. The modulator is in operation only on low power a.m. because only in this position the system switch SB/F in the amplifier r.f. (Fig 2504) completes the modulator collector circuit to earth from the centre tap of T11.
101. The 12V supply to the wideband amplifier, the driver, and the power amplifiers is fed via the secondary of T11 in the power modulator output. The modulation is thus impressed on the supply line, providing collector modulation of these stages.
102. On high power a.m. operation, unmodulated drive is required for the amplifier r.f., this is obtained by switching off the low power modulator.
103. The audio output of the modulation pre-amplifier is taken from the collector of VT12 and fed to the modulator in the amplifier r.f. when on high power a.m. operation.

### Receiver circuits

#### R.F. amplifier

104. This circuit forms part of module M.
105. The input signal from the antenna socket of the panel and chassis assembly is connected via the send/receive relay and a tuned circuit to the base of VT1, the first r.f. amplifier. The collector load of VT1 is a tuned circuit whose output is transformer coupled to the base of VT2, the second r.f. amplifier.
106. The second r.f. amplifier is untuned and its output is transformer coupled to the receiver mixer. Automatic gain control (a.g.c.) is applied to both amplifier stages. The diodes MR16 and MR18 are provided for overload protection against an excessively strong input signal.

#### Receiver mixer and 500kHz filter

107. This circuit forms module F.
108. The output of the second r.f. amplifier is transformer coupled by T22 to the base of the receiver mixer, VT3, and the output from the common oscillator is also applied to the base of VT3 via the secondary of T22, additive mixing takes place and the difference frequency (500kHz) is selected by the filter.
109. The filter is a six section band-pass type centred about 500kHz. This improves the selectivity of the receiver and gives an overall bandwidth of 6kHz at 6dB down. The output of the filter is transformer coupled to the first intermediate amplifier, VT4.

I.F. amplifier

110. This circuit forms part of module J.

111. There are three i.f. amplifier stages VT4, VT5 and VT6. A.G.C. is applied to the first two stages VT4 and VT5. The 500kHz output from the i.f. filter is coupled to the base of the first i.f. amplifier VT4, the collector load of which is a tuned circuit.

112. The output of VT4 is transformer coupled to the base of VT5. This second i.f. amplifier is untuned, the collector load consisting of an r.f. transformer shunted by a resistor. The output of VT5 is transformer coupled to the third i.f. amplifier VT6.

113. This stage has a tuned circuit in the collector which has three outputs:-

- a. Transformer coupled output to the a.g.c. detector.
- b. Transformer coupled output to the limiter and discriminator.
- c. Direct from the collector to the a.m. detector.

A.G.C. detector and amplifier

114. This circuit forms part of module J.

115. One of the output from the final i.f. amplifier (VT6) is transformer coupled to the rectifier MR1. This rectifier has a standing delay bias, its RV2 value depending on the position of the preset RV2. When the i.f. output exceeds this bias the rectifier will conduct, and the current through R28 will increase. This will result in a drop in the base-emitter voltage and a resultant drop in the collector current and voltage of VT7.

116. This variation in collector voltage, which varies according to the mean signal level, is fed to the a.g.c. line where it is applied to the bases of both r.f. amplifiers and the first two i.f. amplifiers.

117. RV1 in the emitter circuit of VT7 controls the a.g.c. characteristics. This is set so that for an 80dB variation in signal level the output of the receiver changes by only 10dB. The electrolytic capacitor C48 in the base of the transistor ensures that the correct time constant is maintained.

Limiter and discriminator

118. The second output from the third i.f. amplifier feeds the limiter and discriminator circuit. This is described in previous paragraphs under common circuits.

A.M. detector and noise limiter

119. This circuit forms part of module G.

120. The third output from the last i.f. amplifier feeds the detector and noise limiter. The signals applied to MR9 are demodulated and the resultant a.f. developed across the detector load R75 and R76, is fed via MR10 (the noise limiter) C96 and the system switch to RV6 and thence to the a.f. amplifier.

121. The purpose of the noise limiter is to temporarily isolate the detector from the a.f. amplifier for the duration of large interference pulses.
122. During reception the d.c. component of the detector output is developed across C93 making the anode of MR10 more positive than its cathode. This forward biases the diode causing it to pass the a.f. signal through R75 and C96 to the a.f. amplifier. When a large noise pulse occurs the long time constant of C95/R77 tends to hold the potential at MR10 anode unchanged but its cathode rises by the increased voltage across R75, R76 cutting off MR10. C95 provides a virtual short circuit for a.f. from R77/R78 junction to earth and thus, during short noise bursts, the a.f. output is cut off.

Amplifier r.f.  
(Fig 2504)

123. This unit is designed to amplify the transmit output of the panel and chassis assembly on OPERATE - HP only. The amplifier has a gain of approximately 10dB. On OPERATE - LP the equipment low power facility is available and the amplifier is switched out of circuit.
124. A high power silicon transistor, VT1, connected in a common base configuration, is employed as a single stage amplifier. Between 1 and 2 watts of drive is applied to the r.f. input socket, through the RLC relay contacts on transmit, to the primary of the input transformer T1. The secondary of this transformer together with L1 or L2 and C1 and C2 form a series tuned circuit to match the incoming drive to the input impedance of VT1. C2 is the TUNE INPUT control.
125. The collector of VT1 contains a tuned 'pi' matching network comprising R4, L6, C9, C10, C11 and C14. C10 and C11 are ganged to form the TUNE OUTPUT control. This enables the collector impedance to be matched to the 75Ω output impedance.
126. The two TUNE controls are adjusted for maximum meter deflection during the setting up procedure. With the system switch at either of the TUNE positions a 76Ω resistor R7 is connected across the amplifier output to absorb the r.f. power.
127. On transmit, with the system switch at OPERATE LP the amplifier is out of circuit and the r.f. input socket is connected direct to the r.f. output socket via the relay RLC.
128. On transmit, with the system switch at OPERATE HP the r.f. input socket is connected to the input of the amplifier stage VT1, and the output of the amplifier is connected to the r.f. output socket via the relay RLC and the system switch.
129. In the receive mode of either OPERATE position, the r.f. input socket is connected direct to the r.f. output socket via the relay RLC.
130. On a.m. transmit, at OPERATE HP, the a.f. from the microphone is taken via the pre-amplifier in the panel and chassis assembly to the modulator circuit in the amplifier r.f. This a.f. is fed to VT6 which drives a push-pull modulator VT2, VT3, VT4 and VT5 arranged in compound pairs with a dual secondary transformer T2 as the load.
131. One secondary winding is connected in VT1 collector supply line to give conventional modulation, and the other winding applies additional modulation to the base of VT1 via L4.

132. On p.m. transmit high power, modulation takes place as normal as in the low power mode and the phase modulated signal is fed to the amplifier r.f. for normal amplification.
133. On p.m. and c.w. the collector voltage of VT1 is a nominal 36V but on a.m. is only 24V, the connection of the appropriate supply being selected by R1A for p.m. and c.w. and R1A and R1B for a.m. On a.m. the supply for the modulator and driver is the same as that for VT1. (see Figs 2512 and 2513).
134. On c.w. transmit high power, the supply to VT1 is maintained constant due to the fact that relay R1A is slugged by capacitors C17 - C20.

Band switching

135. The ledex switch SA in the amplifier r.f. is electrically connected to the band switch in the panel and chassis assembly. When the band switch is operated it mechanically selects the correct coils for the high or low band in the panel and chassis assembly, at the same time the ledex switch in the amplifier r.f. is also energised and selects the appropriate coils in the amplifier.

Tuner radio frequency  
(Figs 2508 and 2509)

136. The tuner r.f. provides optimum matching of either the panel and chassis assembly or the amplifier r.f. output stage to the rod or end fed wire antennae used with this equipment.
137. The tuner is a separate unit housed in its own fully sealed diecast alloy case. It can either be attached to the TRA14 or detached and operated in the remote role, metering is provided in the tuner for this purpose.
138. The unit consists basically of two loading coils L1 and L2, which are connected in series or parallel arrangements depending on the setting of the tuner band switch, and a metering circuit. Tuning is achieved by varying the coupling between these two coils.
139. The tuner band switch is a three position switch whose setting depends on the frequency and type of antennae in use. Table 5 shows this relationship and also shows the interconnections of the loading coils.

Table 5 - Tuner r.f. band switch positions

Type of antenna	Band in use	Switch setting	Arrangement of L1 and L2
Rod or end-fed wire	L and lower part of H	A	L1 and L2 in series
Rod	Upper part of H	B	L1 and L2 in parallel
End-fed wire	Upper part of H	C	L1 in parallel with part of L2

140. Coils L1 and L2 are tuned by an arrangement of 12 ferroxcube rings moulded into an epoxy resin cylinder which surrounds the coil former. A ferroxcube rod is also axially located inside the coil former and is attached to the external ferroxcube cylinder. The whole ferroxcube assembly is driven concentrically along the axis of the coil former by the TUNE control drive mechanism.

141. The meter circuit consists of a bridge rectifier MR1-MR4 fed by a transformer T1. The rectified r.f. is filtered by C2 and R2 and fed to a 0-300 $\mu$ A meter via PLC and PLD. The meter is fitted with shunt circuits and a protective diode. It is illuminated by beta light fluorescence for use in the dark.

CONTROL RADIO SET REMOTE

BRIEF TECHNICAL DESCRIPTION

General

142. The use of (L) or (R) after a component reference indicates that the component is part of the Local (L) or Remote (R) unit.

143. The remote control set allows the TRA14 to be operated from any distance up to 1/4 mile away. The set comprises two units:-

- a. Control radio set, remote control unit 513 L (local) this is shown at Fig 7.
- b. Interconnecting box, remote control unit 513 R (remote) this is shown at Fig 8.

144. Interconnection of the TRA14, the local and remote control units are as shown in Fig 9.

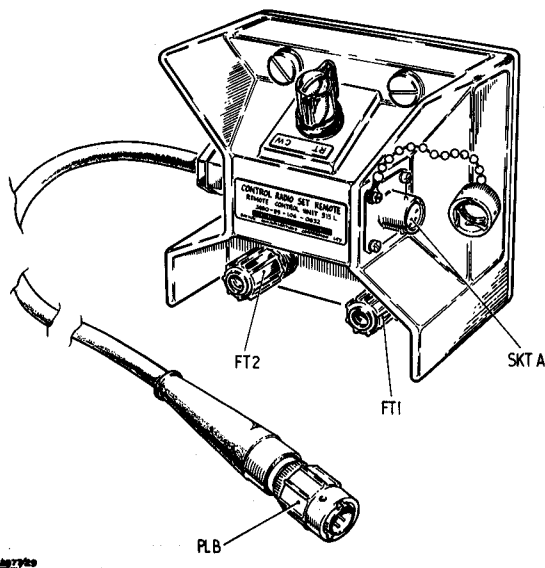

Fig 7 - Control radio set, remote

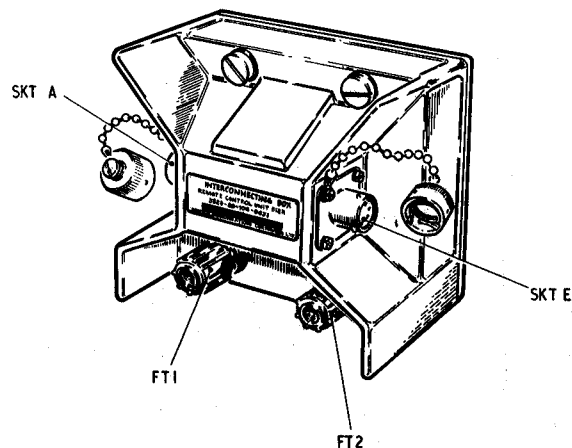
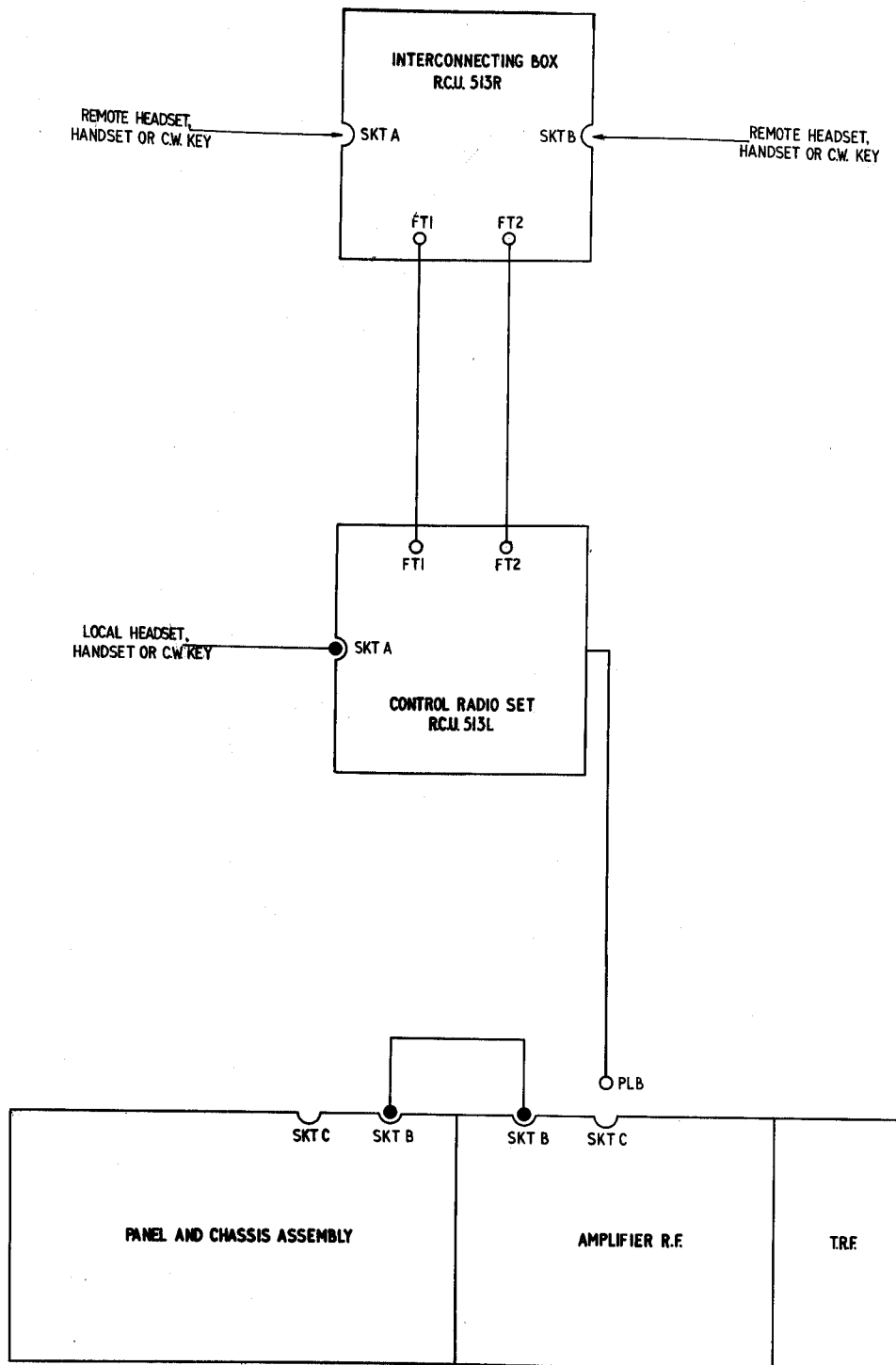

Fig 8 - Interconnecting box

145. Speech communication from the remote operator to the local operator is not possible when the local unit (L) is switched to CW. The local operator can speak to the remote operator on either RT or CW.



287/28

Fig 9 - Interconnection of the TRA14 and the remote control units

146. The local operator's handset socket is connected in parallel with the TRA14 handset sockets and the operator may connect his handset to either the local unit or direct to the TRA14. In both cases, all normal operating facilities are immediately available to the local operator. The remote operator has full operating facilities under the control of the local operator.

### DETAILED TECHNICAL DESCRIPTION

#### Receive

(Fig 2514 and 2515)

147. The a.f. signal from the receiver is fed direct to the local headset through PLB and SKTA of the remote control unit. A portion of this a.f. is amplified by VT2(L) and fed to the line terminals FT1 and FT2. The d.c. circuit (+12V) for VT2(L) is from pin B of SKTA via R10 and R6 to the emitter; the return collector path is via T $\Phi$  primary to pin D of SKTA (earth).

148. The a.f. signal is received by unit R at the terminals FT1 and FT2. It is then fed to the remote handset via C1(R), the a.f. path being completed via C4(R).

#### Transmit

(Figs 2514 and 2515)

149. On transmit, the local operator has normal send facilities on a.m., p.m. and c.w.

150. R.T. and c.w. operation by the remote operator is controlled by the position of the RT/CW switch SA in the local unit L.

151. Before the remote operator closes his pressel switch or operates his morse key, no current is flowing through R2 (L). The base of transistor VT1(L) is therefore at earth potential, VT1(L) is cut off, and relay RLA is not energised.

152. When the remote operator closes his pressel switch or morse key, the +12V d.c. supply circuit to the emitter of VT1(R) is completed via the following path:-

Local unit (L): pin B (PLB), R9, R1 and terminal FT1.

Remote unit (R): terminal FT1, T1 secondary, Pin D (SKTA or SKTB), pin C (SKTA or SKTB) and R4.

VT1(R) collector return path is via T1 primary FT2(R), FT2(L), R2(L) and pin D (PLB - earth).

153. The current flowing through R2(L) causes a positive voltage to be applied to VT1(L) base which makes VT1(L) conduct, the collector current energises relay RLA causing:-

- a. RLA/1 - Contacts 2 and 3 close and operate the send/receive relay in the TRA14.
- b. RLA/2 - Contacts 4 and 5 open to break the a.f. receive circuit from the remote control line when SA is at the RT position.



c. RLA/3 - Contacts 22 and 23 close to complete the microphone input circuit from FT1(L) to pin A (PLB) when SA is at the RT position.

d. RLA/4 - Contacts are not used.

154. With the remote pressel switch closed the microphone output is connected to the base of VT1(R) via C2(R) and R1(R). It is amplified by VT1(R) and passed to the remote line via T1(R) secondary and C4(R).

155. The audio signal is received at FT1(L) is passed via C2(L), R4(L), SA - a (at RT), RLA contacts 22 and 23 (closed on send) and SA - b (at RT) to pin A (PLB), and the return path completed via pin D (PLB), C3(L) and FT2(L).

156. Diodes MR1(R) and MR2(R) in the remote unit R protect VT1(R) against reversed polarity connection. If the connections to FT1 and FT2 are incorrect, +12V d.c. is applied to FT2 and the diodes will conduct providing a safety shunt across the remote control unit R, the current also produces a voltage drop across R2(L) which causes the transistor VT1(L) to conduct and the TR A14 to switch to send.

#### Intercommunication

157. Two way intercommunication is available between the local and remote operators when the TRA14 is set to PM or AM and the local remote control unit (513L) is set to RT.

158. This intercommunication is available with the transmitter on or off. With the transmitter on, the CHANNEL switch of the TRA14 is set as for normal operation; with the transmitter off, the CHANNEL switch is set to position T.

#### From remote to local

159. When the remote operator presses his pressel switch, with the local unit set at RT, RLA(L) and the send/receive relay in the TRA14 is energised as described in paras 154 and 155. The audio signal from the remote unit (R) is passed through the local unit to the microphone input of the TRA14 via pin A of PLB, as described in para 155.

160. This a.f. is fed as normal modulation input to the pre-amplifier, VT14, of the TRA14. A portion of the output of VT14 (sidetone) is fed to the audio amplifier VT21, whose output is transformer coupled to pin F of SKTB and SKTC of the TRA14. This output is directly connected to pin F of SKTA in the local unit (L) and therefore to the earphone of the local operator. Feedback of this a.f. to the remote unit (R) via VT2(L) is prevented by the changeover of relay contact RLA - 2 (L).

#### From local to remote

161. When the local operator closes his pressel switch with the local unit set at RT, the send/receive relay of the TRA14 is energised. The microphone input is fed direct to the TRA14 as normal modulation. The sidetone output is fed back into the local unit (L) as described in para 162. The amplified output of VT2(L) is passed to the remote operator as described in paras 147 and 148. (RLA(L) is not energised).

#### Sidetone

162. False sidetone is provided as normal for the local operator through the TRA14.

163. Speech false sidetone for the remote operator is provided by feeding the output across the secondary of T1(L) through C1(L) back to the earphones. On c.w. the output of the c.w. sidetone oscillator of the TRA14 is fed to local unit (L) and amplified by VT2(L). The output across the secondary of T1(L) is connected to FT1(L) through SA - c and SA - d on c.w. and C1(L). The audio signal at FT1(L) is connected direct to FT1(R) and through C1(R) to the remote earphones.

164. Pin E of SKTA and SKTB in the remote unit (R) and pin E of PLB and SKTA in the local unit (L) are not used and therefore these sockets cannot be used for in-situ charging of the SRA14 batteries.

HAND GENERATOR

BRIEF TECHNICAL DESCRIPTION

(Fig 10 and 2540)

165. The hand generator is used to recharge batteries where conventional charging facilities are not available. It can also be used to power sets operating on low power, when their batteries are connected and completely discharged.

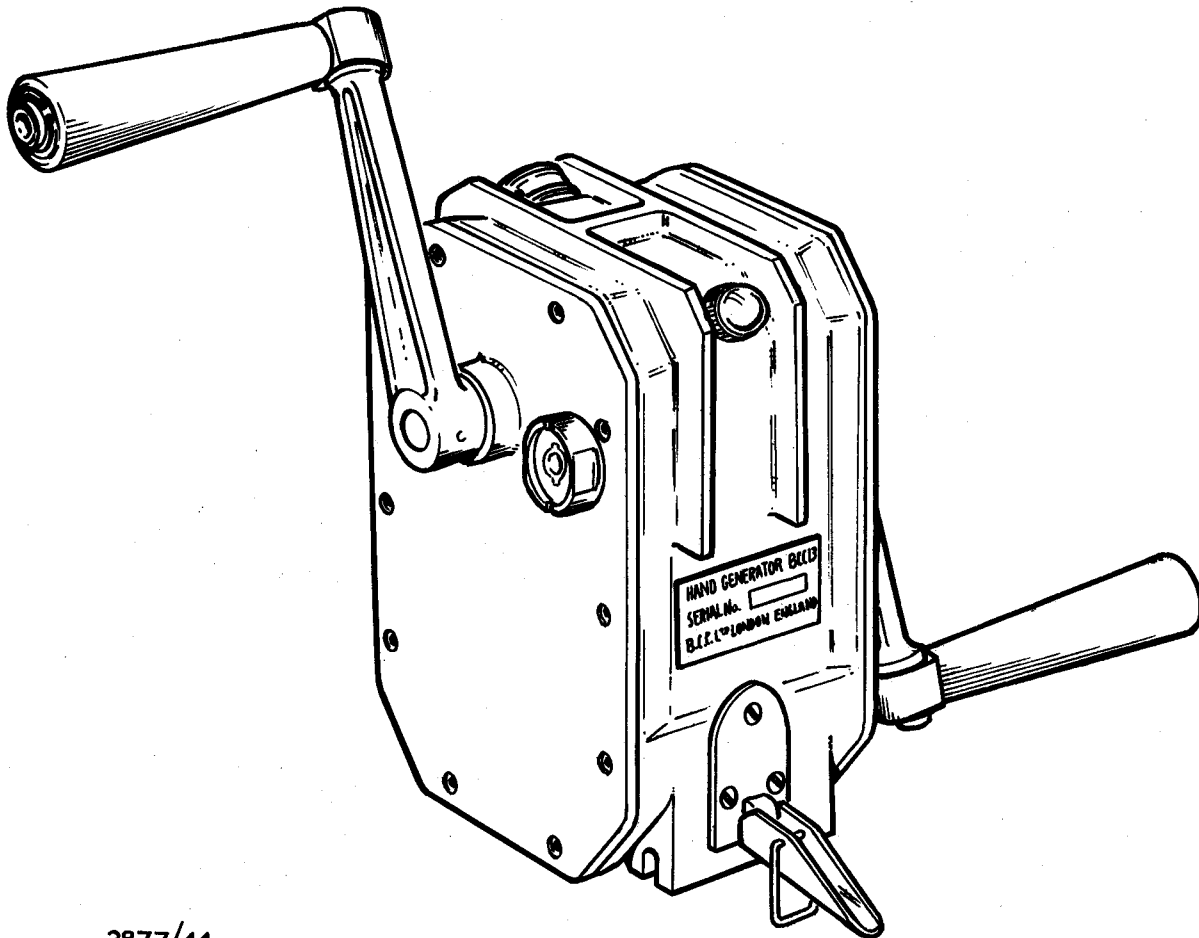

2877/44

Fig 10 - Hand generator, general view

166. The generator is constructed from light alloy castings and is normally mounted on four legs but can be attached to a tree using a special clamp.

167. The generator consists of three main sections:-

- a. Hand drive and gearbox.
- b. Alternator.
- c. Charging control circuit.

168. The gearbox consists of a train of single helical gears having a ratio of 40 : 1. The driving gear is pinned to the drive shaft and, through two intermediate gears, drives the permanent magnet rotor.

169. The alternator is a three-phase unit with a six pole permanent magnet rotor and a stator containing three windings. These are connected to six diode rectifiers, MR1 - MR6, arranged for full-wave rectification. The rectifier output off load is between 17 and 20 volts d.c. On normal load the output is between 13 and 15 volts.

170. The charging control circuit provides an indication of correct cranking speed and also ensures that the output voltage is not grossly exceeded if the cranking speed is increased after the pilot lamp is extinguished.

171. The speed indicator circuit consists of VT1 and VT2 which are controlled by the reference voltage supplies by ZD1, and the setting of RV1. When cranking commences, pilot lamp LP1 lights when the output current is sufficient and remains on until the rectified output reaches 14.2 volts. At this point VT2 is cut off which in turn cuts off VT1 and the light is extinguished. The generator is now operating at the correct speed (60 r.p.m. handle speed).

172. VT3, VT4 and VT5 operate together as a conventional series stabiliser ensuring that the output voltage does not increase proportionally to the cranking speed. RV2 is adjusted so that the rectified d.c. open circuit output is 14.2V  $\pm$ 0.2V when the handle is rotated at the correct speed.

173. VT3, in conjunction with MR7, also isolates the control circuit from the batteries in the set when the hand generator is connected but not in use. R7 limits the initial current into fully discharged batteries to a value which does not overload the rectifiers.

#### D.C. BATTERY CHARGER 12/24V

##### BRIEF TECHNICAL DESCRIPTION

(Fig 11 and 2543)

174. The battery charger enables up to 4 SRA14 batteries to be charged from a 12 or 24 volt d.c. supply.

175. A voltage selector plug on the front panel indicates the voltage input (12 or 24V d.c.) for which the charger has been preset. Alteration for the alternative supply voltage is effected by simply reversing the position of this plug.

176. The charger consists of a transistor d.c./d.c. converter and voltage stabiliser capable of delivering the constant output of 14 volts required.

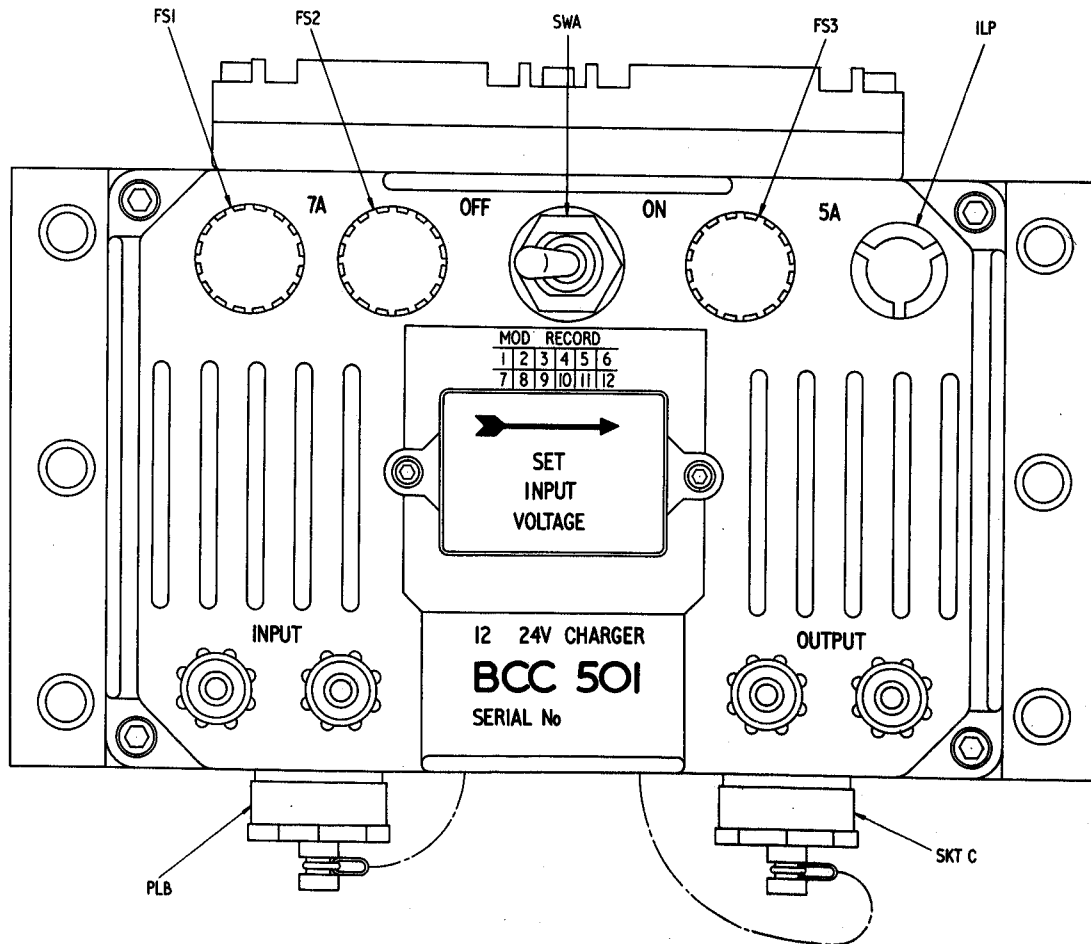

2877/95

Fig 11 - D.C. battery charger, general view

177. The 12 or 24V input is fed in to PLB, if the input polarity is wrong MR1 is forward biased and conducts heavily causing FS1 or FS2 to fuse.

178. VT1 and VT2 form a push-pull saturation-type oscillator. Bifilar windings are used in the oscillator transformer T1 so that they can be connected in series (for 24V) or in parallel (for 12V operation). The series or parallel arrangement is effected by the input voltage selector plug.

179. The oscillator is self starting, using resistive network R2, R3 and R4 to give the required bias. For 12 volt operation R2 is short circuited to maintain the correct bias. Frequency of oscillation is approximately 3kHz.

180. The output from T1 secondary is rectified by bridge rectifier MR2, MR3, MR4, MR5 and smoothed by C9, C10.

181. The stabiliser is a conventional series type, the series variable element being formed by VT4, VT5 and VT6. The output voltage is set by RV1. Any change in output voltage will cause VT7 base potential to vary with respect to its emitter, which is held at a fixed potential by ZD1. If the output voltage increases VT7 base becomes more negative with respect to the emitter and VT7 collector current therefore increases. VT7 collector current flows through R5 and R6 thus VT3 base becomes less negative and its emitter current falls. This in turn causes the base/emitter bias of VT4, VT5, and VT6 to fall, increasing the effective resistance of the series element and reducing the output voltage. If the output voltage falls below the set level the reverse action occurs.

182. MR6 is included in positive output lead to prevent the batteries discharging back through the charger, should the input supply be disconnected. MR7 and FS3 are included to protect the charger should a battery be connected with the wrong polarity.

EME8c/2877/Tels

END

0

0

OD

0